

Compressor Air Brake Systems

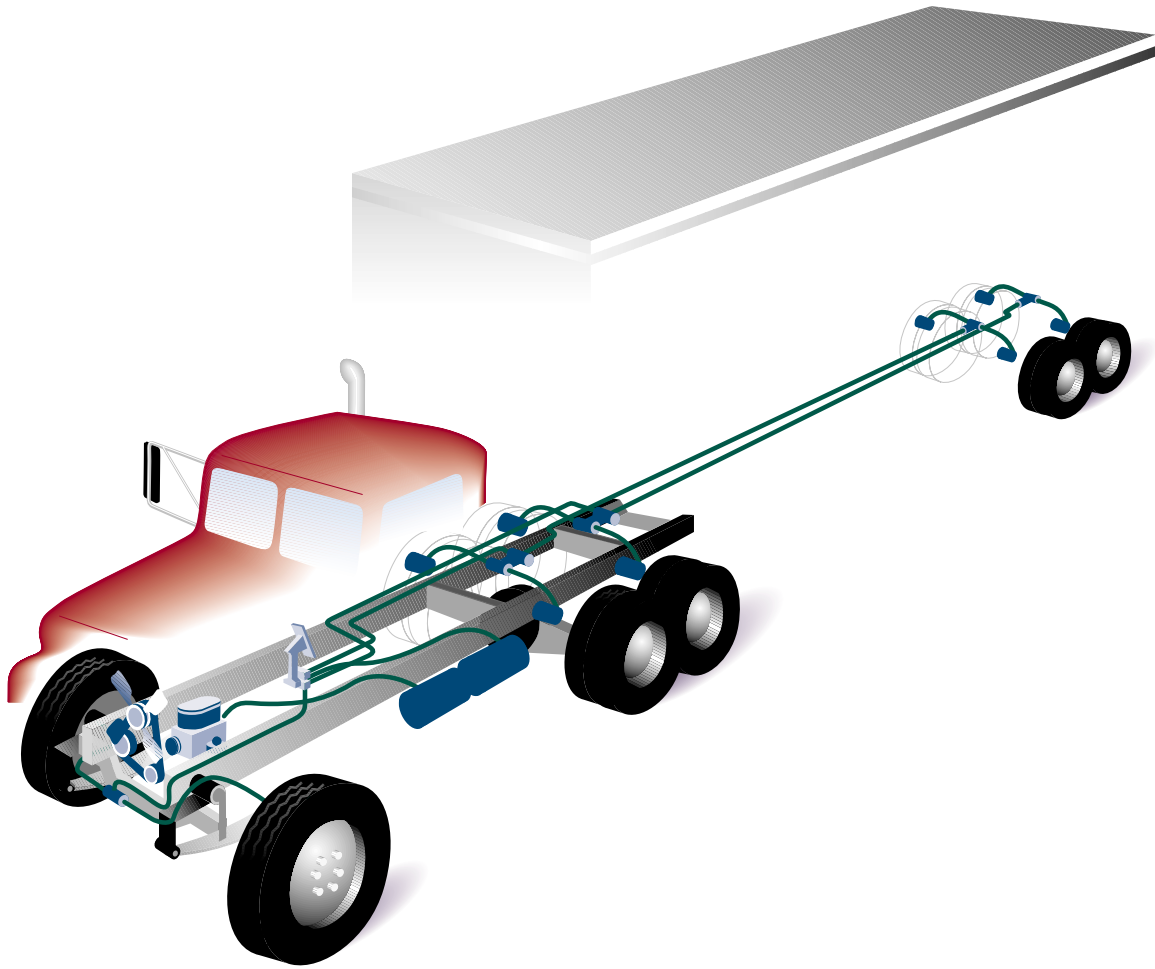

FC350 Engine and Truck Hose

Features:

- AQP® elastomer tube
- Single-wire braid reinforcement
- Multi-purpose construction
- Color-stabilized polyester braid cover
- Screw-together reusable fittings

Benefits:

- Superior temperature range (-55°F to +300°F / -49°C to +150°C)
- Excellent service life performance
- Recommended for a wide range of engine and vehicle applications
- Superior abrasion resistance; enhanced appearance
- Worldwide fitting selection and availability; field detachable and serviceable



Aeroquip FC350

AQP[®] Engine and Truck Hose



Specifications and Performance:

(FMVSS 106 Type All)

Part Number	Hose I.D. (mm/inch)	Hose O.D. (mm/inch)	Max. Oper. Press. (Bar/psi)	Min. Burst Press. (Bar/psi)	Min. Bend Radius (mm/inch)
FC350-04	4.8/.19	13.2/.52	138/2000	552/8000	19.1/.75
FC350-05	6.4/.25	14.7/.58	103/1500	412/6000	25.4/1.00
FC350-06	7.9/.31	17.3/.68	103/1500	412/6000	31.8/1.25
FC350-08	10.4/.41	19.6/.77	86/1250	344/5000	44.5/1.75
FC350-10	12.7/.50	23.9/.94	86/1250	344/5000	57.2/2.25
FC350-12	15.9/.62	27.4/1.08	52/750	208/3000	69.9/2.75
FC350-16	22.2/.88	31.2/1.23	28/400	112/1600	88.9/3.50
FC350-20	28.6/1.12	38.1/1.50	21/300	84/1200	114.3/4.50
FC350-24	34.9/1.38	44.5/1.75	17/250	68/1000	139.7/5.50

Operating Temperature Range:

- -55°F to +300°F
(-49°C to +150°C)
- Except air +250°F (+121°C)

Vacuum Rating (in/Hg):

- 28 (sizes -04 through -10)
- 20 (size -12)
- 15 (sizes -16 and -20)
- 11 (size -24)



Eaton Aeroquip
 Industrial Division
 3000 Strayer Road, P.O. Box 631
 Maumee, Ohio 43537-0631
 419/867-2600, Fax: 419/867-2629
 www.aeroquip.com



Specifications subject to change without notice