

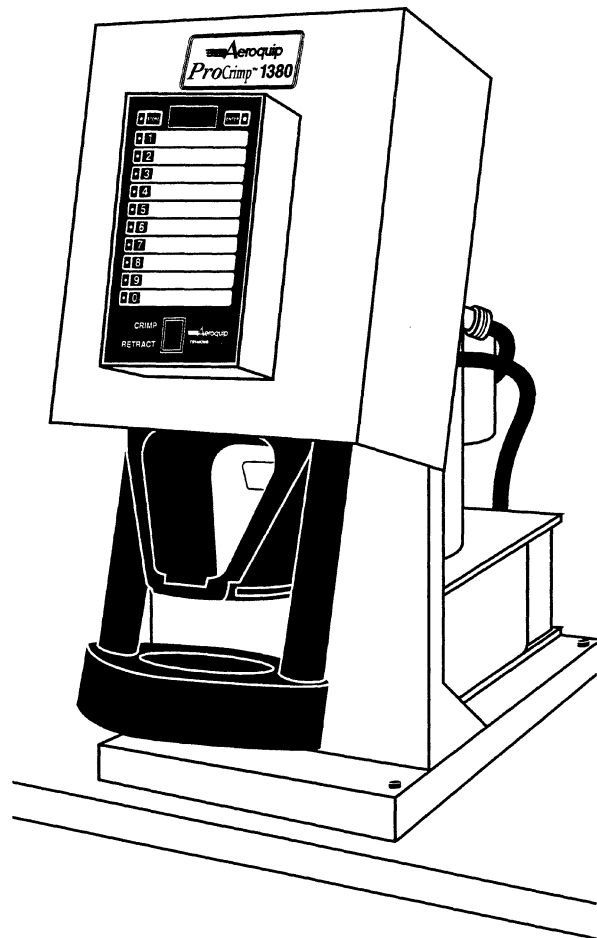

# Aeroquip

## Aeroquip ProCrimp™ 1380 Crimp Machine

## Operators Manual



### Table of Contents

Safety Instructions .....	2
Specifications .....	3
Accessories .....	3
Setup and Installation .....	3
Operating Instructions	
Loading and Unloading Die Cages .....	4
Operating the Keypad .....	4-5
Entering a Number into the Display .....	5
Storing a Number from the Display .....	5
Recalling a Preset into the Display .....	5
Crimping Procedures .....	6
Calibration .....	7
Maintenance	
Maintenance Intervals .....	8
Machine Maintenance Procedures .....	8
Die Cage Maintenance Procedures .....	8
Troubleshooting Tips .....	9
Crimp Machine Components .....	10
Die Cage Components .....	11
Electrical Schematics .....	12-13
Hydraulic Schematic .....	13



## WARNING

Failure to follow Aeroquip process and product instructions and limitations could lead to premature hose assembly failures, resulting in property damage, serious injury or death.

Aeroquip fitting tolerances are engineered to match Aeroquip hose tolerances. The use of Aeroquip fittings on hose supplied by other manufacturers and/or the use of Aeroquip hose with fittings supplied by other manufacturers, may result in the production of unreliable and unsafe hose assemblies and is neither recommended nor authorized by Aeroquip.

Read and understand the operator's manual before attempting to operate any equipment.

*Aeroquip hereby disclaims any obligation or liability (including incidental and consequential damages) arising from breach of contract, warranty, or tort (under negligence or strict liability theories) should Aeroquip hose, fittings or assembly equipment be used with the hose, fittings or assembly equipment supplied by another manufacturer, or in the event that product instructions for each specified hose assembly are not followed.*

## Safety Instructions

1. **PREVENT UNAUTHORIZED OPERATION.** Do not permit anyone to operate this equipment unless they have read and thoroughly understand this manual.
2. **WEAR SAFETY GLASSES.**
3. **AVOID PINCH POINTS.** Do not rest your hand on the crimp ring. Keep your hands clear of all moving parts. Do not allow anyone, other than the operator, close to the equipment while it is in operation.
4. **MAINTAIN DIES WITH CARE.** Dies used in the FT1380 crimp machine are hardened steel, offering the best combination of strength and wear resistance for long life. Hardened dies are generally brittle and care should be taken to avoid any sharp impact. Never strike a die with a hardened instrument.
5. **USE ONLY SPECIFIED AEROQUIP PRODUCTS.** Make hose assemblies using only Aeroquip hose and fittings specified for this assembly equipment.
6. **VERIFY CORRECT CRIMP DIAMETERS.** Check and verify correct crimp diameters of all fittings after crimping. Do not put any hose assemblies into service if the crimp diameters do not meet Aeroquip crimp specifications.
7. Make sure all dies are completely in place and the cage is positioned properly on the pressure plate.
8. **DO NOT OVER PRESSURIZE.** Do not exceed the 10,000 psi hydraulic pressure supplied to the machine. This setting is preset at the factory and should not require adjustment.  
  
NOTE: All components used to connect the pump and crimp cylinder must meet the criteria set forth in the Material Handling Institute Specification #IJ100 for hydraulic jacking applications.
9. **DIE CHANGE.** Do not insert/remove dies while the power is on.
10. **SECURE THE EQUIPMENT TO A STABLE WORK SURFACE.** Prior to operation, secure the crimp machine to a stable work surface to prevent the equipment from tipping.
11. **UNPLUG THE POWER SUPPLY WHEN NOT IN USE.**
12. **KEEP WORK AREA CLEAN.** Cluttered areas and benches invite accidents.

## Specifications

### Electrical Requirements:

FT1380-115	115-Volt AC single phase (50/60) Hz Circuit with a minimum of 20 amps
FT1380-230	208 to 230-Volt AC single phase (50/60) Hz Circuit with a minimum of 15 amps

### Crimp Machine Dimensions:

Width –	12.75 inches
Depth –	25.75 inches
Height –	28.50 inches
Weight –	238 pounds

### Production Capacity:

- All Aeroquip MatchMate Plus braided and spiral hose through -20 size
- Flat field crimp thru -16
- Barrel field crimp thru -20
- Flat single skive 1 & 2-wire braid crimp thru -20
- Flat single skive 4-wire spiral crimp thru -16

Unit will not crimp:

- Internal skive fittings
- Hose that requires a positive stop, including the following Aeroquip hoses: 2807, 2808, FC186, FC465, FC469, and FC505

## Setup and Installation

1. Mount your Aeroquip ProCrimp 1380 crimp machine onto a workbench that will support at least 300 pounds. Secure the unit using the holes provided in the corners of the crimp machine base.
2. Remove the plug from the hydraulic reservoir vent port and replace it with the vent cap that is supplied with the unit.



**CAUTION:** Failure to do so will cause cavitation and damage to the pumping mechanism. Hand tighten the vent cap.

3.



**CAUTION:** Provide electrical service with a dedicated circuit (per the crimp machine electrical requirements) to eliminate the possibility of a low-voltage situation.

4. Never use an extension cord, always plug directly into the power outlet.

## Accessories

### Die Cage Conversion Kit

For conversion of any FT1330 die cage for use with the Aeroquip ProCrimp 1380 crimp machine. Contains components necessary to convert one die cage.

Part Number ..... FT1380-2-3

### Die Holder Kit

A set of four plates and mounting hardware that can hold up to eight die cages. This kit attaches to the sides of the Aeroquip ProCrimp 1380 crimp machine.

Part Number ..... FT1380-2-4

### Die Cages

Part Number .....	FT1380-200-M070
.....	FT1380-200-M090
.....	FT1380-200-M120
.....	FT1380-200-M150
.....	FT1380-200-M180
.....	FT1380-200-M210
.....	FT1380-200-M240
.....	FT1380-200-M280
.....	FT1380-200-M320
.....	FT1380-200-M370
.....	FT1380-200-M420
.....	FT1380-200-M465

## Operating Instructions

### Loading and Unloading Die Cages

To load the die cage, press and hold the RETRACT switch (figure 1) until the crimp ring reaches the “full retract” position and stops. The die cage may be inserted or removed in this position (figure 2 and 4). To minimize cycle time during normal operation, the Aeroquip ProCrimp 1380 crimp machine automatically retracts to a predetermined “soft retract” (figure 3) that allows easy insertion and removal of hose and fittings. **NOTE:** The die cage cannot be removed while the machine is in the “soft retract” position.

### Operating the Keypad

1. The DISPLAY shows the three-digit setting that will determine the crimp diameter. The ratio of crimp diameter change to the DISPLAY change is 1 to 1. For example, if you crimp a fitting at a setting of 120, and the crimp diameter is .035 inch too large, you will need to decrease the DISPLAY by .035 to  $(120 - 035) = 085$ . A display of 085 should produce the correct crimp diameter.
2. The STORE button is used to store the DISPLAY reading in any of the 10 numbered keys. The green light next to the STORE button will illuminate when you are working in the STORE mode.

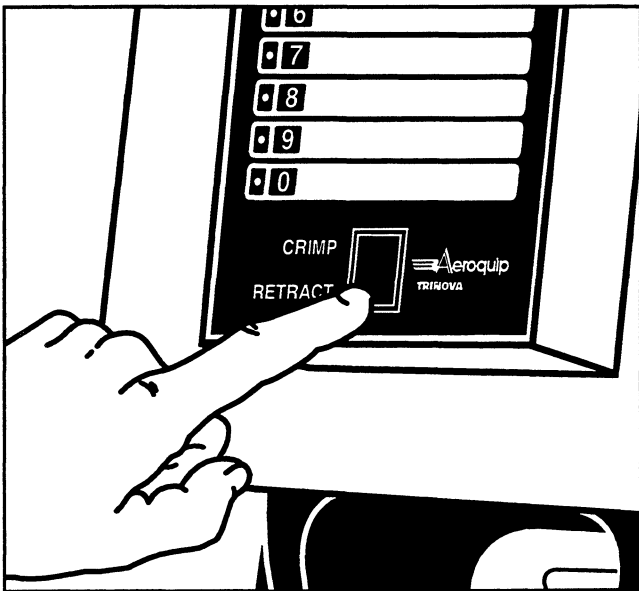

Figure 1

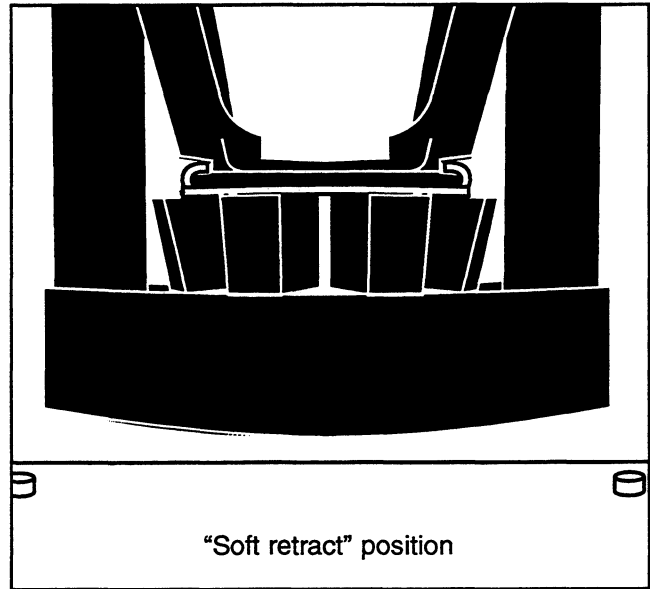

Figure 3

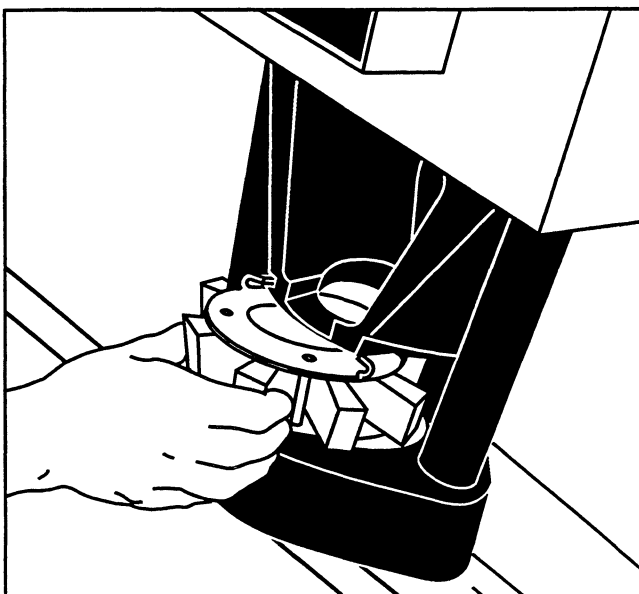

Figure 2

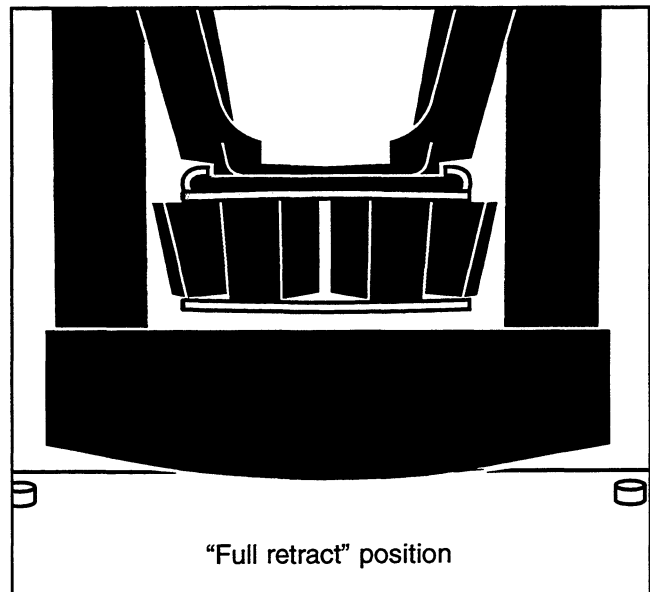

Figure 4

3. The ENTER button is used to put any three-digit number into the DISPLAY. The green light next to the ENTER button will illuminate when you are working in the ENTER mode.
4. The numbered keys have two functions:
  - a. In the ENTER mode, their numeric value is put into the DISPLAY.
  - b. In the STORE mode, they act as 10 different locations in which to store a DISPLAY setting.

### Entering a Number into the Display

1. Turn the power control switch on the back of the crimp machine to the ON position. The work light and the DISPLAY will illuminate to show that the power is on.
2. Press the ENTER button (the green light next to the ENTER button will illuminate).
3. Press three numerical buttons in less than five seconds. (If more than five seconds elapse, the display reverts back to its previous setting.) After the third number is entered, the display will remain.
4. The FT1380 is now ready to crimp to the DISPLAY setting.

### Storing a Number from the Display as a Preset

1. Enter a three-digit number as described in the procedure above.
2. Press the STORE button. (The green light next to the STORE button will illuminate.)
3. Press and hold down any one of the ten numerical buttons for three seconds. (At the end of three seconds, the green light next to button will illuminate, indicating that the display has been stored to that button.)

### Recalling a Preset into the Display

1. Make sure that the STORE and ENTER lights are off. (If one is on, it will go off in five seconds if left untouched.)
2. Press the button that has the stored setting for a given hose and fitting style. This setting will then be seen in the DISPLAY.

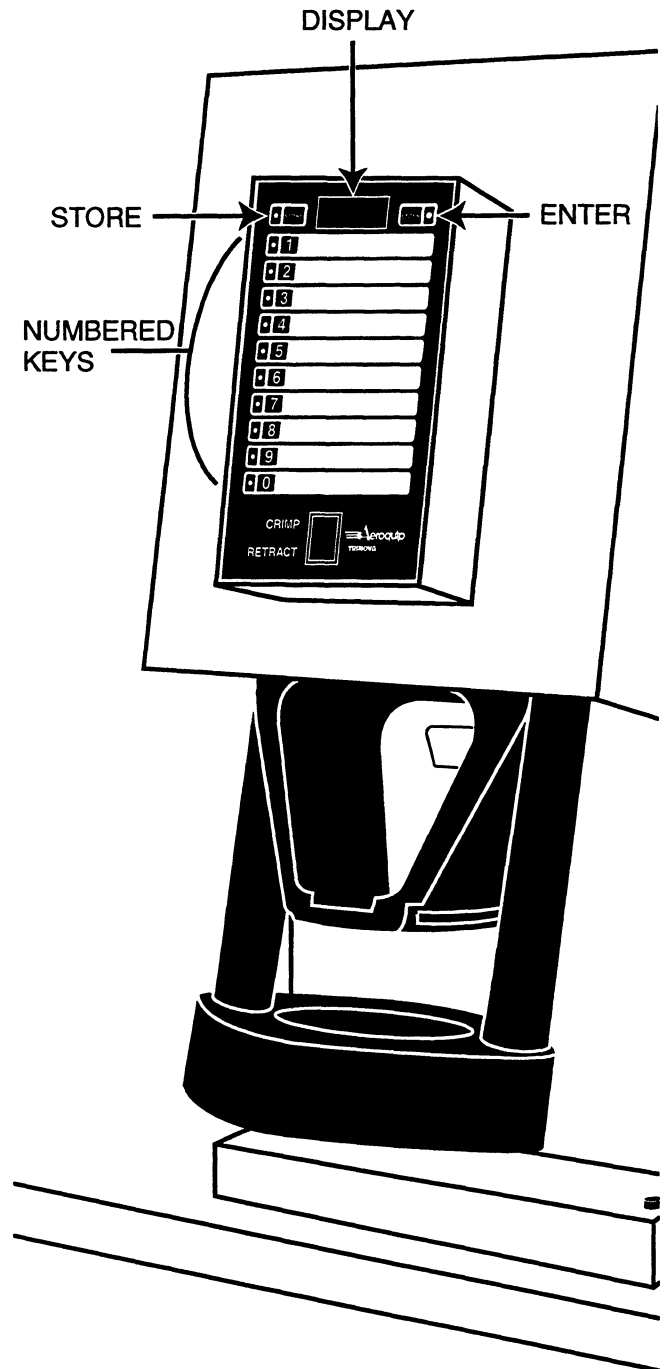

## Crimping Procedures



**WARNING: Maintain clear distance from all moving parts.**

Refer to the current Aeroquip Crimp Specifications bulletin for complete and detailed crimp specification information for each hose and fitting style.

1. Retract the crimp ring by depressing the retract switch until the crimp ring is fully retracted. Select the proper die cage from the current Aeroquip Crimp Specifications bulletin. Slide the die cage into the cage holder slots.
2. Press the proper PRESET button or key in a value to the DISPLAY (see example). MatchMate Plus and MatchMate Blue target setting charts are available from Aeroquip.
3. Position the fitting within the crimp cage according to the corresponding figure in the current Aeroquip Crimp Specifications bulletin. (A MatchMate Plus fitting is shown in figure 5).
4. To crimp the fitting, depress the CRIMP switch. The crimp ring will rise until the fitting is fully crimped (figure 6). It will then stop and begin to retract, signifying that the crimp is complete. Remove your finger from the CRIMP switch. The crimp ring will automatically retract and stop at the "soft retract" position (about 1/2-inch short of being fully retracted).

HINT: Retraction can be halted at any point by momentarily depressing the RETRACT switch, and then resumed by depressing and holding the RETRACT switch.

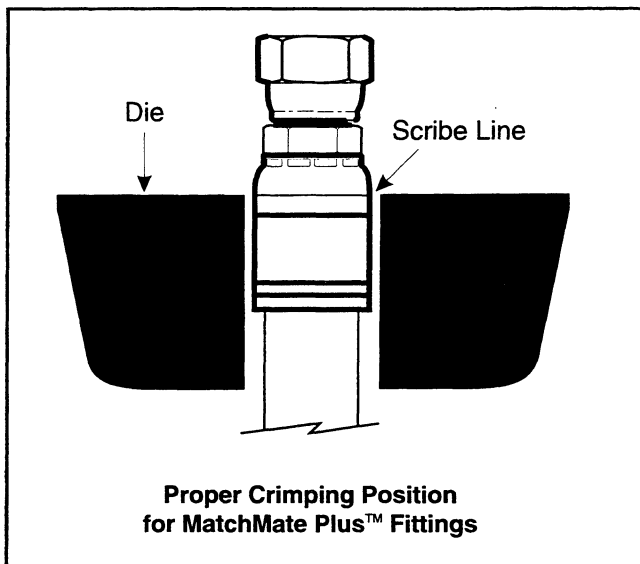

Figure 5

5. Verify correct crimp diameter.

REMINDER: Full retraction is required for changing die cages.

### Example:

Enter the number "300" into the DISPLAY and start the crimping process. If the dies crimp the fitting, measure the crimp diameter and decrease the DISPLAY setting by the same amount that you wish to decrease the crimp diameter. If the dies don't touch the fitting, lower the DISPLAY setting by 050 to "250" and try to crimp the fitting again. If that still isn't enough, continue to reduce the DISPLAY setting by 050 increments until the dies make contact with the fitting. Then, measure the crimp diameter and decrease the DISPLAY setting by the same amount that you wish to decrease the crimp diameter.

If a display setting of "250", using GH793-8 hose with TTC fittings produces a crimp diameter of 1.124 inches, subtract the crimp specification (0.990 inches) from the diameter that you measured ( $1.124 - 0.990 = 0.134$ ). Then, subtract "134" from the DISPLAY setting ( $250 - 134 = 116$ ) and change the DISPLAY to "116". Crimp the fitting again and measure the crimp diameter. If the crimp diameter is still too large, repeat this process.

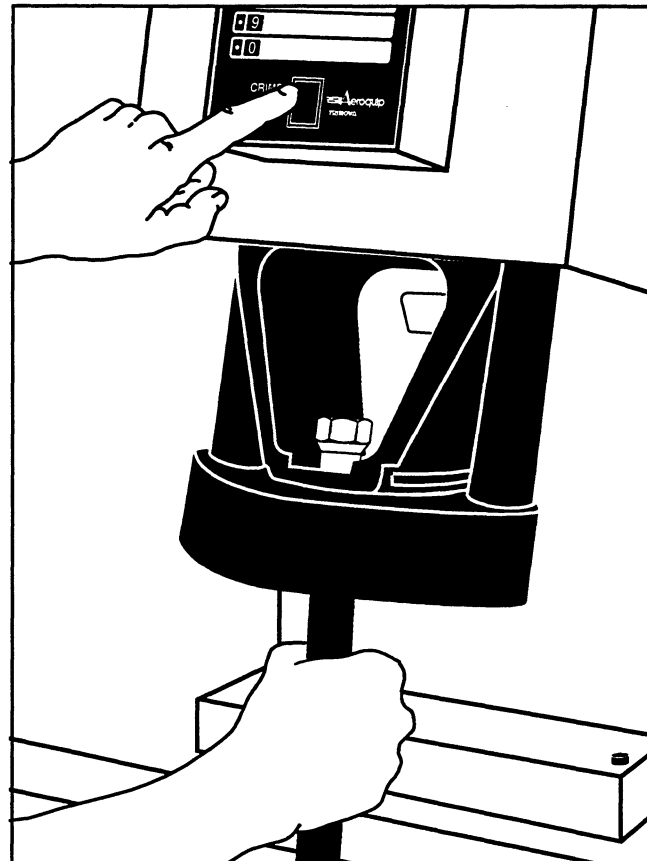
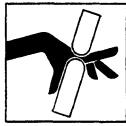

Figure 6

## Calibration



**WARNING: Maintain clear distance from all moving parts.**

The calibration procedure below will calibrate the Aeroquip ProCrimp 1380 crimp machine to the original factory setting. While new machines are calibrated at the factory and will be ready to use out of the crate, this procedure should be followed if the crimp machine has been disassembled or has had components replaced. The procedure requires the use of an FT1380-200-M240 die cage, a 1SB8 socket (or TTC-8 fitting), and a 1SB12 socket (or a TTC-12 fitting).

**CAUTION:** While in the calibration mode, follow the instructions precisely and press the keys deliberately. If a mistake is made, the calibration procedure must be started over from the beginning.

### PART I

1. Insert an FT1380-200-M240 die cage.
2. Press the STORE and ENTER buttons simultaneously, then release. Both button lights will now be illuminated and will remain so until the calibration procedure is finished.
3. Enter in the value of '100' using the keypad.
4. Center a 1SB8 socket or TTC-8 fitting (without a hose) in the die cage, holding the socket or fitting in place with a pencil or other suitable tool. Crimp the socket by depressing the crimp switch until the machine retracts by itself, indicating a completed cycle. Allow the crimp ring to return to the "soft retract" position.
5. Using a set of calipers, measure the crimp diameter. The preferred method is to use the average of the four pairs of indentations.
6. Locate the crimp diameter in Table A, below. Using the keypad, enter in the three-digit Display Reading that corresponds to the Crimp Diameter.

**NOTE:** If your Crimp Diameter falls between the numbers shown in Table A, simply determine or interpolate the Display Reading, since the numbers are a direct ratio.

Crimp Diameter	Display Reading
0.940	040
0.950	050
0.960	060
0.970	070
0.980	080
0.990	090
1.000	100
1.010	110

Crimp Diameter	Display Reading
1.240	340
1.250	350
1.260	360
1.270	370
1.280	380
1.290	390
1.300	400
1.310	410

## PART II

1. Enter in the value of '400' using the keypad.
2. Center a 1SB12 socket or TTC-12 fitting (without a hose) in the die cage, holding the socket or fitting in place with a pencil or other suitable tool. Crimp the socket by depressing the crimp switch until the machine retracts by itself, indicating a completed cycle.
3. Repeat steps 5 and 6 at left, except use Table B instead of Table A for the -12 socket.
4. After the three-digit Display Reading is entered, the machine will automatically exit the calibration mode.

### Calibration Example:

#### Part I

Crimp a 1SB8 socket and measure the four crimp diameters around the socket. Let's say, for example, that the diameters measure .942, .946, .945 and .945 inches. To obtain the average diameter, add the four diameters and divide that sum total by 4.

$$\frac{(.942 + .946 + .945 + .945)}{4} = \frac{3.778}{4} = 0.9445 = 0.945$$

(round to nearest thousandth)

Look at the Crimp Diameter column in Table A and find your average diameter. If it falls between two numbers, as this one does, interpolate the desired setting. In this case, you would enter 045. If your crimp diameter was .940, you would enter 040; if it was .942, you would enter 042.

#### Part II

Crimp a 1SB12 socket and measure the four crimp diameters around the socket. This time, let's say that the diameters measure 1.247, 1.249, 1.249 and 1.248 inches. Average the measures by adding the four diameters and dividing that sum total by 4.

$$\frac{(1.247 + 1.249 + 1.249 + 1.248)}{4} = \frac{4.993}{4} = 1.24825 = 1.248$$

(round to nearest thousandth)

Look at the Crimp Diameter column in Table B and find your average diameter. If it falls between two numbers, as this one does, interpolate the desired setting. In this case, you would enter 348. If your crimp diameter was 1.250, you would enter 350; if it was 1.249, you would enter 349.

## Maintenance Intervals

### Die Cage Lubrication

Every 50 crimps Relube sliding surfaces of dies

Every 500 crimps Remove old grease and relube

Every 1000 crimps Die cage maintenance

### Crimp Ring Maintenance

Every 500 crimps Remove old grease and relube

Every 2000 crimps Remove old grease, inspect for wear or damage and relube if okay

Use NEVER•SEEZ lubricant (Aeroquip part number FT1092).

---

## Maintenance Procedures

### Machine Maintenance Procedures

1. Sliding surfaces must be kept free of dirt and other abrasive materials.
2. All exposed black metal surfaces should be coated occasionally with a light film of oil to prevent corrosion.
3. Periodically check the oil level in the fluid reservoir of the hydraulic power unit. Maintain the oil level according to the indicator on top of the reservoir. Add ENERPAC hydraulic oil as needed.

NOTE: Completely retract the crimp ring when checking the oil level.

### Die Cage Maintenance Procedures

1. Lubricate the die cage. For maximum service, FT1380 die cages require lubrication at 50-crimp intervals with NEVER•SEEZ (Aeroquip part number FT1092). FT1092 is an 8-ounce container that will provide sufficient lubricant for about 5,000 crimps.

Periodically remove NEVER•SEEZ residue that has built-up on the sides of the dies in the crimp ring during the crimping process. NEVER•SEEZ residue becomes contaminated with metal and plating chips and airborne contaminants, which can cause premature wear of the dies and crimp ring. It should

carefully be removed without mixing it with newly applied NEVER•SEEZ.

2. Die cage maintenance should be performed at 1000-crimp intervals or every six months, whichever ever occurs first. Die cages should be clean of grease and debris and inspected for worn or damaged components.
  - a. The sliding surface of the dies should appear smooth with no apparent galling. Galled dies must be replaced. Individual dies in a cage can be replaced without replacing all eight dies.
  - b. Replace springs that show any sign of damage or collapse (are shorter than the other springs).
  - c. The spring plate should appear smooth with no apparent galling. Galled spring plates must be replaced.
  - d. Inspect remaining components and replaced those that are badly worn.

Reassemble components and liberally apply NEVER•SEEZ to the die surface which slides along the spring plate. Torque the die cage bolts to 50 in.-lbs.

Ensure that all dies slide in and out freely.



## Troubleshooting Tips

Remember: The electric motor only runs during the crimping process. The motor energizes when the crimp switch is pressed and de-energizes when the crimp switch is released or when the crimp cycle is completed. While

crimping, the hydraulic dump valve is also energized. When the valve is energized, oil flow is directed from the pump to the cylinder. When the valve is de-energized, oil flows from the cylinder back to the reservoir.

Symptom	Possible Cause	Corrective Action
Pump will not start	<ul style="list-style-type: none"> <li>No power or wrong voltage</li> </ul>	<ul style="list-style-type: none"> <li>Make sure unit is plugged in</li> <li>Make sure that the power source is on</li> <li>Make sure that the power voltage is correct</li> <li>Check for loose wires on the circuit board</li> <li>Check for loose wires on the CRIMP switch</li> </ul>
Motor stalls under load	<ul style="list-style-type: none"> <li>Low voltage</li> </ul>	<ul style="list-style-type: none"> <li>Verify that the branch circuit conforms to the electrical specifications on page 3 of this manual</li> <li>Remove any extension cord</li> </ul>
Electric valve will not operate	<ul style="list-style-type: none"> <li>No power or wrong voltage</li> <li>Low voltage</li> </ul>	<ul style="list-style-type: none"> <li>Check for loose wires on the circuit board</li> <li>Check for loose wires on the CRIMP switch</li> <li>Make sure that the power voltage is correct</li> </ul>
Pump fails to build pressure	<ul style="list-style-type: none"> <li>External leak in system</li> <li>Internal leak in pump</li> <li>Internal leak in valve</li> <li>Internal leak in system component</li> </ul>	<ul style="list-style-type: none"> <li>Wipe away spilled oil and locate the source of the leak. If the hose assembly is leaking, tighten or replace it. If the pump or cylinder is leaking, refer to the ENERPAC Repair Parts Sheets. Slight oil seepage of the cylinder is normal.</li> </ul>
Pump builds less than full pressure	<ul style="list-style-type: none"> <li>Relief valve set low</li> <li>External system leak</li> <li>Internal leak in pump</li> <li>Internal leak in valve</li> <li>Internal leak in system component</li> </ul>	<ul style="list-style-type: none"> <li>Refer to the ENERPAC Repair Parts Sheets for possible adjustment or leakage repair</li> </ul>
Pump builds full pressure, but load does not move	<ul style="list-style-type: none"> <li>Tie rods may be binding</li> <li>Flow to cylinder blocked</li> </ul>	<ul style="list-style-type: none"> <li>Replace the crimp ring, tie rods and top bar.</li> <li>Refer to the ENERPAC Repair Parts Sheets.</li> </ul>
Cylinder drifts back on its own	<ul style="list-style-type: none"> <li>External system leak</li> <li>Internal leak in a system component</li> </ul>	<ul style="list-style-type: none"> <li>Wipe away spilled oil and locate the source of the leak. If the hose assembly is leaking, tighten or replace it. If the pump or cylinder is leaking, refer to the ENERPAC Repair Parts Sheets. Slight oil seepage of the cylinder is normal.</li> </ul>
Cylinder will not return	<ul style="list-style-type: none"> <li>Valve malfunction</li> <li>Cylinder return spring broken</li> <li>Return flow restricted/blocked</li> <li>Tie rods may be binding</li> <li>Die cage may be binding</li> </ul>	<ul style="list-style-type: none"> <li>Refer to the ENERPAC Repair Parts Sheet for valve or cylinder repair.</li> <li>Replace the crimp ring, tie rods and top bar.</li> <li>Check the die cage and crimp ring for damage and repair or replace if necessary.</li> <li>Lubricate the die cage per the maintenance procedures on page 8 of this manual.</li> </ul>
Crimp diameters change	<ul style="list-style-type: none"> <li>Incorrect hose/fitting combination</li> <li>Incorrect die cage</li> <li>Die or crimp ring damage</li> <li>Transducer is loose</li> <li>Loose crimp machine components</li> <li>External damage to crimp machine</li> <li>Insufficient lubrication on dies</li> </ul>	<ul style="list-style-type: none"> <li>Verify correct hose/fitting combination.</li> <li>Verify correct die cage.</li> <li>Repair or replace the damaged components.</li> <li>Tighten the transducer and brackets, then recalibrate if necessary.</li> <li>Tighten any loose bolts or screws</li> </ul>
DISPLAY blinks	<ul style="list-style-type: none"> <li>Loose or broken wires</li> </ul>	<ul style="list-style-type: none"> <li>Tighten any wires that may have become loose on the circuit board, pump electrical enclosure, or CRIMP switch.</li> </ul>

If the symptom appears to be solely pump or cylinder related, refer to the ENERPAC Repair Parts Sheets.

Any electrical checks must be done by a qualified electrician.

## Crimp Machine Components

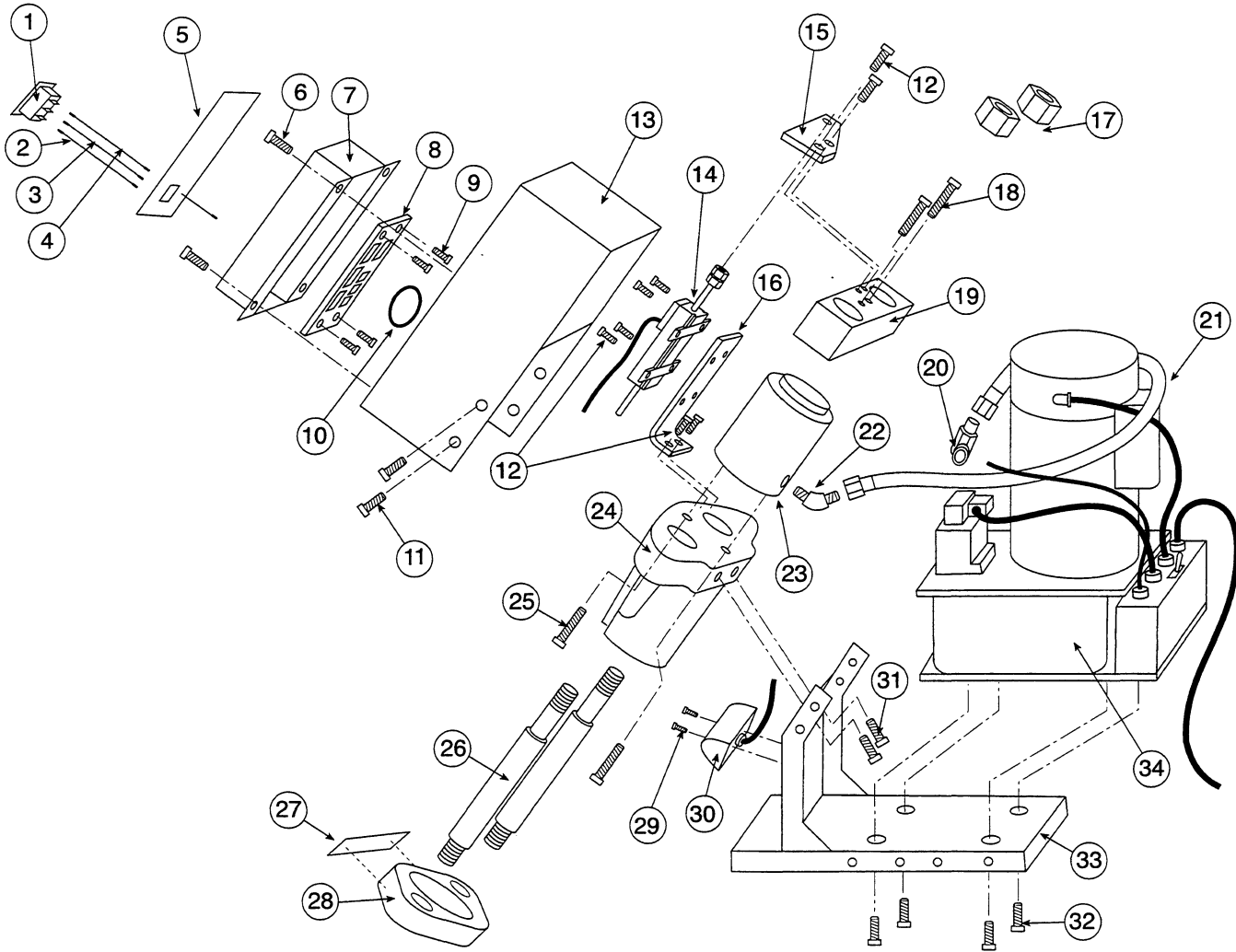

Item	Qty	Part Number	Description
1	1	FT1380-3-3	Switch
2	1	FT1380-3-31	Wire, Red 16 ga. 4.5" Long
3	1	FT1380-3-32	Wire, White 16 ga. 5" Long
4	1	FT1380-3-33	Wire, Red 16 ga. 5.5" Long
5	1	FT1380-3-6	Keypad
6	4	FT1380-3-23	Screw 8-32 X 3/8" Stainless SHCS
7	1	FT1380-3-7	Electrical Enclosure
8	1	FT1380-3-4	Circuit Board Assembly
9	4	FT1380-3-18	Screw 4-40 X 3/16" SHCS
10	1	FT1380-3-29	Grommet
11	4	FT1380-3-24	Screw 1/4-20 X 3/8" Stainless SHCS
12	8	FT1380-3-26	Screw 8-32 X 3/8" SHCS
13	1	FT1380-3-11	Main Guard
14	1	FT1380-3-5	Transducer Assembly
15	1	FT1380-3-17	Bracket, Transducer Rod
16	1	FT1380-3-16	Bracket, Transducer
17	2	FT1380-3-21	Nut

Item	Qty	Part Number	Description
18	2	FT1380-3-22	1/4-20 X 2 1/2" SHCS
19	1	FT1380-3-15	Top Bar
20	1	FF2032T0606S	Adapter
21	1	1C02217GGG0310	Hose Assembly
22	1	FF2093T0606S	Adapter
23	1	FT1380-3-2	Cylinder Assembly
24	1	FT1380-3-12	Pusher
25	2	FT1380-3-19	Screw 3/8-16 X 1 1/2" SHCS
26	2	FT1380-3-14	Tie Rod
27	1	FT1289-3-60	CAUTION Decal
28	1	FT1380-3-13	Crimp Ring
29	2	FT1380-3-27	Screw 6-32 X 1/2" SHCS
30	1	FT1380-3-8	Work Light
31	2	FT1380-3-25	Screw 1/2-13 X 1" SHCS
32	4	FT1380-3-20	Screw 3/8-16 X 3/4" SHCS
33	1	FT1380-3-9	Frame
34	1	FT1380-3-1	Hydraulic Pump Assembly 115V or FT1380-3-35 Hydraulic Pump Assembly 230V

## Die Cage Components

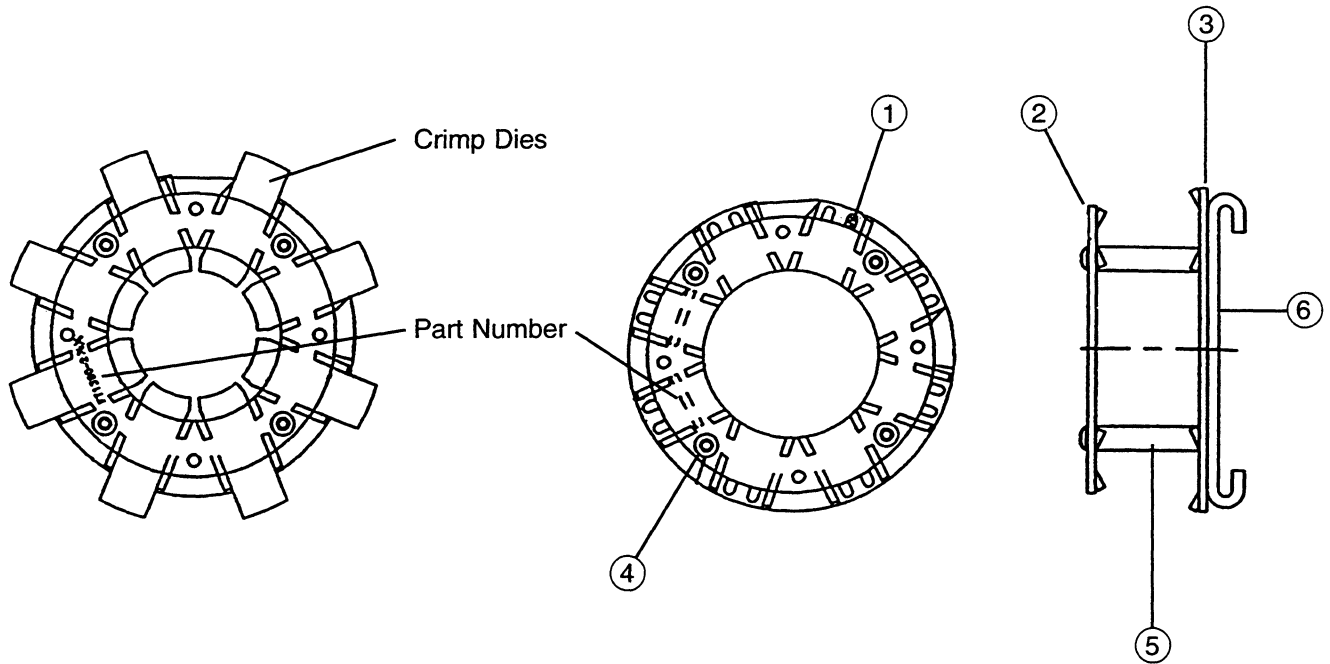

Detail Number	FT1380-2-9 Bill of Material	FT1380-2-9A Bill of Material	Description	Quantity Required
1	FT1330-2-9-21	FT1330-2-9-2	Die spring	8 or 16*
2	FT1380-2-9-3	FT1380-2-9-2	Front plate	1
3	FT1330-2-9-13	FT1330-2-9-3	Spring plate	1
4	FT1330-2-9-55	FT1330-2-9-5	Button Head Cap Screw	4
5	FT1330-2-9-66	FT1330-2-6-6	Spacers	4
6	FT1380-2-9-1	FT1380-2-9-1	Back plate	1

\*The FT1380-200-NO. (FT1380-2-9) requires 16 springs and the FT1380-201-NO. (FT1380-2-9A) requires 8 springs.

## Electrical Schematic for FT1380-115 (115V model)

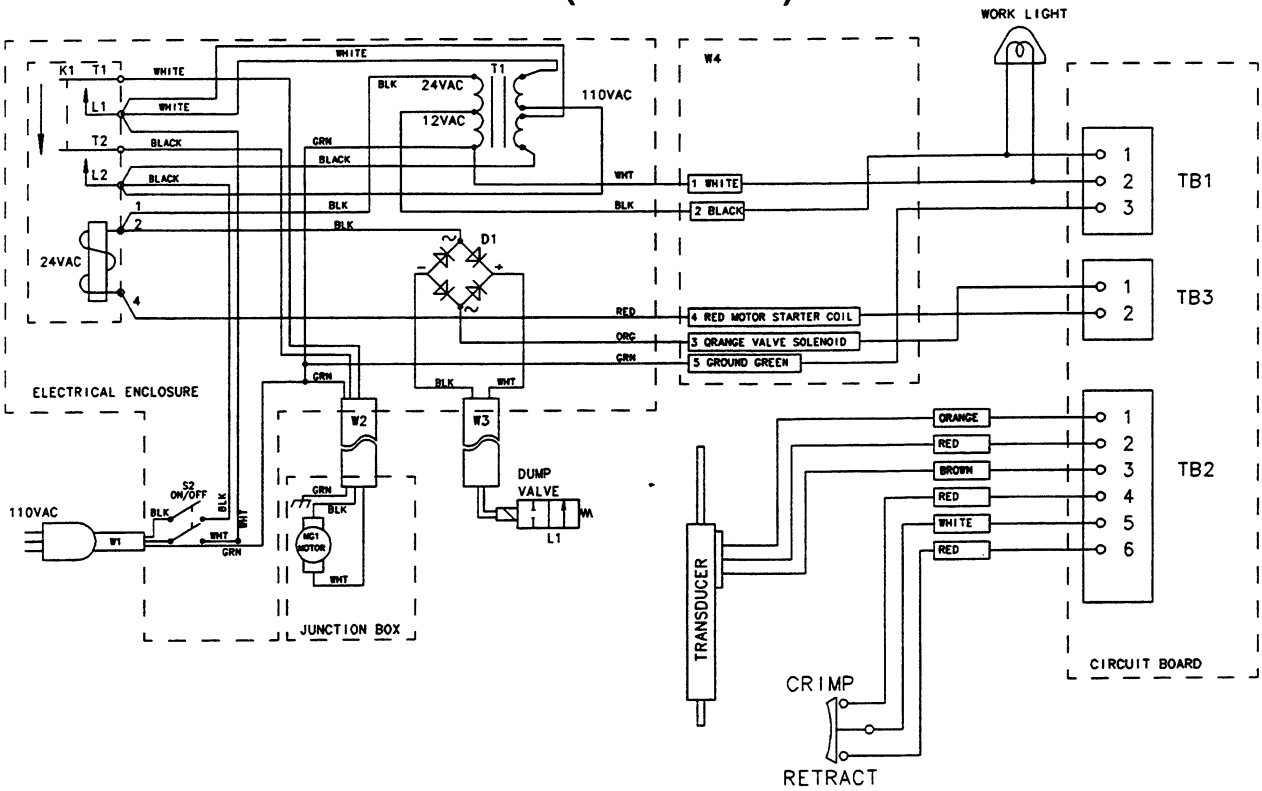

## Electrical Schematic for FT1380-230 (230V model)

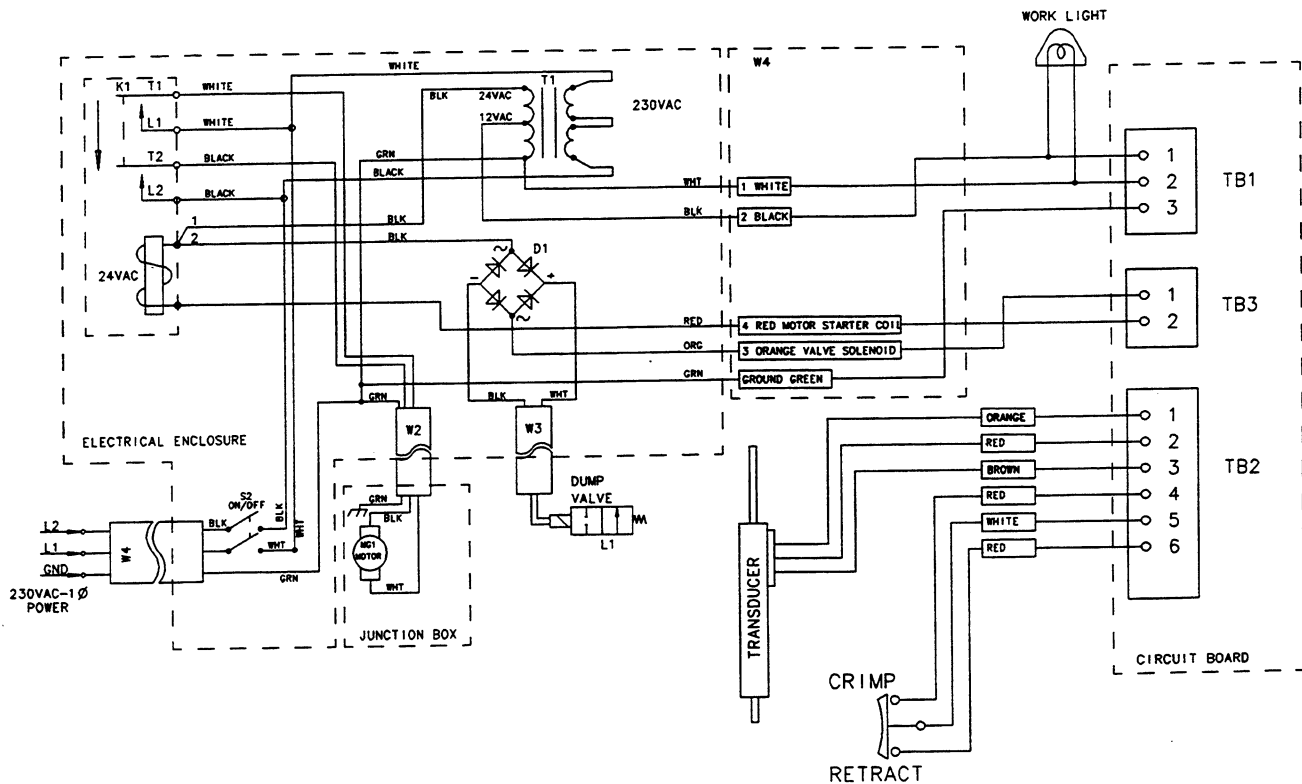

## Electrical Schematic – Terminal Blocks and Pin Numbers (115V and 230V models)

Terminal Block	Pin Number	Voltage	Wire Color	Description
TB1	1	+12V AC	Black	From transformer
			Black	To work light
TB1	2	+0V AC	White	From transformer
			White	To work light
TB1	3	None	Green	To earth ground
TB2	1	+4.04V DC	Orange	To transducer
TB2	2	+4.04 to 0.04V DC*	Red	To transducer
TB2	3	+0.04V DC	Brown	To transducer
TB2	4	+5V DC	Red	Crimp switch
TB2	5	0V DC	White	Switch common
TB2	6	+5V DC	Red	Retract switch
TB3	1	+24V AC	Orange	To dump valve
TB3	2	+24V AC	Red	To motor contractor

\*The voltage at TB2 pin 2 varies between 4.04V DC and 0.04V DC, depending on the position of the crimp ring.

## Hydraulic Schematic

### SEQUENCE

1. PUMP ON - CYLINDER ADVANCES.
2. VALVE ENERGIZED - CYLINDER RETRACTS.
3. PUMP AND VALVE DE-ENERGIZED - CYLINDER HOLDS POSITION.

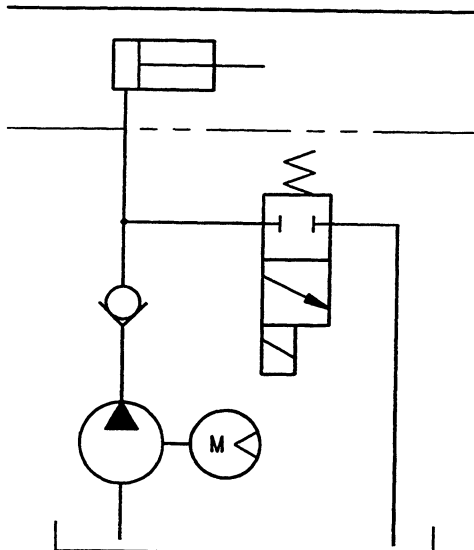

**NOTES**

**NOTES**

---

Eaton  
14615 Lone Oak Road  
Eden Prairie, MN 55344  
USA  
Tel: 952 937-9800  
Fax: 952 974-7722  
[www.hydraulics.eaton.com](http://www.hydraulics.eaton.com)

Eaton  
20 Rosamond Road  
Footscray  
Victoria 3011  
Australia  
Tel: (61) 3 9319 8222  
Fax: (61) 3 9318 5714

Eaton  
Dr.-Reckeweg-Str. 1  
D-76532 Baden-Baden  
Germany  
Tel: (49) 7221 682-0  
Fax: (49) 7221 682-788