

Hose Sleeves and Guards

Round Wire Spring Guard

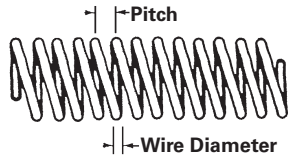
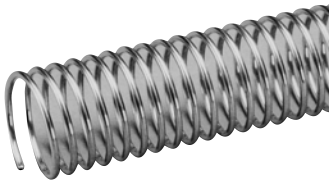

Spring guards should be considered for those applications which call for tough, steel armor protection. They offer heavy-duty hose defense against cuts and abrasion, with the added benefit of kink resistance and the ability to mold hose assembly routing for applications which require tight bends.

Material: Hot Dipped Galvanized steel, chemically treated and oiled.

GUARD I.D.	CATALOG NUMBER	PACKAGE LENGTH (FT)	WIRE DIAMETER	PITCH
.515	A1900	100'	.063	.188
.515	A1900-20	20'	.063	.188
.550	A1901	100'	.063	.188
.550	A1901-20	20'	.063	.188
.610	AS1902	100'	.063	.188
.610	A1902-20	20'	.063	.188
.650	A1903	100'	.080	.188
.650	A1903-20	20'	.080	.188
.750	A1904	100'	.080	.188
.750	A1904-20	20'	.080	.188
.835	A1905	100'	.080	.188
.835	A1905-20	20'	.080	.188
.900	A1906	100'	.080	.188
.900	A1906-20	20'	.080	.188
.990	A1907	100'	.080	.188
.990	A1907-20	20'	.080	.188
1.055	A1908	100'	.080	.188
1.055	A1908-20	20'	.080	.188
1.110	A1909	100'	.080	.250
1.110	A1909-20	20'	.080	.250
1.240	A1910	100'	.080	.250
1.240	A1910-20	20'	.080	.250
1.300	A1911	60'	.120	.375
1.300	A1911-20	20'	.120	.375
1.380	A1912	60'	.120	.375
1.630	A1913	60'	.120	.375
1.810	A1915	60'	.120	.375
2.000	A1916	40'	.120	.375
2.125	A1917	40'	.120	.375
2.300	A1919	40'	.120	.375

Flat Wire Spring Guard

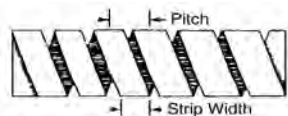

Spring guards should be considered for those applications which call for tough, steel armor protection. They offer heavy-duty hose defense against cuts and abrasion, with the added benefit of kink resistance and the ability to mold hose assembly routing for applications which require tight bends.

GUARD I.D.	CATALOG NUMBER	PACKAGE LENGTH (FT)	STRIP THICKNESS	STRIP WIDTH	PITCH
.515	A2900	100'	.028	.375	.500
.550	A2901	100'	.028	.375	.500
.610	A2902	100'	.028	.375	.500
.650	A2903	100'	.028	.375	.500
.750	A2904	100'	.028	.375	.500
.835	A2905	100'	.028	.500	.688
.900	A2906	100'	.028	.500	.688
.990	A2907	100'	.028	.500	.688
1.055	A2908	100'	.028	.500	.688
1.110	A2909	100'	.028	.500	.688
1.240	A2910	100'	.028	.500	.688
1.300	A2911	60'	.028	.500	.688
1.380	A2912	60'	.042	.500	.812
1.630	A2913	60'	.042	.500	.812
2.125	A2917	40'	.042	.500	.812
2.300	A2919	40'	.042	.500	.812

Hose Sleeves and Guards

Heavy Duty Poly Hose Guard

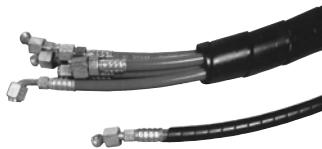

Poly Hose ID

Heavy Duty Hose Guard can be easily placed around a single or bundle of hydraulic and pneumatic hoses. It protects against abrasion, and also provides crush resistance, reducing or eliminating costly premature hose failures.

Features: Resists oils, lubricants, gasoline and most solvents.

Temperature: -100°F to +220°F

Color: Black

Material: High Density Polyethylene

GUARD I.D.	CATALOG NUMBER	WALL THICKNESS	GUARD I.D.	FOOT/ROLL
.492	A9900	.069	.630	100'
.668	A9901	.086	.840	100'
1.014	A9902	.118	1.250	100'
1.600	A9903	.150	1.900	50'
2.457	A9904	.209	2.875	50'
3.065	A9905	.218	3.500	35'

Abrasion Sleeve

MSHA Accepted
ISO 6945



A hose protection product used to help safeguard hose covers from abrasions and cuts. Typical areas of use include agricultural, logging, construction and mining applications. The abrasion sleeve is also useful for bundling two or more hose assemblies together, in addition to the protective qualities the sleeving provides. Available in .045" thin wall and .090" thick wall sleeving.

Material: Bulk continuous filament nylon.

Note: Wall thickness is for single wall.

SLEEVE I.D.	.045" THIN WALL CATALOG NO.	.090" THICK WALL CATALOG NO.	PACKAGE* LENGTH (FT)	FLAT I.D. (INCH)
.90	A4900	A3900	100'	1.32-1.51
1.06	A4901	A3901	100'	1.57-1.76
1.22	A4902	A3902	100'	1.82-2.01
1.35	A4903	A3903	100'	2.03-2.21
1.66	A4904	A3904	100'	2.63-2.87
1.81	A4905	A3905	100'	2.75-2.94
2.19	A4906	A3906	100'	3.43-3.53
2.62	A4907	A3907	100'	4.02-4.21
2.80	A4908	A3908	100'	4.43-4.62

*Package contains two pieces that are not less than 30 feet long each.

Locator Clamp

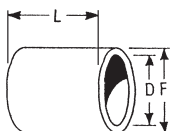

Locator Clamps are designed for crimping to H14510 or H42510 hydraulic hoses to provide a support for routing clamps. Popular for use in Case equipment applications.

Note: Crimp using collet T-400-5C and spacer ring T-400-62 (yellow), flat side up.

HOSE I.D.	CATALOG NUMBER	L	D	F
5/8	A4910	1.60	1.084	1.25

APPLICATION DATA

LOW & MEDIUM PRESSURE HOSE

HIGH PRESSURE HOSE

SPECIALTY HOSE

ACCESSORIES & ASSEMBLY INSTRUCTIONS

ADAPTERS & TUBE HOSE ENDS

HOSE ASSEMBLY EQUIPMENT

TECHNICAL DATA

Hose Sleeves and Guards

Hose Bend Restrictors



For use in protecting the last section of hose at the fitting connection, bend restrictors are designed to allow for an appropriate degree of "bend" without compromising the integrity of your hose assembly. Also recommended for hose assemblies which receive substantial handling, such as pressure washer, air, oil, and hydraulic fluid transfer applications.

Material: Plastisol MR 436
Gloss PVC

Note:

Colors RD, BU, GN, YW available by special order.

RESTRICTOR I.D.	CATALOG NUMBER	RESTRICTOR LENGTH (INCH)	HOSE TYPE APPLICATION
.530	A5953	6	H14504, H00904
.625	A5962	6	H10404, H20906, H24504, H34504, H42504
.690	A5969	6	H14506, H34506
.750	A5975	7	H10406, H20908, H24506, H30006
.840	A5984	7	H10408, H14508, H24508
.875	A5987	7	H34508

Firesleeve



Firesleeve is a flame-resistant sheathing constructed of tightly-woven fiberglass coated with a specially compounded, highly temperature-resistant, silicone rubber. Firesleeve offers you protection in hostile environments involving heat extremes. Not compatible with hydrocarbons.

Temperature Range:

Continuous exposure up to 500°F. Up to 2000°F for 15-20 minutes. Up to 3000°F for durations of 15-30 seconds.

Color: Red-Orange

Note:

Refer to application chart on pages 25-26 for locating Firesleeve part numbers for specific Weatherhead hoses.

SLEEVE I.D.	CATALOG NUMBER	ROLL LENGTH
.50	A6908	100'
.63	A6910	100'
.75	A6912	100'
.88	A6914	100'
1.00	A6916	100'
1.25	A6920	100'
1.50	A6924	100'
1.75	A6928	100'
2.00	A6932	50'
2.25	A6936	50'
2.50	A6940	50'
3.00	A6948	50'

Firesleeve Tape

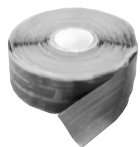

CAUTION

Tests should be made to determine the suitability of Firesleeve product for each application.

TAPE COVERAGE	CATALOG NUMBER	ROLL LENGTH (INCH)
All sizes	A6900W	1x432

Firesleeve Tape is manufactured from a high temperature-resistant, non-adhesive, silicone elastomer. It provides a self-bonding, self-curing insulator and used in conjunction with

Eaton. Firesleeve, acts as an end sealant in preventing moisture and hydraulic oils from wicking into the inner braids of Firesleeve.

Maximum Temperature:
+475° continuous.

Hose Sleeves and Guards

HOSE TYPE	DASH SIZE	HOSE CLAMP	ROUND WIRE SPRING GUARD	FLAT WIRE SPRING GUARD	NYLON (.45) ABRASION SLEEVE	NYLON (.90) ABRASION SLEEVE	SILICONE FIBERGLASS FIRESLEEVE	POLY HOSE GUARD
H009	04	HK0913	A1901	A2901	A4900	A3900	A6910	A9901
	05	HK1013	A1902	A2902	A4900	A4900	A6914	A9901
	06	HK1113	A1903	A2903	A4901	A3901	A6916	A9901
	08	HK1313	A1905	A2905	A4901	A3901	A6916	A9902
	12	HK1813	A1909	A2909	A4902	A3902	A6920	A9903
H017	04	HK1013	A1902	A2902	A4900	A3900	A6912	A9901
	06	HK1313	A1905	A2905	A4900	A3900	A6914	A9902
	08	HK1613	A1907	A2907	A4901	A3901	A6920	A9902
	12	HK2117	A1911	A2911	A4903	A3903	A6924	A9903
	16	HK2517	A1913	A2913	A4904	A3904	A6928	A9903
	20	HK2917	A1915	A2915	A4906	A3906	A6932	A9904
H039	12	HK2117	A1913	A2913	A4904	A3904	A6928	A9903
	16	HK2517	A1915	A2915	A4905	A3605	A6932	A9904
	20	HK2917	A1915	A2915	A4906	A3906	A6932	A9904
	24	HK3317	A1917	A2917	A4907	A3907	A6936	A9904
	32	HK3817	-	-	A4908	A3908	A6948	A9905
H039H	12	HK2117	A1913	A2913	A4904	A3904	A6928	A9903
	16	HK2517	A1915	A2915	A4905	A3605	A6932	A9904
	20	HK2917	A1915	A2915	A4906	A3906	A6932	A9904
	24	HK3317	A1917	A2917	A4907	A3907	A6936	A9904
	32	HK3817	-	-	A4908	A3908	A6948	A9905
H057	03	HK0709	A1900	A2900	A4900	A3900	A6910	A9900
	04	HK1013	A1901	A2901	A4900	A3900	A6912	A9901
	05	HK1013	A1902	A2902	A4900	A3900	A6914	A9901
	06	HK1113	A1903	A2903	A4900	A3900	A6914	A9901
	07	HK1213	A1904	A2904	A4901	A3901	A6916	A9902
	08	HK1313	A1905	A2905	A4901	A3901	A6916	A9902
H059	04	HK0913	A1901	A2901	A4900	A3900	A6912	A9901
	05	HK1013	A1902	A2902	A4900	A3900	A6912	A9901
	06	HK1213	A1904	A2904	A4901	A3901	A6916	A9902
	08	HK1313	A1905	A2905	A4901	A3901	A6916	A9902
	10	HK1613	A1907	A2907	A4902	A3902	A6916	A9902
	12	HK1813	A1909	A2909	A4904	A3904	A6924	A9903
	16	HK2117	A1910	A2910	A4905	A3905	A6928	A9903
H069	04	HK0913	A1901	A2901	A4900	A3900	A6912	A9901
	05	HK1013	A1905	A2905	A4900	A3900	A6912	A9901
	06	HK1213	A1905	A2905	A4901	A3901	A6912	A9902
	08	HK1413	A1905	A2905	A4901	A3901	A6916	A9902
	10	HK1613	A1907	A2907	A4902	A3902	A6916	A9902
	12	HK1913	A1909	A2909	A4903	A3903	A6920	A9903
	16	HK2117	A1910	A2910	A4904	A3904	A6924	A9903
	20	HK2517	A1913	A4913	A4906	A3906	A6928	A9903
	24	HK2117	A1916	A2916	A4907	A3907	A6932	A9904
	32	-	A1919	A2919	-	-	A6940	A9904
H077	04	HK0913	A1902	A2902	A4900	A3900	A6912	A9901
	05	HK1013	A1902	A2903	A4900	A3900	A6914	A9901
	06	HK1113	A1903	A2903	A4901	A3901	A6914	A9901
	08	HK1313	A1905	A2905	A4901	A3901	A6916	A9902
H100	04	HK0913	A1900	A2900	A4900	A3900	A6912	A9901
	05	HK1013	A1903	A2903	A4900	A3900	A6912	A9901
	06	HK1113	A1903	A2903	A4900	A3900	A6912	A9902
	08	HK1313	A1905	A2905	A4901	A3901	A6916	A9902
	10	HK1613	A1907	A2907	A4902	A3902	A6920	A9902
12	HK1813	A1908	A2908	A4903	A3903	A6924	A9903	

APPLICATION DATA
 LOW & MEDIUM PRESSURE HOSE
 HIGH PRESSURE HOSE
 SPECIALTY HOSE
 ACCESSORIES & ASSEMBLY INSTRUCTIONS
 ADAPTERS & TUBE HOSE ENDS
 HOSE ASSEMBLY EQUIPMENT
 TECHNICAL DATA

Hose Sleeves and Guards

APPLICATION DATA

LOW & MEDIUM PRESSURE HOSE

HIGH PRESSURE HOSE

SPECIALTY HOSE

ACCESSORIES & ASSEMBLY INSTRUCTIONS

ADAPTERS & HOSE ENDS

HOSE ASSEMBLY EQUIPMENT

TECHNICAL DATA

HOSE TYPE	DASH SIZE	HOSE CLAMP	ROUND WIRE SPRING GUARD	FLAT WIRE SPRING GUARD	NYLON (.45) ABRASION SLEEVE	NYLON (.90) ABRASION SLEEVE	SILICONE FIBERGLASS FIBRESLEEVE	POLY HOSE GUARD
H101	04	HK0913	A1902	A2902	A4900	A3900	A6910	A9901
	05	HK1013	A1903	A2903	A4900	A3900	A6912	A9901
	06	HK1113	A1903	A2903	A4900	A3900	A6912	A9901
	08	HK1413	A1905	A2905	A4902	A3902	A6916	A9902
	10	HK1613	A1907	A2907	A4903	A3903	A6920	A9902
	12	HK1813	A1908	A2908	A4903	A3903	A6924	A9903
H104	04	HK1903	A1902	A2902	A4900	A3900	A6912	A9901
	06	HK1213	A1904	A2904	A4900	A3900	A6914	A9902
	08	HK1413	A1907	A2907	A4902	A3902	A6920	A9902
	10	HK1613	A1907	A2907	A4903	A3903	A6924	A9902
	12	HK1913	A1910	A2910	A4903	A3903	A6924	A9903
	16	HK2317	A1913	A2913	A4904	A3904	A6928	A9903
	20	HK2117	A1916	A2916	A4906	A3906	A6936	A9904
H105	04	HK1113	A1903	A2903	A4900	A3900	A6914	A9901
	06	HK1313	A1905	A2905	A4903	A3903	A6914	A9902
	08	HK1513	A1907	A2907	A4904	A3904	A6924	A9902
	12	HK2017	A1910	A2910	A4904	A3904	A6924	A9903
	16	HK2517	A1913	A2913	A4906	A3906	A6932	A9903
H114	04	HK0913	A1902	A2902	A4900	A3900	A6912	A9901
	06	HK1113	A1904	A2904	A4900	A3900	A6914	A9901
	08	HK1413	A1906	A2906	A4902	A3902	A6920	A9902
H115	04	HK1113	A1902	A2902	A4900	A3900	A6912	A9901
	05	HK1113	A1904	A2904	A4900	A3900	A6912	A9901
	06	HK1213	A1904	A2904	A4900	A3900	A6914	A9902
	08	HK1513	A1907	A2907	A4901	A3901	A6920	A9902
	12	HK2017	A1910	A2910	A4903	A3903	A6924	A9903
	16	HK2317	A1913	A2913	A4904	A3904	A6928	A9903
	20	HK2117	A1916	A2916	A4906	A3906	A6936	A9904
	24	HK3317	A1917	A2917	A4907	A3907	A6940	A9904
H145	04	HK0913	A1900	A2900	A4900	A3900	A6912	A9900
	06	HK1113	A1904	A2904	A4901	A3901	A6916	A9901
	08	HK1413	A1906	A2906	A4901	A3901	A6916	A9902
	10	HK1613	A1908	A2908	A4903	A4903	A6924	A9902
	12	HK1813	A1910	A2910	A4903	A3903	A6924	A9902
	16	HK2317	A1913	A2913	A4904	A3904	A6928	A9903
H145R	04	HK0913	A1900	A2900	A4900	A3900	A6912	A9900
	06	HK1113	A1904	A2904	A4901	A3901	A6916	A9901
	08	HK1413	A1906	A2906	A4901	A3901	A6916	A9902
	10	HK1613	A1908	A2908	A4903	A4903	A6924	A9902
	12	HK1813	A1910	A2910	A4903	A3903	A6924	A9902
	16	HK2317	A1913	A2913	A4904	A3904	A6928	A9903
H146	04	HK0913	A1902	A2902	A4900	A3900	A6912	A9901
	06	HK1213	A1905	A2905	A4901	A3901	A6914	A9902
	08	HK1413	A1906	A2906	A4901	A3901	A6920	A9903
H166	04	HK0913	A1900	A2900	A4900	A3900	A6912	A9901
	05	HK1013	A1902	A2902	A4900	A3900	A6912	A9901
	06	HK1013	A1904	A2904	A4901	A3901	A6916	A9902
	08	HK1413	A1905	A2905	A4901	A3901	A6916	A9902
	10	HK1613	A1907	A2907	A4901	A3901	A6920	A9902
	12	HK1913	A1910	A2910	A4903	A3903	A6924	A9903
	16	HK2117	A1911	A2911	A4905	A3905	A6932	A9903
	20	HK2517	A1913	A2913	A4905	A3905	A6940	A9903

Hose Sleeves and Guards

HOSE TYPE	DASH SIZE	HOSE CLAMP	ROUND WIRE SPRING GUARD	FLAT WIRE SPRING GUARD	NYLON (.45) ABRASION SLEEVE	NYLON (.90) ABRASION SLEEVE	SILICONE FIBERGLASS FIRESLEEVE	POLY HOSE GUARD
H169	04	HK1013	A1901	A2901	A4900	A3900	A6914	A9901
	05	HK1113	A1902	A2902	A4900	A3900	A6914	A9901
	06	HK1213	A1904	A2904	A4901	A3901	A6916	A9902
	08	HK1413	A1905	A2905	A4901	A3901	A6916	A9902
	10	HK1613	A1907	A2907	A4901	A3901	A6920	A9902
	12	HK1913	A1910	A2910	A4903	A3903	A6924	A9903
	16	HK2117	A1912	A2912	A4905	A3905	A6932	A9903
	20	HK2517	A1913	A2913	A4904	A3904	A6940	A9903
	24	HK2917	A1916	A2916	A4907	A3907	A6948	A9904
	32	HK3417	A1919	A2919	-	-	-	A9904
H190	04	HK1013	A1902	A2902	A4900	A3900	A6914	A9901
	06	HK1213	A1904	A2904	A4901	A3901	A6916	A9902
	08	HK1413	A1906	A2906	A4901	A3901	A6916	A9902
	10	HK1613	A1908	A2908	A4901	A3901	A6920	A9902
	12	HK1913	A1910	A2910	A4903	A3903	A6924	A9903
	16	HK2517	A1913	A2913	A4905	A3905	A6932	A9903
H190H	04	HK1013	A1902	A2902	A4900	A3900	A6914	A9901
	06	HK1213	A1904	A2904	A4901	A3901	A6916	A9902
	08	HK1413	A1906	A2906	A4901	A3901	A6916	A9902
	10	HK1613	A1908	A2908	A4901	A3901	A6920	A9902
	12	HK1913	A1910	A2910	A4903	A3903	A6924	A9903
	16	HK2517	A1913	A2913	A4905	A3905	A6932	A9903
H201	04	HK0913	A1901	A2901	A4900	A3900	A3612	A9901
	06	HK1113	A1903	A2903	A4901	A3901	A6914	A9901
	08	HK1313	A1905	A2905	A4901	A3901	A6916	A9902
	10	HK1613	A1907	A2907	A4902	A3902	A6920	A9902
	12	HK1813	A1908	A2908	A4903	A3903	A6924	A9903
H209	04	HK0809	A1900	A2900	A4900	A3900	A6910	A9900
	05	HK0913	A1902	A2902	A4900	A3900	A6914	A9900
	06	HK1013	A1903	A2903	A4901	A3901	A6914	A9900
	08	HK1213	A1905	A2905	A4901	A3901	A6920	A9902
H213	04	HK0913	A1901	A2901	A4900	A3900	A6910	A9900
	05	HK1013	A1902	A2902	A4900	A3900	A6914	A9900
	06	HK1113	A1903	A2903	A4900	A3900	A6914	A9901
	08	HK1313	A1905	A2905	A4901	A3901	A6920	A9902
	10	HK1413	A1907	A2907	A4902	A3902	A6920	A9902
	12	HK1713	A1908	A2908	A4903	A3903	A6924	A9902
	16	HK2017	A1911	A2911	A4904	A3904	A6928	A9903
H229	04	HK0913	A1901	A2901	A4900	A3900	A6910	A9901
	06	HK1213	A1904	A2904	A4901	A3901	A6914	A9902
	08	HK1413	A1905	A2905	A4902	A3902	A6924	A9902
	10	HK1613	A1907	A2907	A4902	A3902	A6924	A9902
H229	12	HK2617	A1912	A2912	A4905	A3905	A6928	A9903
	16	HK2117	A1912	A2912	A4906	A3906	A6932	A9906
H239	04	HK0913	A1901	A2901	A4900	A3900	A6912	A9901
	08	HK1313	A1905	A2905	A4901	A3901	A6920	A9902
	10	HK1613	A1907	A2907	A4902	A3902	A6920	A9902
	12	HK1813	A1910	A2910	A4905	A3905	A6928	A9903
	16	HK2117	A1912	A2912	A4906	A3906	A6932	A9903
	20	HK2517	A1913	A2913	A4904	A3904	A6940	A9903

APPLICATION DATA

LOW & MEDIUM PRESSURE HOSE

HIGH PRESSURE HOSE

SPECIALTY HOSE

ACCESSORIES & ASSEMBLY INSTRUCTIONS

ADAPTERS & TUBE HOSE ENDS

HOSE ASSEMBLY EQUIPMENT

TECHNICAL DATA

Hose Sleeves and Guards

HOSE TYPE	DASH SIZE	HOSE CLAMP	ROUND WIRE SPRING GUARD	FLAT WIRE SPRING GUARD	NYLON (.45) ABRASION SLEEVE	NYLON (.90) ABRASION SLEEVE	SILICONE FIBERGLASS FIBRESLEEVE	POLY HOSE GUARD	
H243	03	HK0709	A1900	A2900	A4900	A3900	A6910	A9900	
	04	HK0709	A1900	A2900	A4900	A3900	A6914	A9900	
	05	HK0809	A1902	A2902	A4900	A3900	A6914	A9901	
	06	HK0913	A1903	A2903	A4901	A3901	A6920	A9901	
	08	HK1113	A1905	A2905	A4902	A3902	A6920	A9902	
	12	HK1513	A1909	A2909	A4904	A3904	A6924	A9903	
	16	HK1913	A1911	A2911	A4905	A3905	A6928	A9904	
H245	04	HK1013	A1902	A2902	A4900	A3900	A6914	A9901	
	06	HK1013	A1904	A2904	A4903	A3903	A6920	A9902	
	08	HK1213	A1906	A2906	A4904	A3904	A6924	A9902	
	10	HK1413	A1907	A2907	A4904	A3904	A6924	A9902	
	12	HK1613	A1910	A2910	A4905	A3905	A6928	A9903	
	16	HK2317	A1913	A2913	A4906	A3906	A6932	A9903	
	20	HK2917	A1916	A2916	A4907	A3907	A6940	A9904	
H265	04	HK0913	A1902	A2902	A4900	A3900	A6914	A9901	
	06	HK1213	A1904	A2904	A4901	A3901	A6916	A9901	
	08	HK1413	A1905	A2905	A4902	A3902	A6920	A9902	
	12	HK1813	A1910	A2910	A4904	A3904	A6928	A9903	
	16	HK2217	A1913	A2913	A4905	A3905	A6932	A9903	
	H275	03	HK0809	A1900	A2900	A4900	A3900	A6912	A9900
		04	HK0913	A1902	A2902	A4900	A3900	A6914	A9901
06		HK1113	A1903	A2903	A4901	A3901	A6916	A9901	
08		HK1413	A1905	A2905	A4902	A3902	A6920	A9902	
12		HK1813	A1907	A2907	A4904	A3904	A6924	A9902	
16		HK2217	A1913	A2913	A4905	A3905	A6928	A9903	
20		HK2917	A1916	A2916	A4907	A3907	A6936	A9904	
H277	03	HK0709	A1900	A2900	A4900	A3900	A6910	A9900	
	04	HK0709	A1900	A2900	A4900	A3900	A6914	A9900	
	05	HK0809	A1900	A2900	A4901	A3901	A6920	A9902	
	06	HK0913	A1903	A2903	A4902	A3902	A6920	A9902	
	08	HK1113	A1903	A2903	A4901	A3901	A6920	A9902	
	12	HK1513	A1907	A2907	A4904	A3904	A6928	A9903	
	16	HK1913	A1910	A2910	A4905	A3905	A6932	A9903	
H280	04	HK1013	A1901	A2901	A4900	A3900	A6914	A9901	
	06	HK1213	A1904	A2904	A4901	A3901	A6920	A9902	
	08	HK1413	A1906	A2906	A4901	A3901	A6920	A9902	
	10	HK1613	A1907	A2907	A4904	A3904	A6928	A9903	
	12	HK1913	A1910	A2910	A4904	A3904	A6928	A9903	
	16	HK2517	A1913	A2913	A4905	A3905	A6932	A9903	
	H285	04	HK0913	A1900	A2900	A4900	A3900	A6914	A9900
06		HK1213	A1903	A2903	A4901	A3901	A6916	A9901	
08		HK1413	A1905	A2905	A4901	A3901	A6920	A9902	
12		HK1813	A1910	A2910	A4904	A3904	A6924	A9903	
16		HK2217	A1912	A2912	A4905	A3905	A6928	A9903	
H290	04	HK1113	A1903	A2903	A4900	A3900	A6914	A9901	
	06	HK1313	A1905	A2905	A4901	A3901	A6916	A9902	
	08	HK1513	A1907	A2907	A4902	A3902	A6920	A9902	
	10	HK1713	A1909	A2909	A4904	A3904	A6924	A9903	
	12	HK2017	A1910	A2910	A4904	A3904	A6928	A9903	
16	HK2517	A1913	A2913	A4904	A3904	A6932	A9903		

LOW & MEDIUM
PRESSURE HOSE

HIGH PRESSURE HOSE

SPECIALTY HOSE

ACCESSORIES &
ASSEMBLY INSTRUCTIONSADAPTERS &
HOSE ENDSHOSE ASSEMBLY
EQUIPMENT

TECHNICAL DATA

Hose Sleeves and Guards

HOSE TYPE	DASH SIZE	HOSE CLAMP	ROUND WIRE SPRING GUARD	FLAT WIRE SPRING GUARD	NYLON (.45) ABRASION SLEEVE	NYLON (.90) ABRASION SLEEVE	SILICONE FIBERGLASS FIRESLEEVE	POLY HOSE GUARD
H290H	04	HK1113	A1903	A2903	A4900	A3900	A6914	A9901
	06	HK1313	A1905	A2905	A4901	A3901	A6916	A9902
	08	HK1513	A1907	A2907	A4902	A3902	A6920	A9902
	10	HK1713	A1909	A2909	A4904	A3904	A6924	A9903
	12	HK2017	A1910	A2910	A4904	A3904	A6928	A9903
	16	HK2517	A1913	A2913	A4904	A3904	A6932	A9903
H324	06	HK1313	A1905	A2905	A4900	A3900	A6924	A9902
H325	04	HK1013	A1903	A2903	A4900	A3900	A6914	A9901
	06	HK1313	A1905	A2905	A4900	A3900	A3616	A9902
	08	HK1513	A1907	A2907	A4901	A3901	A6920	A9902
	12	HK2017	A1910	A2910	A4904	A3904	A6928	A9903
	16	HK2517	A1913	A4913	A4904	A3904	A3932	A9903
H332	04	HK1013	A1903	A2903	A4900	A3900	A6914	A9901
	06	HK1313	A1905	A2905	A4900	A3900	A3616	A9902
	08	HK1513	A1907	A2907	A4901	A3901	A6920	A9902
	12	HK2017	A1910	A2910	A4904	A3904	A6928	A9903
	16	HK2517	A1913	A4913	A4904	A3904	A3932	A9903
H335	03	HK0913	A1901	A2901	A4900	A3900	A6916	A9901
	04	HK1113	A1903	A2903	A4901	A3901	A6916	A9902
	06	HK1313	A1904	A2904	A4902	A3902	A6920	A9902
	08	HK1513	A1907	A2907	A4902	A3902	A6924	A9902
	12	HK1913	A1910	A2910	A4903	A3903	A6924	A9903
	16	HK2517	A1913	A2913	A4905	A3905	A6928	A6603
H336	03	HK0913	A1901	A2901	A4900	A3900	A6916	A9901
	04	HK1113	A1903	A2903	A4901	A3901	A6916	A9902
	06	HK1313	A1904	A2904	A4902	A3902	A6920	A9902
	08	HK1513	A1907	A2907	A4902	A3902	A6924	A9903
	12	HK1913	A1910	A2910	A4903	A3903	A6924	A9903
	16	HK2517	A1913	A2913	A4905	A3905	A6928	A9902
H338	06	HK1313	A1905	A2905	A4900	A3900	A6920	A9902
	08	HK1513	A1907	A2907	A4901	A3901	A6920	A9902
H342	04	HK1013	A1900	A2900	A4900	A3900	A6910	A9901
	06	HK1213	A1904	A2904	A4900	A3900	A6912	A9901
	08	HK1513	A1905	A2905	A4900	A3900	A6914	A9902
	10	HK1813	A1908	A2908	A4901	A3901	A6920	A9902
	12	HK2017	A1910	A2910	A4902	A3902	A6920	A9903
	16	HK2617	A1913	A2913	A4904	A3904	A6928	A9903
H345	04	HK0913	A1900	A2900	A4900	A3900	A6916	A9901
	06	HK1113	A1904	A2904	A4900	A3900	A6920	A9902
	08	HK1313	A1905	A2905	A4901	A3901	A6924	A9902
H350	06	HK1313	A1904	A2904	A4901	A3901	A6916	A9902
	08	HK1513	A1906	A2906	A4901	A3901	A6916	A9902
	10	HK1813	A1908	A2908	A4904	A3904	A6924	A9903
	12	HK2017	A1910	A2910	A4905	A3905	A6928	A9903
	16	HK2517	A1913	A4913	A4906	A3906	A6936	A9903
H366	06	HK1213	A1904	A2904	A4901	A3901	A6916	A9902
	08	HK1413	A1905	A2905	A4901	A3901	A6916	A9902
H400	10	HK1713	A1909	A2909	A4903	A3903	A6920	A9903

APPLICATION DATA

LOW & MEDIUM PRESSURE HOSE

HIGH PRESSURE HOSE

SPECIALTY HOSE

ACCESSORIES & ASSEMBLY INSTRUCTIONS

ADAPTERS & TUBE HOSE ENDS

HOSE ASSEMBLY EQUIPMENT

TECHNICAL DATA

Hose Sleeves and Guards

HOSE TYPE	DASH SIZE	HOSE CLAMP	ROUND WIRE SPRING GUARD	FLAT WIRE SPRING GUARD	NYLON (.45) ABRASION SLEEVE	NYLON (.90) ABRASION SLEEVE	SILICONE FIBERGLASS FIRESLEEVE	POLY HOSE GUARD
H425	04	HK1113	A1903	A2903	A4900	A3900	A6916	A9902
	06	HK1313	A1905	A2905	A4900	A3900	A6916	A9902
	08	HK1513	A1907	A2907	A4902	A3902	A6920	A9902
	10	HK1713	A1909	A2909	A4903	A3903	A6920	A9903
	12	HK2017	A1911	A2911	A4903	A3903	A6924	A9903
	16	HK2517	A1913	A2913	A4905	A3905	A6928	A9903
	20	HK3117	A1916	A2916	A4906	A3906	A6936	A9904
	24	HK3417	A1919	A2919	A4907	A3907	A6940	A9904
	32	HK3817	-	-	-	-	-	A9905
H430	08	HK1613	A1908	A2908	A4904	A3904	A6924	A9903
	12	HK2117	A1912	A2912	A4905	A3905	A6928	A9903
	16	HK2517	A1913	A2913	A4906	A3906	A6936	A9903
	20	HK3117	A1916	A2916	A4907	A3907	A6940	A9904
	24	-	A1919	A2919	A4907	A3907	A6940	A9904
	32	HK3817	-	-	-	-	-	A9905
H430R	08	HK1613	A1908	A2908	A4904	A3904	A6924	A9903
	12	HK2117	A1912	A2912	A4905	A3905	A6928	A9903
	16	HK2517	A1913	A2913	A4906	A3906	A6936	A9903
	20	HK3117	A1916	A2916	A4907	A3907	A6940	A9904
	24	-	A1919	A2919	A4907	A3907	A6940	A9904
	32	HK3817	-	-	-	-	-	A9905
H435	04	HK0809	A1900	A2900	A4900	A3900	A6912	A9901
	05	HK1013	A1903	A2903	A4900	A3900	A6912	A9901
	06	HK1113	A1904	A2904	A4900	A3900	A6916	A9901
	08	HK1413	A1906	A2906	A4902	A3902	A6920	A9902
	12	HK1813	A1910	A2910	A4903	A3903	A6924	A9903
	16	HK2317	A1913	A2913	A4904	A3904	A6928	A9903
	20	HK3117	A1916	A2916	A4907	A3907	A6940	A9904
H436	04	HK0809	A1900	A2900	A4900	A3900	A6912	A9901
	05	HK1013	A1903	A2903	A4900	A3900	A6912	A9901
	06	HK1113	A1904	A2904	A4901	A3901	A6916	A9901
	08	HK1413	A1906	A2906	A4902	A3902	A6920	A9902
	12	HK1813	A1910	A2910	A4903	A3903	A6924	A9903
	16	HK2317	A1913	A2913	A4904	A3904	A6928	A9903
	20	HK3117	A1916	A2916	A4907	A3907	A6940	A9904
H461	08	HK1713	A1907	A2907	A4901	A3901	A6916	A9902
	12	HK2117	A1910	A2910	A4903	A3903	A6920	A9903
	16	HK2617	A1913	A2913	A4904	A3904	A6928	A9903
	20	HK3217	A1916	A2917	A4906	A3906	A6932	A9904
	24	HK3417	A1919	A1919	A4906	A3906	A6936	A9904
	32	HK3817	-	-	A4908	A3908	A6948	A9905
H464	12	HK2217	-	-	A4903	A3903	A6920	A9902
	16	HK2517	-	-	A4904	A3904	A6924	A9902
	20	HK3117	-	-	A4905	A3905	A6928	A9903
	24	HK3417	-	-	A4906	A3906	A6936	A9903
	32	HK3817	-	-	A4908	A3908	A6948	A9904
H470	08	HK1713	A1908	A2908	A4901	A3901	A6916	A9902
	12	HK2117	A1911	A2911	A4904	A3904	A6928	A9903
	16	HK2517	A1913	A2913	A4904	A3904	A6928	A9903
	20	HK3217	A1917	A2917	A4906	A3906	A6936	A9904
	24	HK3417	A1919	A2919	A4907	A3907	A6940	A9904
	32	HK3817	-	-	-	-	-	A9905

LOW & MEDIUM
PRESSURE HOSE

HIGH PRESSURE HOSE

SPECIALTY HOSE

ACCESSORIES &
ASSEMBLY INSTRUCTIONSADAPTERS &
HOSE ENDSHOSE ASSEMBLY
EQUIPMENT

TECHNICAL DATA

Hose Sleeves and Guards

HOSE TYPE	DASH SIZE	HOSE CLAMP	ROUND WIRE SPRING GUARD	FLAT WIRE SPRING GUARD	NYLON (.45) ABRASION SLEEVE	NYLON (.90) ABRASION SLEEVE	SILICONE FIBERGLASS FIRESLEEVE	POLY HOSE GUARD
H545	04	HK1013	A1902	A2902	A4900	A3900	A6912	A9901
	06	HK1213	A1904	A2904	A4901	A3901	A6916	A9901
	08	HK1513	A1906	A2906	A4901	A3901	A6916	A9902
	10	HK1713	A1907	A2907	A4903	A3903	A6924	A9902
	12	HK2017	A1910	A2910	A4904	A3904	A6928	A9903
	16	HK2517	A1913	A2913	A4906	A3906	A6936	A9903
H569	04	HK0913	A1901	A2901	A4900	A3900	A6912	A9901
	05	HK1113	A1902	A2902	A4900	A3900	A6912	A9901
	06	HK1213	A1904	A2904	A4901	A3901	A6916	A9902
	08	HK1413	A1905	A2905	A4901	A3901	A6916	A9902
	10	HK1613	A1907	A2907	A4901	A3901	A6916	A9902
	12	HK1913	A1910	A2910	A4903	A3903	A6924	A9903
	16	HK2117	A1911	A2911	A4904	A3904	A6928	A9903
	20	HK2517	A1913	A2913	A4906	A3906	A6936	A9903
H757	06	HK1013	A1902	A2902	A4900	A3900	A6916	A9901
	08	HK1213	A1904	A2904	A4900	A3900	A6920	A9902
	10	HK1313	A1905	A2905	A4901	A3901	A6920	A9902
	12	HK1613	A1907	A2907	A4902	A3902	A6924	A9902
	14	HK1913	A1910	A2910	A4903	A3903	A6924	A9903

APPLICATION DATA

LOW & MEDIUM PRESSURE HOSE

HIGH PRESSURE HOSE

SPECIALTY HOSE

ACCESSORIES & ASSEMBLY INSTRUCTIONS

ADAPTERS & TUBE HOSE ENDS

HOSE ASSEMBLY EQUIPMENT

TECHNICAL DATA

Polycoil Brass Hose Products

H130 Coiled Hose Polycoil Hose

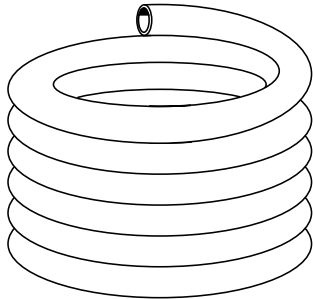

HOSE I.D.	HOSE O.D.	CATALOG NUMBER	RECOM. OPER. PRESS. 76°F	MIN. BURST PRESSURE	RETRACTED LENGTH
1/4	.316	H13004-100	200	800	39-1/4
3/8	.465	H13006-100	200	800	34-1/2

⚠ CAUTION

Product should not be used in applications where temperature exceeds 200° F. Exceeding temperature level could result in hose rupture.

Hose Construction:
Nylon 12 extruded.

Color: Yellow

Temperature: -40°F to +200°F (-40°C to +93°C)

Application:
All types of air tools.

Working Length:
For 100' of Polycoil is 94'.

- Easy to clean.

- Self-retracting.
- Lightweight.
- Easy to handle.
- Out of the way when not in use.
- Eliminates need for reels and other expensive take-up devices.
- May also be ordered as ready-made hose assemblies. See below.

Polycoil Assemblies

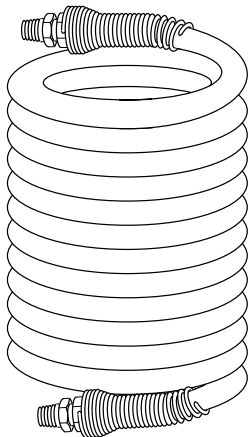

NOMINAL HOSE I.D.	MAXIMUM WORKING LENGTH	MALE PIPE RIGID	MALE PIPE SWIVEL	CATALOG NUMBER	NOMINAL COIL O.D.
1/4"	10.5'	—	1/4"	13004JJ-12†	3-1/2"
1/4"	10.5'	1/4"	1/4"	130041J-12	3-1/2"
1/4"	10.5'	1/4"	—	1300411-12*	3-1/2"
1/4"	23.5'	—	1/4"	13004JJ-25†	3-1/2"
1/4"	23.5'	1/4"	1/4"	130041J-25	3-1/2"
1/4"	23.5'	1/4"	—	1300411-25*	3-1/2"
1/4"	47'	—	1/4"	13004JJ-50†	3-1/2"
1/4"	47'	1/4"	1/4"	130041J-50	3-1/2"
1/4"	47'	1/4"	—	1300411-50*	3-1/2"
3/8"	10.5'	—	3/8"	13006JJ-12†	5-3/4"
3/8"	10.5'	3/8"	3/8"	130061J-12	5-3/4"
3/8"	10.5'	3/8"	—	1300611-12*	5-3/4"
3/8"	23.5'	—	3/8"	13006JJ-25†	5-3/4"
3/8"	23.5'	3/8"	3/8"	130061J-25	5-3/4"
3/8"	23.5'	3/8"	—	1300611-25*	5-3/4"
3/8"	47'	—	3/8"	13006JJ-50†	5-3/4"
3/8"	47'	3/8"	3/8"	130061J-50	5-3/4"
3/8"	47'	3/8"	—	1300611-50*	5-3/4"

†Male pipe swivel on both ends.

*Male pipe rigid on both ends.

13000 Series Brass Hose Ends



Typical Application: Shop air with pneumatic air tools.

Material: CA360 Brass.

Used With: H130 Hose.

Advantages: Self-storing, compact and low cost.

⚠ CAUTION:
Overtightening may be detrimental to the connection.

Polycoil Brass Hose Products

Polycoil Assembly Instructions

1. Assemble onto hose in this order:
 - a. Spring guard
 - b. Nut and sleeve
 - c. End fitting—make sure hose is bottomed
2. Tighten nut and sleeve onto fitting—finger tight
3. Tighten nut onto fitting 1-1/2 additional turns
4. Assemble spring guard over nut

Sleeve (Plastic)

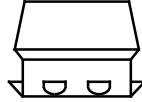

HOSE I.D.	CATALOG NUMBER
1/4	13004-A
3/8	13006-A

Nut (Brass)

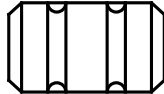

HOSE I.D.	CATALOG NUMBER
1/4	13004-B
3/8	13006-B

Spring Guard (Steel)



HOSE I.D.	CATALOG NUMBER
1/4	13004-C
3/8	13006-C

Male Pipe Rigid (Brass)

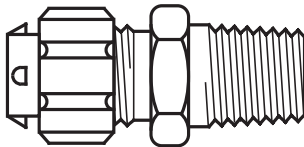

HOSE I.D.	MALE PIPE SIZE	CATALOG NUMBER
1/4	1/4	13004-1
3/8	3/8	13006-1

Male Pipe Swivel (Brass)

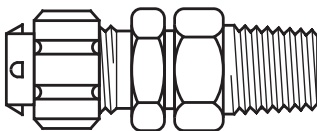

HOSE I.D.	MALE PIPE SIZE	CATALOG NUMBER
1/4	1/4	13004-J
3/8	3/8	13006-J

APPLICATION DATA

LOW & MEDIUM PRESSURE HOSE

HIGH PRESSURE HOSE

SPECIALTY HOSE

ACCESSORIES & ASSEMBLY INSTRUCTIONS

ADAPTERS & TUBE HOSE ENDS

HOSE ASSEMBLY EQUIPMENT

TECHNICAL DATA

Ready-Made Hose Assemblies

Air Compressor Discharge PTFE Hose Assembly

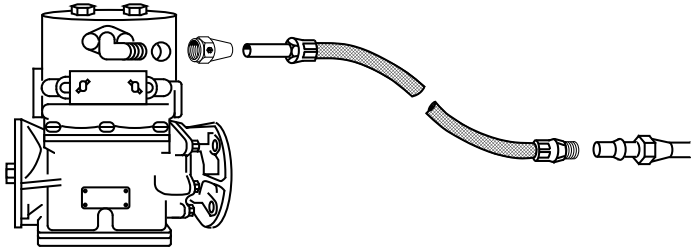

Replace troublesome copper tubing running from the air compressor discharge to the reservoir with ready-made PTFE assemblies. Hoses of PTFE assemblies eliminate tubing failures caused by vibration and heat. And they are easy to install with standard air brake nuts and sleeves. No special fittings or adapters needed.

Max. Working Pressure:
1000 PSI

Temperature Range:
-65°F to +450°F
(-18°C to +232°C)

Standpipe to Male Air Brake



Standpipe to Standpipe



SAE 45° Flare to SAE 45° Flare



	LENGTH	CATALOG NUMBER
1/2" hose I.D. - 1/2" tube size	24"	WTY824
	30"	WTY830
	36"	WTY836
	48"	WTY848
5/8" hose I.D. - 5/8" tube size	24"	WTY024
	30"	WTY030
	36"	WTY036
	48"	WTY048
5/8" hose I.D. - 3/4" tube size	24"	WTY224
	30"	WTY230
	36"	WTY236
	48"	WTY248

	LENGTH	CATALOG NUMBER
1/2" hose I.D. - 1/2" tube size	24"	WTT824
	36"	WTT836
5/8" hose I.D. - 5/8" tube size	24"	WTT024
	36"	WTT036
5/8" hose I.D. - 3/4" tube size	24"	WTT224
	36"	WTT236

	LENGTH	CATALOG NUMBER
1/2" hose I.D. - 5/8" tube size	34"	W44034
	38"	W44038
	40"	W44040
	42"	W44042
	48"	W44048
	50"	W44050
	52"	W44052
5/8" hose I.D. - 3/4" tube size	54"	W44054
	67"	W44067
	35"	W44235
	39"	W44239
	52"	W44252

Ready-Made Hose Assemblies

Air Compressor Discharge PTFE Hose Assembly for GM Buses

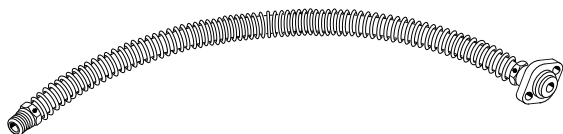

Fuel Line Hose Assembly

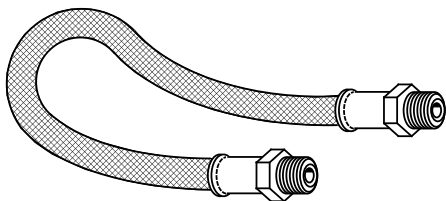

Coiled Air Brake Tube Assemblies

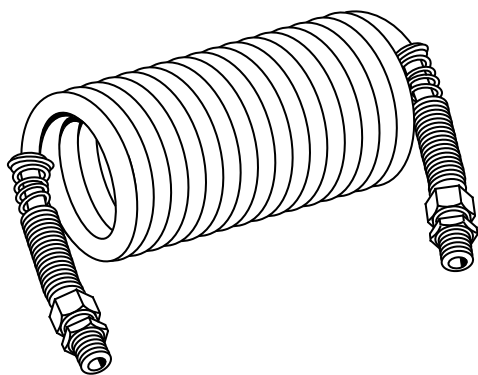

	OVERALL LENGTH	CATALOG NUMBER	REPLACES GM NUMBER
3/4" male pipe to flange	27-5/8"	W67157	2267157

CATALOG NUMBER	INVERTED FLARE
11100	5/16"

11100 preformed fuel line assembly fits all Ford Escort and Mercury Lynx cars through 1986. 5/16" inverted flare swivel hose ends, steel braided cover. Replaces OEM part number E1FZ9327-F.

Air compressor discharge hose assemblies can also be made using Weatherhead's H243 hose and 'E' Series hose ends with the Coll-O-Crimp field crimping system.

CATALOG NUMBER	TUBE O.D.	MALE PIPE	WORKING LENGTH	PIGTAIL LENGTH
W1206*	1/2"	1/2"	12'	6"
W1212*	1/2"	1/2"	12'	12"
W1212-1R	1/2"	1/2"	12'	12"
W1212-1B	1/2"	1/2"	12'	12"
W1512*	1/2"	1/2"	15'	12"
W1512-1R	1/2"	1/2"	15'	12"
W1512-1B	1/2"	1/2"	15'	12"

* Each catalog number contains a coiled red assembly and a coiled blue assembly.

Conforms to SAE J844 Type B and SAE J1131.
Conforms to DOT FMVSS 571.106.
Brass end fittings with spring guards and 1/2" male pipe connections.
Spring guards zinc plated for maximum corrosion resistance.

Preassembled for immediate installation.
Maximum Working Pressure: 150 PSI.
Minimum Burst: 950 PSI.
Temperature Range: -40°F to +200°F (-40°C to +93°C).
Color Coding: Red for emergency and blue for service.

Ready-Made Hose Assemblies

Grease Hose Whip Ends for High Pressure Grease Applications

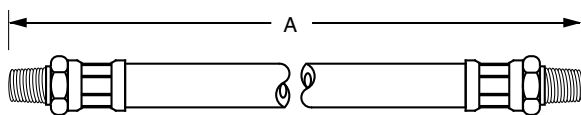

CATALOG NUMBER	PIPE THREAD	HOSE I.D.	A	HOSE MATERIAL
11312	1/8-27	3/16"	12"	Rubber
11318	1/8-27	3/16"	18"	Rubber
11352	1/8-27	3/16"	12"	Nylon
11358	1/8-27	3/16"	18"	Nylon

Max. Working Pressure:
3000 PSI

Temperature Range: -40°F
to +200°F (-40°C to +93°C)

Note:
Use with hand operated grease gun only!

Power Trim Hose Assembly

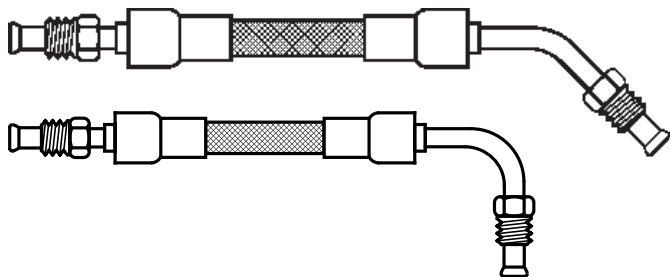

CATALOG NUMBER	OVERALL LENGTH	FITTING DESCRIPTION
1909	14-1/2"	3/16" Inv. Nut Straight x 3/16" Inv. Nut 90° Elbow
1910	14-1/2"	3/16" Inv. Nut Straight x 3/16" Inv. Nut 45° Elbow

Expand your service to marinas with the new Inboard/Outboard Power Trim PTFE Hose assemblies from Weatherhead. These hose assemblies offer a working pressure of 3000 PSI and temperature range of -65°F to +450°F.

It is available in the most popular size, 3/16" I.D., 14-1/2" long, with inverted nut end styles. You also get the non-aging and temperature resistant qualities of PTFE plus the corrosion resistance of 300 Series stainless steel fittings and braid.

Gladhand Couplings

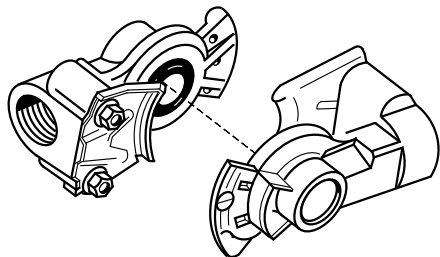

	CATALOG NUMBER
SERVICE (Signal) (Connects only to service)	W79850
EMERGENCY (Supply line) (Connects only to emergency)	W79851
UNIVERSAL (Connects to all three styles)	W76150
GLADHAND SEAL	W14630**

** For use with W79850, W79851, and W76150 Gladhands.

- Die cast aluminum body
- Conforms to SAE J318
- Connects to 1/2" pipe

Ready-Made Hose Assemblies

Air Brake Air Chamber Hose Lines

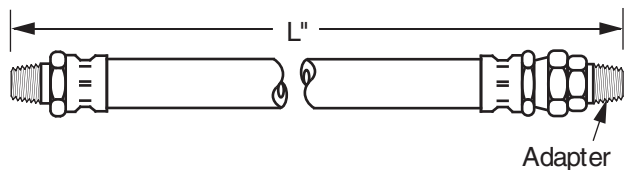

- Low cost
- Ready to install
- Available in both 3/8" and 1/2" I.D.

Air Brake Air Chamber Hose Lines

HOSE ASSY. I.D.	MALE PIPE	AIR BRAKE SWIVEL**	LENGTH L (INCHES)	FACTORY MADE CATALOG NUMBER*	PREVIOUS CATALOG NUMBER
1/2"	3/8"	3/8"	15"	38353-01500	
1/2"	3/8"	3/8"	16"	38353-01600	
1/2"	3/8"	3/8"	18"	38353-01800	W86471
1/2"	3/8"	3/8"	19"	38353-01900	
1/2"	3/8"	3/8"	20-3/8"	38353-02037	W86539
1/2"	3/8"	3/8"	22"	38353-02200	
1/2"	3/8"	3/8"	23"	38353-02300	
1/2"	3/8"	3/8"	24"	38353-02400	W86472
1/2"	3/8"	3/8"	26"	38353-02600	
1/2"	3/8"	3/8"	28-3/8"	38353-02837	W86473
1/2"	3/8"	3/8"	30"	38353-03000	W86550
1/2"	3/8"	3/8"	32"	38353-03200	W86552
1/2"	3/8"	3/8"	34-3/8"	38353-03437	W86554
1/2"	3/8"	3/8"	36"	38353-03600	W86555
1/2"	3/8"	3/8"	41-1/8"	38353-04112	W86559
1/2"	3/8"	3/8"	44"	38353-04400	
1/2"	3/8"	3/8"	46"	38353-04600	
1/2"	3/8"	3/8"	48"	38353-04800	
1/2"	3/8"	3/8"	60"	38353-06000	
1/2"	3/8"	3/8"	72"	38353-07200	

Air chamber hose assemblies can also be made using Weatherhead's H338 hose, 33808P-106 and 33808P-Y76 hose ends, and 1390x6x6 adapter with the Coll-O-Crimp field crimping system.
**Adapter included 3/8" A.B.S. to 3/8" male pipe. Adapter Catalog no. 1390X6X6.

Ready-Made Hose Assemblies

Air Brake Air Chamber Hose Lines

HOSE ASSY. I.D.	MALE PIPE	AIR BRAKE SWIVEL	LENGTH L (INCHES)	FACTORY MADE CATALOG NUMBER*	PREVIOUS CATALOG NUMBER
3/8"	1/4"	3/8"	18-1/8"	38166-01812	W28471
3/8"	1/4"	3/8"	20-3/8"	38166-02137	W28539
3/8"	1/4"	3/8"	22"	38166-02200	
3/8"	1/4"	3/8"	24-1/8"	38166-02412	W28472
3/8"	1/4"	3/8"	24-7/8"	38166-02487	
3/8"	1/4"	3/8"	26"	38166-02600	
3/8"	1/4"	3/8"	27-5/8"	38166-02762	
3/8"	1/4"	3/8"	28-3/8"	38166-02837	W28473
3/8"	1/4"	3/8"	29-1/8"	38166-02912	
3/8"	1/4"	3/8"	30-1/8"	38166-03012	W28550
3/8"	1/4"	3/8"	32"	38166-03200	W28552
3/8"	1/4"	3/8"	34"	38166-03400	
3/8"	1/4"	3/8"	34-3/8"	38166-03437	W28554
3/8"	1/4"	3/8"	36-1/8"	38166-03612	W28555
3/8"	1/4"	3/8"	38-1/8"	38166-03812	
3/8"	1/4"	3/8"	40"	38166-04000	
3/8"	1/4"	3/8"	41-1/8"	38166-04112	W28559
3/8"	1/4"	3/8"	42"	38166-04200	
3/8"	1/4"	3/8"	48"	38166-04800	
3/8"	1/4"	3/8"	60"	38166-06000	
3/8"	1/4"	3/8"	72"	38166-07200	

Air chamber hose assemblies can also be made using Weatherhead's H33806 hose, 33806P-104 and 33806P-Y76 hose ends, and 1390x6 adapter with the Coll-O-Crimp field crimping system.

*Adapter included 3/8" A.B.S. to 1/4" male pipe. Catalog No. 1390x6.

HOSE ASSY. I.D.	MALE PIPE	AIR BRAKE SWIVEL	LENGTH L (INCHES)	FACTORY MADE CATALOG NUMBER**	PREVIOUS CATALOG NUMBER
3/8"	3/8"	3/8"	18"	38097-01800	
3/8"	3/8"	3/8"	20"	38097-02000	
3/8"	3/8"	3/8"	24"	38097-02400	
3/8"	3/8"	3/8"	26"	38097-02600	
3/8"	3/8"	3/8"	28"	38097-02800	
3/8"	3/8"	3/8"	30"	38097-03000	
3/8"	3/8"	3/8"	32"	38097-03200	
3/8"	3/8"	3/8"	34"	38097-03400	
3/8"	3/8"	3/8"	40"	38097-04000	
3/8"	3/8"	3/8"	42"	38097-04200	
3/8"	3/8"	3/8"	60"	38097-06000	
3/8"	3/8"	3/8"	72"	38097-07200	

Air chamber hose assemblies can also be made using Weatherhead's H33806 hose, 33806P-106 and 33806P-Y76 hose ends, and 1390x6x6 adapter with the Coll-O-Crimp field crimping system.

**Adapter included 3/8" A.B.S. to 3/8" male pipe. Catalog no. 1390X6X6.

Ready-Made Hose Assemblies

Automobile, Light Truck Gas/Oil Lines*

Max. Working Pressure:
50 PSI
Temperature Range:
-40°F to +257°F

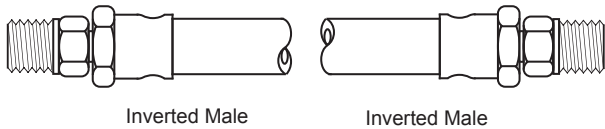
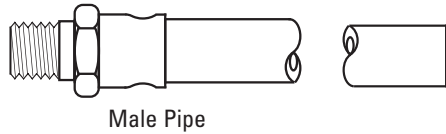
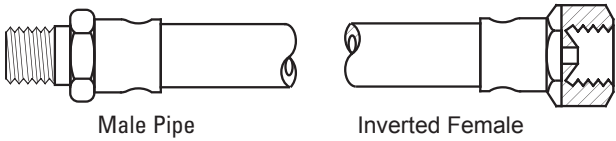
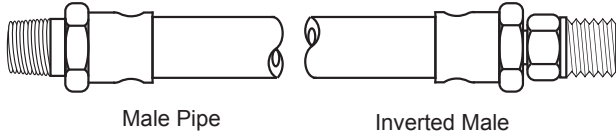

CATALOG NUMBER	OVERALL LENGTH	FITTING DESCRIPTION
11461	10"	1/8" Male Pipe x 1/4" Inv. Male
11462	12"	1/8" Male Pipe x 1/4" Inv. Male
11463	13"	1/8" Male Pipe x 1/4" Inv. Male
11464	15"	1/8" Male Pipe x 1/4" Inv. Male
11465	21"	1/8" Male Pipe x 1/4" Inv. Male
11466	28"	1/8" Male Pipe x 1/4" Inv. Male
11474	19"	1/8" Male Pipe x 1/4" Inv. Male
11477	17"	1/8" Male Pipe x 1/4" Inv. Male
11478	24"	1/8" Male Pipe x 1/4" Inv. Male

CATALOG NUMBER	OVERALL LENGTH	FITTING DESCRIPTION
11079	6-5/8"	1/8" Male Pipe x 5/16" Inv. Female
11076	8-1/4"	1/8" Male Pipe x 5/16" Inv. Female
11205	8-7/8"	1/8" Male Pipe x 5/16" Inv. Female
11215	9-3/8"	1/8" Male Pipe x 5/16" Inv. Female
11093	18"	1/8" Male Pipe x 5/16" Inv. Female
11217	7-1/2"	1/4" Male Pipe x 3/8" Inv. Female
11216	9"	1/4" Male Pipe x 3/8" Inv. Female

CATALOG NUMBER	OVERALL LENGTH	FITTING DESCRIPTION
11223	15-1/4"	1/4" Male Pipe (one end only), other end blank

CATALOG NUMBER	OVERALL LENGTH	FITTING DESCRIPTION
11486	10"	1/4" Inv. Male x 1/4" Inv. Male

APPLICATION
DATA

LOW & MEDIUM
PRESSURE HOSE

HIGH PRESSURE HOSE

SPECIALTY HOSE

ACCESSORIES &
ASSEMBLY INSTRUCTIONS

ADAPTERS & TUBE
HOSE ENDS

HOSE ASSEMBLY
EQUIPMENT

TECHNICAL DATA

Ready-Made Hose Assemblies

Automobile, Light Truck Gas/Oil Lines*

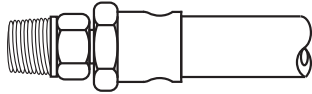

Male Pipe

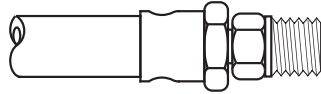

Inverted Male

CATALOG NUMBER	OVERALL LENGTH	FITTING DESCRIPTION
11080	5"	1/4" Inv. Male x 1/4" Inv. Female
11224	7"	1/4" Inv. Male x 1/4" Inv. Female
11089	10-5/8"	1/4" Inv. Male x 1/4" Inv. Female
11078	7"	5/16" Inv. Male x 5/16" Inv. Female
11212	7-7/8"	5/16" Inv. Male x 5/16" Inv. Female
11041	9"	5/16" Inv. Male x 5/16" Inv. Female
11208	10-3/4"	5/16" Inv. Male x 5/16" Inv. Female

Max. Working Pressure:
50 PSI

Temperature Range:
-40°F to +257°F

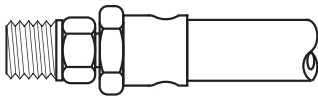

Inverted Male

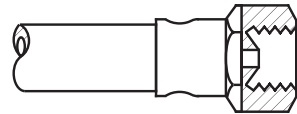

Inverted Female

CATALOG NUMBER	OVERALL LENGTH	FITTING DESCRIPTION
11219	6-1/4"	5/16" Inv. Female x 5/16" Inv. Female

*Automobile, Light Truck Universal Type Filter Lines

(1/4" SAE Swivel Nut to 1/8" Male Pipe)



CATALOG NUMBER	OVERALL LENGTH	CATALOG NUMBER	OVERALL LENGTH
81430-08	8"	81430-20	20"
81430-10	10"	81430-22	22"
81430-12	12"	81430-24	24"
81430-14	14"	81430-28	28"
81430-16	16"	81430-30	30"
81430-18	18"	81430-36	36"

Max. Working Pressure:
400 PSI

Temperature Range:
-40°F to +250°F

Note:

Hose End Material is Brass.

*The hose assemblies listed are for automobile or light truck (up to 3/4 ton pickup truck) application only. Consult Weatherhead Technical Support prior to any other use.

Accessories

Hose Cleaning System



The Jetcleaner™ hose cleaning system offers a revolutionary solution for the internal cleaning of bulk hose and finished hose assemblies. Using a low pressure air gun, the Jetcleaner system routes a foam projectile through the hose to thoroughly remove debris remaining from cutting, skiving and assembly operations. Available in kit form or as individual components, the Jetcleaner hose cleaning system is the system of choice for hose assembly professionals.

Hose Kit (P/N FT1355-01)

Includes:

Jetcleaner pistol, Hose nozzles, 1/4" through 2" ID, Adapter ring, Aluminum case, Quick disconnect coupling

Note: Hose projectiles (P/N FT1355-3-size) not included in kit.

Also available individually:

Jetcleaner pistol – FT1355-1-01

Hose nozzles – FT1355-2-size

Hose projectiles – FT1355-3-size

Coupling nozzles – FT1355-4-size

Coupling projectiles – FT1355-5-size

Adapter ring – FT1355-10-01

Carrying case – FT1355-11-02

Hose Insertion Gages



P/N FF90308

For use with all hose with WeatherGRIP™ hose ends.

Improve hose assembly reliability with these easy to use aluminum gages that are designed to ensure proper hose end depth during pre-assembly.

Simply bottom the hose in the appropriately marked cavity and scribe a mark on the hose flush with the top surface of the gauge. Insert the hose end until the back of the socket is aligned with scribe line.

PART NUMBER	USAGE
FF90308-01	For use with all hoses that mate with -4 through -16 WeatherGRIP™ hose ends
FF90308-02	For use with all hoses that mate with -20 WeatherGRIP™ hose ends
FF90308-03	For use with all hoses that mate with -12, -16, -20 4SP/6SP hose ends

Accessories

Hose Spacers



PART NUMBER	DESCRIPTION
HSM-48	Case of 48 mixed Hose Spacers

Features:

- Prevents hose abrasion at points of contact
- Helps keep hoses organized
- Prevents damage from unrestrained hoses
- Easy to install
- Available in 4 sizes – 3/4", 1", 1 1/8", 1 3/8"
- Packed in colorful counter display boxes of 48 – cable ties included
- Also available in mixed boxes of 48 (12 each size) or refill bags of 12

Hose Protectors



PART NUMBER	DESCRIPTION
HP4*	4" Hose Protector Case of 50
HP6*	6" Hose Protector Case of 50
HP8*	8" Hose Protector Case of 50
HP10*	10" Hose Protector Case of 10
HP12*	12" Hose Protector Case of 10
HPM*	Mixed Hose Protectors Case of 60

*Hose protectors available in black, orange or yellow.

Abrasion Protection For:

- Hydraulic Hoses
- Battery Cables
- Wiring Harness
- Brake Systems
- Fuel Lines
- Air Lines
- Radiator Hoses
- Oil Lines

Features:

- Extremely high wear factor
- Formulated to resist solvents, oils, grease, gasoline, etc.
- 3 grooves protect cable ties and prevent slipping
- Operating temperature range is -40° to 430°F.
- Exceptionally cost effective
- Easy installation in minutes – no need to remove hose
- Packed in easy to assemble, colorful, counter display box
- Available in 3 sizes – 4", 6" and 8" – cable ties included

Market Applications:

- Farming
- Industrial
- Trucking
- Mining
- Construction
- Aviation Support
- Public Transportation
- Road Maintenance
- Waste Management
- Original Equip. Manuf.

Flaretite* Seals

The ideal product to enhance new installations of SAE 37° connections, as well as seal off minor leaks and weeping connections.



Features

- Ribbed insert design
- Coated with Loctite** sealant
- Economical method to reduce minor leaks and weeping connections
- Built-in clip to attach the Flaretite seal to the nose of the SAE 37 degree connection
- Available sizes: -04 through -32

Benefits

- Multiple surface contact points
- Locks the joint and fills surface imperfections
- Saves time & money associated with maintenance and rework
- Quick & easy assembly

Flaretite Seal Joint Section of Applied Seal

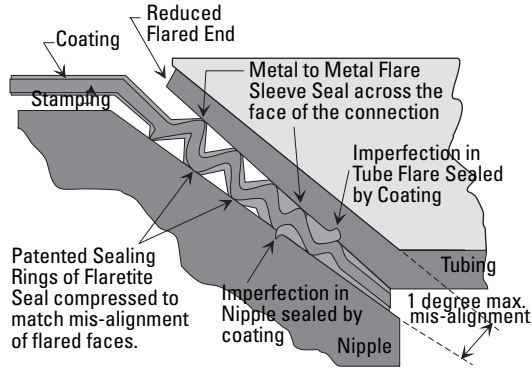

Standard Flared Connection (Section)

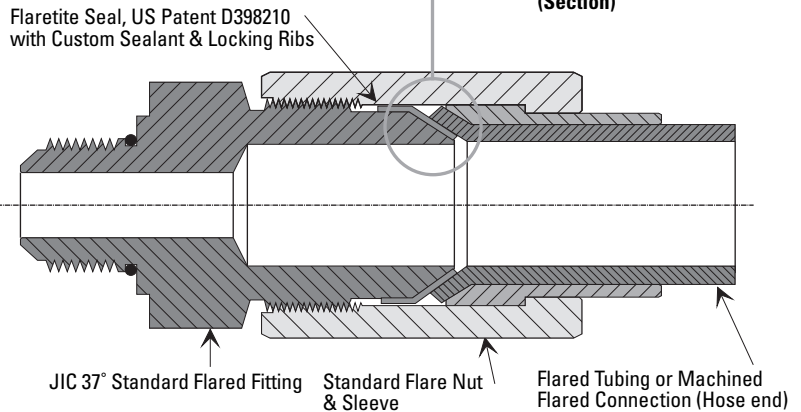

Assembly and Torque Requirements

To assemble an SAE 37° connection using a Flaretite seal, simply push the Flaretite seal onto the male portion of the connection. The built-in clip will hold the Flaretite seal onto the male half.

During assembly ensure:

- The seal is fitted squarely to the conical nose of the JIC fitting -37° flare.
- The sealing faces of the flared connector part are clean and free of burrs.
- The flared joint is correctly tightened with recommended torque settings noted below.

SEAL SIZE	PACKAGE PART NUMBER	NUMBER OF SEALS PER PACKAGE
-04	FF13267	100
-06	FF13268	100
-08	FF13269	100
-10	FF13270	100
-12	FF13271	100
-16	FF13272	50
-20	FF13273	50
-24	FF13570	25
-32	FF13571	10

* Flaretite is a registered trademark of Flaretite Inc. All photos and the name Flaretite are the property of Flaretite Inc.

** Loctite is a registered trademark of Henkel Loctite Corporation.

RECOMMENDED TORQUE SETTINGS:

Tolerance: +10% -0%

-04 (1/4")	SAE 37°: 14lb-ft.	-10 (5/8")	SAE 37°: 80lb-ft.	-20 (1-1/4")	SAE 37°: 190lb-ft.
-06 (3/8")	SAE 37°: 26lb-ft.	-12 (3/4")	SAE 37°: 110lb-ft.	-24 (1-1/2")	SAE 37°: 220lb-ft.
-08 (1/2")	SAE 37°: 55lb-ft.	-16 (1")	SAE 37°: 140lb-ft.	-32 (2")	SAE 37°: 325lb-ft.

Bundling Sleeves



Specifications

PART NUMBER	FITS BUNDLE OUTER DIA.	CIRCUMFERENCE OF BUNDLE TO BE COVERED	SLEEVE WIDTH	BULK ROLL LENGTH	LENGTH TOLERANCE	ORDERING: UNIT OF MEASURE
			laid flat inches			
A4926	2.0	6	7 ¾	150	(+1 ft., - 0 ft)	Ft.
A4927	3.0	9.4	11	150	(+1 ft., - 0 ft)	Ft.
A4928	4.0	12.5	14	150	(+1 ft., - 0 ft)	Ft.
A4929	5.0	15.7	17 ¼	150	(+1 ft., - 0 ft)	Ft.
A4930	6.0	18.8	20 ¾	150	(+1 ft., - 0 ft)	Ft.

Hydraulic lines are subject to tremendous stress and wear in use. Lines that are allowed to move freely are easily abraded, crimped, or cut. But common methods for binding hydraulic lines, such as cable ties, can restrict their movement too much as they expand and contract.

We have the answer.

Our Bundling Sleeves hold lines securely in place to protect them from damage, while providing enough flexibility for normal operation.

The sleeves can be removed and replaced quickly, allowing easy access to individual hoses for repair.

Features

- Tight bundling and secure hose containment
- Choice of sizes and colors for visibility and aesthetics
- Resistant to heat, ozone, and abrasion
- Easy removal and replacement

Applications

- Case IH Patriot Sprayer SPX 4260 uses Sidewinder Sleeves to protect hydraulic and brake hoses
- Champion Road Machinery Sales uses Sidewinder Sleeves to protect hydraulic lines
- Rosco Manufacturing Company uses Sidewinder Sleeves on Model RA-200 Pothole Filler

Benefits

- Increases productivity in assembly and reassembly of hose bundles
- Reduces contamination of hoses during bundle assembly
- Forces routing of hydraulic lines for safety and efficiency
- Reduces risk of hose bursts, resulting in greater operator safety
- Reduces time spent on field repairs
- Replaces inefficient bundling methods and line-damaging cable ties
- Eliminates cumbersome winding of spiral formed products
- Reduces "old sock syndrome"-bunching at end of bundled lines
- Eliminates line contamination during hose replacement

Materials

- 1050 Ballistic Nylon, .71mm thickness

Coating

- Urethane

Color

- Black

Ambient Operating Temperature Range

- 175° F

How to order

Part numbers above are stocked in 150 ft. shrink wrapped bulk rolls as rolled up unfastened.

Orders should be for the number of rolls needed, not footage.

150 ft. bulk rolls will be one continuous length.

Accessories

Bundling Straps



Merchandising kits for straps

Standard Duty

Part Number FF13502

Heavy Duty

Part Number FF13503

Contains:

Each Merchandising kit comes complete with a quantity of individually cellophane wrapped, bundling straps in both Cinch and Hanging Styles for bundling diameters of 8", 12", 16" & 20" sizes. (note the box will be stocked with approximately 1/2 of the available strap capacity to allow for lower kit pricing at start-up.) Re-supply merchandiser kit, by ordering the individually wrapped part numbers in the charts above.

The box is constructed to have a pop-up lid that can be positioned upright as an effective advertising backdrop. The box is shipped in a corrugated shipping container to prevent damage to the merchandising box.

Attached to the merchandising box by a wire lanyard, is a strap that can be used for demonstration

Bundling Straps hold hoses, cables, pipes, tubes and other items securely in place. They can be removed, adjusted and put back in place easily. The straps are made with a special hook-and-loop fastener developed for industrial applications, the safety industry and the military.

Unlike cable ties, Bundling Straps allow hoses and tubes to expand and contract in changing conditions. Cable ties must be destroyed when they are removed, but Bundling Straps can be used again and again with no loss of strength. The hook-and-loop fasteners used in Bundling Straps have superior shear strength and peel compared to those used in the garment industry.

Features

- Easy to remove and replace
- Adjustable to any size bundle
- Industrial strength strap fabric and fasteners
- Secure containment of hoses, cables and other items
- Clean, professional appearance

Cinching Strap (CS Series) Bundling Straps are designed for economical service applications, such as hose and cable bundling. All joints are ultrasonic welded and tested.

Hanging Strap (HS Series) Bundling Straps are held in place by a 3/8" grommet. The straps can be mounted vertically or horizontally.

Both cinching and hanging straps are available in standard duty or heavy duty. Heavy duty Bundling Straps are designed for severe industrial applications, reinforced with ballistic Cordura® nylon and ultrasonic welded to 1-1/2" hook-and-loop material. All heavy duty hardware is nickel-plated steel.

Benefits

- Reduces cost of managing cables and hoses
- Improves worker safety and productivity
- Reduces abrasion of bundled items
- Saves money through reusability

All Bundling Straps are in stock and ready for immediate shipment. They are sold in packages of 5, and discounts are available for volume quantities of 50, 100, 250, 500, and 1,000. Call to ask about special sizes, materials, colors or configurations.

Materials

Standard Duty

- 1050 Ballistic Nylon II Webbing, .71mm thickness with dense nylon backing.
- Standard Cinch and Hanging straps use a delrin plastic fastening loop.

Heavy Duty

- 1050 Ballistic Nylon II Webbing, 3.18mm thickness with dense nylon backing.
- Cinch and Hanging straps use a nickel plated steel 12 L.14 fastening loop

Coating

- Urethane

Color

- Black

Ambient Operating Temperature Range

- -40° - 250° F



Accessories

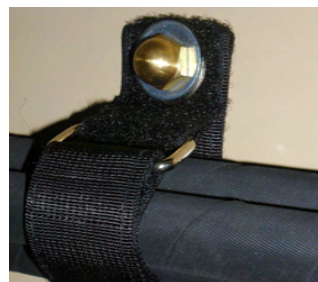
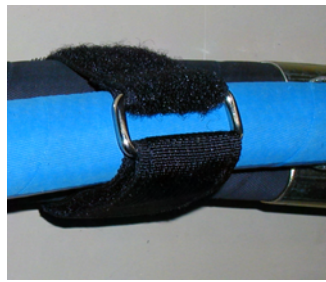

Bundling Straps

Cinch Straps

Standard Duty

Heavy Duty

BULK PACKED	INDIVIDUALLY CELLOPHANE WRAPPED	BULK PACKED	INDIVIDUALLY CELLOPHANE WRAPPED	CIRCUMFERENCE OF HOSE BUNDLE	STRAP LENGTH (FLAT)	ORDERING MEASUREMENT
Part Number	Part Number	Part Number	Part Number	Inches	Inches	
FF90519-4	FF90520-4	FF90521-4	FF90522-4	4.0	7 3/4	Each
FF90519-6	FF90520-6	FF90521-6	FF90522-6	6.0	11	Each
FF90519-8	FF90520-8	FF90521-8	FF90522-8	8.0	14	Each
FF90519-10	FF90520-10	FF90521-10	FF90522-10	10.0	17 1/4	Each
FF90519-12	FF90520-12	FF90521-12	FF90522-12	12.0	20 3/8	Each
FF90519-14	FF90520-14	FF90521-14	FF90522-14	14.0		Each
FF90519-16	FF90520-16	FF90521-16	FF90522-16	16.0		Each
FF90519-18	FF90520-18	FF90521-18	FF90522-18	18.0		Each
FF90519-20	FF90520-20	FF90521-20	FF90522-20	20.0		Each
	FF90520-22	FF90521-22		22.0		Each
	FF90520-24	FF90521-24		24.0		Each
	FF90520-26	FF90521-26		26.0		Each

Hanging Straps

Standard Duty

Heavy Duty

BULK PACKED	INDIVIDUALLY CELLOPHANE WRAPPED	BULK PACKED	INDIVIDUALLY CELLOPHANE WRAPPED	CIRCUMFERENCE OF HOSE BUNDLE	STRAP LENGTH (FLAT)	ORDERING MEASUREMENT
Part Number	Part Number	Part Number	Part Number	Inches	Inches	
FF90523-4	FF90524-4	FF90525-4	FF90526-4	4.0	7 3/4	Each
FF90523-6	FF90524-6	FF90525-6	FF90526-6	6.0	11	Each
FF90523-8	FF90524-8	FF90525-8	FF90526-8	8.0	14	Each
FF90523-10	FF90524-10	FF90525-10	FF90526-10	10.0	17 1/4	Each
FF90523-12	FF90524-12	FF90525-12	FF90526-12	12.0	20 3/8	Each
FF90523-14	FF90524-14	FF90525-14	FF90526-14	14.0		Each
FF90523-16	FF90524-16	FF90525-16	FF90526-16	16.0		Each
FF90523-18	FF90524-18	FF90525-18	FF90526-18	18.0		Each
FF90523-20	FF90524-20	FF90525-20	FF90526-20	20.0		Each
		FF90525-22	FF90526-22	22.0		Each
		FF90525-24	FF90526-24	24.0		Each
		FF90525-26	FF90526-26	26.0		Each

Hose and Gear Clamps

Hose Support

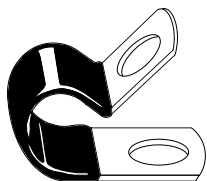

Typical Application:

Hose support for long hose lengths. Also used to insure proper hose routing where abrasion, moving parts or heat may exist.

Material: C1010 steel with 1/32" thick black vinyl cushion.

Plating: Zinc-plated dichromate finish.

CLAMPING DIA.	CATALOG NUMBER	BOLT HOLE
1/4	HK0509	1/4
3/8	HK0709	9/32
7/16	HK0809	9/32
1/2	HK0913	13/32
9/16	HK1013	13/32
5/8	HK1113	13/32
11/16	HK1213	13/32
3/4	HK1313	13/32
13/16	HK1413	13/32
7/8	HK1513	13/32
15/16	HK1613	13/32
1	HK1713	13/32
1-1/16	HK1813	13/32
1-1/8	HK1913	13/32
1-3/16	HK2017	17/32
1-1/4	HK2117	17/32
1-3/8	HK2317	17/32
1-1/2	HK2517	17/32
1-9/16	HK2617	17/32
1-3/4	HK2917	17/32
1-7/8	HK3117	17/32
1-15/16	HK3217	17/32
2	HK3317	17/32
2-5/32	HK3417	17/32
2-21/32	HK3817	17/32

E.F.I. Hose Clamps

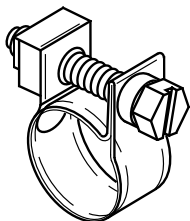

Typical Application:

Electronic fuel injection hose.

Material:

Plated carbon steel; 23/64" (9mm) band width.

CLAMP SIZE	CATALOG NUMBER	MINIMUM DIA.	MAXIMUM DIA.	NOMINAL DIA.
04	6207-004	.433	.551	.512
05	6207-005	.472	.590	.551
06	6207-006	.551	.669	.630

APPLICATION DATA

LOW & MEDIUM PRESSURE HOSE

HIGH PRESSURE HOSE

SPECIALTY HOSE

ACCESSORIES & ASSEMBLY INSTRUCTIONS

ADAPTERS & TUBE HOSE ENDS

HOSE ASSEMBLY EQUIPMENT

TECHNICAL DATA

Hose and Gear Clamps

Round Wire Clamps

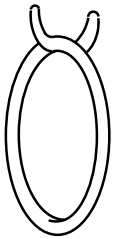

Typical Application:

Industrial, automotive, agriculture, and general market applications.

Material:

Carbon steel spring wire.

Plating:

Zinc-plated dichromate finish.

CLAMP SIZE	HOSE SIZE	CATALOG NUMBER	MINIMUM DIA.	MAXIMUM DIA.	NOMINAL DIA.
06	1/4	1538	.370	.380	.375
08	5/16	1539	.551	.573	.562
10	3/8	1540	.610	.640	.625

Heavy Duty Hose Support Clamps



These heavy duty weld-based clamps are designed to securely hold hose in applications subject to impulsing, flexing and vibrating conditions. The clamps help prevent abrasion and extend hose life through proper routing. Clamps are rated to ambient temperature of +250°F.

P/N FF90311

CLAMP PART NUMBER	INSIDE DIAMETER	
	(MM)	(INCH)
FF90311-127	12.70	0.50
FF90311-137	13.70	0.54
FF90311-150	15.00	0.59
FF90311-160	16.00	0.63
FF90311-171	17.10	0.67
FF90311-174	17.40	0.69
FF90311-190	19.00	0.75
FF90311-205	20.50	0.81
FF90311-222	22.20	0.87
FF90311-239	23.90	0.94
FF90311-254	25.40	1.00
FF90311-266	26.60	1.05
FF90311-280	28.00	1.10
FF90311-300	30.00	1.18
FF90311-320	32.00	1.26
FF90311-334	33.40	1.31
FF90311-357	35.70	1.41
FF90311-381	38.10	1.50
FF90311-400	40.00	1.57
FF90311-422	42.20	1.66
FF90311-445	44.50	1.75
FF90311-483	48.30	1.90
FF90311-508	50.80	2.00
FF90311-572	57.20	2.25
FF90311-635	63.50	2.50
FF90311-700	70.00	2.76

Hose and Gear Clamps

Full and Micro Size Partial Stainless Steel Clamps SAE J1508 Type F

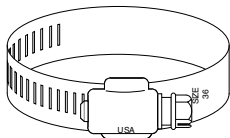

Clamps are suitable for a wide variety of uses including automotive, heavy-duty equipment, agriculture, and general industry.

Weatherhead partial stainless steel clamps utilize a 300 Series stainless steel band and housing with a steel case-hardened, zinc-plated and chromate-dipped screw. They feature a 9/16" (14.3mm) band housing with a 5/16" (8mm) hexagon and screwdriver slotted screw.

Micro part stainless clamps have a 5/16" (8mm) band and housing manufactured with a 300 Series stainless steel.

Full and Micro Size All Stainless Steel Clamps SAE J1508 Type F

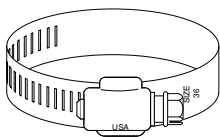

Weatherhead's all stainless steel construction offers maximum protection against corrosion. Applications include chemical, marine, food processing, dairy, automotive, electrical and plumbing.

Full size all stainless clamps are manufactured with 300 Series stainless steel. They feature a 9/16" (14.3mm) band and housing with a 5/16" (8mm) hexagon and screwdriver slotted screw.

Micro all stainless clamps have a 5/16" (8mm) band housing manufactured with a 300 Series stainless steel. The 1/4" (6.35mm) hexagon and screwdriver slotted screw features 410 stainless steel.

CLAMP SIZE	CATALOG NUMBER	MINIMUM DIA.	MAXIMUM DIA.	NOMINAL DIA.
*004	6205-004	7/32	5/8	1/4
*006	6205-006	5/16	7/8	1/2
006	6203-006	3/8	7/8	1/2
008	6203-008	7/16	1	9/16
010	6203-010	9/16	1-1/16	5/8
012	6203-012	9/16	1-1/4	3/4
016	6203-016	11/16	1-1/2	1
020	6203-020	3/4	1-3/4	1-1/4
024	6203-024	1-1/16	2	1-1/2
028	6203-028	1-5/16	2-1/4	1-3/4
032	6203-032	1-9/16	2-1/2	2
036	6203-036	1-13/16	2-3/4	2-1/4
040	6203-040	2-1/16	3	2-1/2
044	6203-044	2-5/16	3-1/4	2-3/4
048	6203-048	2-9/16	3-1/2	3
052	6203-052	2-13/16	3-3/4	3-1/4
056	6203-056	3-1/16	4	3-1/2
064	6203-064	3-9/16	4-1/2	4
072	6203-072	4-1/16	5	4-1/2
080	6203-080	4-5/8	5-1/2	5
088	6203-088	4-3/32	6	5-1/2
096	6203-096	4-1/2	6-1/2	6
104	6203-104	5	7	6-1/2

*Micro size clamps

CLAMP SIZE	CATALOG NUMBER	MINIMUM DIA.	MAXIMUM DIA.	NOMINAL DIA.
*004	6206-004	7/32	5/8	1/4
*006	6206-006	5/16	7/8	1/2
006	6204-006	3/8	7/8	1/2
008	6204-008	7/16	1	9/16
010	6204-010	9/16	1-1/16	5/8
012	6204-012	9/16	1-1/4	3/4
016	6204-016	11/16	1-1/2	1
020	6204-020	3/4	1-3/4	1-1/4
024	6204-024	1-1/16	2	1-1/2
028	6204-028	1-5/16	2-1/4	1-3/4
032	6204-032	1-9/16	2-1/2	2
036	6204-036	1-13/16	2-3/4	2-1/4
040	6204-040	2-1/16	3	2-1/2
044	6204-044	2-5/16	3-1/4	2-3/4
048	6204-048	2-9/16	3-1/2	3
052	6204-052	2-13/16	3-3/4	3-1/4
056	6204-056	3-1/16	4	3-1/2
064	6204-064	3-9/16	4-1/2	4
072	6204-072	4-1/16	5	4-1/2
080	6204-080	4-5/8	5-1/2	5
088	6204-088	4-3/32	6	5-1/2
096	6204-096	4-1/2	6-1/2	6
104	6204-104	5	7	6-1/2

*Micro size clamps