



EAT•N

Weatherhead

Tube and Pipe Fitting Master Catalog

Product Focus



Table of Contents

APPLICATION DATA

Safety Information	1-2
Visual Quick Reference Index	3-13
Numbering Systems	14
Tube Fitting Selector Chart	15
Fitting Identification	16-18
Tubing Selection Information	19-25
Flare Dimensions	26
Tubing Installation	27
Chemical Compatibility Chart	28-32

PLASTIC TUBING

Nylon 11 (Air Brake)	33
Polyvinyl Chloride	33
Nylon 6/6	34
Polyethylene	34
Polyamide - Nylon 11	35
Polyamide - Nylon 11 Metric Tubing	35

BRASS FITTINGS

Introduction	36
Inverted Flare	37-41
SAE 45° Flare	42-47
Compression	48-53
SELFALIGN®	54-59
POLYLINE® FLARELESS	60-64
PUSH>CONNECT®	65-70
PUSH>CONNECT® METRIC	71-74
PUSH>CONNECT® FLOW CONTROLS	75-76
PLUS, PUSH>CONNECT® PLUS	77-78
MINI-BARB®	79-82
QUICK>CONNECT® Airbrake	83-90
Air Brake (Nylon Tubing)	91-96
Air Brake (Copper Tubing)	97-101
THREADED SLEEVE®	102-103
Pipe	104-109
Needle Valves	110-113
Drain Cocks	114-116
Truck Valves & Plastic Drain-Cocks	117
Ground Plug & Multiple Shut-Off Valves	118-120
Special Adapters	121-125
Hydraulic Brake Fittings	126-127
Steel Brake Lines	128

PLASTIC FITTINGS

Molded Compression Tube Fittings	129-136
Plastic Connection Fittings	137

STEEL FITTINGS

Introduction	138
Pipe	139-147
NPSM Female Swivel Adapters	148-153
FOR-SEAL®	154-163
SAE 37° (JIC) FLARE-TWIN®	164-183
Straight Thread O-Ring Adapters	184-194
Flareless - 7000 Series ERMETO®	195-207
Split Flange Adapters and Kits	208-209
Din	210-212
Metric	213-214
BSP	215-218

FITTING RELATED PRODUCTS

Coiled Air Brake & Gladhand Couplings	219
Cable Controls	220-221
Presetting Tools	222
Counterbore Tools & O-Ring Kit	223
Measuring Tool Kits	224
Assembly & Tube Cutting Equipment	225-226
Tube Bending Tools	227
Tube Flaring Tools	228-229
Brazing Tools	229-230
Label Sets	230
Cabinets	231
Assortments	232-249

MISCELLANEOUS

Weatherhead Locations and Certifications	250
Conversion Chart	251
Technical Torque Specifications	252
Technical Support Information	253
Glossary	254-258
Index	259-265
Weatherhead Warranty	Back Inside Cover

BUILT TO A TOUGHER STANDARD™

WEATHERHEAD®

WARNING

Selection of Tubing

Selecting the proper Weatherhead tubing for a given application is essential to the proper operation and safe use of the tubing and related equipment. Inadequate attention to the selection of the tubing for your application can result in leakage, bursting, or other failure which can cause serious bodily injury or property damage from spraying fluids or flying projectiles. In order to avoid serious bodily injury or property damage resulting from selection of the wrong tubing, you should carefully review the information in this catalog. Some of the factors that are involved in the selection of the proper tubing are:

- material of tubing
- tubing size
- tubing length
- tubing end connections
- fluid conveyed (compatibility)
- bends
- temperature
- tubing pressure rating
- installation design

These factors and the other information in this catalog should be considered by you in selecting the proper tubing for your application. If you have any questions regarding the proper tubing for your application, please contact Boston Weatherhead, Technical Support 1-800-776-3262.

Proper Selection of Tube Fittings

Selection of the proper Weatherhead tube fittings for the application is essential to the proper operation and safe use of tubing and related equipment. Inadequate attention to the selection of the end fittings for your application can result in tube leakage, bursting, or other failure which can cause serious injury or property damage from spraying fluids or flying projectiles. In order to avoid serious bodily injury or property damage resulting from selection of the wrong tube end fitting, you should carefully review the information in this catalog. Some of the factors which are involved in the selection of the proper tube end fittings are:

- tube fitting
- compatibility with tubing
- temperature
- installation design
- tubing size
- corrosion requirements

These factors and the other information in this catalog should be considered by you in selecting the proper tube end fitting for your application.

If you have any questions regarding the proper tube end fittings for your application, please contact Boston Weatherhead, Technical Support at 1-800-776-3262.

 **WARNING****Tubing Installation**

Proper installation of the tubing is essential to the proper operation and safe use of the tubing and related equipment. Improper installation of the tubing can result in serious injury or property damage. In order to avoid serious bodily injury or property damage resulting from improper installation of the tubing, you should carefully review the information in this catalog regarding tubing installation. Some of the factors you must consider in installing the tubing properly are:

- proper installation procedures
- protection from high temperature sources
- stress
- changes in length
- twisting
- rubbing and abrasion

These factors and other information in this catalog regarding tubing installation should be considered by you before installing the tubing.

If you have any questions regarding proper installation of the tubing, please contact Boston Weatherhead, Technical Support 1-800-776-3262.

Tubing Assembly

Changes in materials, finishes, and assembly techniques may affect the sealing or holding capability of the joint. Due to the great variety of possible assembly scenarios, assembly procedures should be tested to determine if the joint is adequate for its intended use. We stress the importance of referring to assembly instructions on page 9 for determining the appropriate tightening procedure. Improper assembly or overtightening could result in fitting leakage, tubing separation or other failures which could cause serious bodily injury or property damage from spraying fluids or flying projectiles.

These factors and other information in this catalog regarding tubing assembly should be considered by you before installing the tubing.

If you have any questions regarding proper assembly and installation of the tubing, please contact Boston Weatherhead, Technical Support 1-800-776-3262.

Fitting Dimensions

Boston Weatherhead molded compression fittings as described in this catalog may not reflect running changes made to improve part performance. Check with Boston Weatherhead, Technical Support 1-800-776-3262 in critical applications.

Operating Pressures

Operating pressures of Boston Weatherhead molded compression fittings are regulated by ambient and fluid temperatures, type of fluid being carried, tubing type and conditions of mechanical abuse. Pressures in excess of above specifications in all fitting sizes should be tested by the customer for their particular application.

INVERTED FLARE

Tube Nut (Steel) <p>105x pg. 38</p>	Tube Nut (Brass) <p>100x pg. 38</p>	Plug (Steel) <p>131x pg. 38</p>	Tube Nut Long (Steel) <p>7896x pg. 38</p>	Union <p>252x pg. 38</p>	Adapter SAE 45° Flare to Inv. Flare <p>pg. 39</p>	Male Connector <p>202x pg. 39</p>
Female Connector <p>252x pg. 39</p>	Fuel Line Adapter <p>pg. 40</p>	45° Male Elbow <p>352x pg. 40</p>	Union Elbow <p>502x pg. 40</p>	Male Elbow <p>402x pg. 40</p>	Female Elbow <p>452x pg. 40</p>	Union Tee <p>702x pg. 41</p>
Male Run Tee <p>752x pg. 41</p>	Male Branch Tee <p>602x pg. 41</p>	Female Branch Tee <p>652x pg. 41</p>				







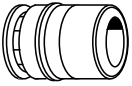
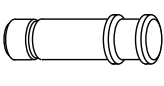
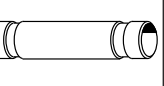
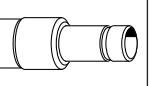
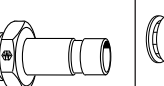
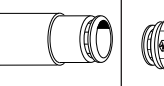
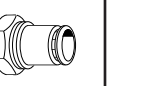
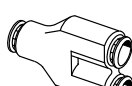
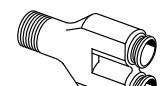
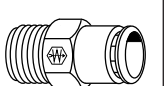

POLYLINE® FLARELESS

Plastic Sleeve <p>1260x pg. 61</p>	Brass Sleeve <p>1260x-B pg. 61</p>	Brass Nut <p>1261x pg. 61</p>	Brass Nut Assy (w/Plastic Sleeve) <p>1261x-A pg. 62</p>	Brass Nut Assy (w/Brass Sleeve) <p>1261x-B pg. 62</p>	Brass Bulkhead Nut <p>1202x pg. 62</p>	Union <p>1262x pg. 62</p>
Male Connector <p>1268x pg. 62</p>	Female Connector <p>1266x pg. 63</p>	Bulkhead Union <p>1274x pg. 63</p>	Male Elbow <p>1269x pg. 63</p>	Female Elbow <p>1270x pg. 63</p>	Union Tee <p>1264x pg. 64</p>	Male Run Tee <p>1271x pg. 64</p>
Male Branch Tee <p>1272x pg. 64</p>						

GROUND PLUG & MULTIPLE SHUT-OFFS

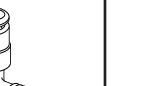
Draincock <p>pg. 118</p>	Ground Plug Drain <p>pg. 118</p>	Compression Flareless 3-Way Shut-Off <p>pg. 118</p>	SAE 45° Flare Double <p>pg. 118</p>	SAE 45° Flare Straight-Away <p>pg. 119</p>	Compression Double <p>pg. 119</p>	Compression Straight-Away <p>pg. 119</p>
Male to Female Pipe <p>pg. 119</p>	Truck Shut-Off to Female Pipe <p>pg. 119</p>	Marine Shut-Off Male to Female Pipe <p>pg. 120</p>	Female Pipe <p>pg. 120</p>	3-Way Shut-Off <p>pg. 120</p>	3-Way Multiple Shut-Off <p>pg. 120</p>	4-Way Multiple Shut-Off <p>pg. 120</p>

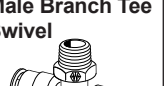

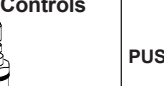



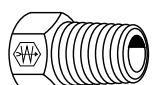
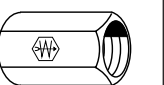
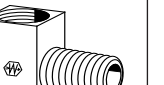







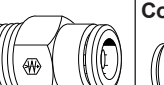
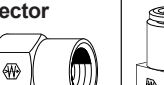
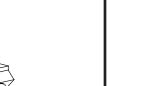

PUSH > CONNECT

Cartridge  Metric 1611x pg. 71 66	Plug (Plastic)  Metric 1129x pg. 71 66	Double Union  Metric 1105x pg. 71 66	Reducer  Metric 1109x pg. 71 66	Stem Adapter  Metric 1180x pg. 71 67	Union  Metric 1162x pg. 71 67	Bulkhead Union  Metric 1174x pg. 71 67
Union "Y"  Metric 1107x pg. 72 67	Male "Y"  Metric 1108x pg. 72 68	Male Connector  Metric 1168x pg. 72 68	Female Connector  Metric 1166x pg. 72 68	Union Elbow  Metric 1165x pg. 73 68	Swivel Male Elbow  Metric 1169x-S pg. 73 69	Male Elbow  Metric 1169x pg. 73 69
Union Tee  Metric 1164x pg. 73 69	Male Run Tee Swivel  Metric 1171x-S pg. 74 69	Male Branch Tee Swivel  Metric 1172x-S pg. 74 70	Stud Manifolds  pg. 70	Banjos  pg. 70	Flow Controls  pg. 76	PUSH > CONNECT PLUS see pages 77 & 78.

THREADED SLEEVE

Nut  6100x pg. 103	Male Connector  6200x pg. 103	Union  6300x pg. 103	Male Elbow  6400x pg. 103			
--	---	--	---	--	--	--



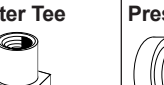
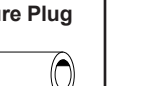







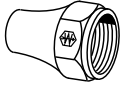
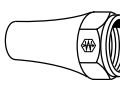
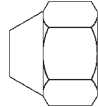
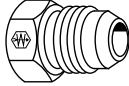
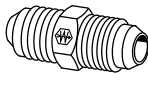



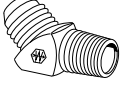

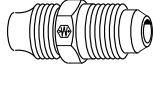

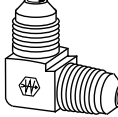
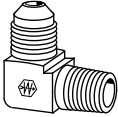
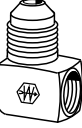

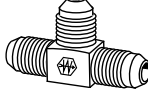
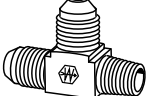
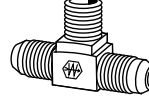
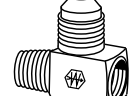

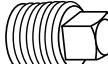

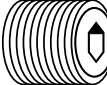
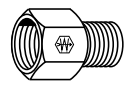

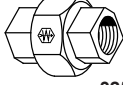
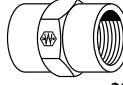

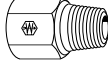
QUICK > CONNECT AIR BRAKE

Encapsulated Cartridge  1861x pg. 85	Union  1862x pg. 85	Bulkhead Union  1874x pg. 85	Female Bulkhead Union  1873x pg. 85	Male Connector  1868x pg. 86	Female Connector  1866x pg. 86	Male Elbow 45°  1880x pg. 86
Swivel Male 45° Elbow  1880x-S pg. 87	Union Elbow  1865x pg. 87	Male Elbow 90°  1869x pg. 87	Male Elbow 90° Long  1869x-L pg. 87	Swivel Male 90° Elbow  1869x-S pg. 88	Female Elbow  1870x pg. 88	Union Tee  1864x pg. 88
Male Run Tee  1871x pg. 89	Swivel Male Run Tee  1871x-S pg. 89	Male Branch Tee  1872x pg. 89	Swivel Male Branch Tee  1872x-S pg. 90	Female Branch Tee  1877x pg. 90	Adapter Tee  1883x pg. 90	Pressure Plug  1829x pg. 90



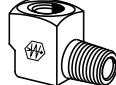

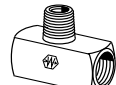

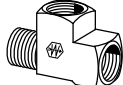
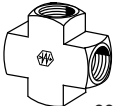



Brass Fittings

Visual Index

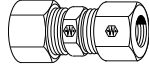

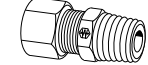
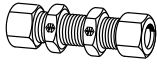



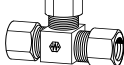
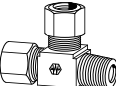
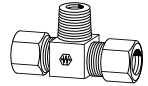
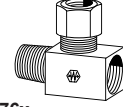



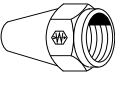



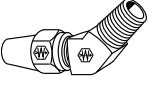

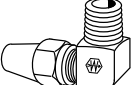
APPLICATION

SAE 45° FLARE						
Nut  1110x pg. 43	Long Nut  41x pg. 43	Cap  40x pg. 43	Plug  39x pg. 43	Union  42x pg. 43	Male Connector  48x pg. 44	Female Connector  46x pg. 44
Male Ball Check Connector  43x pg. 44	45° Male Elbow  54x pg. 44	Fem 45° Flare Swivel to Male SAE 45° Elbow (Steel)  9154x pg. 45	AC Type Adapter  pg. 45	Adapter SAE 45° Flare to Inv. Flare  pg. 45	Union Elbow  55x pg. 45	Male Elbow  49x pg. 46
Female Elbow  50x pg. 46	90° Elbow 45° Female Swivel to SAE 45° (Steel)  9151x pg. 46	Union Tee  44x pg. 47	Male Run Tee  51x pg. 47	Male Branch Tee  45x pg. 47	Adapter Tee  56x pg. 47	
PIPE						
Cap  3129x pg. 105	Slotted Plug  3150x pg. 105	Square Head Plug  3151x pg. 105	Hex Head Plug  3152x pg.	Hex Socket Plug  3153x pg. 105	Adapter  3200x pg. 105	Bushing  3220x pg. 106
Union  3250x pg. 106	Coupling  3300x pg. 106	Reducer Coupling  3300x pg. 106	Restriction Pipe Adapter  pg. 106	Fuel Line Adapter  pg. 107	Hex Nipple  3325x pg. 107	Close Nipple  3326x pg. 107
Long Nipple  3331x pg. 107	Bulkhead Coupling (brass)  pg. 108	45° Street Elbow  3350x pg. 108	Street Elbow  3400x pg. 108	Elbow  3500x pg. 109	Male Branch Tee  3600x pg. 109	Tee  3700x pg. 109
Male Run Tee  3750x pg. 109	Cross  3950x pg. 109					

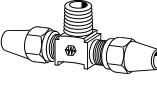
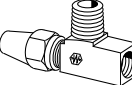





COMPRESSION & SELFALIGN FITTINGS

Tube Support For Plastic Tubing  2030x pg. 49 & 56	Sleeve  60x pg. 49 601x pg. 56	Nut  61x pg. 49 611x pg. 56	Long Nut  1611x pg. 50 & 56	Bulkhead Nut  0102x pg. 50 & 56	Union  62x pg. 50 621x pg. 57	Male Connector  68x pg. 50 681x pg. 57
Female Connector  66x pg. 51 661x pg. 57	Male Ball Check Connector  63x pg. 51 631x pg. 57	Bulkhead Union  74x pg. 51 741x pg. 58	Male Elbow  69x pg. 52 691x pg. 58	Union Elbow  65x pg. 52 651x pg. 58	Female Elbow  70x pg. 52 701x pg. 58	Union Tee  64x pg. 53 641x pg. 59
Male Run Tee  71x pg. 53 711x pg. 59	Male Branch Tee  72x pg. 53 721x pg. 59	Adapter Tee  76x pg. 53				



AIR BRAKE FITTINGS FOR COPPER TUBING

Sleeve  1360x pg. 98	Nut  1361x pg. 98	Union  1362x pg. 98	Male Connector  1368x pg. 98	Female Connector  1366x pg. 99	45° Male Elbow  1380x pg. 99	Union Elbow  1365x pg. 99
90° Male Elbow  1369x pg. 99	90° Male Elbow Long  1369x-L pg. 99	90° Female Elbow  1370x pg. 100	Union Tee  1364x pg. 100	Male Run Tee  1371x pg. 100	Male Branch Tee  1372x pg. 100	Adapter Tee  1382x pg. 100
Bulkhead Coupling (Brass)  pg. 101	Bulkhead Coupling (Brass)  pg. 101	Bulkhead Coupling (Brass)  pg. 101	Drain Cock  W15310 pg. 101	Shut-Off Valve  W2033L pg. 101	External Seat Draincock  145 pg. 101	

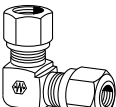
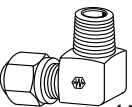
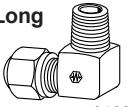
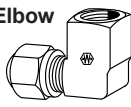
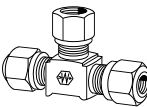
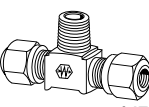
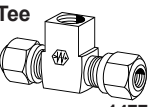

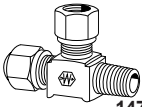
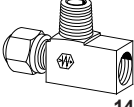
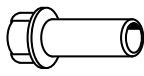

AIR BRAKE FITTINGS FOR NYLON TUBING

Sleeve  1460x pg. 92	Nut  1461x pg. 92	Union  1462x pg. 92	Male Connector  1468x pg. 93	Female Connector  1466x pg. 93	Bulkhead Union  1474x pg. 93	45° Male Elbow  1480x pg. 93
Union Elbow  1465x pg. 94	90° Male Elbow  1469x pg. 94	90° Male Elbow Long  1469x-L pg. 94	90° Female Elbow  1470x pg. 94	Union Tee  1464x pg. 95	Male Branch Tee  1472x pg. 95	Female Branch Tee  1477x pg. 95

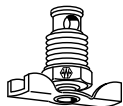
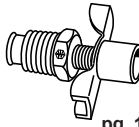

AIR BRAKE FITTINGS FOR NYLON TUBING CONTINUED

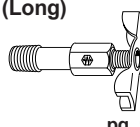
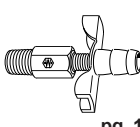
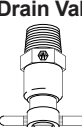
Male Run Tee  1471x pg. 95	Adapter Tee  1482x pg. 96	Insert  1484x pg. 96	Gauge Ring  1485x pg. 96			
---	--	---	---	--	--	--

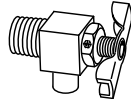
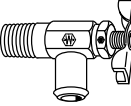
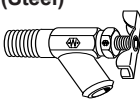
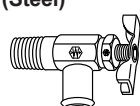
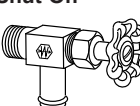
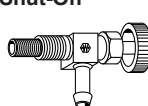
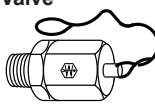
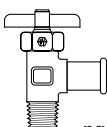
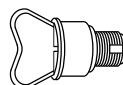



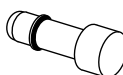
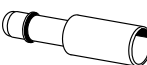
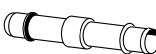
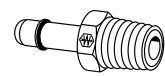
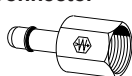
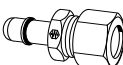

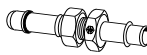
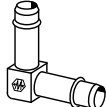
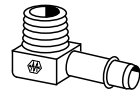
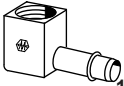
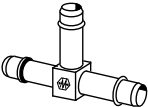
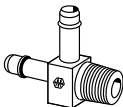
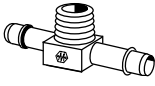
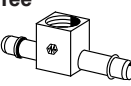
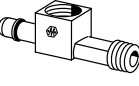

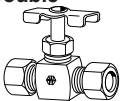

DRAINCOCKS

External Seat  pg. 114	External Seat  pg. 114	Internal Seat  pg. 114	Internal Seat (Long)  pg. 114	Internal Seat  pg. 115	Internal Seat Drain Valve  pg. 115	Air Vent  pg. 115
Angle Bib Drain  pg. 115	Angle Bib Drain  pg. 115	Hose to Pipe (Steel)  pg. 116	Hose to Pipe (Steel)  pg. 116	Pipe to Hose Shut-Off  pg. 116	Gasoline Shut-Off  pg. 116	Air Tank Drain Valve  pg. 116
Truck Valves  pg. 117	Plastic Drain Cocks  pg. 117					

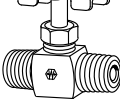

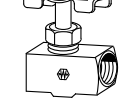



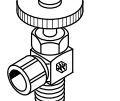































MINI-BARB®

Plug  1073x pg. 80	Solder Connector  1079x pg. 80	Union  1062x pg. 80	Male Connector  1068x pg. 80	Female Connector  1066x pg. 80	Compression Connector  1078x pg. 80	Bulkhead Compression Connector  1067x pg. 81
Bulkhead Union  1074x pg. 81	Union Elbow  1065x pg. 81	90° Male Elbow  1069x pg. 81	90° Female Elbow  1070x pg. 81	Union Tee  1064x pg. 82	Male Run Tee  1071x pg. 82	Male Branch Tee  1072x pg. 82
Female Branch Tee  1077x pg. 82	Adapter Tee  1075x pg. 82					

NEEDLE VALVES

Compression Double  pg. 111	Compression Straight-Away  pg. 111	Compression Angle  pg. 111	Inverted Straight-Away  pg. 111	Male Pipe  pg. 112	Female to Male Pipe  pg. 112	Female Pipe  pg. 112
SAE 45° Flare Double  pg. 112	SAE 45° Flare Straight-Away  pg. 113	SAE 45° Flare Angle  pg. 113	Polyline Straight-Away  pg. 113	Polyline Angle  pg. 113		













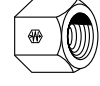
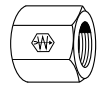

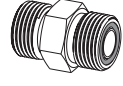
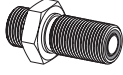
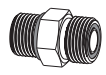
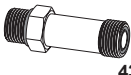
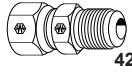
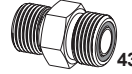







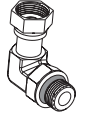
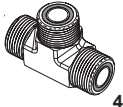











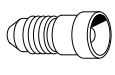

PIPE FITTINGS

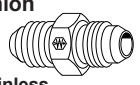
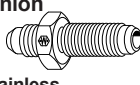
Seal-Nut for Male Pipe Threads  C3059x pg. 140	Hex Socket Plug  C3169x pg. 140	Square Head Plug  C3179x pg. 140	Hex Head Plug  Stainless Steel No. C3159x 3171x pg. 140	Bushing  Stainless Steel No. C3109x 3121x pg. 141	Straight Thread O-Ring to Female Pipe Adapter  C3269x pg. 141	Adapter  Stainless Steel No. C3209x 3221x pg. 141
Female Straight Thread O-Ring to Male Pipe Adapter  C3239x pg. 142	Coupling  Stainless Steel No. C3309x 3321x pg. 142	Hex Nipple  Stainless Steel No. C3069x 3081x pg. 142	Male Connector  4205x pg. 142	Male Straight Thread O-Ring to Male Pipe Adapter  C3249x pg. 142	Bulkhead Coupling  W05465 pg. 143	Bulkhead Coupling  W05498 pg. 143
Bulkhead Coupling  W05730 pg. 143	45° Elbow  C3559x pg. 143	45° Elbow  TF3559x pg. 143	45° Street Elbow  Stainless Steel No. C3359x 3371x pg. 143	45° Street Elbow  TF3359x pg. 143	90° Elbow  Stainless Steel No. C3509x 3521x pg. 144	90° Elbow  TF3509x pg. 144
90° Street Elbow  Stainless Steel No. C3409x 3421x pg. 144	90° Street Elbow  TF3409x pg. 144	90° Straight Thread O-Ring Male Elbow  C3459x pg. 145	90° Straight Thread O-Ring Male Elbow  TF3459x pg. 145	90° Straight Thread O-Ring Male Elbow Long  C3469x pg. 145	90° Straight Thread O-Ring Male Elbow to Male Pipe  TF3569x pg. 145	90° Male Elbow  Stainless Steel No. C3529x 3541x pg. 146
90° Male Elbow  TF3529x pg. 146	Tee  Stainless Steel No. C3709x 3721x pg. 146	Tee  TF3709x pg. 146	Male Branch Tee  Stainless Steel No. C3609x 3621x pg. 146	Male Branch Tee  TF3609x pg. 146	Male Run Tee  Stainless Steel No. C3759x 3771x pg. 147	Male Run Tee  TF3759x pg. 147
Female Run Tee  TF3805x pg. 147	Cross  C3959x pg. 147	Cross  TF3959x pg. 147	Straight Thread O-Ring  7629x pg. 147			

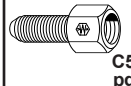
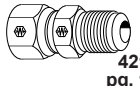

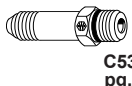
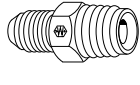
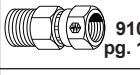



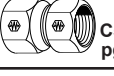
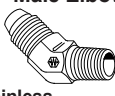
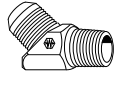
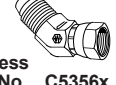
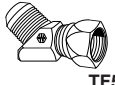



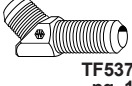









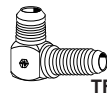









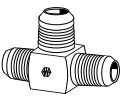
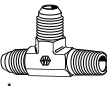
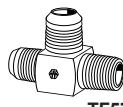
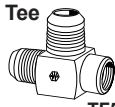
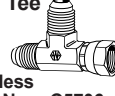
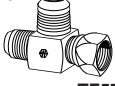
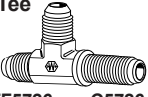
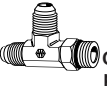
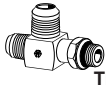

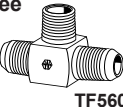
Steel Fittings

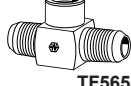
Visual Index

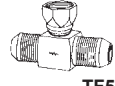

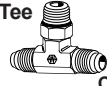

















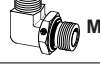

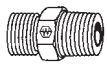
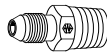

APPLICATION

FOR-SEAL®						
Tailpiece Silver Braze  4165x pg. 157	For-Seal® Cadmium Free Braze Ring  4640x pg. 157	Bulkhead Nut  4924x pg. 157	Nut  4105x pg. 157	Cap  4129x pg. 157	Plug  4229x pg. 158	Union  4305x pg. 158
Bulkhead Union  4325x pg. 158	Straight Thread O-Ring Connector  4315x pg. 158	Straight Thread O-Ring Extended Connector  4316x pg. 159	Male 37° Flare to Female For-Seal  4213x pg. 159	For-Seal Male to Ermeto Connector  4307x pg. 159	45° Male Elbow  4325x pg. 160	Straight Thread O-Ring Connector 45° Elbow  4365x pg. 160
45° Bulkhead Elbow  4375x pg. 160	Union 90° Elbow  4505x pg. 160	Bulkhead Union 90° Elbow  4525x pg. 161	90° Male Elbow  4405x pg. 161	Straight Thread O-Ring 90° Elbow  4515x pg. 161	90° Straight Thread Swivel  4535x pg. 162	Union Tee  4705x pg. 162
Straight Thread Branch Tee  4715x pg. 162	Straight Thread Run Tee  4716x pg. 163	Bulkhead Run Tee  4726x pg. 163	Male For-Seal Cross  4929x pg. 163	O-Ring For-Seal  4629x pg. 163		
JIC 37° FLARE-TWIN						
Sleeve 3 Piece  Stainless Steel No. C5165x 5177x pg. 166	Sleeve 3 Piece Metric  C5165x pg. 166	Nut 3 Piece  Stainless Steel No. C5105x 5117x pg. 166	Nut 2 Piece (Short)  C5125x pg. 166	Nut 2 Piece  C5115x pg. 166	Bulkhead Nut  Stainless Steel No. C5924x 7936x pg. 167	Cap  Stainless Steel No. C5129x 5141x pg. 167
Plug  Stainless Steel No. C5229x 5241x pg. 167	Reducer  Stainless Steel No. C5015x 5027x pg. 167	Small Hex Union  Stainless Steel No. C5305x 5317x pg. 168	Large Hex Union  Stainless Steel No. C5306x 5318x pg. 168	Bulkhead Union  Stainless Steel No. C5325x 5337x pg. 168	Male Connector  Stainless Steel No. C5205X 5217x pg. 169	Female Connector  C5255x pg. 169
Female Bulkhead Connector  C5275x pg. 169	Male SAE (JIC) 37° Female For-Seal  4213x pg. 170	Straight Thread O-Ring Connector  Stainless Steel No. C5315x 5327x pg. 170	Straight Thread O-Ring Extended Connector  C5316x pg. 170	Adapter  C5880x pg. 171	Female SAE (JIC) 37° Swivel to Male Pipe Adapter  9100x pg. 171	Male SAE (JIC) 37° to Male Metric Stand Pipe  MC5019x pg. 171
Male SAE (JIC) 37° to O-Ring Port Adapter  41157x pg. 171	Female SAE (JIC) 37° Swivel to Male Straight Thread O-Ring  C5216x pg. 172	Female SAE (JIC) 37° Swivel to Female Pipe  C5256x pg. 172	45° Male Elbow  Stainless Steel No. C5355x 5367x pg. 172	45° Male Elbow  TF5355x pg. 172	Swivel Nut 45° Elbow  Stainless Steel No. C5356x 5368x pg. 173	Swivel Nut 45° Elbow  TF5356x pg. 173

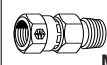









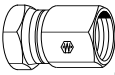
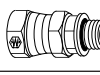

JIC 37° FLARE-TWIN cont.

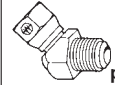
45° Bulkhead Union Elbow  TF5375x pg. 173	Straight Thread O-Ring 45° Elbow  C5365x pg. 174	Straight Thread O-Ring 45° Elbow  TF5365x pg. 174	90° Union Elbow  Stainless Steel No. 5517x C5505x pg. 174	90° Union Elbow  TF5505x pg. 174	90° Male Elbow  Stainless Steel No. 5417x C5405x pg. 175	90° Male Elbow  TF5405x pg. 175
90° Male Elbow Long  C5425x pg. 176	90° Male Elbow Long  TF5425x pg. 176	90° Male Elbow Extra Long  TF5435x pg. 176	Bulkhead Union 90° Elbow  Stainless Steel No. 5537x C5525x pg. 176	Bulkhead Union 90° Elbow  TF5525x pg. 176	90° Female Elbow  Stainless Steel No. 5467x C5455x pg. 177	90° Female Elbow  TF5455x pg. 177
Swivel Nut 90° Elbow  Stainless Steel No. 5518x C5506x pg. 177	Swivel Nut 90° Elbow  TF5506x pg. 177	90° Male Pipe to SAE (JIC) 37° Swivel  TF5406x pg. 178	Straight Thread O-Ring 90° Elbow  Stainless Steel No. 5527x C5515x pg. 178	Straight Thread O-Ring 90° Elbow  TF5515x pg. 178	Straight Thread O-Ring 90° Elbow Long  TF5515x pg. 179	Straight Thread O-Ring 90° Elbow Extra Long  TF5515x pg. 179
Union Tee  Stainless Steel No. 5717x C5705x pg. 179	Union Tee  TF5705x pg. 179	Male Run Tee  Stainless Steel No. 5767x C5755x pg. 180	Male Run Tee  TF5755x pg. 180	Female Run Tee  TF5805x pg. 180	Swivel Nut Run Tee  Stainless Steel No. 5718x C5706x pg. 180	Swivel Nut Run Tee  TF5706x pg. 180
Bulkhead Run Tee  TF5726x pg. 161 C5726x pg. 181	Straight Thread O-Ring Run Tee  C5716x pg. 181	Straight Thread O-Ring Run Tee  TF5716x pg. 181	Male Branch Tee  Stainless Steel No. 5617x C5605x pg. 181	Male Branch Tee  TF5605x pg. 181	Female Branch Tee  Stainless Steel No. 5667x C5655x pg. 182	Female Branch Tee  TF5655x pg. 182
Swivel Nut Branch Tee  Stainless Steel No. 5719x C5707x pg. 182	Swivel Nut Branch Tee  TF5707xx pg. 182	Bulkhead Union Tee  Stainless Steel No. 5737x TF5725x pg. 182	Straight Thread O-Ring Branch Tee  C5715x pg. 183	Straight Thread O-Ring Branch Tee  TF5715x pg. 183	Cross  Stainless Steel No. 5967x TF5955x pg. 183	Straight Thread O-Ring  7629x pg. 183



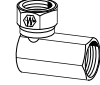



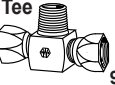
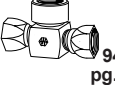









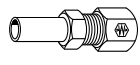
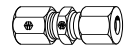
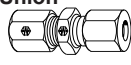
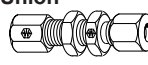
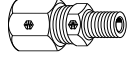
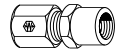

DIN/METRIC/BRITISH PIPE FITTINGS

Metric Flareless Sleeve  7165x pg. 211	Metric Flareless Nut - Light Series  ML7105x pg. 211	Metric Flareless Nut - Heavy Series  MH7105x pg. 211	Male SAE 37° to 24° Metric Tube Seat (Light)  MC5206x pg. 212	Male SAE 37° to 24° Metric Tube Seat (Heavy)  MC5208x pg. 212	Male SAE (JIC) 37° to 60° Metric Tube Seat  MC5207x pg. 212	Male SAE 37° to Male Metric Stand Pipe  MC5019x pg. 212
Sleeve 3 Piece Metric  C5165x pg. 213	Male SAE 37° to Male Metric Straight Thread Connector  MC5315x pg. 213	Female SAE 37° Swivel to Male JIS Tapered Pipe Thread  M9700x pg. 214	Male SAE 37° to Male Metric 90° Straight Thread 90° Elbow  MC5515x pg. 214	Metric Retaining Ring  M7630x pg. 214	Metric O-Ring  M7629x pg. 214	Hex Head Plug  MC3159x pg. 215
Coupling  MC3309x pg. 215	Hex Nipple  MC3069x pg. 216	Male BSPT to Male SAE 37°  MC5205x pg. 216	BSPP Female To NPTF Male Adapter  1150x pg. 216	BSPP Male To NPTF Female Adapter  1100x pg. 217	Male BSPP to Male SAE 37°  MB5315x pg. 217	Female SAE 37° Swivel to Male BSPP  M9800x pg. 217
Female SAE 37° Swivel to Male BSPP  M9600x pg. 217	Male BSPT to Male SAE 37° Elbow  MC5405x pg. 218	Male BSPP to Male SAE 37° Elbow  MB5515x pg. 218	British Retaining Ring  MB7630x pg. 218	British O-Ring  MB7629x pg. 218		

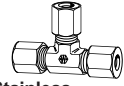
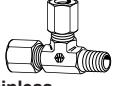
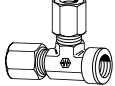
NPSM FEMALE SWIVEL ADAPTERS

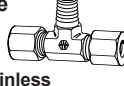
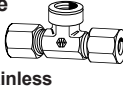

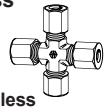











Female Pipe Swivel to Male Pipe  9205x pg. 148	Fem. SAE 37° Swivel to Male Pipe  9100x pg. 148	Fem. Pipe Sw. to Fem. Pipe  9255x pg. 149	Male Straight Thread O-Ring to Fem. Pipe Swivel  9315x pg. 149	Female Pipe Swivel to Male Pipe 45° Elbow  9355x pg. 150	Female Pipe Swivel to Female Pipe 45° Elbow  9385x pg. 150	Female 45° Flare Swivel to Male SAE 45° Elbow  9154x pg. 150
Male Straight Thread O-Ring to Fem. Pipe Sw. 45° Elbow  9365x pg. 151	Female Pipe Swivel to Male Pipe 90° Elbow  9405x pg. 151	Fem. Pipe Sw. to Male Pipe 90° Elbow - Long  9405x pg. 151	Fem. Pipe Sw. to Fem. Pipe 90° Elbow  9455x pg. 152	90° Elbow 45° Female Swivel to SAE 45°  9151x pg. 152	Male Straight Thread O-Ring to Fem. Pipe Sw. 90° Elbow  9515x pg. 152	Male Pipe Swivel to Male Pipe Rigid 90° Elbow  9435x pg. 153
Female Pipe Swivel Tee  9705x pg. 153	Fem. Pipe Sw. to Male Pipe Branch Tee  9406x pg. 153	Fem. Pipe Sw. to Fem. Pipe Branch Tee  9456x pg. 153				

FLARELESS – 7000 SERIES ERMETO®





<p>Sleeve</p>  <p>Stainless Steel No. 7165x 7176x pg. 201</p>	<p>Sleeve - For Diesel Nut</p>  <p>8165x pg. 201</p>	<p>Nut</p>  <p>Stainless Steel No. 7105x 7117x pg. 201</p>	<p>Diesel Nut</p>  <p>8112x pg. 201</p>	<p>Bulkhead Nut</p>  <p>Stainless Steel No. 7924x 7936x pg. 201</p>	<p>Cap</p>  <p>Stainless Steel No. 7129x 7141x pg. 202</p>	<p>Plug</p>  <p>Stainless Steel No. 7229x 7241x pg. 202</p>
<p>Reducer</p>  <p>Stainless Steel No. 7015x 7027x pg. 202</p>	<p>Small Hex Union</p>  <p>Stainless Steel No. 7305x 7317x pg. 202</p>	<p>Large Hex Union</p>  <p>Stainless Steel No. 7306x 7318x pg. 202</p>	<p>Bulkhead Union</p>  <p>Stainless Steel No. 7325x 7337x pg. 203</p>	<p>Male Connector</p>  <p>Stainless Steel No. 7205x 7217x pg. 203</p>	<p>Female Connector</p>  <p>Stainless Steel No. 7255x 7267x pg. 203</p>	<p>Straight Thread O-Ring Connector</p>  <p>Stainless Steel No. 7315x 7327x pg. 203</p>
<p>45° Male Elbow</p>  <p>Stainless Steel No. 7355x 7367x pg. 204</p>	<p>90° Union Elbow</p>  <p>Stainless Steel No. 7505x 7517x pg. 204</p>	<p>90° Male Elbow</p>  <p>Stainless Steel No. 7405x 7417x pg. 204</p>	<p>90° Female Elbow</p>  <p>Stainless Steel No. 7455x 7467x pg. 204</p>	<p>Straight Thread O-Ring 90° Elbow</p>  <p>Stainless Steel No. 7515x 7527x pg. 205</p>	<p>Union Tee</p>  <p>Stainless Steel No. 7705x 7717x pg. 205</p>	<p>Male Run Tee</p>  <p>Stainless Steel No. 7755x 7767x pg. 205</p>
<p>Female Run Tee</p>  <p>7805x pg. 205</p>	<p>Straight Thread O-Ring Run Tee</p>  <p>Stainless Steel No. 7716x 7728x pg. 206</p>	<p>Male Branch Tee</p>  <p>Stainless Steel No. 7605x 7617x pg. 206</p>	<p>Female Branch Tee</p>  <p>Stainless Steel No. 7655x 7667x pg. 206</p>	<p>Straight Thread O-Ring Branch Tee</p>  <p>Stainless Steel No. 7715x 7727x pg. 207</p>	<p>Cross</p>  <p>Stainless Steel No. 7955x 7967x pg. 207</p>	<p>Straight Thread O-Ring</p>  <p>7629x pg. 207</p>

NOTE: Straight Thread O-Ring Section pages 184-194.

Molded Compression Tube Fittings

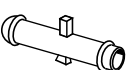
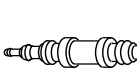
Male Connector  1568x pg. 131	Union Connector  1562x pg. 132	Bulkhead Union  1574x pg. 131	Female Connector  1566x pg. 132	Male Elbow  1569x pg. 133	Female Elbow  1570x pg. 133	Union Elbow  1565x pg. 134
Male Branch Tee  1572x pg. 134	Union Tee  1564x pg. 134	Male Run Tee  1571x pg. 135	Compression Nut  1561x pg. 135	Insert  1584x pg. 135	Cap Nut  1529x pg. 136	Bulkhead Nut  1502x pg. 136
KYNAR Check Valve  1531x pg. 136						

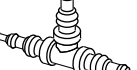
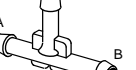
Additional Plastic Fittings

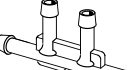
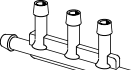
Straight Connector  pg. 137	Restrictor Connector  pg. 137	Universal Connector  pg. 137	Elbow Connector  pg. 137	Universal Tee  pg. 137	3 Way Tee  pg. 137	Y Connector  pg. 137
4 Way Tee  pg. 137	5 Way Tee  pg. 137					

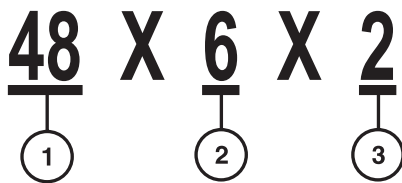

Numbering Systems

Fittings are identified by a series of numbers separated by the letter "X."

1. The number preceding the "X" is the Catalog "Base Number" and indicates the type of fitting. See Table 1 below for additional base number data (sometimes referred to as dash size).
2. The second number is the tube and/or pipe size in sixteenths of an inch. When a pipe thread for a given tube size follows the SAE standard as shown in Table 2, no other number is required. Example: 48X6 = SAE 45° Flare Male Connector-3/8" tube, 1/4" Male Pipe.
3. If the pipe size is not to the SAE standard, another "X" is added followed by the pipe size indicated in sixteenths of an inch. Example: 1/8" is equal to 2/16" or X2 suffix.

TABLE 1

Type	Example Male Connector	Example Female Connector
45° Flare	48	46
Compression	68	66
Polyline®	1268	1266
Selfalign®	681	661
Air Brake (Nylon)	1468	1466
Air Brake (Copper)	1368	1366
(JIC) Flare-Twin®	C5205	C5255
7000 Series Ermeto®	7205	7255

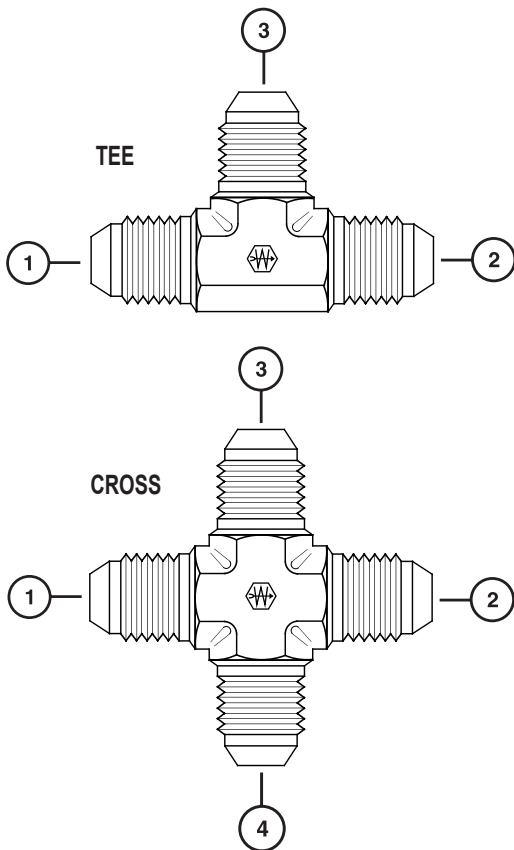

In designating tube and pipe sizes for tees and crosses that are not SAE standard, indicate the sizes in the sequence shown.

TABLE 2

Tube Size	Pipe Threads	
	Brass Fitting	Steel Fitting
X2	1/8"	1/8"
X3	3/16"	1/8"
X4	1/4"	1/8"
X5	5/16"	1/8"
X6	3/8"	1/4"
X7	7/16"	1/4"
X8	1/2"	3/8"
X10	5/8"	1/2"
X12	3/4"	3/4"
X14	7/8"	3/4"
X16	1"	1"
X20	1-1/4"	No Standard
X24	1-1/2"	No Standard
X32	2"	No Standard

Plating

Standard Boston Weatherhead Steel Pipe and Flare fittings are supplied with Zinc plate and a yellow Dichromate finish.

Steel Flareless fittings are supplied standard with the exclusive Weathercote® finish. Forged (JIC 37°) Flare-Twin fittings are designated by a prefix "C". To special order alternative plating, add prefix letter to the catalog base number. For example, a "C" prefix indicates Zinc plate (C7205X4), and a "W" prefix indicates Weathercote® (W5205X4).

Tube Fitting Selector Chart

Application

 Refer to safety information regarding tube fitting selection on page 1.

Weatherhead Fitting Types	Mini-Barb®	Polyline®	Threaded Sleeve	Pipe	Inverted Flare	SAE 45° Flare	Compression	Selfalign®	1400 Series Air Brake	1300 Series Air Brake	Push® Connect	Pipe	SAE 37° Flare-Twin®	7000 Series Ermeto®	For-Seal®	Q-CAB®	Molded Compression
Fitting Material	Brass	Brass	Brass	Brass	Brass	Brass	Brass	Brass	Brass	Brass	Brass	Steel S.S.	Steel S.S.	Steel S.S.	Steel	Brass	Nylon Poly
Tube Size (O.D. range in inches)	1/8 1/2	1/8 1/2	1/8 3/8	1/8 3/4	1/8 1	1/8 3/4	1/8 1	1/8 1	1/4 3/4	1/4 3/4	1/8 1/2	1/8 2	1/8 2	1/8 2	1/4 1-1/2	5/32 3/4	1/8 3/4
Maximum Working Pressure (psi) Depends on tubing material, O.D., wall thickness and fitting size.	135	500	500	1200	2000	2000	2000	2000	150	150	250	6000	6,000	10,000	6,000	150	50/220
Vibration (Comparative)																	
Fair																	
Good																	
Excellent																	
Tubing Types																	
Copper		E												A			
Steel																	
Aluminum		E															
Stainless Steel-Annealed															G		
Stainless Steel - 1/8-Hard															G		
Polyethylene							w/insert	w/insert									
Nylon									w/insert							E	
Polyvinyl Chloride (PVC)							w/insert	w/insert									
Bundy							B	B									
Conforms																	
SAE																	
JIC																	
UL				F	F	F	F										
ASA																	
ASME																	
Military									H								
DOT																	
Typical Use																	
Instrumentation																	
Oil-Air-Water																	
Refrigeration																	
Hydraulic Systems																	
Cooling Systems																	
Lubrication Systems																	
Air Brake																	

 Recommendation and A — Copper tubing (half or full hard) may be used E — Use brass sleeve only G — Cadmium Free Braze Ring

APPLICATION

Fitting Thread Size Comparison Chart – The male connections have (Male unified thread class 2 fit) UN-2A specification threads and the female connections have (Female unified thread class 2 fit) UN-2B specification threads. The exceptions are male and female pipe threads.

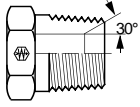
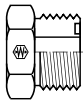
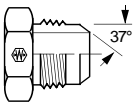
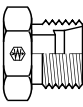
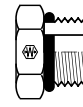
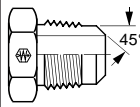
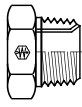
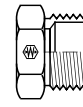
								
Size	Pipe Size	FOR-SEAL®	37° Flare Flare-Twin®	Ermeto® 7000 Series	Straight Thread O-Ring SAE	45° Flare	Inverted Flare	Compression
1/16	1/16–27	–	–	–	–	–	–	–
1/8	1/8–27	–	5/16–24	5/16–24	5/16–24	5/16–24	5/16–28	5/16–24
3/16	–	–	3/8–24	3/8–24	3/8–24	3/8–24	3/8–24	3/8–24
1/4	1/4–18	9/16–18	7/16–20	7/16–20	7/16–20	7/16–20	7/16–24	7/16–24
5/16	–	–	1/2–20	1/2–20	1/2–20	1/2–20	1/2–20	1/2–24
3/8	3/8–18	11/16–16	9/16–18	9/16–18	9/16–18	5/8–18	5/8–18	9/16–24
7/16	–	–	–	–	–	11/16–16	11/16–18	5/8–24
1/2	1/2–14	13/16–16	3/4–16	3/4–16	3/4–16	3/4–16	3/4–18	11/16–20
5/8	–	1–14	7/8–14	7/8–14	7/8–14	7/8–14	7/8–18	13/16–18
3/4	3/4–14	1-3/16–12	1-1/16–12	1-1/16–12	1-1/16–12	1-1/16–14	1-1/16–16	1–18
7/8	–	1-3/16–12	1-3/16–12	1-3/16–12	1-3/16–12	–	1-3/16–16	–
1	1–11-1/2	1-7/16–12	1-5/16–12	1-5/16–12	1-5/16–12	–	1-5/16–16	1-1/4–18
1-1/4	1-1/4–11-1/2	1-11/16–12	1-5/8–12	1-5/8–12	1-5/8–12	–	–	–
1-1/2	1-1/2–11-1/2	2–12	1-7/8–12	1-7/8–12	1-7/8–12	–	–	–
2	2–11-1/2	2-1/2–12	2-1/2–12	2-1/2–12	2-1/2–12	–	–	–

ACTUAL PIPE THREAD SIZES

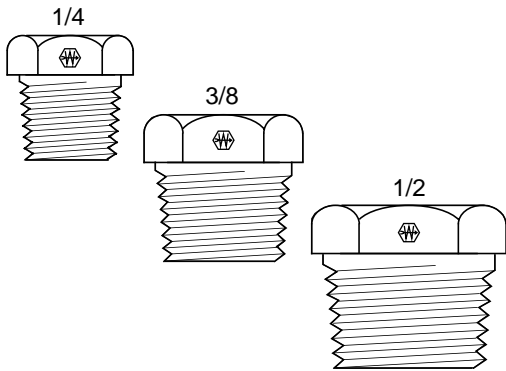

PIPE FITTINGS

The Society of Automotive Engineers in cooperation with industry set up a standard for improvement in pipe threads. This improvement is known as the Dryseal Pipe Thread. All Weatherhead pipe threads are Dryseal American Standard Tapered Pipe Threads (NPTF). The metal to metal seal is formed by contact at the thread crest and root.

Nominal pipe sizes do not agree with either the I.D., O.D., or thread sizes. To determine pipe size (up to 1-1/4") measure the diameter of the threads and subtract 1/4". For example, subtract 1/4" from a 1" thread O.D. to obtain the nominal pipe size of 3/4".

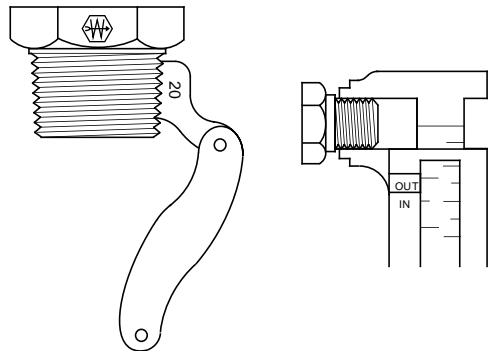

TUBE FITTINGS

There are four basic types of tube fittings; Flare, Flareless, Straight Thread O-Ring, and Flat Face O-Ring Seal (FOR-SEAL®). Tube fittings seal in two ways. Flare and Flareless fittings use metal to metal contact joints. Straight Thread O-Ring and Flat Face O-Ring fittings use a rubber O-Ring. Where extreme vibration is present, use Flareless, Straight Thread or Flat Face O-Ring Seal fittings.

SIZING: For accuracy, it is recommended the male thread be measured. Measure the outside diameter. For our example use 7/16". Next measure the threads per inch, use 20. Our fitting size measures 7/16-20. Refer to the thread chart above for appropriate tube size and illustration.

Identifying metric, or non-USA, threaded connections is similar to identifying the connections that have been commonly used in the United States. The following text covers how to identify the different styles of metric connections offered by Weatherhead.

THREADS - The thread forms and their corresponding specifications listed below are used on all of the metric styles of connections which will be discussed later. These cover the basic forms of the threads but not the style of connection.

Thread Type	Specifications
British Parallel Pipe Threads	BS 2779, ISO/R 228
British Taper Pipe Threads	BS 21, ISO/R 7
Metric Parallel Threads	DIN 3852, ISO/R 6149
Metric Taper Threads	DIN 3852

NOTE: BS—British Standards Institution
 ISO—International Standards Organization
 DIN—Deutsche Industrie Norme

To identify metric connections, you will need instruments that can accurately measure thread inside and outside diameters, thread pitch and fitting seat angles. The TA-1002 Thread Measuring Guide and Tool Kit is a basic kit that will help you in identifying most of the connections you will be encountering on imported equipment.

PARALLEL and TAPERED THREADS

Parallel Threads ('G')

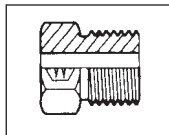

Figure 1.

Tapered Threads ('R')

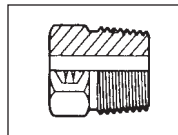

Figure 2.

The first step in identifying thread forms is to determine if the thread is parallel or tapered. Parallel threads are not used for sealing fluids. Sealing is achieved by an elastomeric o-ring, metal seal, machined ring into the hex itself or a seat machined into the end of the fitting. This style is similar to straight thread o-ring port connections where the threads are used for retention of the sealing method against a machine port. Parallel threads can be determined by laying a straight edge along the threads. If the threads are parallel to the center line of the fitting, then the fitting has parallel threads. See Figure 1.

Tapered threads seat by the interference caused by the male and female threads. These threads create a pressure-tight joint by metal deformation when they are tightened. Sealants on the threads are commonly used in this style of connection. Laying a straight edge on the threads, compare this line with the center line of the fitting. If this line tapers slightly away from the center line, then the threads are tapered. See Figure 2.

BRITISH PIPE THREADS

There are two forms of British Standard Pipe Threads that are used in the world today. They are BSPP (British Standard Pipe Parallel) and BSPT (British Standard Pipe Tapered). The BSPT male thread mates with the female BSPT thread similar to an NPTF connection. The 30° BSPP male adapters connect to a female BSPP thread with a 30° cone. This style is comparable to an NPSM swivel style. These threads are almost identical to the NPTF Pipe Thread except for the flank angle. This angle is 55° versus 60° on the NPTF. See Figure 3. Because of this difference, the two forms are **NOT** interchangeable.

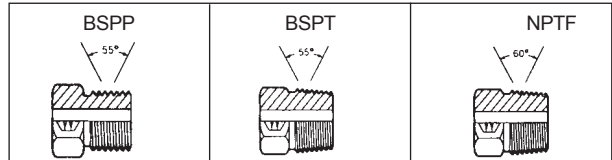

Figure 3.

Identifying BSP threads starts with determining if it is a parallel or tapered thread. Next, referencing Figure 4, measure the lead thread diameter. Compare this measurement to the listed dimensions to determine size. If instruments are not available to measure this, you can compare it end-to-end with a known NPTF thread to approximately arrive at the nominal BSP size. Finally, measure the pitch and compare it to the chart on Figure 4a to complete the identification. These dimensions will be the same for both BSPP and BSPT.

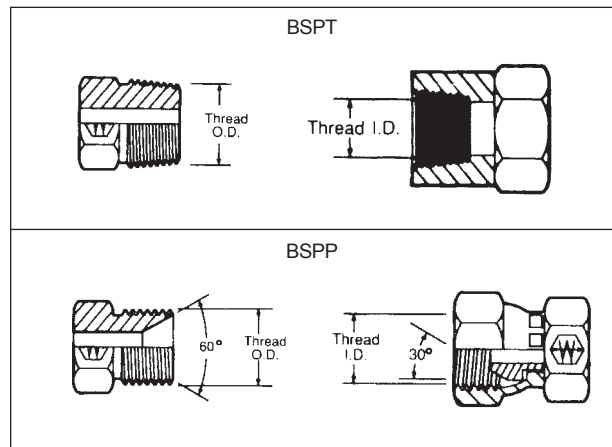

Figure 4.

BSP Thread Size	1/8-28	1/4-19	3/8-19	1/2-14	5/8-14	3/4-14	1-11	1-1/4-11	1-1/2-11	2-11
Male Thread Diameter	9.72 (.375)	13.16 (.518)	16.66 (.656)	20.96 (.825)	22.91 (.902)	26.44 (1.041)	33.25 (1.309)	41.91 (1.650)	47.80 (1.882)	59.51 2.347
Female Thread Diameter	8.73 (.343)	11.66 (.459)	15.37 (.605)	18.90 (.744)	20.85 (.821)	24.38 (.960)	30.61 (1.205)	39.24 (1.545)	45.24 (1.781)	55.94 2.242
Pitch	.91 (.036)	1.34 (.053)	1.34 (.053)	1.81 (.071)	1.81 (.071)	1.81 (.071)	2.31 (.091)	2.31 (.091)	2.31 (.091)	2.31 (.091)

**BSPP & BSPT
Thread Chart**

Figure 4a. Dimension Note: MM(IN)

See page 224 for Thread Measuring Kits.

METRIC THREADS

Metric threads are similar to inch-sized threads except for the sizing which is based on standard metric units. Identifying metric threads starts with determining if it is a parallel or tapered thread. Next, measure the thread diameter. Compare this measurement to the dimensions listed in Figure 5 to determine size. Finally, measure the pitch and compare to chart. These dimensions will be common for both parallel and tapered threads.

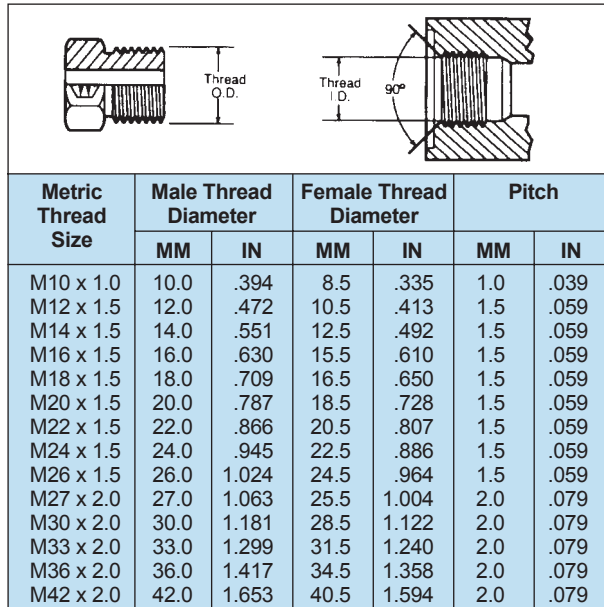

Figure 5.

METRIC FLARELESS CONNECTIONS—Din 3901/3902L, 3901/3902S

The most popular metric flareless, or bite-type, fitting style is the 24° Metric Tube Seat. This style incorporates a tapered seat in the fitting body with a bite-type sleeve, or ferrule, for the connection. When the nut is tightened, the tapered seat forces the sleeve into the tube creating a positive seal. This style of connection is available in both a Light and Heavy series and is designed for medium and high pressure applications respectively. The two series have different parallel thread sizes in relationship to the nominal tube outside diameter, but share a common sleeve. This style can be identified by the combination of the 24° internal seat and a male metric parallel thread. The series can be determined by measuring the seat counterbore, which is the approximate tube outside diameter, and comparing it to the thread size. Compare these dimensions to those shown in Figure 6 to determine the series. The nominal sleeve size is taken directly from the tube outside diameter dimension.

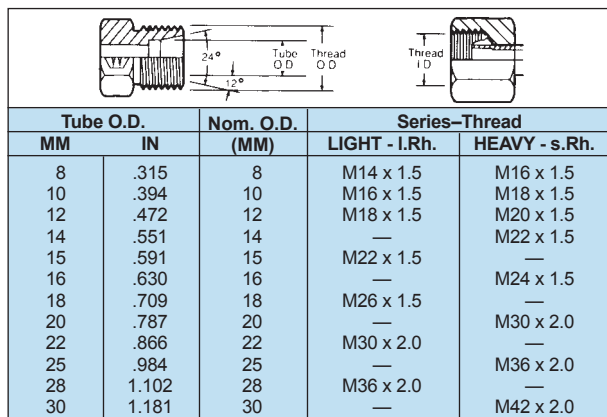

Figure 6.

METRIC 60° TUBE SEAT—DIN 7631

This series combines an internal 60° seat with parallel metric Light series threads. Mating with female metric swivel fittings with a globe seal made to DIN 3863L, this connection provides a metal to metal seal when tightened. This style can be identified by the internal 60° seat on the male metric threaded portion. Reference Figure 7 for thread information.

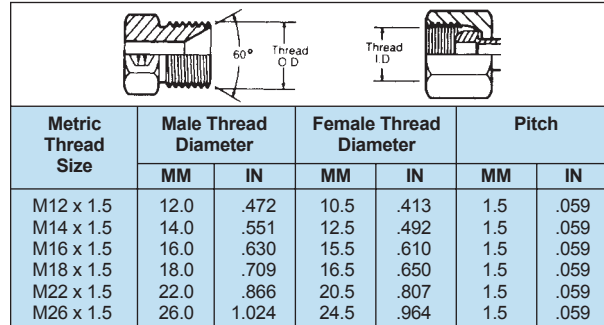

Figure 7.

JAPANESE METRIC 30° FLARE

The Japanese 30° flare style is similar to the 37° JIC flare connection except for two things. The seat angle is 30° and threads are metric straight threads. This fitting is often referred to as a 'Komatsu' style connection. To identify this style, first verify the seat angle is 30°. Next establish the metric thread size by measuring the thread outside diameter. Compare this dimension to those shown in Figure 8. The threads in this series will conform to Japanese Industrial Standard (JIS) B 0207.

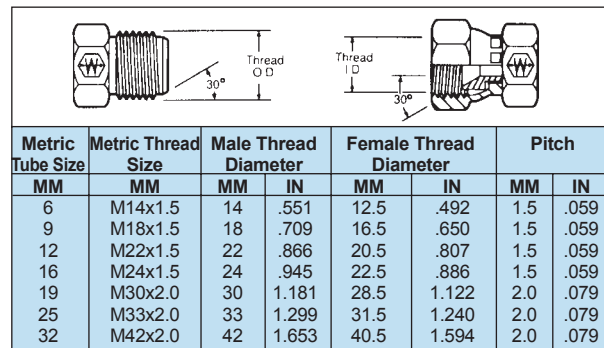

Figure 8.

JAPANESE 30° FLARE (JIS)

Similar to BSPP and a 30° seat. The seal is made when contact is made between the male and female flares, with the threads retaining the connection. The JIS 30° flare is similar to the 37° flare connection. To determine the difference between the JIS 30° flare and the JIC 37° flare, carefully measure the seat angle. The threads in this series conform to Japanese Industrial Standard (JIS) B 0202.

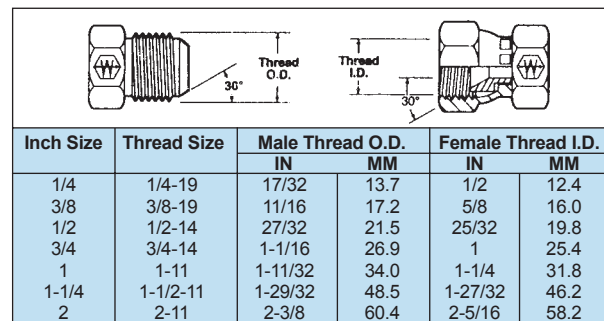

Figure 9.

See page 224 for Thread Measuring Kits.

 Refer to safety information regarding tubing selection on page 1.

To select tubing for a particular installation, two factors must be determined...

- 1.) **tubing type** - material and construction and
- 2.) **size** - inside diameter (I.D.) and wall thickness. Information listed below will aid in your tubing selection.

TUBING TYPES

Commercial tubing is available in a wide variety of materials, types of construction and quality. Each is best suited for certain specific applications.

STEEL TUBING - Seamless SAE 1010 fully annealed and SAE welded types suitable for bending and flaring. This is the only tubing material approved without restrictions by SAE standards.

STAINLESS STEEL TUBING - Both seamless *18-8 fully annealed and welded types suitable for bending and flaring. Stainless steel tubing is recommended for use with very high pressures and where large diameter tubing is required. It is also suited for many applications where corrosion is a problem.

* (302, 303 and/or 304)

ALUMINUM TUBING - Seamless annealed is approved by SAE for low pressure applications.

COPPER TUBING - Seamless fully annealed coils and fully annealed or quarter-hard straight lengths can be used for systems that do not use petroleum based fluids (copper acts as an oil-oxidation catalyst, causing sludge). Copper also tends to work harden when flared or bent and has poor resistance to vibration. Therefore, the use of copper tubing is limited to low-pressure stationary applications and air circuits.

SPECIAL ALLOY TUBING - May be required for specific corrosion problems. Information on these applications can be obtained from your tubing supplier or from tubing manufacturers.

TUBING SIZE

The two variables in tubing size are the inside diameter (ID) and the wall thickness. Each of these is dependent upon a number of factors.

INSIDE DIAMETER - The tubing I.D. will determine the flow and velocity of the fluid in the system.

Flow is the volume of fluid that is to be moved through the line to perform a given job within a specified time. Flow rate is expressed in gallons per minute (gpm).

Velocity is the rate of speed at which the fluid passes through the line. It is expressed in feet per second (fps). With a given flow rate, the velocity will increase as the inside diameter of the tubing decreases.

To determine the appropriate tubing I.D. for specific flow rate and velocity, refer to the Velocity vs. Flow chart on page 21.

WALL THICKNESS - The required wall thickness of the tubing depends upon operating pressure, safety factor, temperatures, and tubing material.

Operating Pressure is the pressure of the fluid in the system. It is expressed in pounds per square inch (psi).

Safety Factor is a multiplier applied to the wall thickness that compensates for additional mechanical strains and hydraulic shocks to which the tubing may be subjected during operation.

To determine the appropriate wall thickness, refer to the data on pages 22 and 23.

PRESSURE DROP

Total pressure supplied to a line must equal usable pressure (or output) plus the pressure that is lost through fluid transmission, which is referred to as pressure drop. These pressure drops cause loss of energy and should be kept to a minimum. Elements which cause pressure drop in the transmission of fluids include sudden enlargements or contractions, bends, fittings and valves.

Mathematical analysis of pressure drop, although possible, is not precise because of the interrelationship of factors such as fluid velocity, density, flow area and friction coefficients. Therefore, to obtain optimum efficiency, the system (or the questionable portions of the system) should be mocked-up to obtain empirical pressure drop data.

 Refer to safety information regarding tubing selection on page 1.

Following is a typical problem that illustrates, step by step, the procedure for determining tube size.

Select 1010 steel tubing with the appropriate I.D. and wall thickness for the following conditions:

- Flow — 5 gpm
- Velocity — not to exceed 10 fps
- Pressure — 2000 psi
- Safety Factor — 4:1

SOLUTION:

1. Using the Flow/Velocity chart on Page 21, follow the horizontal flow line (5 gpm) until it intersects the vertical velocity line (10fps). From this point, follow the diagonal line upward to get the required tube I.D. (.444). If the horizontal flow line and the vertical velocity line intersect between two diagonal lines, normally the larger inside diameter would be selected since it would mean less velocity.
2. Refer to the chart of Standard Size Hydraulic Tubing, at right. Note that .444 I.D. tubing is not listed. If you want to use standard tubing, select one with a larger I.D. Do not select a smaller size since this would increase the velocity to over the 10 fps limit. Therefore, by going to the next largest size, you would select the 5/8" O.D. tubing having an I.D. of .459 and a wall thickness of .083.
3. To determine whether this tubing will meet the pressure and safety factor requirements, refer to the Recommended Wall Thickness data on pages 24 and 25. For 5/8" O.D. tubing at 2000 psi, the chart for 1010 steel indicates that the minimum wall thickness with a safety factor of 4:1 is .04545. Since you have selected a tubing with a .083 wall, this would easily fulfill the requirements. However, for savings on weight and cost, you can select another tubing with a thinner wall that will still meet the performance requirements. Therefore, refer again to the chart on standard size tubing and select a tubing with a wall thickness closer to the minimum requirements. This would be the 5/8" O.D. tubing with a .527 I.D. and a .049 wall. This tubing will handle the pressure requirements of 2000 psi with a safety factor of 4:1, and also provides the required flow while keeping the velocity within the 10 fps limitation.

STANDARD SIZE HYDRAULIC TUBING

Tube O.D.	Tube I.D.	Wall	Tube O.D.	Tube I.D.	Wall	
1/8"	.055	.035	3/4"	.584	.083	
	.061	.032		.606	.072	
	.065	.030		.620	.065	
	.069	.028		.634	.058	
3/16"	.117	.035	7/8"	.652	.049	
	.123	.032		.680	.035	
	.127	.030		.657	.109	
1/4"	.120	.065	1"	.685	.095	
	.134	.058		.709	.083	
	.152	.049		.731	.072	
	.166	.042		.745	.065	
	.180	.035		.759	.058	
	.190	.030		.777	.049	
5/16"	.182	.065	1-1/4"	.982	.134	
	.196	.058		1.010	.120	
	.214	.049		1.032	.109	
	.228	.042		1.060	.095	
	.242	.035		1.084	.083	
	.248	.032		1.106	.072	
	3/8"	.245		.065	1.120	.065
		.259		.058	1.134	.058
.277		.049	1.152	.049		
.291		.042	1.232	.134		
.305		.035	1.260	.120		
.311		.032	1.282	.109		
1/2"		.310	.095	1.310	.095	
		.334	.083	1.334	.083	
		.358	.072	1.356	.072	
		.370	.065	1.370	.065	
	.384	.058	1.732	.134		
	.402	.049	1.760	.120		
	.416	.042	1.782	.109		
	.430	.035	1.810	.095		
	.436	.032	1.834	.083		
	5/8"	.435	.095	1.856	.072	
.459		.083	1.870	.065		
.481		.072	2"	1.732	.134	
.495		.065		1.760	.120	
.509		.058		1.782	.109	
.527		.049		1.810	.095	
.541		.042		1.834	.083	
.555		.035		3/4"	1.856	.072
3/4"	.532	.109	1.870		.065	
	.560	.095				

Tubing Selection

Application

TO FIND REQUIRED TUBE I.D.

Flow—20 gpm • Velocity—9 fps
Follow horizontal flow line (20 gpm) until it intersects vertical velocity line (9 fps). From this point follow diagonal line to get required Tube I.D.—(.944).

TO FIND PERMISSIBLE FLOW

Velocity—15 fps • Tube I.D.—.495
Follow vertical velocity line (15 fps) until it intersects diagonal line representing .495 tube I.D. Then project this point horizontally to get the permissible flow—(9 gpm).

TO FIND VELOCITY OF FLUID IN SYSTEM

Flow—6 gpm • Tube I.D.—.694
Follow horizontal flow line (6 gpm) until it intersects diagonal line representing .694 tube I.D. Then project this point vertically downward to get the velocity of fluid—(5 fps).

APPLICATION

FLOW/VELOCITY CHART

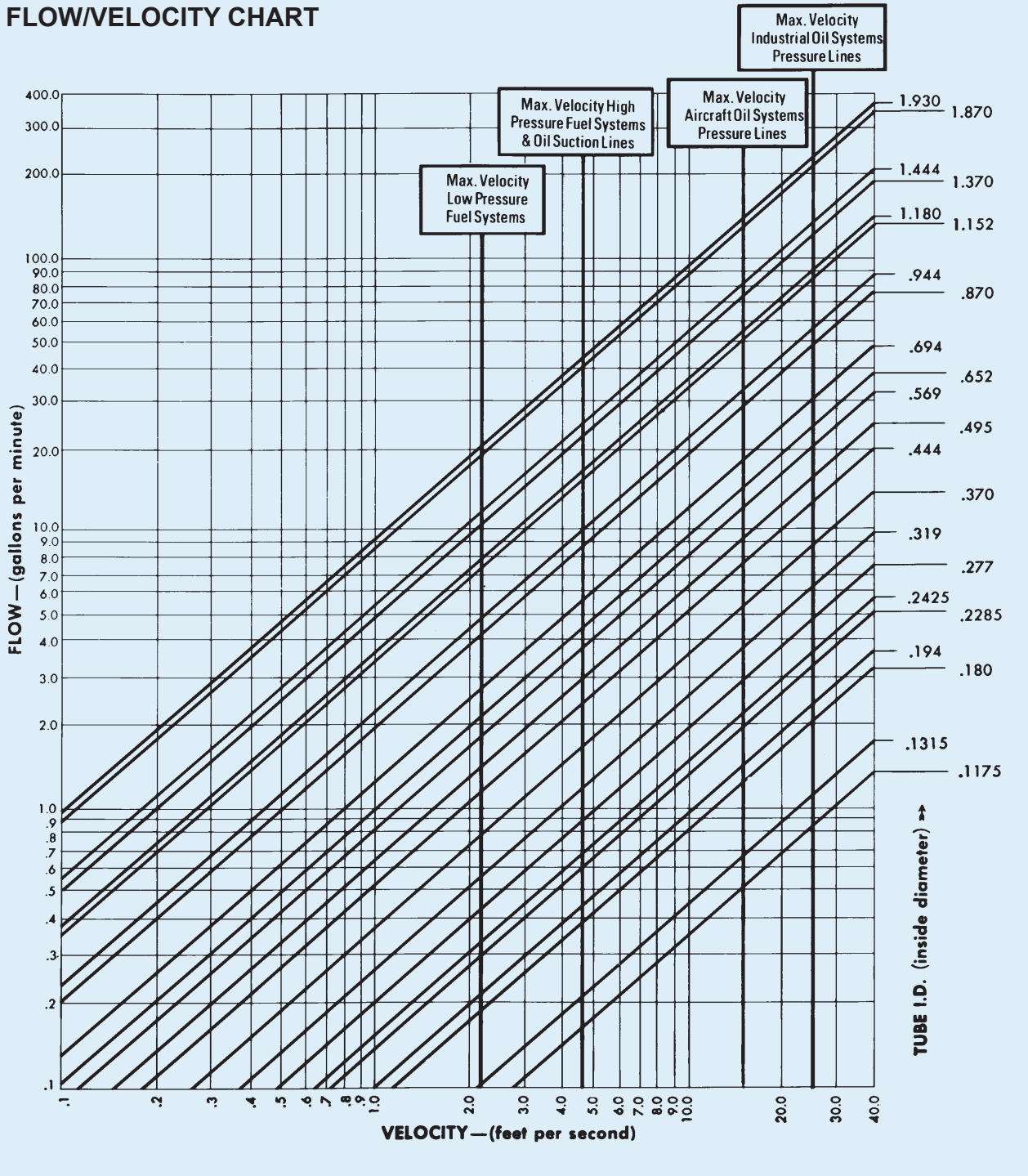

 Refer to safety information regarding tubing selection on page 1.

With the following Recommended Wall Thickness tables the tubing wall can be selected that is best suited for a particular application. The data given in these tables are raw figures based on the equation –

$$t = \frac{Dp(FS)}{2S}$$

- t–wall thickness (inches)
- D–O.D. of tube (inches)
- p–pressure (psi)
- FS–Safety Factor
- S–tensile strength of tubing material

Therefore, many of the wall thicknesses given in these tables are not found on standard tubing, but serve to establish the minimum wall required.

SAFETY FACTOR – The standard safety factors indicate three grades of severity of service:

- 4:1** –mechanical and hydraulic shocks not excessive
- 6:1** –considerable mechanical strain and hydraulic shock
- 8:1** –hazardous applications with severe service conditions

RECOMMENDED WALL THICKNESS TABLES

1010 STEEL Based on 55,000#/in. ² Strength (F S=4)					
TUBE O.D.	working pressure (psi)				
	1,000	2,000	3,000	4,000	5,000
1/8	.00455	.00909	.01364	.01818	.02273
3/16	.00682	.01364	.02045	.02727	.03409
1/4	.00909	.01818	.02727	.03636	.04545
5/16	.01136	.02273	.03409	.04545	.05682
3/8	.01364	.02727	.04091	.05455	.06818
1/2	.01818	.03636	.05455	.07273	.09091
5/8	.02273	.04545	.06818	.09091	.11364
3/4	.02727	.05455	.08182	.10909	.13636
7/8	.03182	.06364	.09545	.12727	.15909
1	.03636	.07273	.10909	.14545	.18182
1-1/4	.04545	.09091	.13636	.18182	.22727
1-1/2	.05455	.10909	.16364	.21818	.27273
2	.07273	.14545	.21818	.29091	.36364

4130 STEEL Based on 90,000#/in. ² Strength (F S=4)					
TUBE O.D.	working pressure (psi)				
	1,000	2,000	3,000	4,000	5,000
1/8	.00278	.00556	.00833	.01111	.01389
3/16	.00417	.00833	.01250	.01667	.02083
1/4	.00556	.01111	.01667	.02222	.02778
5/16	.00694	.01389	.02083	.02778	.03472
3/8	.00833	.01667	.02499	.03333	.04167
1/2	.01111	.02222	.03333	.04444	.05556
5/8	.01389	.27778	.04167	.05556	.06944
3/4	.01667	.03333	.04999	.06667	.08333
7/8	.01944	.03889	.05833	.07778	.09722
1	.02222	.04444	.06667	.08889	.11111
1-1/4	.02778	.05556	.08333	.11111	.13889
1-1/2	.03333	.06667	.09999	.13333	.16667
2	.04444	.08889	.13333	.17778	.22222

The wall thickness shown in these tables are based on ultimate strength of material and a safety factor of 4:1.

To obtain the recommended wall for a specific pressure based on a safety factor of 6:1, multiply the wall thickness indicated in the table by 1.5. For a safety factor of 8:1, multiply by 2:

TEMPERATURE – The wall thickness found by using these tables can be corrected for temperature by multiplying the wall thickness by the appropriate correction factor given in the chart below. The table is based on strength reduction due to increased temperature.

RECOMMENDED WALL THICKNESS TABLES

Temperature	1010 Steel	Stainless Steel	Copper	Aluminum
+100F.	1.00	1.00	1.00	1.00
+200F.	1.00	1.00	1.08	1.00
+300F.	1.00	1.00	1.22	1.08
+400F.	1.00	1.00	2.30	1.41
+500F.	1.00	1.00	–	2.10
+600F.	1.00	1.00	–	–
+700F.	1.00	1.00	–	–
+800F.	1.08	1.07	–	–
+900F.	1.32	1.13	–	–
+1000F.	1.66	1.22	–	–

1020 STEEL Based on 65,000#/in. ² Strength (F S=4)					
TUBE O.D.	working pressure (psi)				
	1,000	2,000	3,000	4,000	5,000
1/8	.00385	.00790	.01154	.01538	.01923
3/16	.00577	.01154	.01731	.02308	.02885
1/4	.00769	.01538	.02308	.03077	.03846
5/16	.00962	.01923	.02885	.03846	.04808
3/8	.01154	.02308	.03462	.04615	.05769
1/2	.01538	.03077	.04615	.06154	.07692
5/8	.01923	.03846	.05769	.07692	.09615
3/4	.02308	.04615	.06923	.09231	.11538
7/8	.02692	.05385	.08077	.10769	.13462
1	.03077	.06154	.09231	.12308	.15385
1-1/4	.03846	.07692	.11538	.15385	.19231
1-1/2	.04615	.09231	.13846	.18462	.23077
2	.06154	.12308	.18462	.24615	.30769

BUNDYWELD Based on 42,000#/in. ² Strength (F S=4)					
TUBE O.D.	working pressure (psi)				
	1,000	2,000	3,000	4,000	5,000
1/8	.00595	.01190	.01786	.02381	.02976
3/16	.00893	.01786	.02679	.03571	.04464
1/4	.01190	.02381	.03571	.04762	.05952
5/16	.01488	.02976	.04464	.05952	.07440
3/8	.01786	.03571	.05357	.07143	.08929
1/2	.02381	.04762	.07143	.09524	.11905
5/8	.02976	.05952	.08929	.11905	.14881
3/4					
1					
1-1/4					
1-1/2					
2					

Tubing Selection

Application

 Refer to safety information regarding tubing selection on page 1.

APPLICATION

TUBE O.D.	STAINLESS STEEL (304) ANNEALED BASED ON 75,000#/IN. ² STRENGTH (F.S. -4)					STAINLESS STEEL (304) ANNEALED BASED ON 105,000#/IN. ² STRENGTH (F.S. -4)				
	working pressure (psi)					working pressure (psi)				
	1,000	2,000	3,000	4,000	5,000	1,000	2,000	3,000	4,000	5,000
1/8	.00333	.00666	.00999	.01333	.01666	.00238	.00476	.00714	.00952	.01190
3/16	.00499	.00999	.01498	.01999	.02499	.00357	.00714	.01071	.01429	.01786
1/4	.00666	.01332	.01998	.02667	.03333	.00476	.00952	.01429	.01905	.02381
5/16	.00833	.01665	.02497	.03333	.04165	.00595	.01190	.01786	.02381	.02976
3/8	.0099	.01998	.02997	.03999	.04998	.00714	.01429	.02143	.02857	.03571
1/2	.01332	.02664	.03996	.05333	.06664	.00957	.01904	.02857	.03810	.04762
5/8	.01665	.03333	.04995	.06666	.08330	.01190	.02381	.03571	.04762	.05952
3/4	.01998	.03996	.05994	.07999	.09996	.01429	.02857	.04286	.05714	.07143
7/8	.02331	.04662	.06996	.09333	.11662	.01667	.03333	.05000	.06666	.08333
1	.02664	.05328	.07992	.10666	.13328	.01904	.03810	.05714	.07619	.09524
1-1/4	.03333	.06666	.09999	.13333	.16666	.02381	.04762	.07143	.09524	.11905
1-1/2	.03996	.07992	.11988	.15999	.19992	.02857	.05714	.08371	.11429	.14286
2	.05328	.10656	.15984	.21333	.26666	.03810	.07619	.11428	.15238	.19048

TUBE O.D.	ANNEALED COPPER BASED ON 30,000#/IN. ² STRENGTH (F.S. -4)					COPPER (UNS C12200 LIGHT DRAWN) BASED ON 40,000#/IN. ² STRENGTH (F.S. -4)				
	working pressure (psi)					working pressure (psi)				
	1,000	2,000	3,000	4,000	5,000	1,000	2,000	3,000	4,000	5,000
1/8	.00833	.01667	.02500	.03333	.04167	.00625	.01250	.01875	.02500	.03125
3/16	.01250	.02499	.03750	.04999	.06250	.00938	.01875	.02812	.03750	.04688
1/4	.01667	.03333	.05000	.06666	.08333	.01250	.02500	.03750	.05000	.06250
5/16	.02083	.04167	.06250	.08333	.10417	.01562	.03125	.04688	.06250	.07812
3/8	.02499	.04999	.07500	.09999	.12499	.01875	.03750	.05625	.07500	.09375
1/2	.03333	.06667	.10000	.13333	.16667	.02500	.05000	.07500	.10000	.12500
5/8	.04167	.08333	.12500	.16666	.20883	.03125	.06250	.09375	.12500	.15625
3/4	.04999	.09999	.15000	.19999	.24999	.03750	.07500	.11250	.15000	.18750
7/8	.05833	.11667	.17500	.23333	.29166	.04375	.08750	.13125	.17500	.21875
1	.06667	.13333	.20000	.26666	.33333	.05000	.10000	.15000	.20000	.25000
1-1/4	.08333	.16667	.25000	.33333	.41667	.06250	.12500	.18750	.25000	.31250
1-1/2	.09999	.19999	.30000	.39999	.49999	.07500	.15000	.22500	.30000	.37500
2	.13333	.26667	.40000	.53333	.66667	.10000	.20000	.30000	.40000	.50000

TUBE O.D.	ALUMINUM 3003 (H-14) BASED ON 20,000#/IN. ² STRENGTH (F.S. -4)					ALUMINUM 5052 (H-32) BASED ON 31,000#/IN. ² STRENGTH (F.S. -4)				
	working pressure (psi)					working pressure (psi)				
	1,000	2,000	3,000	4,000	5,000	1,000	2,000	3,000	4,000	5,000
1/8	.01250	.02500	.3750	.05000		.00806	.01613	.02419	.03226	.04032
3/16	.01875	.03750	.05650	.07500		.01210	.02419	.03629	.04839	.06048
1/4	.02500	.05000	.07500	.10000		.01613	.03226	.04839	.06452	.08065
5/16	.03125	.06250	.09375	.12500		.02016	.04032	.06048	.08065	.10081
3/8	.03750	.07500	.11250	.15000		.02419	.04839	.07258	.09677	.12097
1/2	.05000	.10000	.15000	.20000		.03227	.06452	.09677	.12903	.16129
5/8	.06250	.12500	.18750	.25000		.04032	.08065	.12097	.16129	.20161
3/4	.07500	.15000	.22500	.30000		.04839	.09677	.14516	.19355	.24194
7/8	.08750	.17500	.26250	.35000		.05645	.11290	.16935	.22581	.28226
1	.10000	.20000	.30000	.40000		.06452	.12903	.19355	.25806	.32258
1-1/4	.12500	.25000	.37500	.50000		.08065	.16129	.24194	.32258	.40323
1-1/2	.15000	.30000	.45000	.60000		.09677	.19355	.29032	.38710	.48387
2	.20000	.40000	.60000	.80000		.12903	.25806	.38710	.51613	.64516

TUBE O.D.	CUPRO-NICKEL 30% BASED ON 52,000#/IN. ² STRENGTH (F.S. -4)				
	working pressure (psi)				
	1,000	2,000	3,000	4,000	5,000
1/8	.00481	.00962	.01442	.01923	.02404
3/16	.00721	.01442	.02163	.02885	.03606
1/4	.00962	.01923	.02885	.03846	.04808
5/16	.01202	.02404	.03606	.04808	.06010
3/8	.01442	.02885	.04327	.05769	.07212
1/2	.01923	.03846	.05769	.07692	.09615
5/8	.02404	.04808	.07212	.09615	.12019
3/4	.02885	.05769	.08654	.11538	.14423
7/8	.03365	.06731	.10096	.13462	.16827
1	.03846	.07692	.11538	.15385	.19231
1-1/4	.04808	.09615	.14423	.19231	.24038
1-1/2	.05769	.11538	.17308	.23077	.28846
2	.07692	.15385	.23077	.30769	.38462

 **SHADED AREAS**

Tubing wall thickness listed in the shaded areas are generally either too light or too heavy for practical applications, and are listed only to provide data for accurate computation.

 Refer to safety information regarding tubing selection on page 1.

These tables provide data on required wall thickness for various sizes and pressures, and when to use flared or flareless fittings. Although heavier wall tubing can be ordered for higher operating pressures, only standard size hydraulic tubing is listed in these tables.

High temperature effects are not considered in these tables.

1010 STEEL TUBING WALL THICKNESS

TUBE O.D.	4:1 SAFETY FACTOR					6:1 SAFETY FACTOR					8:1 SAFETY FACTOR				
	working pressure (psi)					working pressure (psi)					working pressure (psi)				
	1,000	2,000	3,000	4,000	5,000	1,000	2,000	3,000	4,000	5,000	1,000	2,000	3,000	4,000	5,000
1/8	.028	.028	.028	.028	.028	.028	.028	.028	.028	.035	.028	.028	.028	.035	-
3/16	.030	.030	.030	.030	.035	.030	.030	.030	-	-	.030	.030	-	-	-
1/4	.030	.030	.030	.042	.049	.030	.030	.042	.058	-	.030	.035	.058	-	-
5/16	.032	.032	.035	.049	.058	.032	.032	.058	.065	-	.032	.049	.065	-	-
3/8	.032	.032	.042	.058	-	.032	.042	.058	-	-	.032	.058	-	-	-
1/2	.032	.042	.058	.072	-	.032	.058	.083	-	-	.042	.072	-	-	-
5/8	.035	.049	.072	.095	-	.035	.072	-	-	-	.049	.095	-	-	-
3/4	.035	.058	.083	.109	-	.049	.083	-	-	-	.058	.109	-	-	-
7/8	.049	.065	.095	-	-	.049	.095	-	-	-	.065	-	-	-	-
1	.049	.072	.109	-	-	.058	.109	-	-	-	.072	-	-	-	-
1-1/4	.049	.095	-	-	-	.072	-	-	-	-	.095	-	-	-	-
1-1/2	.065	.109	-	-	-	.083	-	-	-	-	.109	-	-	-	-
2	.072	-	-	-	-	.109	-	-	-	-	-	-	-	-	-

1020 STEEL TUBING WALL THICKNESS

TUBE O.D.	4:1 SAFETY FACTOR					6:1 SAFETY FACTOR					8:1 SAFETY FACTOR				
	working pressure (psi)					working pressure (psi)					working pressure (psi)				
	1,000	2,000	3,000	4,000	5,000	1,000	2,000	3,000	4,000	5,000	1,000	2,000	3,000	4,000	5,000
1/8	.028	.028	.028	.028	.028	.028	.028	.028	.028	.030	.028	.028	.028	.030	-
3/16	.030	.030	.030	.030	.030	.030	.030	.030	.035	-	.030	.030	.035	-	-
1/4	.030	.030	.030	.030	.042	.030	.030	.035	.049	.058	.030	.030	.049	-	-
5/16	.032	.032	.032	.042	.049	.032	.032	.042	.058	-	.032	.042	.058	-	-
3/8	.032	.032	.035	.049	.058	.032	.035	.058	.065	-	.032	.049	-	-	-
1/2	.032	.032	.049	.065	.083	.032	.049	.072	-	-	.032	.065	-	-	-
5/8	.035	.042	.058	.083	-	.035	.058	.095	-	-	.042	.083	-	-	-
3/4	.035	.049	.072	.095	-	.035	.072	.109	-	-	.049	.095	-	-	-
7/8	.049	.058	.083	-	-	.049	.083	-	-	-	.058	.109	-	-	-
1	.049	.065	.095	-	-	.049	.095	-	-	-	.065	-	-	-	-
1-1/4	.049	.083	.120	-	-	.058	.120	-	-	-	.083	-	-	-	-
1-1/2	.065	.095	-	-	-	.072	-	-	-	-	.095	-	-	-	-
2	.065	-	-	-	-	.095	-	-	-	-	.134	-	-	-	-

-  Both SAE 37° SINGLE FLARE FLARE-TWIN or ERMETO® flareless recommended.
-  ERMETO® flareless only.

NOTE: Only Weatherhead Ermeto flareless fittings can be used with high pressure, heavy wall tubing which is impractical to flare.

 Refer to safety information regarding tubing selection on page 1.

These tables provide data on required wall thickness for various sizes and pressures, and when to use flared or flareless fittings. Although heavier wall tubing can be ordered for higher operating pressures, only standard size hydraulic tubing is listed in these tables.

High temperature effects are not considered in these tables.

STAINLESS STEEL (304) ANNEALED TUBING WALL THICKNESS

TUBE O.D.	4:1 SAFETY FACTOR					6:1 SAFETY FACTOR					8:1 SAFETY FACTOR				
	working pressure (psi)					working pressure (psi)					working pressure (psi)				
	1,000	2,000	3,000	4,000	5,000	1,000	2,000	3,000	4,000	5,000	1,000	2,000	3,000	4,000	5,000
1/8	.028	.028	.028	.028	.028	.028	.028	.028	.028	.035	.028	.028	.028	.028	.035
3/16	.030	.030	.030	.030	.030	.030	.030	.030	.030	.035	.030	.030	.030	.035	—
1/4	.030	.030	.030	.030	.035	.030	.030	.030	.042	.058	.030	.030	.035	.058	.065
5/16	.032	.032	.032	.035	.042	.032	.032	.035	.058	.065	.032	.032	.049	.065	—
3/8	.032	.032	.032	.042	.058	.032	.042	.065	.083	—	.032	.042	.058	—	—
1/2	.032	.032	.042	.058	.072	.032	.042	.065	.083	—	.032	.058	.083	—	—
5/8	.035	.035	.058	.072	.083	.035	.058	.083	.095	—	.035	.065	—	—	—
3/4	.035	.049	.065	.083	.109	.035	.065	.095	—	—	.049	.083	—	—	—
7/8	.049	.049	.072	.095	—	.049	.072	.109	—	—	.049	.095	—	—	—
1	.049	.058	.083	.109	—	.049	.083	.120	—	—	.058	.109	—	—	—
1-1/4	.049	.072	.109	—	—	.058	.109	—	—	—	.065	.134	—	—	—
1-1/2	.065	.083	.120	—	—	.065	.120	—	—	—	.083	—	—	—	—
2	.065	.109	—	—	—	.083	—	—	—	—	.109	—	—	—	—

STAINLESS STEEL (304) 1/8 HARD TUBING WALL THICKNESS

TUBE O.D.	4:1 SAFETY FACTOR					6:1 SAFETY FACTOR					8:1 SAFETY FACTOR				
	working pressure (psi)					working pressure (psi)					working pressure (psi)				
	1,000	2,000	3,000	4,000	5,000	1,000	2,000	3,000	4,000	5,000	1,000	2,000	3,000	4,000	5,000
1/8	.028	.028	.028	.028	.028	.028	.028	.028	.028	.028	.028	.028	.028	.028	.028
3/16	.030	.030	.030	.030	.030	.030	.030	.030	.030	.030	.030	.030	.030	.030	.035
1/4	.030	.030	.030	.030	.030	.030	.030	.030	.030	.035	.030	.030	.030	.042	.049
5/16	.032	.032	.032	.032	.032	.032	.032	.032	.035	.049	.032	.032	.035	.049	.058
3/8	.032	.032	.032	.032	.042	.032	.032	.032	.042	.058	.032	.032	.042	.058	—
1/2	.032	.032	.032	.042	.049	.032	.032	.042	.058	.072	.032	.042	.058	.083	—
5/8	.035	.035	.042	.049	.065	.035	.035	.058	.072	.095	.035	.049	.072	.095	—
3/4	.035	.035	.049	.058	.072	.035	.049	.065	.095	.109	.035	.058	.095	—	—
7/8	.049	.049	.058	.072	.083	.049	.058	.083	.109	—	.049	.065	.109	—	—
1	.049	.049	.058	.083	.095	.049	.058	.095	—	—	.049	.072	—	—	—
1-1/4	.049	.049	.072	.095	.120	.049	.072	.109	—	—	.049	.095	—	—	—
1-1/2	.065	.065	.095	—	—	.065	.095	—	—	—	.065	—	—	—	—
2	.065	.083	.120	—	—	.065	—	—	—	—	.083	—	—	—	—

 Both SAE 37° SINGLE FLARE FLARE-TWIN or ERMETO® flareless recommended.

 ERMETO® flareless only.

NOTE: Only Weatherhead Ermeto flareless fittings can be used with high pressure, heavy wall tubing which is impractical to flare.

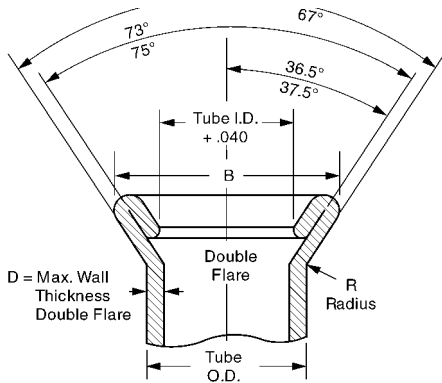
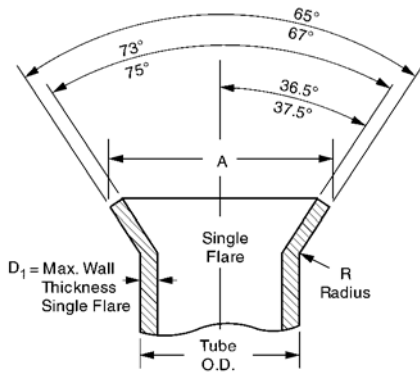

**JIC 37° FLARE TUBES
(SAE J533)**

Tube Size O.D.	Single Flare A Diameter		Double Flare B Diameter		R Radius ±.020	Maximum Wall Thickness	
	Max.	Min.	Max.	Min.		Single Flare D	Double Flare D ₁
1/8	.200	.180	.200	.180	.030	.035	.025
3/16	.280	.260	.280	.260	.030	.035	.028
1/4	.360	.340	.360	.340	.030	.065	.035
5/16	.430	.400	.430	.400	.030	.065	.035
3/8	.490	.460	.490	.460	.040	.065	.049
1/2	.660	.630	.660	.630	.060	.083	.049
5/8	.790	.760	.790	.760	.060	.083	.049
3/4	.950	.920	.960	.920	.080	.109	.049
7/8	1.070	1.040	1.070	1.040	.080	.109	.065
1	1.200	1.170	1.200	1.170	.090	.120	.065
1 1/4	1.510	1.480	1.510	1.480	.090	.120	.065
1 1/2	1.730	1.700	1.730	1.700	.110	.120	.065
2	2.360	2.330	2.360	2.330	.110	.134	.065

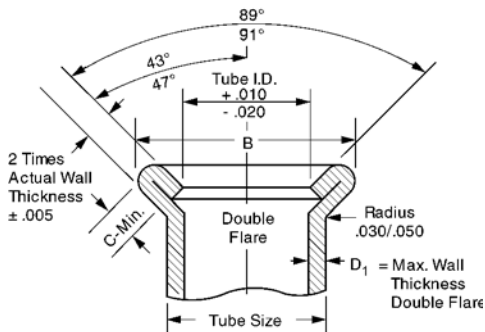
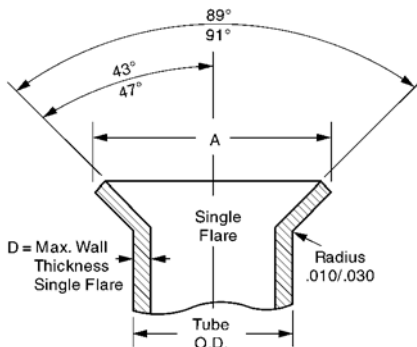

**SAE 45° FLARE TUBE
(SAE J533)**

Tube Size	Single Flare A Diameter		Double Flare B Diameter		Double Flare Coined Seat Length C	Maximum Wall Thickness	
	Max.	Min.	Max.	Min.		Single Flare D	Double Flare D ₁
1/8	.171	.181	.198/	.213	.040	.035	.025
3/16	.239/	.249	.265/	.280	.040	.035	.028
1/4	.315/	.325	.345/	.360	.040	.049	.035
5/16	.388/	.404	.410/	.425	.062	.049	.035
3/8	.471/	.487	.485/	.500	.062	.065	.049
7/16	.545/	.561	.555/	.570	.062	.065	.049
1/2	.607/	.623	.625/	.640	.062	.083	.049
9/16	.660/	.676	.697/	.712	.062	.083	.049
5/8	.732/	.748	.757/	.772	.062	.095	.049
3/4	.900/	.916	.897/	.912	.062	.109	.049
7/8	1.025/	1.041	—	—	—	.109	—
1	1.141/	1.157	—	—	—	.120	—

 Refer to safety information regarding tubing installation on page 2.

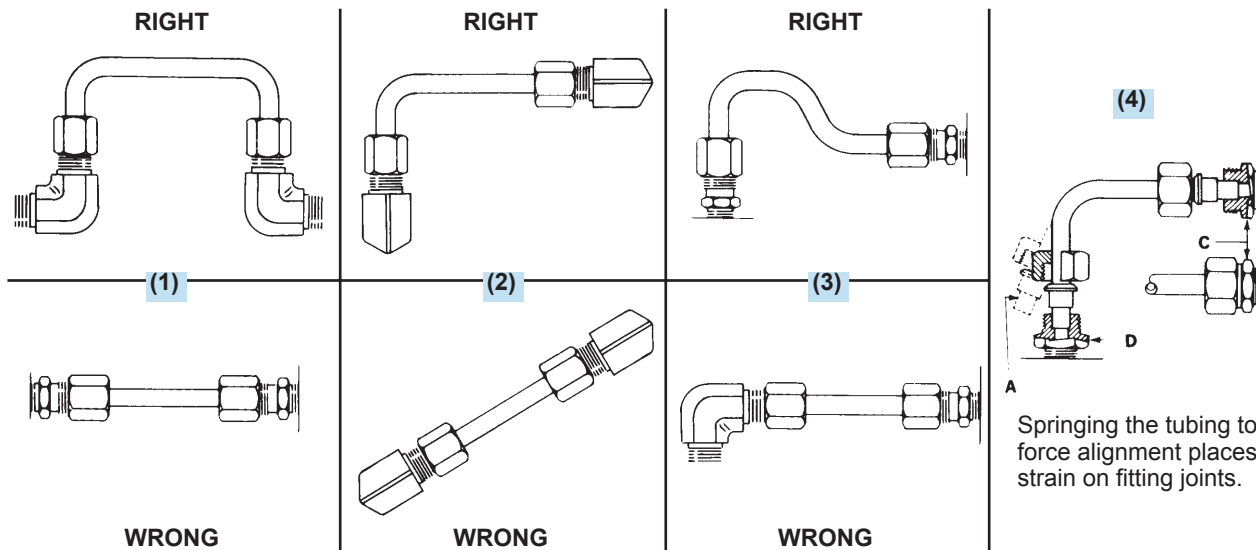

(4) Springing the tubing to force alignment places strain on fitting joints.

Nearly all industrial equipment now in service makes some use of fluid lines. From an economic point of view, the best fluid lines system is that which is easiest to maintain at the lowest original cost. The use of tubing and tube fittings on lines up to 2" diameter is usually more economical than the use of pipe and pipe fittings in modern installations. A few of the more important reasons follow:

1. Size for size, tubing is lighter weight, easier to handle and can be bent more easily than iron pipe.
2. Ductile hydraulic tubing reduces the number of connections required, thus reducing material and labor costs. Bent tubing also reduces pressure drop and turbulence in the system.
3. Fewer joints means lower costs and fewer points of potential leakage.
4. The use of tube fittings makes every joint a union, permitting easier, faster maintenance and repair work.
5. Modern flared and flareless tube fittings eliminate the need for threading, soldering, or welding.

TUBE BENDING

Tubing should be bent wherever possible to reduce the number of fittings.

Copper tubing can be bent easily with a hand bender. Steel tubing can be bent in sizes 1/8" to 5/8" O.D. by using a hand bender designed for steel tubing. For production quantities, or for sizes larger than 5/8" O.D., a power bender is generally used.

Tubing should be bent accurately. Tubing manufacturers will advise the correct radii for various types and wall thicknesses of tubing. Kinks, flattened bends, wrinkles and tube breakage or loss should be avoided by the use of proper tube bending equipment.

PRECAUTIONS

Avoid straight line connections wherever possible, especially in short runs.

Design piping systems symmetrically. They are easier to install and present a neat appearance.

Care should be taken to eliminate stress from tubing lines. Long tubing runs should be supported by brackets or clips. All parts installed on tubing lines such as heavy fittings, valves, etc., should be bolted down to eliminate tubing fatigue.

Before installing tubing, inspect the tube to see that it conforms to the required specifications, is of the correct diameter and wall thickness and is not out of round.

Cut tube ends reasonably square and lightly deburr inside and outside edge. Chamfer on outside edge will destroy bearing of tube end on the fittings seat.

To avoid difficulty in assembly and disconnecting, a sufficient straight length of tube must be allowed from the end of the tube to the start of the bend. Allow twice the length of the nut as a minimum.

Tubes should be formed to assemble with true alignment to the center line of the fittings, without distortion or tension. Tubing which has to be sprung from position, "A", (see Fig. 4), to be inserted into the fitting has not been properly fabricated, and when so installed and connected, places the tubing under stress.

When assembling the tubing, insert the longer leg to the fitting as at "C" (Fig. 4). With the nut free, the short leg of the tubing can be easily moved and brought to proper position with and inserted into the seat in fitting "D". The nuts can then be tightened as required.



Refer to safety information regarding proper selection of tubing and tube fittings on page 1.

These tables alphabetically list commonly used materials of various chemical composition. After each agent listing you will find the basic tubing and fitting materials rated according to their chemical resistance to each individual agent. The chart is intended to be used as a guide only. Many factors (concentration, temperature, intermittent or continuous exposure, etc.) have a bearing upon the suitability of any tubing or connector for any specific application, and these factors must be considered by you as you review the chemical compatibility chart.

Where unusual conditions exist or where questions arise, consult Boston Weatherhead for expert assistance on your tubing application requirements.

Fluid	Nylon 11 TP160, NT100	Nylon 6/6 PT230	PVC PT200	Polyethylene PT240 (LDPE)	Brass	Steel	316 Stainless
Acetaldehyde	G	F	X	X	X	X	G
Acetic Acid (Concentrated)	X	X	X	X	X	X	G
Acetic Acid (Dilute)	F	X	F	G	X	X	G
Acetic Anhydride	X	X	X	X	X	F	F
Acetone	G	F	X	G	G	G	G
Acrylonitrile	G	—	G	—	—	G	G
Air	G	G	G	G	G	G	G
Alcohols							
Amyl Alcohol	G	G	X	G	G	F	F
Butyl Alcohol, Butanol	G	G	X	G	G	G	G
Ethyl Alcohol, Ethanol	G	G	F	G	G	F	G
Isopropyl Alcohol, Isopropanol	G	G	G	G	G	G	G
Methyl Alcohol, Methanol	G	G	X	G	G	F	G
Aluminum Chloride	X	X	G	G	X	X	F
Aluminum Fluoride	X	X	G	G	X	X	X
Aluminum Hydroxide	G	G	G	G	X	F	G
Aluminum Nitrate	G	F	G	G	X	X	G
Aluminum Sulfate	G	F	G	G	X	X	G
Alums	F	G	G	G	X	X	F
Ammonia, Anhydrous	Use approved anhydrous ammonia hose				X	F	G
Ammonia Solution (10%)	G	X	G	G	X	G	G
Ammonium Chloride	X	X	G	G	X	G	F
Ammonium Hydroxide	G	X	X	G	X	F	G
Ammonium Nitrate	G	G	G	G	—	—	G
Ammonium Phosphate	G	G	F	G	X	X	G
Ammonium Sulfate	G	G	G	G	X	X	F
Amyl Acetate	G	G	X	X	G	F	G
Amyl Alcohol	G	G	X	G	G	F	F
Aniline	X	X	X	X	X	G	G
Aniline Dyes	X	X	X	X	X	X	F
Animal Oils and Fats	G	—	G	X	G	G	G
Anti-Freeze (Glycol Base)	G	—	G	F	G	G	G
Aqua Regia	X	X	X	X	—	X	X
Aromatic Hydrocarbons	G	G	X	G	G	G	G
Asphalt Emulsion	G	—	X	—	G	G	G
Barium Chloride	G	—	G	G	X	F	G
Barium Hydroxide	G	G	G	G	X	G	G
Barium Sulfate	G	G	G	G	G	G	G
Barium Sulfide	X	—	G	G	X	X	G
Beet Sugar Liquors	G	G	G	G	X	G	G
Benzaldehyde	G	G	X	X	F	F	G
Benzene, Benzol	G	G	X	X	G	G	G
Benzoic Acid	X	X	X	G	F	X	F
Black Sulfate Liquor	X	X	X	G	X	G	G
Bleach Solution	X	X	F	G	X	X	G
Borax Solution	G	—	G	G	G	G	G
Boric Acid	G	G	G	G	X	X	G
Brake Fluid (Glycol Ether Base)	G	—	X	X	G	G	G
Brine	G	—	G	G	—	X	F
Bromine	X	X	X	X	X	X	X

NOTE: All data given herein is believed to be accurate and reliable but presented without guarantee, warranty, or responsibility of any kind, express or implied, on our part. Chemical resistance will vary with the wide diversity of possible mixtures and service conditions. It is not therefore possible to give any guarantee whatsoever in individual cases. CODES: G=Good Resistance F=Fair Resistance X=Incompatible — =No data available

+ Call Technical Support for specific application

Chemical Compatibility Chart

Application



Refer to safety information regarding proper selection of tubing and tube fittings on page 1.

Fluid	Nylon 11 TP160, NT100	Nylon 6/6 PT230	PVC PT200	Polyethylene PT240 (LDPE)	Brass	Steel	316 Stainless
Butane	Use H336 or H243 Hose Only						
Butyl Acetate	G	—	X	X	G	G	G
Butyl Alcohol, Butanol	G	G	X	G	G	G	G
Calcium Bisulfite	G	X	G	G	X	X	X
Calcium Chloride	G	X	G	G	X	F	F
Calcium Hydroxide	G	G	G	G	F	G	G
Calcium Hypochlorite	X	X	G	G	F	X	F
Cane Sugar Liquors	G	—	G	G	F	G	G
Carbon Dioxide (Dry)	G	G	G	G	G	G	G
Carbon Dioxide (Wet)	G	G	G	G	F	G	G
Carbon Disulfide (Bisulfide)	X	X	X	X	G	G	G
Carbon Monoxide (Hot)	X	X	X	X	X	F	G
Carbon Tetrachloride	G	G	X	X	G	G	G
Carbonic Acid	G	—	G	G	X	X	F
Castor Oil	G	—	G	X	G	G	G
Cellosolve Acetate	G	—	X	—	X	X	G
Chlorinated Solvents	F	G	X	X	G	G	F
Chloroacetic Acid	X	X	X	X	X	X	F
Chlorobenzene	X	X	X	X	F	F	G
Chlorine Gas (Dry)	X	X	X	X	F	F	G
Chlorine Gas (Wet)	X	X	X	X	X	X	X
Chloroform	F	G	X	X	G	G	G
Chlorosulfonic Acid	X	X	X	X	X	F	X
Chromic Acid (under 25%)	X	X	F	F	X	X	G
Chromic Acid (over 25%)	X	X	X	X	X	X	F
Citric Acid	X	F	G	G	X	X	G
Coke Oven Gas	G	—	X	G	F	G	G
Copper Chloride	X	X	G	G	X	X	G
Copper Cyanide	G	G	G	G	X	X	G
Copper Sulfate	G	G	G	G	X	X	G
Corn Syrup (Non-food)	G	—	G	G	—	G	G
Cottonseed Oil	G	—	F	G	G	G	G
Creosote	X	X	X	X	F	—	G
Cresol	X	X	X	X	—	G	G
Cyclohexanol	G	G	X	F	G	F	G
Dextrose (Food Grade)	X	X	X	G	—	—	G
Dichlorobenzene	G	—	X	X	—	—	G
Diesel Fuel	G	—	X	X	G	G	G
Diethanolamine	G	—	X	—	X	G	G
Diethylenetriamine	X	X	X	G	—	—	—
Dowtherm A	X	X	X	X	X	F	G
Enamel (Solvent Base)	G	—	X	G	G	—	G
Ethanolamine	G	—	X	G	X	G	G
Ethers (Ethyl Ether)	G	—	X	X	G	G	G
Ethyl Alcohol	G	G	F	G	F	G	G
Ethyl Acetate	G	G	X	G	G	G	G
Ethyl Acrylate	X	—	X	—	—	G	G
Ethyl Methacrylate	X	—	X	—	—	G	G
Ethylamine	X	X	X	G	G	—	G
Ethyl Cellulose	F	—	X	G	F	G	F
Ethyl Chloride	G	—	X	X	F	F	G
Ethylenediamine	X	X	X	G	G	G	G
Ethylene Dibromide	F	—	X	—	—	—	—
Ethylene Dichloride	F	—	X	X	G	X	X
Ethylene Glycol	G	G	G	G	F	G	G
Ethylene Oxide	G	—	X	X	X	F	F

NOTE: All data given herein is believed to be accurate and reliable but presented without guarantee, warranty, or responsibility of any kind, express or implied, on our part. Chemical resistance will vary with the wide diversity of possible mixtures and service conditions. It is not therefore possible to give any guarantee whatsoever in individual cases. CODES: G=Good Resistance F=Fair Resistance X=Incompatible —=No data available

+ Call Technical Support for specific application

APPLICATION



Refer to safety information regarding proper selection of tubing and tube fittings on page 1.

Fluid	Nylon 11 TP160, NT100	Nylon 6/6 PT230	PVC PT200	Polyethylene PT240 (LDPE)	Brass	Steel	316 Stainless
Fatty Acids	G	G	G	G	F	F	G
Ferric Chloride 5%	G	G	G	G	X	X	X
Ferric Sulfate	G	G	G	G	X	X	F
Fertilizer Salts Solution	F	—	G	G	—	—	G
Formaldehyde	G	G	X	G	F	X	G
Formic Acid	X	X	X	G	F	X	G
Freon 12	Use approved Freon 12 hose				G	G	G
Freon 134a	Use approved Freon 134a hose				—	G	G
Fuel Oil	G	—	F	X	F	G	G
Furfural	X	X	X	X	F	G	G
Gasoline (Refined)	G	G	X	X	G	G	G
Gasoline (Unleaded)	G	G	X	X	G	G	G
Gasoline (10% Ethanol)	G	G	X	X	G	G	G
Gasoline (10% Methanol)	G	G	X	X	G	G	G
Glucose (non-food)	G	G	G	G	G	G	G
Glycerine, Glycerol (Non-food)	G	G	G	G	G	G	G
Greases	G	G	G	G	G	G	G
Green Sulfate Liquor	X	X	G	G	X	X	G
Heptane	G	G	X	X	G	G	G
Hexane	G	G	X	X	G	G	G
Houghto Safe 273 to 640	G	—	F	G	G	G	G
Houghto Safe 5046, 5047F	G	—	G	G	G	G	G
Houghto Safe 1000 Series	G	—	X	X	G	G	G
Hydraulic Oils							
Straight Petroleum Base	G	G	G	G	G	G	G
Water Petroleum Emulsion	G	—	—	F	G	G	G
Water Glycol	G	G	X	—	G	G	G
Straight Phosphate Ester	G	G	X	X	G	G	G
Phos. Ester/Petroleum Blend	G	G	X	X	G	G	G
Polyol Ester	G	—	—	—	G	G	G
Hydrobromic Acid (under 48%)	X	X	G	G	X	X	X
Hydrochloric Acid	X	X	G	G	X	X	X
Hydrocyanic Acid	X	X	G	G	X	F	G
Hydrofluoric Acid (under 50%)	X	X	F	F	X	X	G
Hydrofluoric Acid (over 50%)	X	X	X	X	X	X	G
Hydrofluosilicic Acid	X	X	G	G	X	X	X
Hydrogen	Use approved hydrogen hose or metal tubing				—	—	G
Hydrogen Peroxide	X	X	—	G	X	X	G
Hydrogen Sulfide	X	X	G	G	F	F	F
Hydrolube	G	—	G	G	G	G	G
Iodine	X	X	X	X	X	X	X
Isocyanates	X	X	X	X	—	—	—
Isopropyl Alcohol, Isopropanol	G	G	G	G	G	G	G
Isopropylamine	X	—	X	—	G	—	G
Iso-Octane	G	G	X	X	G	G	G
Jet Fuel (Transfer Only)	G	G	X	X	G	F	G
Kerosene	G	G	X	X	G	G	G
Lacquer	G	G	X	F	G	X	G
Lacquer Solvents	G	G	X	F	G	X	G
Lactic Acid	G	G	G	G	F	F	G
Lime Sulfur	G	F	G	G	X	—	G
Lindol	G	G	—	—	F	G	G
Linseed Oil	G	G	G	G	F	G	G
Lubricating Oils	G	G	G	G	G	G	G
Lye	G	F	G	G	F	X	G
Magnesium Chloride	G	G	G	G	F	F	G

NOTE: All data given herein is believed to be accurate and reliable but presented without guarantee, warranty, or responsibility of any kind, express or implied, on our part. Chemical resistance will vary with the wide diversity of possible mixtures and service conditions. It is not therefore possible to give any guarantee whatsoever in individual cases. CODES: G=Good Resistance F=Fair Resistance X=Incompatible —=No data available

+ Call Technical Support for specific application

Chemical Compatibility Chart

Application

 Refer to safety information regarding proper selection of tubing and tube fittings on page 1.

Fluid	Nylon 11 TP160, NT100	Nylon 6/6 PT230	PVC PT200	Polyethylene PT240 (LDPE)	Brass	Steel	316 Stainless
Magnesium Hydroxide	G	G	G	G	G	G	G
Magnesium Sulfate	G	G	G	G	F	G	G
Mercuric Chloride	X	X	F	G	X	X	X
Mercury	G	G	F	G	X	G	G
Methyl Alcohol, Methanol	G	G	X	G	F	G	G
Methyl Acrylate	X	X	X	—	G	G	G
Methyl Bromide	G	F	X	X	G	G	G
Methyl Chloride	G	G	X	X	G	G	G
Methylene Chloride	F	F	X	X	G	G	G
Methyl t-Butyl Ether (MTBE)	G	G	X	—	—	G	G
Methyl Ethyl Ketone	G	G	X	G	G	G	G
Methyl Isobutyl Ketone	G	G	X	G	G	G	G
Methyl Isopropyl Ketone	G	G	X	G	G	G	G
Methyl Methacrylate	X	—	X	—	—	G	G
Mineral Oil	G	G	F	X	G	G	G
Mineral Spirits	G	G	X	G	G	G	G
Naphtha	G	G	X	G	F	G	G
Naphthalene	G	G	X	X	F	G	G
Nickel Acetate	G	G	G	G	G	G	G
Nickel Chloride	G	G	G	G	X	X	F
Nickel Sulfate	G	G	G	G	X	X	G
Nitric Acid (under 35%)	X	X	G	F	X	X	G
Nitric Acid (35% to 60%)	X	X	F	X	X	X	G
Nitric Acid (over 60%)	X	X	X	X	X	X	G
Nitrobenzene	X	—	X	X	F	G	G
Nitrogen Gas	G	G	G	G	G	G	G
Nitrous Oxide	F	F	X	X	G	G	G
Oleic Acid	G	G	F	G	F	F	G
Oleum (Fuming Sulfuric Acid)	X	X	X	X	X	F	G
Oxalic Acid	X	X	G	G	F	X	G
Oxygen	G	G	G	G	G	G	G
(non-breathing, non-welding) +							
Ozone (300 ppm)	X	X	X	X	—	F	G
Paint (Solvent Base)	G	G	X	F	G	G	G
Palmitic Acid	G	G	F	G	X	F	F
Paper Mill Liquors	X	X	X	X	—	—	—
Pentane	G	—	X	X	G	G	G
Perchloroethylene	F	G	X	X	F	G	G
Petroleum Ether	G	G	X	X	G	G	G
Petroleum Oils	G	G	G	G	G	G	G
Phenol	X	X	X	X	F	X	F
Phosphoric Acid (to 85%)	X	X	G	G	X	X	F
Picric Acid (Molten)	X	X	X	X	X	X	F
Picric Acid (Solution)	X	X	X	X	X	X	F
Potassium Chloride	G	G	G	G	F	X	G
Potassium Cyanide	G	G	G	G	X	G	G
Potassium Dichromate	F	—	G	G	X	G	G
Potassium Hydroxide	G	F	G	G	F	X	G
Potassium Permanganate	X	X	G	G	—	—	—
Potassium Sulfate	G	G	G	G	F	F	G
Propane Liquid	Use H366 Hose Only						
Propylene Glycol	G	—	F	G	F	G	G
Pyridine	X	X	X	G	F	G	G
Sea Water	G	G	G	G	G	F	G
Silver Nitrate	G	G	G	G	X	X	F
Skydrol	G	G	X	X	G	G	G

NOTE: All data given herein is believed to be accurate and reliable but presented without guarantee, warranty, or responsibility of any kind, express or implied, on our part. Chemical resistance will vary with the wide diversity of possible mixtures and service conditions. It is not therefore possible to give any guarantee whatsoever in individual cases. CODES: G=Good Resistance F=Fair Resistance X=Incompatible —=No data available

+ Call Technical Support for specific application

APPLICATION

 Refer to safety information regarding proper selection of tubing and tube fittings on page 1.

Fluid	Nylon 11 TP160, NT100	Nylon 6/6 PT230	PVC PT200	Polyethylene PT240 (LDPE)	Brass	Steel	316 Stainless
Soap Solution	G	G	G	X	G	G	G
Sodium Bicarbonate	G	G	G	G	F	F	G
Sodium Bisulfate	G	G	G	G	F	F	F
Sodium Bisulfite	G	G	G	G	F	X	G
Sodium Borate	G	G	G	G	G	G	G
Sodium Carbonate	G	G	G	G	X	G	G
Sodium Chloride	G	G	G	G	X	F	G
Sodium Cyanide	G	G	G	G	X	F	G
Sodium Hydroxide	G	F	G	G	F	X	G
Sodium Hypochlorite	X	X	G	G	X	X	F
Sodium Nitrate	G	G	G	G	F	G	G
Sodium Perborate	G	F	G	G	F	F	G
Sodium Peroxide	X	X	X	X	X	F	G
Sodium Phosphates	G	G	G	G	F	F	F
Sodium Silicate	G	G	G	G	F	F	G
Sodium Sulfate	G	G	G	G	F	F	G
Sodium Sulfide	G	G	G	G	X	X	G
Sodium Thiosulfate	G	G	G	G	X	X	G
Soybean Oil	G	—	F	G	G	G	G
Stannic Chloride	F	X	G	G	X	X	X
Steam 450° F	X	X	X	X	F	F	G
Stearic Acid	G	G	F	G	X	X	G
Stoddard Solvent	G	G	X	X	G	G	G
Styrene	G	G	X	X	G	G	G
Sulfur 70o F	G	G	F	G	X	X	G
Sulfur 200o F	X	X	X	X	X	X	G
Sulfur Chloride	X	X	X	G	X	X	X
Sulfur Dioxide	X	X	X	X	X	—	G
Sulfuric Acid (under 50%)	X	X	G	G	X	X	X
Sulfuric Acid (51% to 70%)	X	X	G	X	X	X	X
Sulfuric Acid (71% to 95%)	X	X	X	X	X	X	X
Sulfuric Acid (96% to 98%)	X	X	X	X	X	X	X
Tannic Acid	X	X	G	G	F	X	G
Tar	G	G	X	X	F	F	G
Tartaric Acid	G	G	G	G	F	X	F
Tetrachloroethane	F	—	X	F	—	—	G
Tetrahydrofuran (THF)	G	—	X	X	—	—	G
Toluene	G	G	X	G	G	G	G
Transmission Oil (Petrol. Base)	G	G	G	G	G	G	G
Trichloroethane	F	G	X	G	G	G	G
Trichloroethylene	F	G	X	G	G	G	G
Tung Oil	G	—	—	—	F	G	G
Turpentine	G	G	X	G	F	G	G
Urea (Water Solution)	G	G	G	G	—	G	G
Uric Acid	G	G	G	G	—	—	F
Varnish	G	G	X	G	G	G	G
Vegetable Oil (Non-food)	G	G	F	G	G	G	G
Vinegar	G	X	G	G	X	F	G
Vinyl Acetate	G	—	X	—	F	G	G
Water (non-potable)	G	G	G	G	F	F	G
Water-Glycol Mixture	G	G	X	—	G	G	G
Water-Petroleum Mixture	G	G	—	F	G	G	G
Xylene	G	G	X	G	G	G	G
Zinc Chloride	X	X	G	G	X	X	X
Zinc Sulfate	G	G	G	G	X	X	G

NOTE: All data given herein is believed to be accurate and reliable but presented without guarantee, warranty, or responsibility of any kind, express or implied, on our part. Chemical resistance will vary with the wide diversity of possible mixtures and service conditions. It is not therefore possible to give any guarantee whatsoever in individual cases. CODES: G=Good Resistance F=Fair Resistance X=Incompatible —=No data available

+ Call Technical Support for specific application

Plastic Tubing

Tubing

Example of complete part numbers: NT10006RD-100 (Catalog Number, Color, Coil Length)

NT100 "Nylon 11"

SAE J844 Type A & B DOT FMVSS 571.106

Typical Application: Air brake systems except where temperatures exceed +200°F or where battery acid can drip on tubing.

Construction: Core, Nylon; Braid, Polyamide Fiber (3/8" and larger sizes only); Jacket, Nylon.

Temperature Range: -40°F to +200°F (-40°C to +93°C)

Available Colors: Black (BK), red (RD), blue (BU), brown (BR), gray (GY), green (GN), yellow (YW), orange (OR) and white (WH). Refer to current price list for availability of colors. Example of complete part numbers: NT10006RD-100.

Contains: Ultra-Violet Stabilizer in all colors.



NOTE: 1/8", 5/32", 3/16", 1/4" and 5/16", are SAE J844 Type A (not reinforced); 3/8", 1/2", 5/8" and 3/4" are SAE J844 Type B (reinforced).

* Insert not required. Does not meet DOT standards.

NOTE: Not all colors available in all sizes. Refer to price pages for availability.

Catalog Number	Tube O.D. (in)	Tube Wall (in)	Max. Work. Pres. PSI 75°	Min. Burst Pres. PSI 75°	Min. Bend Radius 70° F	Lbs. Per 100 Ft.	Coil Length(s) (Ft)	Fittings
NT10002*	1/8 (.125)	.023	150	1,000	.375"	.4	100,500,1000	BW 1800 SERIES Q>CAB® FITTINGS (Pg. 83-90). BW 1400 SERIES AIR BRAKE Fittings. (Pg. 91-96) For 1/8" NT10002 Tubing use SELFALIGN® Fittings (Pg. 54-59). NOTE: SELFALIGN® Fittings are not designed to meet DOT standards.
NT10025*	5/32 (.156)	.032	150	1,200	.5"	.4	100,1000	
NT10003	3/16 (.187)	.035	150	1,200	.75"	.6	1000	
NT10004	1/4 (.250)	.040	150	1,200	1.0"	1.2	100,500,1000	
NT10005	5/16 (.312)	.040	150	1,000	1.25"	1.8	100,500,1000	
NT10006	3/8 (.375)	.062	150	1,400	1.5"	2.9	100,500,1000	
NT10008	1/2 (.500)	.062	150	950	2.0"	3.8	100,500,1000	
NT10010	5/8 (.625)	.092	150	900	2.5"	6.8	100,250	
NT10012	3/4 (.750)	.092	150	800	3.0"	8.4	100,250	

PT200 Polyvinyl Chloride

Typical Application: Soft, pliable, plasticized PVC Resin Tubing, for practically any low pressure laboratory, industrial, agricultural or domestic application.

Temperature Range: -5°F to +105°F (-20°C to +41°C)

Available Colors: Clear (suffix NA)

WEATHERHEAD

Catalog Number	Tube O.D. (in)	Tube Wall (in)	Max. Work. Pres. PSI 75°	Min. Burst Pres. PSI 75°	Min. Bend Radius 70° F	Lbs. Per 100 Ft.	Coil Length(s) (Ft)	Fittings
PT20004	1/4 (.250)	.062	65	195	1.0"	2.0	100	BW POLYLINE® (Pg.60-64). SELFALIGN® (Pg. 54-59) with 2030x insert, and COMPRESSION (Pg. 48-53), with 2030x insert. See page 49 for insert. MOLDED COMPRESSION (Pg. 126-136).
PT20044	1/4 (.250)	.040	55	165	1.0"	2.0	100	
PT20005	5/16 (.312)	.062	55	165	1.25"	2.6	100	
PT20006	3/8 (.375)	.062	55	165	1.5"	3.3	100	
PT20008	1/2 (.500)	.062	45	135	2.0"	4.6	100	
PT20010	5/8 (.625)	.062	30	90	2.5"	5.9	100	
PT20012	3/4 (.750)	.094	40	120	3.0"	10.3	100	
PT20016	1(1.00)	.125	35	105	4.0"	18.5	100	

NOTE: SELFALIGN® Fittings are not designed to meet DOT standards. For plastic tube cutter, see page 226.

WEATHERHEAD®

Example of complete part numbers: NT10006RD-100 (Catalog Number, Color, Coil Length)

PT230 Polyamide “Nylon 6/6”

Natural off-white compound covered under 21CFR177.1500 regulations for food contact.

Typical Application: Semi-rigid general purpose tubing.

Temperature Range: -40°F to +180°F (-40°C to +82°C)

Available Colors: Natural off-white (NA) and black (BK). FDA colors available on request.

Contains: Ultra-Violet Stabilizer in black tubing.

WEATHERHEAD



Catalog Number	Tube O.D. (in)	Tube Wall (in)	Max. Work. Pres. PSI 70°	Min. Burst Pres. PSI 70°	Min. Bend Radius 70° F	Lbs. Per 100 Ft.	Coil Length(s) (Ft)	Fittings
PT23002	1/8 (.125)	.015	300	1,000	.75"	.3	100,1,000	BW SELFALIGN® (Pg. 54-59). PUSH > CONNECT (Pg. 65-78), PUSH > CONNECT Flow Controls (Pg. 65, 75-76), PUSH > CONNECT PLUS (Pg. 77-78), and POLYLINE® w/brass sleeves (Pg. 60-64).
PT23003	3/16 (.188)	.023	300	1,000	1.25"	.6	100,1,000	
PT23004	1/4 (.250)	.030	300	1,000	1.5"	1.0	100,1,000	
PT23005	5/16 (.312)	.036	300	1,000	2.0"	1.5-1.6	100,1,000	
PT23006	3/8 (.375)	.040	300	1,000	2.25"	2.1	100,1,000	
PT23008	1/2 (.500)	.062	300	1,000	3.0"	4.2-4.3	100, 500	

PT240 Polyethylene

Natural off-white compound covered under 21CFR177.1520 regulations for food contact.

Typical Application: Economical, flexible, low density Polyethylene has a wide range of uses in industrial and agricultural applications.

Temperature Range: -40°F to +135°F (-40°C to +57°C)

Available Colors: Natural off-white (NA), black (BK), yellow (YW), orange (OR), blue (BU), red (RD), green (GN). FDA colors available on request. Refer to current price list for availability of colors.

Contains: Ultra-Violet Stabilizer in black tubing.

WEATHERHEAD



Catalog Number	Tube O.D. (in)	Tube Wall (in)	Max. Work. Pres. PSI 70°	Min. Burst Pres. PSI 70°	Min. Bend Radius 70° F	Lbs. Per 100 Ft.	Coil Length(s) (Ft)	Fittings
PT24004	1/4 (.250)	.062	200	600	.75"	1.5	100,1,000	BW MINIBARB® (Pg. 79-82), POLYLINE® (Pg. 60-64), SELFALIGN® (Pg. 54-59) with 2030 insert (Pg. 56), and PUSH > CONNECT Flow Controls (Pg. 65, 75-76), PUSH > CONNECT (Pg. 65-70), PUSH > CONNECT PLUS (Pg. 77-78). MOLDED COMPRESSION (Pg. 129-136).
PT24044	1/4 (.250)	.040	133	400	.62"	1.0	100,1,000	
PT24005	5/16 (.312)	.062	135	480	1.0"	1.9	100,1000	
PT24006	3/8 (.375)	.062	135	400	1.5"	2.4	100,1,000	
PT24008	1/2 (.500)	.062	100	300	2.0"	3.4	100, 500	
PT24010	5/8 (.625)	.062	80	240	2.5"	4.4	100	
PT24012	3/4 (.750)	.094	70	210	3.0"	7.6	100	
PT24016	1 (1.000)	.125	100	300	5.0"	13.4	100	

Plastic Tubing

Tubing

Example of complete part numbers: NT10006RD-100 (Catalog Number, Color, Coil Length)

TP160 Polyamide "Nylon 11"

Typical Application: Flexible nylon tubing. Used for instrumentation; lubrication and air lines; gas, chemical and oil processing; low pressure hydraulics.

Temperature Range: -40°F to +200°F (-40°C to +93°C)

Available Colors: Black (BK) or natural (NA).

Contains: Ultra-Violet Stabilizer in black tubing.

WEATHERHEAD



Catalog Number	Tube O.D. (in)	Tube Wall (in)	Max. Work. Pres. PSI 70°	Min. Burst Pres. PSI 70°	Min. Bend Radius 70° F	Lbs. Per 100 Ft.	Coil Length(s) (Ft)	Fittings
TP16002	1/8 (.125)	.023	250	1,000	.62"	.30	100,1,000	BW POLYLINE® with Brass Sleeves (Pg. 60-64). SELFALIGN® (Pg. 54-59). PUSH > CONNECT Flow Controls (Pg. 65, 75-76), PUSH > CONNECT (Pg. 65-70). COMPRESSION (Pg. 48-53). PUSH > CONNECT PLUS (Pg. 77-78). MOLDED COMPRESSION (Pg. 129-136).
TP16025	5/32 (.156)	.029	250	1,000	1"	.75	100,1,000	
TP16004	1/4 (.250)	.040	250	1,000	1.25"	1.2	100,1,000	
TP16005	5/16 (.312)	.040	250	1,000	2"	2.0	100,1,000	
TP16006	3/8 (.375)	.062	250	1,000	3"	2.7	100,1,000	
TP16008	1/2 (.500)	.062	250	1,000	4.5"	3.8	100,500	

TUBING

MTP160 Polyamide "Nylon 11" Metric Tubing

Typical Application: Flexible nylon tubing. Used for instrumentation; lubrication and air lines; gas, chemical and oil processing; low pressure hydraulics.

Temperature Range: -40°F to +200°F (-40°C to +93°C)

Available Colors: Natural (NA).

Contains: Ultra-Violet Stabilizer

WEATHERHEAD



Catalog Number	Tube O.D. (in)	Tube Wall (in)	Max. Work. Pres. PSI 75°	Min. Burst Pres. PSI 75°	Min. Bend Radius 75° F	Lbs. Per 100 Ft.	Coil Length(s) (Ft)	Fittings
MTP16004	4	.65	250	1,000	.75"	0.6	100	BW METRIC PUSH > CONNECT (Pg. 65, 71-74).
MTP16005	5	1	250	1,000	1"	0.9	100	
MTP16006	6	1	250	1,000	1.5"	1.1	100	
MTP16008	8	1	250	1,000	2.25"	1.5	100	
MTP16010	10	1	200	800	3"	1.9	100	
MTP16012	12	1	112	450	3.5"	2.3	100	

For plastic tube cutter, see page 226.

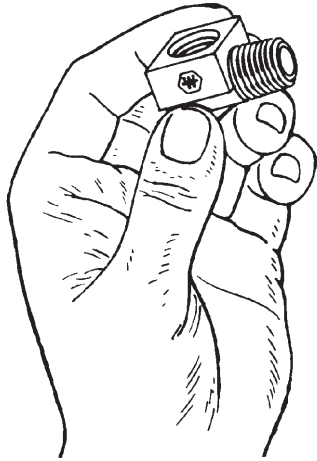

Weatherhead brass tube fittings are made from high quality UNS CA-360 brass bar. Weatherhead brass fittings are precision machined to meet SAE standards and specifications. Large, uniform wrench pad areas have standard dimensions for easy assembly and disassembly using standard open-end wrenches. On fittings where pipe threads are used, the fittings are standardized on Dryseal American National Standard Taper. Weatherhead offers the only complete line of brass fittings with these outstanding advantages.

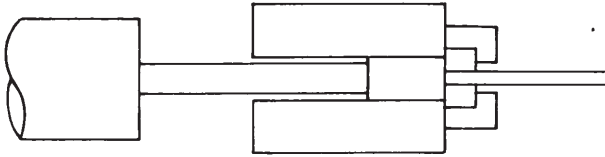

Hot Extrusion

A cast billet is heated and extruded through a die containing the desired configuration. This process recrystallizes the weaker cast structure into the stronger pressed structure of the shaped extrusion.



Cold Draw

The hot extruded shape is pulled through a die with the same configuration but less cross sectional area. This further recrystallizes and refines the structure while increasing the strength and elongation. In addition, the dimensions are brought to close tolerances.

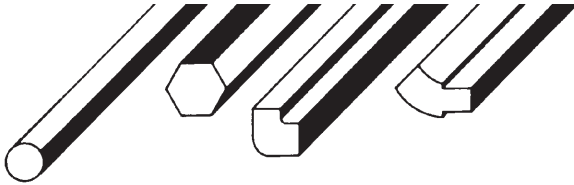

Shapes

The dies through which the billets are forced may be one of hundreds of shapes. Four of the most common shapes, used in the manufacture of Weatherhead fittings, are illustrated.



Saw and Machine

The cold bar stock is then cut into individual pieces for precision machining. After the part is machined, it is ready for the market as a strong, tough, high quality fitting. Only by using this process is it possible to get the big all-flat sides on elbows and tees, instead of the usual small wrench pads, or lack of flats altogether.

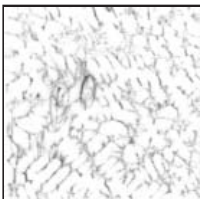

As Cast – 50x

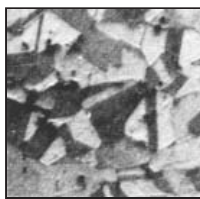

Hot Extruded – 200x

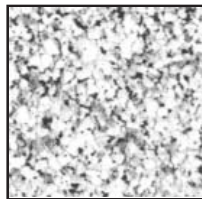

Cold Drawn – 200x

Microstructure

The photomicrographs illustrate the change in microstructure from the low strength low ductility dendritic structure of the cast billet, to the recrystallized structure of the hot extrusion, to the refined structure of the high strength high ductility cold drawn rod.

Inverted Flare

**Brass
Fittings**

 Refer to safety information regarding proper selection of tubing and tube fittings on page 1.

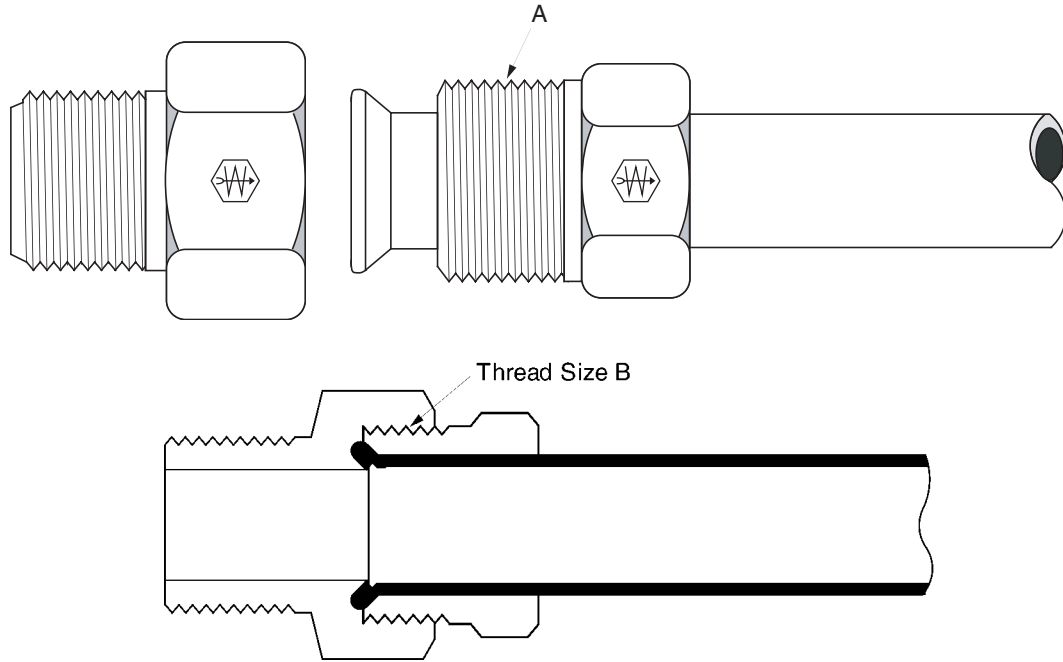

Tube O.D.	1/8	3/16	1/4	5/16	3/8	7/16	1/2	5/8	3/4	7/8	1
Thread Size-B	5/16-28	3/8-24	7/16-24	1/2-20	5/8-18	11/16-18	3/4-18	7/8-18	1-1/16-16	1-3/16-16	1-5/16-16

• Typical Application

Hydraulic brake, power steering, fuel lines and transmission cooler lines, LP and natural gas (special order).

• Pressure

Working pressure up to 2000 psi depending on tube size. Will withstand burst pressure of standard tubing - up to 5000 psi with Bundy-weld (double flared) and 3500 psi with copper tubing, depending on size.

• Vibration

Excellent resistance.

• Temperature Range

-65°F to +250°F (-53°C to +121°C) range at maximum operating pressures.

• Material

CA360 Brass.

• Used With

Copper, brass, aluminum and steel hydraulic tubing that can be flared. See page 28-32 for material compatibility.

• Advantages

Very low cost and reusable. Seats and threads are internal and protected. Compact, excellent vibration life. Short nut affords very close tube bends. Steel or brass tube nut.

• Conformance

Listed by Underwriter's Laboratories (available on special order) for fuel equipment, refrigeration and gas. Meets specifications and standards of ASA, ASME, SAE and MS (Military Standards).

• How to Order

Order individually by catalog number.

• NOTE:

Refer to current price list for availability of cataloged items. Configurations and dimensions subject to change without notice. Additional information can be found in SAE J512.

• Assembly Instructions

1. Cut tubing to desired length. Make sure all burrs are removed and the ends are cut square.
2. Slide nut on tube. Threaded end "A" of nut must face out.
3. Flare end of tube with a 45° flaring tool. See page 26 for flare data.
 - a. Measure flare diameter.
 - b. Examine flare for excessive thin out.
 - c. On thin wall, welded or brazed tubing, use double flare to prevent pinch-off and cracked flares.
4. Lubricate threads and assemble to fitting body. Nut should be turned hand tight.
5. Tighten assembly with a wrench until a solid feeling is encountered. From that point, apply a one-sixth turn.

NOTE: Do not over-torque as it may damage the fittings or split the tubing at the flare.

Label Set: **W-8022** (adhesive)
CL-490 (non-adhesive)

BRASS

Tube Nut

(Steel)
(Ref. SAE No. 040110)

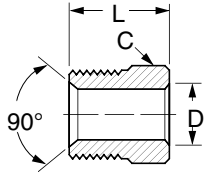

*3/8" Tube to 11/16-18 Male Thread

Tube O.D.	Catalog Number	Hex C	D	L
1/8	105x2	5/16	.132	.52
3/16	105x3	3/8	.196	.56
1/4	105x4	7/16	.259	.56
5/16	105x5	1/2	.321	.62
3/8	105x6	5/8	.384	.66
3/8	105x6x7*	11/16	.387	.66
7/16	105x7	11/16	.444	.68
1/2	105x8	3/4	.508	.74
5/8	105x10	7/8	.632	.80
3/4	105x12	1-1/16	.757	.88
7/8	105x14	1-3/16	.882	1.06
1	105x16	1-3/8	1.008	1.18

Tube Nut

(Brass)
(Ref. SAE No. 040110)

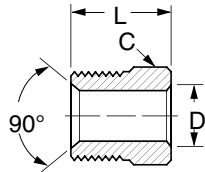

Tube O.D.	Catalog Number	Hex C	D	L
3/16	100x3	3/8	.196	.56
1/4	100x4	7/16	.259	.56
5/16	100x5	1/2	.321	.62
3/8	100x6	5/8	.384	.66
1/2	100x8	3/4	.508	.74

Plug

(Steel)
(Ref. SAE No. 040109)

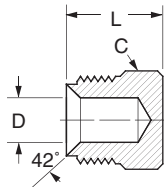
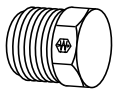

Tube O.D.	Catalog Number	Hex C	D	L
3/16	131x3	3/8	.188	.53
1/4	131x4	7/16	.188	.54
5/16	131x5	1/2	.250	.59
3/8	131x6	5/8	.312	.66

Tube Nut Long

(Steel)

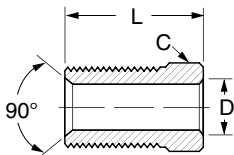
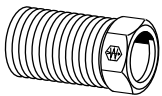

NOTE: Required for wheel cylinders with deep port connection.

Tube O.D.	Catalog Number	Hex C	D	L
3/16	7896x3	3/8	.196	.844
1/4	7896x4	7/16	.257	.812

Union

(Ref. SAE No. 040101)

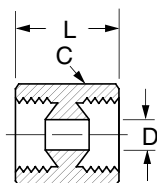
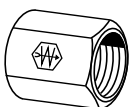

Tube O.D.	Catalog Number	Hex C	D	L
1/8	302x2	13/32	.078	.59
3/16	302x3	15/32	.125	.62
1/4	302x4	17/32	.188	.62
5/16	302x5	19/32	.219	.70
3/8	302x6	3/4	.281	.80
1/2	302x8	29/32	.406	.91

Inverted Flare

Brass Fittings

Adapter SAE 45° Flare to Inv. Flare

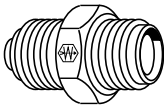

SAE Tube Size	Inverted Male	Catalog Number	Hex C	D	L
1/4	3/16	1518	7/16	.189	1.031
1/4	1/4	1522	7/16	.188	1.031
3/8	5/16	1553	5/8	.234	1.340
3/8	3/8	1563	5/8	.282	1.380
3/8	7/16	1554	11/16	.282	1.400

Male Connector (Ref. SAE No. 040102)

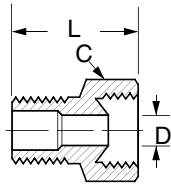
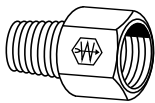

NOTE: Pipe end drill may be reduced or increased from seat dimension 'D'.

Tube O.D.	Male Pipe Thread	Catalog Number	Hex C	D	L
1/8	1/8	202x2	13/32	.078	.62
3/16	1/8	202x3	15/32	.125	.70
1/4	1/8	202x4	17/32	.188	.74
1/4	1/4	202x4x4	9/16	.188	.89
5/16	1/8	202x5	19/32	.219	.79
5/16	1/4	202x5x4	19/32	.220	.98
3/8	1/8	202x6x2	3/4	.281	.89
3/8	1/4	202x6	3/4	.281	1.03
3/8	3/8	202x6x6	3/4	.281	1.01
1/2	1/4	202x8x4	29/32	.406	1.08
1/2	3/8	202x8	29/32	.406	1.07
1/2	1/2	202x8x8	29/32	.406	1.26
5/8	1/2	202x10	1-1/16	.531	1.32
3/4	3/4	202x12	1-1/4	.625	1.39
7/8	3/4	202x14	1-3/8	.750	1.38

Female Connector (Ref. SAE No. 040103)

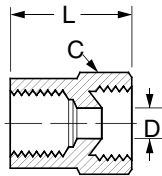
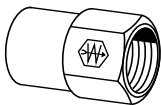

Tube O.D.	Fem. Pipe Thread	Catalog Number	Hex C	D	L
3/16	1/8	252x3	1/2	.125	.75
1/4	1/8	252x4	17/32	.188	.75
5/16	1/8	252x5	19/32	.219	.78
3/8	1/4	252x6♦	3/4	.281	1.03
1/2	3/8	252x8♦	29/32	.406	1.09

45° Male Elbow (Ref. SAE No. 040302)

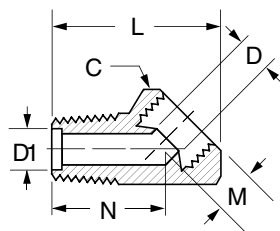
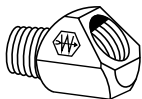

Tube O.D.	Male Pipe Thread	Catalog Number	Hex C	D	D1	L	M	N
3/16	1/8	352x3	17/32	.125	.156	.88	.25	.55
1/4	1/8	352x4	9/16	.188	.188	.94	.27	.58
5/16	1/8	352x5	5/8	.219	.203	1.00	.34	.56
5/16	1/4	352x5x4♦	5/8	.219	.203	1.16	.23	.83
3/8	1/8	352x6x2♦	25/32	.281	.281	1.34	.38	.69
3/8	1/4	352x6	25/32	.281	.219	1.34	.41	.84
1/2	3/8	352x8♦	7/8	.406	.375	1.44	.38	.91
5/8	1/2	352x10♦	1-1/16	.531	.500	1.75	.45	1.09

♦MTO - Made To Order

BRASS

Fuel Line Adapter

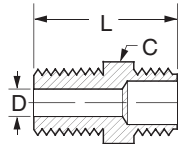

Inv. Tube Size	Male Pipe Thread	Catalog Number	Hex C	D	L
1/2-20	1/8	1514	1/2	.219	.90

90° Union Elbow (Ref. SAE No. 040201)

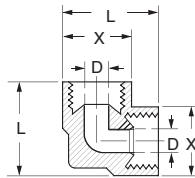
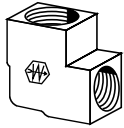

Tube O.D.	Catalog Number	D	L	X
1/4	502x4	.188	.77	.53
5/16	502x5♦	.219	.86	.59
3/8	502x6♦	.281	1.04	.72

90° Male Elbow (Ref. SAE No. 040202)

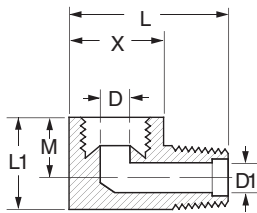
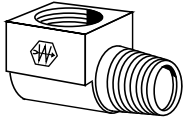

Tube O.D.	Male Pipe Thread	Catalog Number	D	D1	L	L1	M	X
1/8	1/8	402x2	.078	.116	.80	.47	.27	.42
3/16	1/8	402x3	.125	.125	.85	.47	.27	.47
1/4	1/8	402x4	.188	.177	.92	.55	.33	.53
1/4	1/8	431x4*	.188	.062	.91	.53	.33	.53
1/4	1/4	402x4x4	.188	.188	1.09	.58	.28	.56
5/16	1/8	402x5	.219	.219	.98	.67	.47	.59
5/16	1/4	402x5x4	.219	.219	1.16	.75	.45	.59
3/8	1/8	402x6x2	.281	.219	1.14	.75	.54	.76
3/8	1/4	402x6	.281	.281	1.32	.82	.53	.76
3/8	3/8	402x6x6	.281	.312	1.32	.84	.50	.75
1/2	1/4	402x8x4♦	.406	.281	1.47	.94	.59	.91
1/2	3/8	402x8	.406	.375	1.48	.94	.59	.91
1/2	1/2	402x8x8	.406	.406	1.67	1.09	.66	.91
5/8	3/8	402x10x6♦	.531	.437	1.62	1.11	.67	1.06
5/8	1/2	402x10♦	.531	.500	1.82	1.11	.67	1.06
3/4	1/2	402x12x8	.625	.531	2.01	1.30	.80	1.25
7/8	3/4	402x14	.750	.750	2.12	1.46	.94	1.38
1	1	402x16	.812	.812	2.44	1.70	1.02	1.50

* .062 dia. restricted hole through pipe end.
Available on special order with any restricted hole size up to .172 dia.

90° Female Elbow (Ref. SAE No. 040203)

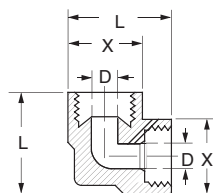
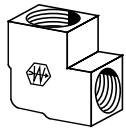

Tube O.D.	Fem. Pipe Thread	Catalog Number	D	L	X
3/16	1/8	452x3♦	.125	.81	.50
1/4	1/8	452x4	.188	.81	.53
5/16	1/8	452x5	.219	.88	.59
3/8	1/4	452x6	.281	1.05	.75

Inverted Flare

**Brass
Fittings**

Union Tee (Ref. SAE No. 040401)

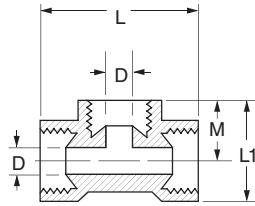
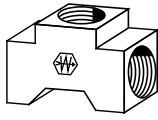

Tube O.D.	Catalog Number	D	L	L1	M
1/8	702x2	.078	.94	.53	.330
3/16	702x3	.125	1.09	.62	.390
1/4	702x4	.188	1.13	.69	.420
5/16	702x5	.219	1.25	.75	.450
3/8	702x6	.281	1.48	.94	.560
1/2	702x8♦	.406	1.76	1.12	.670
7/8	702x14	.750	2.37	1.62	.937

Male Run Tee (Ref. SAE No. 040424)

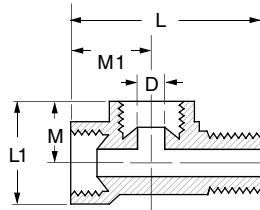
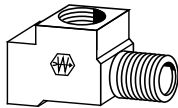

Tube O.D.	Male Pipe Thread	Catalog Number	D	L	L1	M	M1
3/16	1/8	752x3♦	.125	1.25	.62	.39	.53
1/4	1/8	752x4	.188	1.31	.69	.42	.56
5/16	1/8	752x5♦	.219	1.47	.75	.45	.62
3/8	1/4	752x6♦	.281	1.83	.94	.56	.75

Male Branch Tee (Ref. SAE No. 040425)

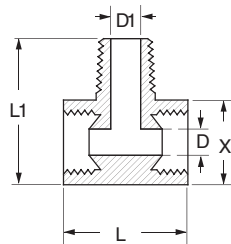
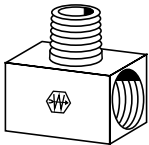

Tube O.D.	Male Pipe Thread	Catalog Number	D	D1	L	L1	X
3/16	1/8	602x3	.125	.219	.82	.84	.47
1/4	1/8	602x4	.188	.219	.84	.91	.53
5/16	1/8	602x5	.219	.219	.95	.97	.59
3/8	1/4	602x6	.281	.344	1.16	1.31	.75

Female Branch Tee (Ref. SAE No. 040427)

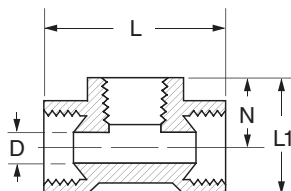
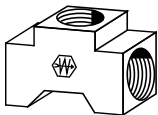

Tube O.D.	Fem. Pipe Thread	Catalog Number	D	L	L1	N
3/16	1/8	652x3	.125	1.10	.62	.39
1/4	1/8	652x4♦	.188	1.12	.69	.42
5/16	1/8	652x5♦	.219	1.26	.75	.45
3/8	1/4	652x6♦	.281	1.47	.94	.56
1/2	3/8	652x8♦	.406	1.75	1.12	.67

♦MTO - Made To Order

BRASS

 Refer to safety information regarding proper selection of tubing and tube fittings on page 1.

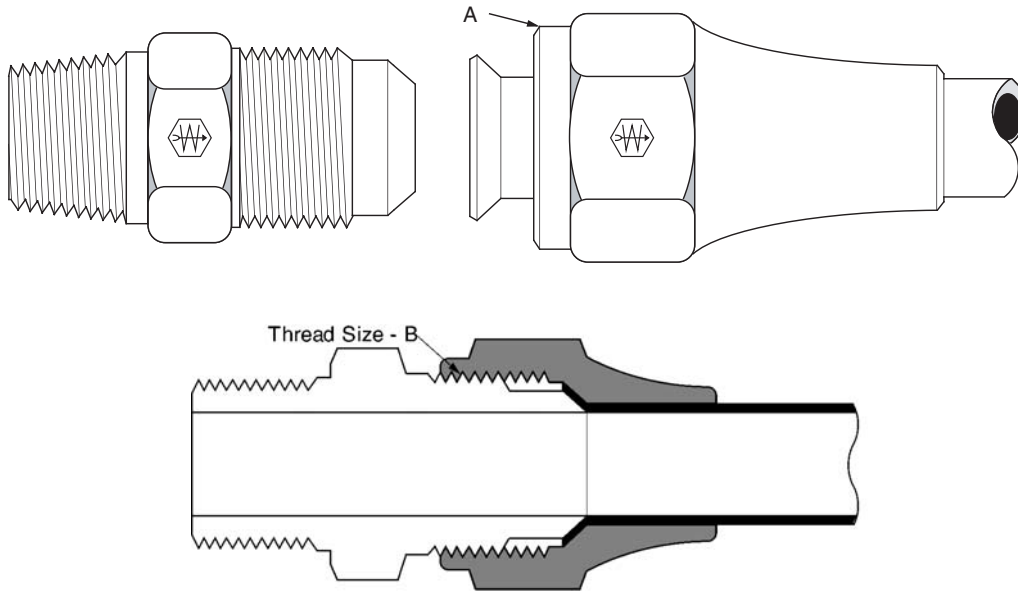

Tube O.D.	1/8	3/16	1/4	5/16	3/8	7/16	1/2	5/8	3/4
Thread Size-B	5/16-24	3/8-24	7/16-20	1/2-20	5/8-18	11/16-16	3/4-16	7/8-14	1-1/16-14

• **Typical Application**

LP and natural gas, flammable liquids (special order), instrumentation, refrigeration, power steering, hydraulic and pneumatic systems.

• **Pressure**

Working pressure up to 2000 psi depending on tube size. Will withstand burst pressure of standard tubing - up to 5000 psi with Bundy-weld (double flared) and 3500 psi with copper tubing, depending on size.

• **Vibration**

Good resistance - use long nut when greater vibration resistance is required.

• **Temperature Range**

-65°F to +250°F (-53°C to +121°C) range at maximum operating pressures.

• **Material**

CA360 Brass.

• **Used With**

Copper, brass, aluminum and steel hydraulic tubing that can be flared. See page 28-32 for material compatibility.

• **Advantages**

Low cost and reusability, long or short nut. Good resistance to vibration.

• **Conformance**

Listed by Underwriter's Laboratories (available on special order) for flammable liquids, refrigeration and gas. Meets specifications and standards of ASA, ASME, SAE and MS (Military Standards).

• **How to Order**

Order individually by catalog number.

• **NOTE**

Refer to current price list for availability of cataloged items. Configurations and dimensions subject to change without notice. Quotations of non-stock items available upon request. Additional information can be found in SAE J512.

• **Assembly Instructions**

1. Cut tubing to desired length. Make sure all burrs are removed and the ends are cut square.
2. Slide nut on tube. Threaded end "A" of nut must face out.
3. Flare end of tube with a 45° flaring tool. See page 26 for flare data.
 - a. Measure flare diameter.
 - b. Examine flare for excessive thin out.
4. Lubricate threads and assemble to fitting body. Nut should be turned hand tight.
5. Tighten assembly with a wrench until a solid feeling is encountered. From that point, apply a one-sixth turn.

NOTE: Do not over-torque as it may damage the fitting or split the tubing at the flare.

Label Set: **W-8022** (adhesive)
CL-490 (non-adhesive)

SAE 45° Flare

**Brass
Fittings**

Nut (Ref. SAE No. 010110)

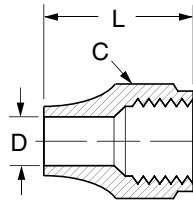

Tube O.D.	Catalog Number	Hex C	D	L
1/8	1110x2	3/8	.133	.50
3/16	1110x3	7/16	.195	.62
1/4	1110x4	9/16	.258	.75
5/16	1110x5	5/8	.320	.88
3/8	1110x6	3/4	.383	1.00
7/16	1110x7♦	13/16	.445	1.06
1/2	1110x8	7/8	.508	1.12
5/8	1110x10	1-1/16	.633	1.31
3/4	1110x12♦	1-1/4	.758	1.50

Long Nut (Ref. SAE No. 010111)

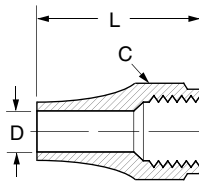
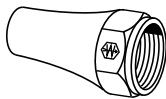

Tube O.D.	Catalog Number	Hex C	D	L
3/16	41x3	7/16	.195	.81
1/4	41x4	9/16	.258	.94
5/16	41x5	5/8	.320	1.12
3/8	41x6	3/4	.383	1.31
1/2	41x8	7/8	.508	1.62
5/8	41x10♦	1-1/16	.633	1.88

Cap

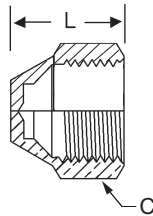
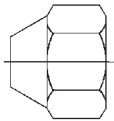

Tube O.D.	Catalog Number	Hex C	L
1/8	40x2	7/16	.40
3/16	40x3	1/2	.47
1/4	40x4	7/16	.53
5/16	40x5	5/8	.62
3/8	40x6	3/4	.69
1/2	40x8	7/8	.84
5/8	40x10	1-1/16	.97
3/4	40x12	1-5/16	1.09

Plug (Ref. SAE No. 010109)

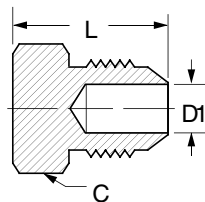
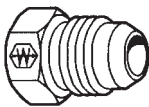

Tube O.D.	Catalog Number	Hex C	L	D1 (opt.)
1/8	39x2	5/16	.47	.079
3/16	39x3	3/8	.58	.126
1/4	39x4	7/16	.69	.189
5/16	39x5	1/2	.79	.220
3/8	39x6	5/8	.88	.282
1/2	39x8	3/4	1.06	.408
5/8	39x10	7/8	1.19	.502
3/4	39x12	1-1/16	1.31	.627

Union (Ref. SAE No. 010101)

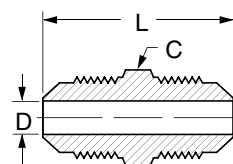
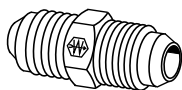

Tube O.D.	Catalog Number	Hex C	D	L
1/8	42x2♦	5/16	.078	.92
3/16	42x3	3/8	.125	1.06
1/4	42x4	7/16	.188	1.19
5/16	42x5	1/2	.219	1.34
3/8	42x6	5/8	.281	1.50
1/2	42x8	3/4	.406	1.81
5/8	42x10	7/8	.500	2.12
3/4	42x12♦	1-1/16	.625	2.44

♦MTO - Made To Order

BRASS

Male Connector
(Ref. SAE No. 010102)

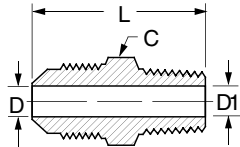
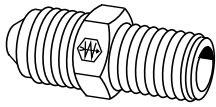

*Counterbore is optional.

Tube O.D.	Male Pipe Thread	Catalog Number	Hex C	D	D1	L
1/8	1/8	48x2	7/16	.078	.219	.90
3/16	1/8	48x3	7/16	.125	.219	1.00
1/4	1/8	48x4	7/16	.188	.188	1.06
1/4	1/4	48x4x4	9/16	.188	.312	1.26
5/16	1/8	48x5	1/2	.219	.219	1.16
5/16	1/4	48x5x4	9/16	.219	.219	1.34
3/8	1/8	48x6x2	5/8	.281	.219	1.25
3/8	1/4	48x6	5/8	.281	.281	1.44
3/8	3/8	48x6x6	11/16	.281	.281	1.44
3/8	1/2	48x6x8	7/8	.281	.562*	1.69
1/2	1/4	48x8x4	3/4	.406	.312	1.62
1/2	3/8	48x8	3/4	.406	.406	1.62
1/2	1/2	48x8x8	7/8	.406	.562	1.81
5/8	3/8	48x10x6	7/8	.500	.406	1.81
5/8	1/2	48x10	7/8	.500	.500	2.00
3/4	1/2	48x12	1-1/16	.625	.562	2.18
3/4	3/4	48x12x12	1-1/16	.625	.625	2.18

Female Connector
(Ref. SAE No. 010103)

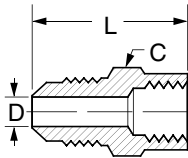
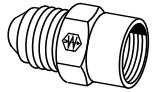

Tube O.D.	Fem. Pipe Thread	Catalog Number	Hex C	D	L
3/16	1/8	46x3♦	9/16	.125	.97
1/4	1/8	46x4	9/16	.188	1.03
1/4	1/4	46x4x4	11/16	.188	1.25
5/16	1/8	46x5	9/16	.219	1.06
5/16	1/4	46x5x4♦	11/16	.219	1.28
3/8	1/8	46x6x2♦	5/8	.281	1.12
3/8	1/4	46x6	11/16	.281	1.31
3/8	3/8	46x6x6	13/16	.281	1.38
3/8	1/2	46x6x8♦	1	.281	1.62
1/2	1/4	46x8x4♦	3/4	.406	1.41
1/2	3/8	46x8	13/16	.406	1.50
1/2	1/2	46x8x8♦	1	.406	1.75
5/8	3/8	46x10x6♦	7/8	.500	1.59
5/8	1/2	46x10♦	1	.500	1.81
5/8	3/4	46x10x12♦	1-1/4	.500	1.90

Male Ball Check Connector

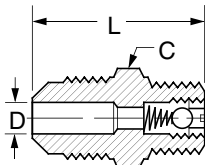
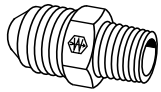

Ball & Spring position may be reversed to change flow/check direction. Min pressure 3 psi.

Tube O.D.	Male Pipe Thread	Catalog Number	Hex C	D	L
1/4	1/8	43x4	7/16	.125	1.06
3/8	1/4	43x6	5/8	.219	1.31

45° Male Elbow
(Ref. SAE No. 010302)

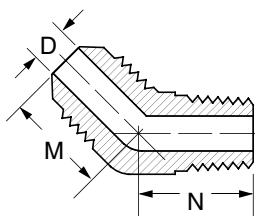
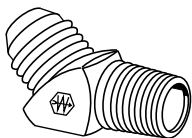

Tube O.D.	Male Pipe Thread	Catalog Number	D	M	N
1/4	1/8	54x4	.188	.67	.64
1/4	1/4	54x4x4	.188	.73	.87
5/16	1/8	54x5	.219	.78	.64
3/8	1/4	54x6	.281	.89	.86
3/8	3/8	54x6x6♦	.281	.93	.95
1/2	3/8	54x8	.406	1.06	.95
1/2	1/2	54x8x8	.406	1.12	1.17
5/8	3/8	54x10x6	.500	1.23	.98
5/8	1/2	54x10	.500	1.23	1.17

SAE 45° Flare

**Brass
Fittings**

45° Elbow - Female 45° Flare Swivel to Male SAE 45° (Steel)

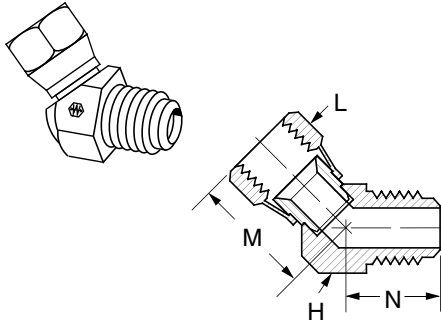

Tube O.D.	Catalog Number	M	N	Hex H	Hex L
3/8	9154x6x6	1.14	1.40	3/4	3/4
1/2	9154x8x8	1.04	1.76	1	7/8
5/8	9154x10x10	1.16	1.92	1-1/4	1

AC Type Adapter

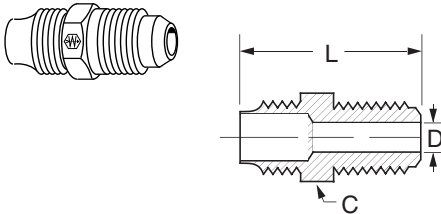

Tube Size	SAE Tube Size	Catalog Number	Hex C	D	L
1/4	1/4	1521	7/16	.188	1.094

Adapter SAE 45° Flare to Inv. Flare

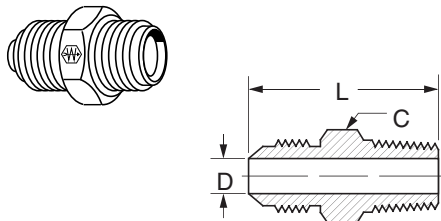

SAE Tube Size	Inverted Male	Catalog Number	Hex C	D	L
1/4	3/16	1518	7/16	.189	1.031
1/4	1/4	1522	7/16	.188	1.031
3/8	5/16	1553	5/8	.234	1.340
3/8	3/8	1563	5/8	.282	1.380
3/8	7/16	1554	11/16	.282	1.400

90° Union Elbow (Ref. SAE No. 010201)

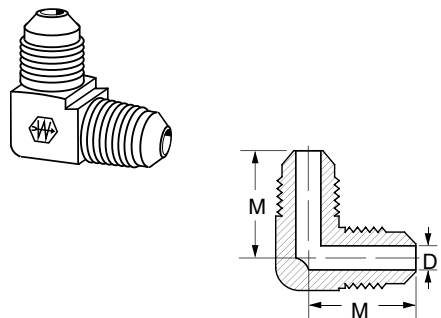

Tube O.D.	Catalog Number	D	M
1/4	55x4♦	.188	.86
5/16	55x5♦	.219	.91
3/8	55x6♦	.281	1.04
1/2	55x8	.406	1.20
5/8	55x10♦	.500	1.41
3/4	55x12♦	.625	1.64

♦MTO - Made To Order

B
R
A
S
S

90° Male Elbow
(Ref. SAE No. 010202)

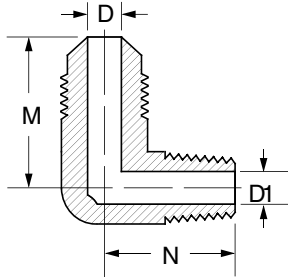
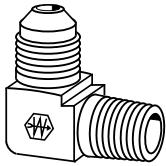

Tube O.D.	Male Pipe Thread	Catalog Number	D	D1	M	N
1/8	1/8	49x2	.078	.219	.62	.69
3/16	1/8	49x3	.125	.219	.75	.75
1/4	1/8	49x4	.188	.219	.81	.76
1/4	1/4	49x4x4	.188	.312	.88	.94
1/4	3/8	49x4x6	.188	.375	.94	1.03
5/16	1/8	49x5	.219	.219	.91	.78
5/16	1/4	49x5x4	.219	.312	.95	.92
3/8	1/8	49x6x2	.281	.219	1.03	.91
3/8	1/4	49x6	.281	.312	.97	1.06
3/8	3/8	49x6x6	.281	.406	1.06	1.09
3/8	1/2	49x6x8	.281	.438	1.16	1.28
1/2	1/4	49x8x4	.406	.281	1.22	1.19
1/2	3/8	49x8	.406	.406	1.22	1.12
1/2	1/2	49x8x8	.406	.406	1.26	1.36
5/8	3/8	49x10x6	.500	.410	1.41	1.23
5/8	1/2	49x10	.500	.562	1.41	1.38
3/4	1/2	49x12	.625	.531	1.62	1.50
3/4	3/4	49x12x12	.625	.750	1.59	1.62

90° Female Elbow
(Ref. SAE No. 010203)

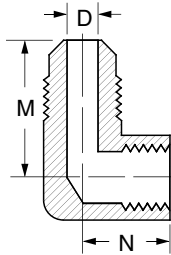
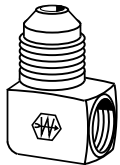

Tube O.D.	Fem. Pipe Thread	Catalog Number	D	M	N
1/4	1/8	50x4	.188	.88	.47
1/4	1/4	50x4x4	.188	.97	.66
5/16	1/4	50x5x4♦	.219	1.03	.66
3/8	1/4	50x6	.281	1.09	.69
3/8	3/8	50x6x6♦	.281	1.16	.69
1/2	3/8	50x8♦	.406	1.28	.75
1/2	1/2	50x8x8♦	.406	1.38	.94
5/8	1/2	50x10	.500	1.50	1.00
5/8	3/4	50x10x12♦	-	-	-

90° Elbow - 45° Flare Female Swivel to Male SAE 45°
(Steel)

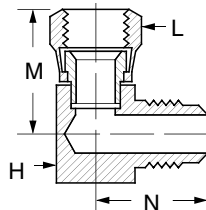

Tube O.D.	Catalog Number	M	N	Hex H	Hex L
3/8	9151x6x6	1.09	1.00	3/4	3/4
1/2	9151x8x8	1.43	1.25	1	7/8
5/8	9151x10x10	1.60	1.44	1-1/4	1

SAE 45° Flare

**Brass
Fittings**

Union Tee (Ref. SAE No. 010401)

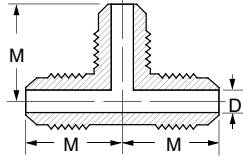
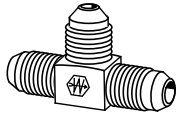

Tube O.D.	Catalog Number	D	M
3/16	44x3♦	.125	.73
1/4	44x4	.188	.86
5/16	44x5♦	.219	.89
3/8	44x6♦	.281	1.04
1/2	44x8	.406	1.20
5/8	44x10♦	.500	1.42

Male Run Tee (Ref. SAE No. 010424)

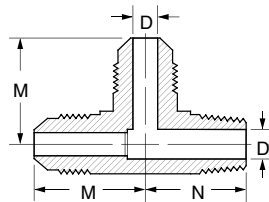
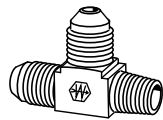

Tube O.D.	Male Pipe Thread	Catalog Number	D	D1 Opt.	M	N
1/4	1/8	51x4	.188	.219	.86	.76
5/16	1/4	51x5x4x5♦	.219	.312	.97	.94
3/8	1/4	51x6♦	.281	.281	1.04	1.04
3/8	3/8	51x6x6x6♦	.281	.406	1.06	1.09
1/2	3/8	51x8♦	.406	.406	1.20	1.10
1/2	1/2	51x8x8x8♦	.406	.562	1.28	1.38
5/8	1/2	51x10♦	.500	.500	1.42	1.38

Male Branch Tee (Ref. SAE No. 010425)

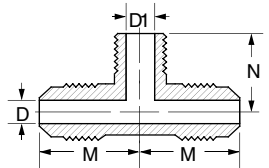
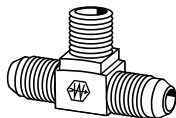

Tube O.D.	Male Pipe Thread	Catalog Number	D	D1	M	N
1/4	1/8	45x4	.188	.219	.81	.78
1/4	1/4	45x4x4x4♦	.188	.312	.91	.94
5/16	1/4	45x5x5x4♦	.219	.312	.97	.94
3/8	1/4	45x6♦	.281	.344	1.00	1.06
3/8	3/8	45x6x6x6♦	.281	.406	1.06	1.09
1/2	3/8	45x8♦	.406	.406	1.22	1.12
1/2	1/2	45x8x8x8♦	.406	.562	1.28	1.38
5/8	1/2	45x10♦	.500	.562	1.41	1.38
3/4	1/2	45x12♦	.625	.562	1.62	1.50

Adapter Tee (Female to Male Pipe on Run)

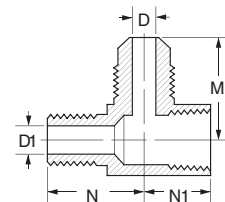
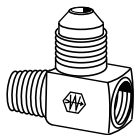

Tube O.D.	M&F Pipe Thread	Catalog Number	D	D1	M	N	N1
1/4	1/8	56x4♦	.188	.188	.78	.76	.46

♦MTO - Made To Order

BRASS

 Refer to safety information regarding proper selection of tubing and tube fittings on page 1.

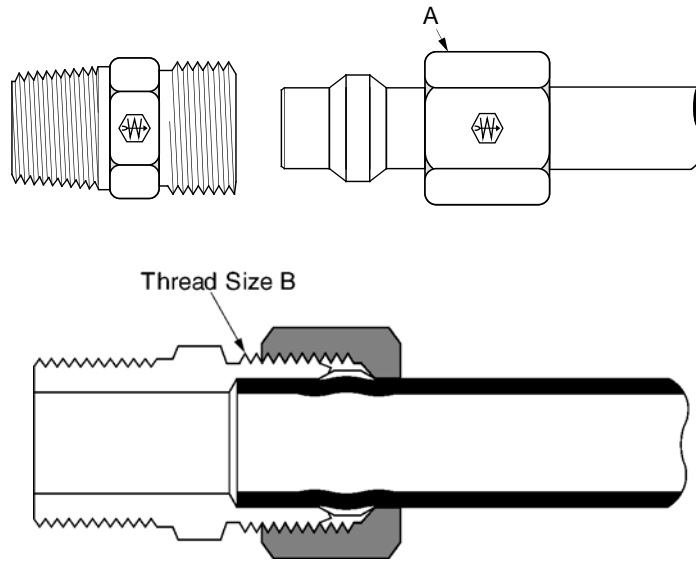

Tube O.D.	1/8	3/16	1/4	5/16	3/8	7/16	1/2	5/8	3/4	1
Thread Size-B	5/16-24	3/8-24	7/16-24	1/2-24	9/16-24	5/8-24	11/16-20	13/16-18	1-18	1-1/4-18

• Typical Application

Instrumentation, hydraulic and pneumatic systems.

• Pressure

Working pressure up to 2000 psi with a 4:1 safety factor depending on tube size. When using plastic tubing, use the working pressure for type used.

• Vibration

Fair resistance - use long nut when greater vibration resistance is needed.

• Temperature Range

-65°F to +250°F (-53°C to +121°C) with metal tubing. When using compatible plastic tubing do not exceed the tubing temperature range. (Refer to tubing temperature range.)

• Material

CA360 Brass.

• Used With

Aluminum, copper and Weatherhead plastic tubing.
Plastic tubing, except for PT230, requires 2030x insert. Not recommended for steel tubing. See page 28-32 for material compatibility, and pages 33-35 for plastic tubing.

• Advantages

Low cost. Easy to assemble, no flaring. Available with long or short nut. Broad selection of styles and sizes.

• Conformance

Listed by Underwriter's Laboratories (available on special order) for flammable liquids. Meets specifications and standards of ASA, ASME and SAE.

• How to Order

Compression fittings are ordered as complete assemblies (body, nut and sleeve). To order assembly supplied with long nuts, simply add the prefix "1" to the catalog number. Example: 68x4 with long nut becomes 168x4. Nuts and sleeves can be ordered separately by catalog number. To order bodies only (less nut and sleeve), prefix catalog number with letter "B". Example: B68x4.

• NOTE

Refer to current price list for availability of cataloged items. Quotations and delivery of non-stock items supplied on request. Configurations and dimensions subject to change without notice. Additional information can be found in SAE J512.

• Assembly Instructions

1. Cut tubing to desired length.
2. Slide nut and then sleeve on tube. Threaded end "A" of nut must face toward fitting.
3. Insert tubing into fitting body. Be sure tubing is bottomed on fitting shoulder.
4. Lubricate threads and assemble nut to fitting body.
5. Tighten nut hand tight. From that point, tighten with a wrench the number of turns indicated in the chart below.

Tube Size	Additional Turns From Hand Tight
1/8" thru 1/4"	1-1/4
5/16"	1-3/4
3/8" thru 1"	2-1/4

Label Set: **W-8022** (adhesive)
CL-490 (non-adhesive)

Compression

Brass Fittings

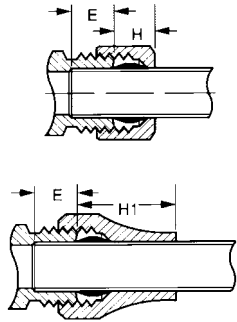

NOTE: H and H1 are hand tight dimensions.

Tube O.D.	E Tube Stop Depth	H	H1 (Long Nut)
1/8	.19	.23	—
3/16	.22	.25	.47
1/4	.25	.29	.56
5/16	.28	.30	.66
3/8	.31	.27	.70
1/2	.38	.42	.88
5/8	.38	.42	.92
3/4	.44	.49	1.18

Tube Support for Plastic Tubing

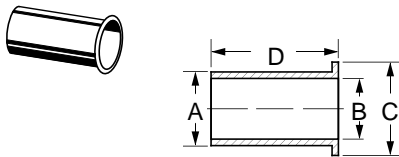

Use only with PT200 and PT240 Tubing.

* For Tubing with .126 I.D./0.062 wall thickness.

** For tubing with .170 I.D./0.040 wall thickness.

Tube O.D.	Catalog Number	Dia. A	Dia. B	Dia. C	Length D
1/4	2030x4*	1/8	3/32	11/64	19/32
1/4	2030x44**	11/64	9/64	7/32	17/32
5/16	2030x5	3/16	5/32	15/64	5/8
3/8	2030x6	1/4	7/32	11/32	41/64
1/2	2030x8	3/8	11/32	7/16	13/16
5/8	2030x10	1/2	29/64	35/64	13/16
3/4	2030x12	9/16	33/64	11/16	1-1/32

Compression Sleeve (Ref. SAE No. 060115)

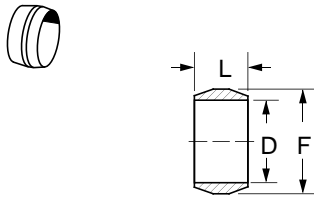

Tube O.D.	Catalog Number	D	F	L
1/8	60x2	.13	.19	.19
3/16	60x3	.19	.27	.22
1/4	60x4	.26	.34	.25
5/16	60x5	.32	.41	.25
3/8	60x6	.38	.47	.25
7/16	60x7	.44	.53	.31
1/2	60x8	.51	.59	.38
5/8	60x10	.63	.72	.38
3/4	60x12♦	.76	.88	.44

Nut (Ref. SAE No. 060110)

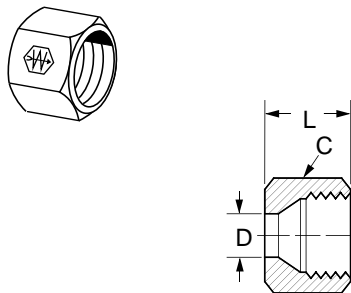

Tube O.D.	Catalog Number	Hex C	D	L
1/8	61x2	3/8	.13	.38
3/16	61x3	7/16	.19	.41
1/4	61x4	1/2	.26	.44
5/16	61x5	9/16	.32	.44
3/8	61x6	5/8	.38	.47
7/16	61x7	11/16	.44	.50
1/2	61x8	13/16	.51	.62
5/8	61x10	15/16	.63	.62
3/4	61x12♦	1-3/16	.76	.69

♦MTO - Made To Order

Long Nut

(Ref. SAE No. 060111)

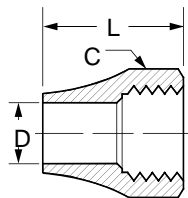
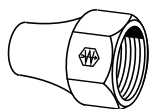

Tube O.D.	Catalog Number	Hex C	D	L
3/16	1611x3	7/16	.193	.62
1/4	1611x4	9/16	.260	.75
5/16	1611x5♦	5/8	.320	.84
3/8	1611x6	11/16	.380	.88
1/2	1611x8♦	13/16	.510	1.06
5/8	1611x10♦	15/16	.637	1.08
3/4	1611x12♦	1-1/8	.760	1.38
1	1611x16♦	1-3/8	1.020	1.59

Bulkhead Nut

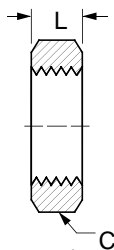

Used on **74x** Bulkhead Unions. Ref. page 51.

Tube O.D.	Catalog Number	Hex C	L	Thread Size
1/4	0102x4	9/16	.25	7/16-24
5/16	0102x5	5/8	.25	1/2-24
3/8	0102x6	11/16	.25	9/16-24
1/2	0102x8	15/16	.38	11/16-20

Union

(Ref. SAE No. 060101BA)

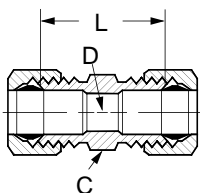
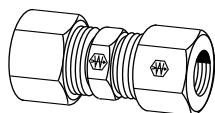

Assembly with long nut **162x**

Tube O.D.	Catalog Number	Hex C	D	L
1/8	62x2	5/16	.094	.66
3/16	62x3	3/8	.125	.76
1/4	62x4	7/16	.188	.79
5/16	62x5	1/2	.250	.88
3/8	62x6	9/16	.312	.97
1/2	62x8	11/16	.406	1.10
5/8	62x10	13/16	.500	1.25
3/4	62x12♦	1	.562	1.44

Male Connector

(Ref. SAE No. 060102BA)

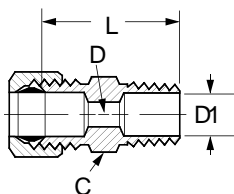
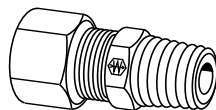

Assembly with long nut **168x**

*Available only as assembly with long nut.

Tube O.D.	Male Pipe Thread	Catalog Number	Hex C	D	D1 Opt.	L
1/8	1/16	68x2x1	3/8	.094	—	.78
1/8	1/8	68x2	7/16	.094	.094	.78
3/16	1/8	68x3	7/16	.125	.125	.84
3/16	1/4	68x3x4♦	9/16	.125	.125	1.03
1/4	1/8	68x4	7/16	.188	.188	.88
1/4	1/4	68x4x4	9/16	.188	.312	1.06
5/16	1/8	68x5	1/2	.250	.234	.91
5/16	1/4	68x5x4	9/16	.250	.250	1.09
3/8	1/8	68x6x2	9/16	.312	.250	.97
3/8	1/4	68x6	9/16	.312	.312	1.17
3/8	3/8	68x6x6	11/16	.312	.312	1.16
3/8	1/2	68x6x8	7/8	.312	.562	1.34
7/16	1/4	68x7♦	5/8	.312	.312	1.19
1/2	1/4	68x8x4	11/16	.406	.281	1.22
1/2	3/8	68x8	11/16	.406	.406	1.22
1/2	1/2	68x8x8	7/8	.406	.406	1.41
5/8	1/2	68x10	7/8	.500	.500	1.50
3/4	1/2	68x12♦	1	.562	.562	1.62
3/4	3/4	68x12x12♦	1-1/16	.562	.875	1.62

Female Connector (Ref. SAE No. 060103BA)

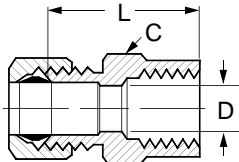
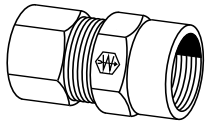

Assembly with long nut **166x**

Tube O.D.	Fem. Pipe Thread	Catalog Number	Hex C	D	L
1/8	1/8	66x2	9/16	.094	.75
3/16	1/8	66x3	9/16	.125	.78
1/4	1/8	66x4	9/16	.188	.78
1/4	1/4	66x4x4	11/16	.188	1.03
5/16	1/8	66x5	9/16	.250	.81
5/16	1/4	66x5x4♦	11/16	.250	1.03
3/8	1/8	66x6x2	9/16	.312	.84
3/8	1/4	66x6	11/16	.312	1.06
1/2	3/8	66x8	13/16	.406	1.12
5/8	1/2	66x10♦	1	.500	1.38

Male Ball Check Connector

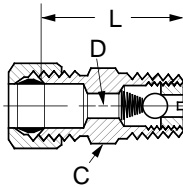
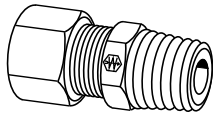

Assembly with long nut **163x**. Min. working pressure 3 psi. Ball and spring position may be reversed to change flow/check direction. Ball check valves are neither tested nor adjusted prior to sale.

Tube O.D.	Male Pipe Thread	Catalog Number	Hex C	D	L
1/4	1/8	63x4	7/16	.125	.88
5/16	1/8	63x5	1/2	.125	.91
3/8	1/4	63x6	9/16	.219	1.16

Bulkhead Union

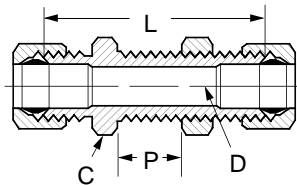
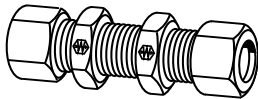

Assembly with long nut **174x**
For Bulkhead Nuts, ref. page 50, included with assembly.

Tube O.D.	Catalog Number	Hex C	D	L	Max. P
1/4	74x4	9/16	.188	1.57	.52
3/8	74x6♦	11/16	.312	1.76	.55

♦MTO - Made To Order

90° Male Elbow
(Ref. SAE No. 060202BA)

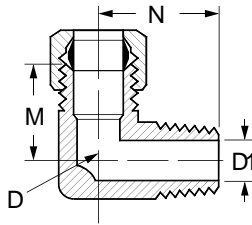
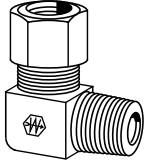

Assembly with long nut **169x**
*Available only as assembly with long nuts

Tube O.D.	Male Pipe Thread	Catalog Number	D	D1	M	N
1/8	1/16	69x2x1	.104	.125	.54	.66
1/8	1/8	69x2	.094	.219	.60	.67
3/16	1/8	69x3	.125	.219	.62	.69
1/4	1/8	69x4	.188	.219	.62	.75
1/4	1/4	69x4x4	.188	.188	.62	.75
5/16	1/8	69x5	.250	.234	.62	.75
5/16	1/4	69x5x4	.250	.312	.69	.84
3/8	1/8	69x6x2	.312	.234	.69	.69
3/8	1/4	69x6	.312	.344	.75	.94
3/8	3/8	69x6x6	.312	.438	.84	.94
3/8	1/2	69x6x8	.312	.531	1.06	1.12
7/16	1/4	69x7♦	.312	.312	.84	1.00
1/2	1/4	69x8x4	.406	.312	.84	.94
1/2	3/8	69x8	.406	.406	.94	1.12
1/2	1/2	69x8x8	.406	.531	.94	1.31
5/8	1/2	69x10	.500	.562	1.06	1.31
3/4	1/2	69x12♦	.562	.562	1.19	1.50
3/4	3/4	69x12x12♦	.562	.562	1.19	1.31
1	1	169x16*	.875	.938	1.31	1.62

90° Union Elbow
(Ref. SAE No. 060201BA)

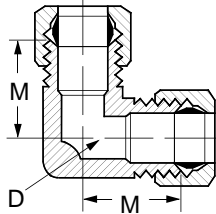
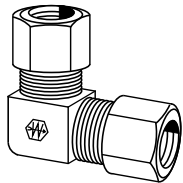

Assembly with long nut **165x**

Tube O.D.	Catalog Number	D	M
3/16	65x3♦	.125	.59
1/4	65x4	.188	.60
5/16	65x5	.250	.62
3/8	65x6	.312	.73
1/2	65x8	.406	.94

90° Female Elbow
(Ref. SAE No. 060203BA)

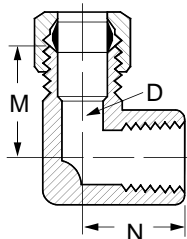
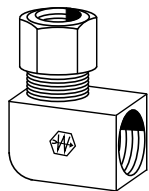

Assembly with long nut **170x**

Tube O.D.	Fem. Pipe Thread	Catalog Number	D	M	N
3/16	1/8	70x3	.125	.69	.56
1/4	1/8	70x4	.188	.69	.56
3/8	1/4	70x6♦	.312	.81	.75
1/2	3/8	70x8♦	.406	1.00	.88

Union Tee (Ref. SAE No. 060401BA)

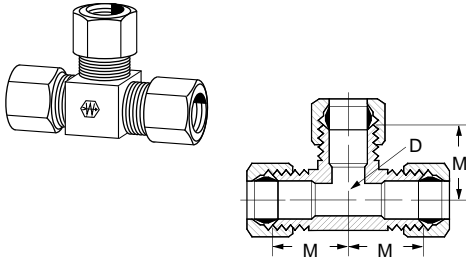

Assembly with long nut **164x**

Tube O.D.	Catalog Number	D	M
3/16	64x3	.125	.60
1/4	64x4	.188	.62
5/16	64x5	.250	.60
3/8	64x6	.312	.73
1/2	64x8	.406	.94

Male Run Tee (Ref. SAE No. 060424BA)

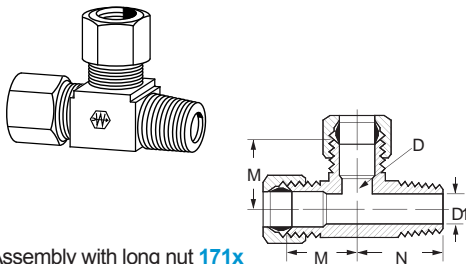

Assembly with long nut **171x**
* Optional Counterbore

Tube O.D.	Male Pipe Thread	Catalog Number	D	D1	M	N
3/16	1/8	71x3	.125	.219*	.64	.68
1/4	1/8	71x4	.188	.219*	.64	.73
1/4	1/4	71x4x4x4*	.188	.281*	.66	.80
5/16	1/8	71x5*	.250	.219*	.65	.72
3/8	1/4	71x6	.312	.344*	.75	.94

Male Branch Tee (Ref. SAE No. 060425BA)

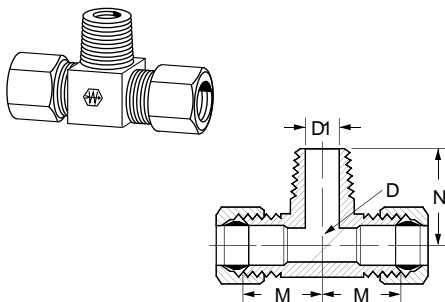

Assembly with long nut **172x**

Tube O.D.	Male Pipe Thread	Catalog Number	D	D1	M	N
3/16	1/8	72x3*	.125	.219	.62	.69
1/4	1/8	72x4	.188	.219	.64	.73
1/4	1/4	72x4x4x4	.188	.281	.78	.85
5/16	1/8	72x5	.250	.234	.66	.70
3/8	1/4	72x6	.312	.344	.78	.91
1/2	3/8	72x8	.406	.406	.96	1.09

Adapter Tee (Female to Male Pipe on Run)

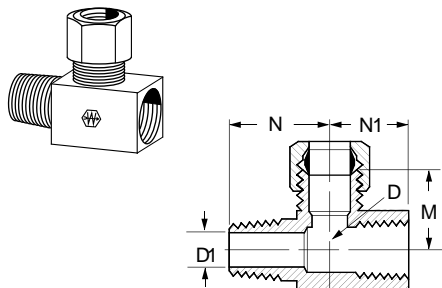

Assembly with long nut **176x**

Tube O.D.	M&F Pipe Thread	Catalog Number	D	D1	M	N	N1
1/4	1/8	76x4*	.188	.219	.59	.63	.47

*MTO - Made To Order

⚠ Refer to safety information regarding proper selection of tubing and tube fittings on page 1.

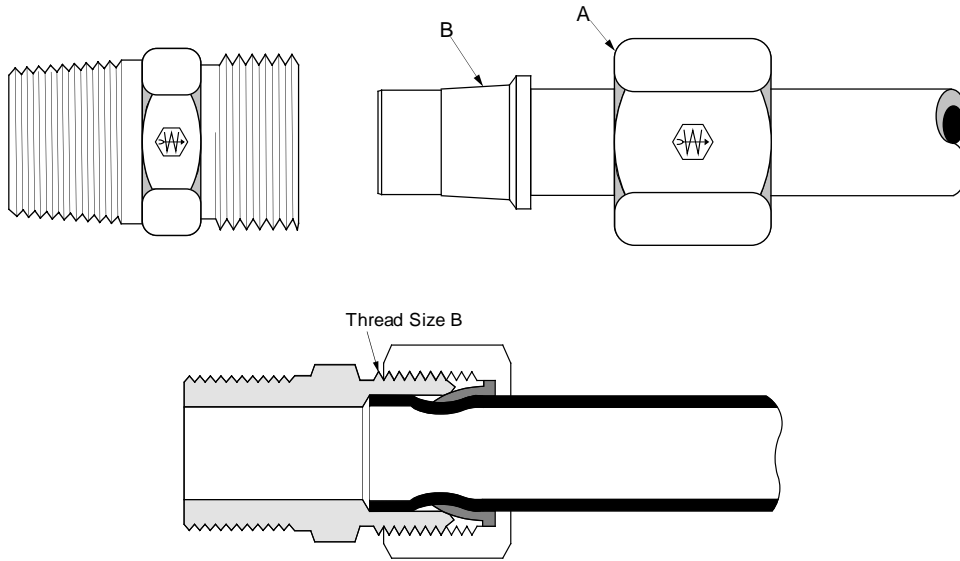

Tube O.D.	1/8	3/16	1/4	5/16	3/8	7/16	1/2	5/8	3/4	1
Thread Size-B	5/16-24	3/8-24	7/16-24	1/2-24	9/16-24	5/8-24	11/16-20	13/16-18	1-18	1-1/4-18

• Typical Application

Instrumentation, hydraulic and pneumatic systems.

• Pressure

Working pressure up to 2000 psi with a 4:1 safety factor depending on tube size. When using plastic tubing, use the working pressure for type used.

• Vibration

Good resistance - use long nut when greater vibration resistance is needed.

• Temperature Range

-65°F to +250°F (-53°C to +121°C) with metal tubing. When using compatible plastic tubing do not exceed the tubing temperature range. (Refer to tubing temperature range.)

• Material

CA360 Brass.

• Used With

Aluminum, copper and Weatherhead plastic tubing.
Plastic tubing, except for PT230, requires 2030x insert. Not recommended for steel tubing. See page 28-32 for material compatibility, and pages 33-35 for plastic tubing.

• Advantages

Selfaligning - no need to disassemble fitting to line up sleeve on tube. Low cost. Easy to assemble, no flaring. Available with long or short nut. Broad selection of styles and sizes.

• Conformance

An exclusive item with Weatherhead, user approvals only.

• How to Order

Selfalign fittings are ordered as complete assemblies (body, nut and sleeve). To order assembly supplied with long nuts, simply add the prefix "1" to the catalog number. Example: 681x4 with long nut becomes 1681x4. Nuts and sleeves can be ordered separately by catalog number. To order bodies only (less nut and sleeve), prefix catalog number with the letter "B" and drop suffix number. Example: B68x4.

• NOTE

Refer to current price list for availability of cataloged items. Quotations and delivery of non-stock items supplied on request. Configurations and dimensions subject to change without notice.

• Assembly Instructions

1. Cut tubing to desired length.
2. Slide nut and then sleeve on tube. Threaded end of nut "A" and small end of sleeve "B" must face toward fitting.
3. Insert tubing into fitting body. Be sure tubing is bottomed on fitting shoulder.
4. Lubricate threads and assemble nut to fitting body.
5. Tighten with wrench to the "ring grip" point.
 - a. Ring Grip is the point when the cutting edge of the sleeve grips the tube. This is determined by turning tube slowly but firmly by hand while tightening the nut with a wrench until tube can no longer be turned by hand and a sharp increase in torque is noticed.
6. Tighten additional turns past "ring grip" as indicated on chart. Ref. to page 55.

Label Set: **CL-500** (non-adhesive)

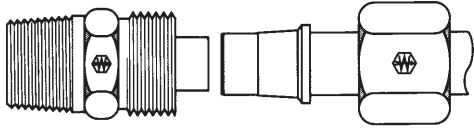

SELFALIGN® ASSEMBLY DATA CHART

Fitting Size	Annealed Copper and Soft Aluminum Tubing		Nylon Tubing			
			Type "T" Thin Wall		Type "H" Thick Wall	
	Wall	Turns*	Wall	Turns*	Wall	Turns*
2	.030	1-1/3	—	—	—	—
3	.030	1-1/3	.023	1-2/3	.039	1-1/3
4	.030	1-2/3	.030	2	.050	1-2/3
5	.032	1-2/3	.036	1-2/3	.062	2-2/3
6	.032	2	.040	1-2/3	.075	2
8	.032	2	—	—	—	—
10	.035	2	—	—	—	—
12	.049	2	—	—	—	—
16	.065	2-1/4	—	—	—	—

*Turns from "Ring Grip".

Ring Grip is the point when the cutting edge of the sleeve grips the tube. This is determined by turning tube slowly but firmly by hand while tightening the nut with a wrench until tube can no longer be turned by hand and a sharp increase in torque is noted.

NUT ASSEMBLY COMPARISON

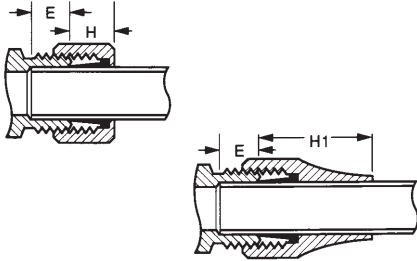

Tube O.D.	E Tube Stop Depth	H (Std. Nut)	H1 (Long Nut)
1/8	.19	.24	—
3/16	.22	.25	.49
1/4	.25	.35	.61
5/16	.28	.30	.70
3/8	.31	.31	.75
1/2	.38	.36	.83
5/8	.38	.41	.92
3/4	.44	.41	1.14

NOTE: H and H1 are hand tight dimensions.

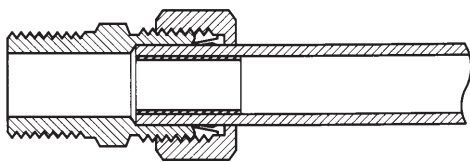

Illustration shows Selfalign® fitting used with soft plastic tubing and brass insert.

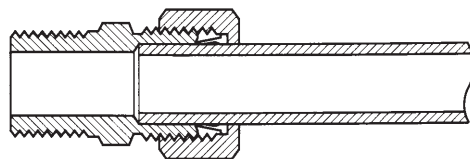
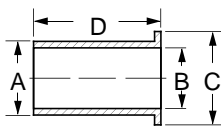
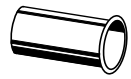

Illustration shows Selfalign® fitting used on rigid plastic tubing, no insert.

Tube Supports for Plastic Tubing



Use only with PT200 and PT240 Tubing.

* For tubing with .126 I.D./ .062 wall.

** For tubing with .170 I.D./ .040 wall.

Tube O.D.	Catalog Number	Dia. A	Dia. B	Dia. C	Length D
1/4	2030x4*	1/8	3/32	11/64	19/32
1/4	2030x44**	11/64	9/64	7/32	17/32
5/16	2030x5	3/16	5/32	15/64	5/8
3/8	2030x6	1/4	7/32	11/32	41/64
1/2	2030x8	3/8	11/32	7/16	13/16
5/8	2030x10	1/2	29/64	35/64	13/16
3/4	2030x12	9/16	33/64	11/16	1-1/32

Sleeve

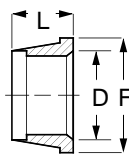

Tube O.D.	Catalog Number	D	F	L
1/8	601x2	.130	.25	.20
3/16	601x3	.193	.31	.20
1/4	601x4	.256	.38	.26
5/16	601x5	.318	.44	.26
3/8	601x6	.381	.50	.26
1/2	601x8	.507	.62	.30
5/8	601x10	.630	.72	.36
3/4	601x12	.755	.88	.38
1	601x16	1.005	1.19	.50

Nut

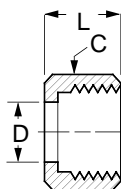
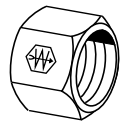

Tube O.D.	Catalog Number	Hex C	D	L
1/8	611x2	3/8	.14	.38
3/16	611x3	7/16	.19	.38
1/4	611x4	1/2	.26	.44
5/16	611x5	9/16	.32	.44
3/8	611x6	5/8	.38	.44
1/2	611x8	13/16	.51	.52
5/8	611x10	15/16	.64	.56
3/4	611x12	1-3/16	.76	.56

Long Nut

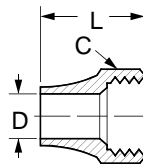
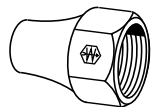

Tube O.D.	Catalog Number	Hex C	D	L
3/16	1611x3	7/16	.193	.62
1/4	1611x4	9/16	.260	.75
3/8	1611x6	11/16	.380	.88

Bulkhead Nut

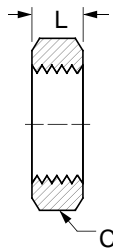

Tube O.D.	Catalog Number	Hex C	L
1/4	0102x4	9/16	.25
5/16	0102x5	5/8	.25
3/8	0102x6	11/16	.25
1/2	0102x8	15/16	.38

Use on 741x Bulkhead Unions. Ref. page 58.

Union

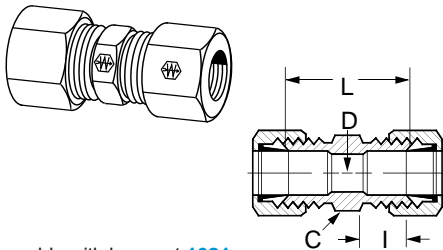

Assembly with long nut **1621x**

Tube O.D.	Catalog Number	Hex C	D	I	L
1/8	621x2	5/16	.094	.25	.66
3/16	621x3	3/8	.125	.28	.76
1/4	621x4	7/16	.188	.31	.79
5/16	621x5	1/2	.250	.34	.88
3/8	621x6	9/16	.312	.38	.97
1/2	621x8	11/16	.406	.44	1.10
5/8	621x10	13/16	.500	.50	1.25

Male Connector

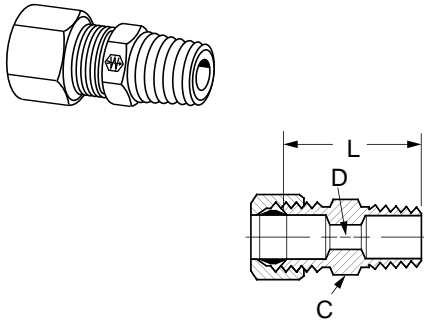

Assembly with long nut **1681x**
 *Available only as assembly with long nut.

Tube O.D.	Male Pipe Thread	Catalog Number	Hex C	D	L
1/8	1/16	681x2x1	3/8	.094	.78
1/8	1/8	681x2	7/16	.094	.78
3/16	1/8	681x3	7/16	.125	.84
1/4	1/8	681x4	7/16	.188	.88
1/4	1/4	681x4x4	9/16	.188	1.06
5/16	1/8	681x5	1/2	.234	.91
5/16	1/4	681x5x4	9/16	.250	1.09
3/8	1/8	681x6x2	9/16	.250	.97
3/8	1/4	681x6	9/16	.312	1.17
3/8	3/8	681x6x6	11/16	.312	1.16
3/8	1/2	681x6x8	7/8	.312	1.34
1/2	1/4	681x8x4	11/16	.281	1.22
1/2	3/8	681x8	11/16	.406	1.22
1/2	1/2	681x8x8	7/8	.406	1.41
5/8	1/2	681x10	7/8	.500	1.50
1	1	1681x16*	1-3/8	.875	2.00

Female Connector

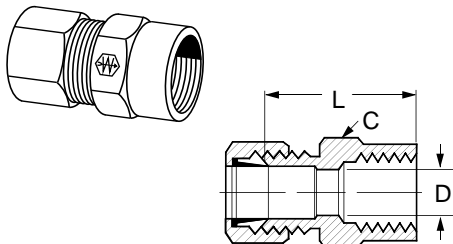

Assembly with long nut **1661x**

Tube O.D.	Fem. Pipe Thread	Catalog Number	Hex C	D	L
1/8	1/8	661x2	9/16	.094	.75
3/16	1/8	661x3	9/16	.125	.78
1/4	1/8	661x4	9/16	.188	.78
1/4	1/4	661x4x4	11/16	.188	1.03
5/16	1/8	661x5	9/16	.250	.81
3/8	1/8	661x6x2	9/16	.312	.84
3/8	1/4	661x6	11/16	.312	1.06
1/2	3/8	661x8	13/16	.406	1.12

Male Ball Check Connector

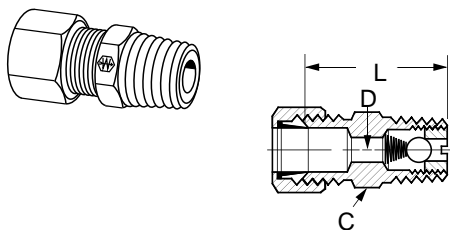

Assembly with long nut **1631x**. Min. pressure 3 psi. Ball and spring position may be reversed to change flow/check direction. Ballcheck valves are neither tested nor adjusted prior to sale.

Tube O.D.	Male Pipe Thread	Catalog Number	Hex C	D	L
1/4	1/8	631x4	7/16	.125	.88
3/8	1/4	631x6	9/16	.219	1.16

Bulkhead Union

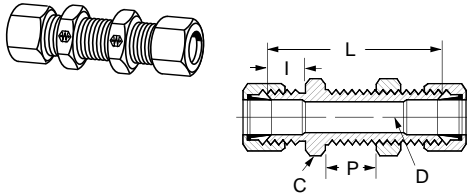

Assembly with long nut **1741x**
For Bulkhead Nuts, ref. page 56.

Tube O.D.	Catalog Number	Hex C	D	I	L	Max. P
1/4	741x4	9/16	.188	.33	1.58	.52

90° Union Elbow

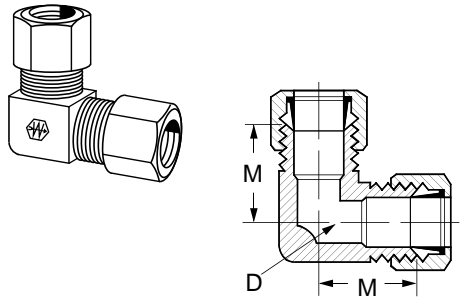

Assembly with long nut **1651x**

Tube O.D.	Catalog Number	D	M
1/4	651x4	.188	.60
3/8	651x6	.312	.73

90° Male Elbow

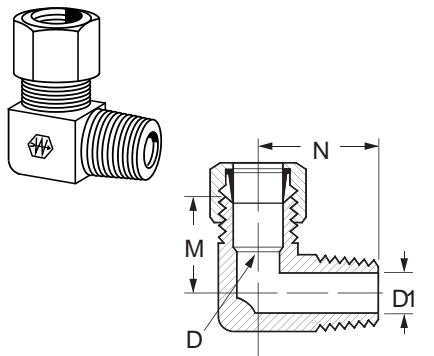

Assembly with long nut **1691x**.
*Available only as assembly with long nut.

Tube O.D.	Male Pipe Thread	Catalog Number	D	D1	M	N
1/8	1/16	691x2x1	.109	.125	.54	.66
1/8	1/8	691x2	.094	.219	.60	.67
3/16	1/8	691x3	.125	.188	.62	.69
1/4	1/8	691x4	.188	.219	.62	.75
1/4	1/4	691x4x4	.188	.219	.62	.75
5/16	1/8	691x5	.250	.250	.62	.75
5/16	1/4	691x5x4	.250	.312	.69	.84
3/8	1/8	691x6x2	.312	.234	.69	.69
3/8	1/4	691x6	.312	.344	.75	.94
3/8	3/8	691x6x6	.312	.438	.84	.94
3/8	1/2	691x6x8	.312	.531	1.06	1.12
1/2	1/4	691x8x4	.406	.312	.84	.94
1/2	3/8	691x8	.406	.406	.94	1.12
1/2	1/2	691x8x8	.406	.531	.94	1.31
5/8	1/2	691x10	.500	.562	1.06	1.31
1	1	1691x16*	.875	.938	1.31	1.62

90° Female Elbow

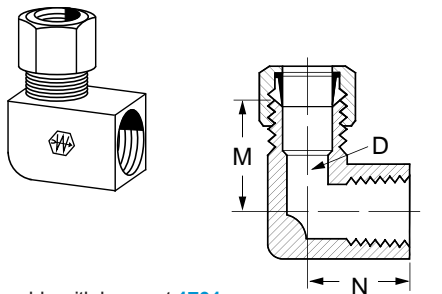

Assembly with long nut **1701x**

Tube O.D.	Fem. Pipe Thread	Catalog Number	D	M	N
3/16	1/8	701x3	.125	.69	.56
1/4	1/8	701x4	.188	.69	.56

Union Tee

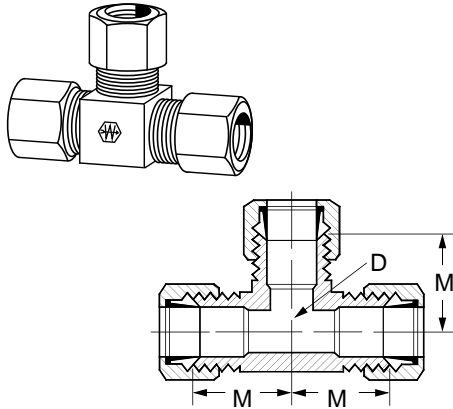

Assembly with long nut [1641x](#)

Tube O.D.	Catalog Number	D	M
3/16	641x3	.125	.60
1/4	641x4	.188	.62
5/16	641x5	.250	.60
3/8	641x6	.312	.73
1/2	641x8	.406	.94

Male Run Tee

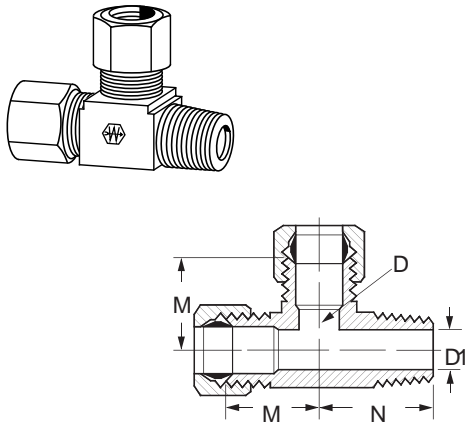

Assembly with long nut [1711x](#)

Tube O.D.	Male Pipe Thread	Catalog Number	D	D1 Opt.	M	N
3/16	1/8	711x3	.125	.219	.62	.69
1/4	1/8	711x4	.188	.219	.62	.75
3/8	1/4	711x6	.312	.344	.75	.94

Male Branch Tee

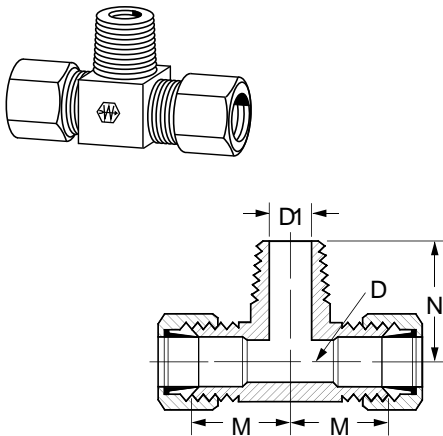

Assembly with long nut [1721x](#)

Tube O.D.	Male Pipe Thread	Catalog Number	D	D1	M	N
1/4	1/8	721x4	.188	.219	.62	.75
1/4	1/4	721x4x4x4	.188	.281	.78	.85
3/8	1/4	721x6	.312	.344	.75	.94
1/2	3/8	721x8	.406	.406	.94	1.12

⚠ Refer to safety information regarding proper selection of tubing and tube fittings on page 1.

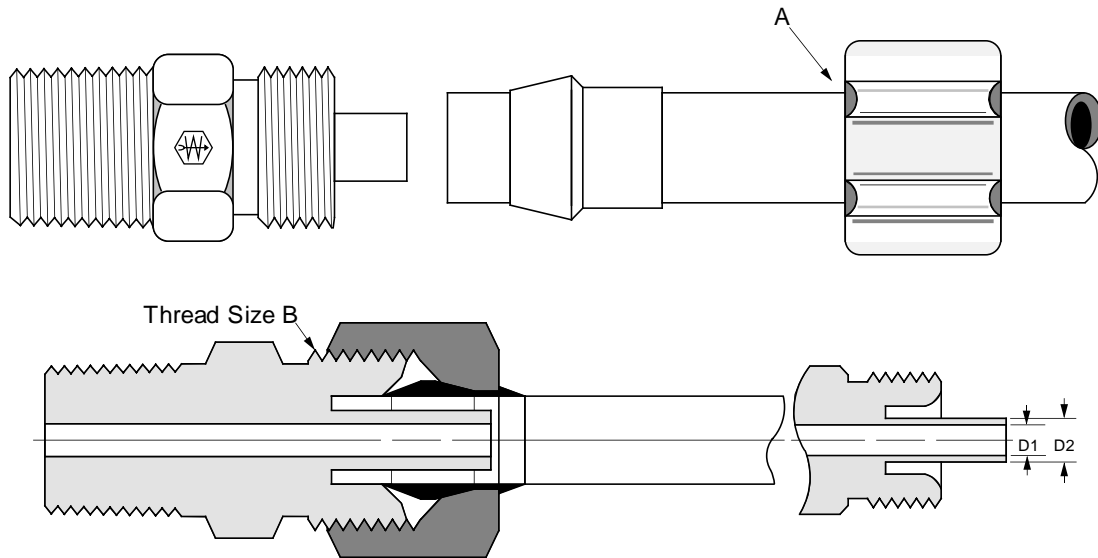

Size	x2	x3	x46	x4	x5	x6	x8
Tube O.D.	1/8	3/16	1/4	1/4	5/16	3/8	1/2
Thread Size-B	5/16-24	3/8-24	3/8-24	3/8-24	7/16-24	1/2-24	11/16-20
Flow Dia. (D1)	.094*	.125*	.078	.125	.141	.203	.312
Support Dia. (D2)	-	-	.120	.166	.180	.245	.370

*No tube support in assembly – Flow Diameter for body only.

• Typical Application

Pneumatic instrumentation circuits, lubricant and cooling lines.

• Pressure

Working pressure up to 500 psi with a 4:1 safety factor depending on tube size. When using plastic tubing, use the working pressure for type used.

• Vibration

Excellent resistance.

• Temperature Range

-65°F to +250°F (-53°C to +121°C) with brass sleeve and metal tubing. When using compatible plastic tubing do not exceed the tubing temperature range. (Refer to tubing temperature range.)

• Material

CA360 Brass body, plastic sleeve.

• Used With

Aluminum, copper and hard plastic tubing requires brass sleeve.

• Used With (Continued)

Weatherhead PT200 and PT240 plastic tubing use plastic sleeve. Not recommended for steel tubing. See page 28-32 for material compatibility and pages 33-34 for plastic tubing.

• Advantages

No flaring of tubing required. Easy installation, captive sleeve, pre-assembled for installation and can be reassembled.

• Conformance

An exclusive item with Weatherhead. User approvals only.

• How to Order

Order 1/4" O.D. tubing with .040 wall, use suffix x4. Example: 1262x4. When .062 wall is desired, use suffix x46. Example: 1262x46.

Ordered as complete assemblies (body, nuts and sleeves) by catalog number. Nuts, sleeves and nut/sleeve assemblies can be ordered separately by catalog number.

NOTE: 1/8" and 3/16" tube O.D. assemblies are supplied with brass sleeves and no inserts.

• NOTE

Refer to current price list for availability of cataloged items. Quotations and delivery of non-stock items supplied on request. Configurations and dimensions subject to change without notice.

• Assembly Instructions

1. Cut tubing to desired length.
2. Slide nut/sleeve assembly on tube. Threaded end "A" of nut must face toward fitting.
3. Bottom tubing into fitting.
4. **Plastic sleeve** - tighten nut, hand tight.
Brass sleeve - tighten nut, hand tight, then additional 3/4 turn.

Label Set: **FS-2100** (adhesive)
CL-498 (non-adhesive)

Plastic Sleeve

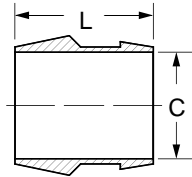
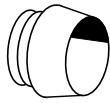

Tube O.D.	Catalog Number	C	L
1/4	1260x4	.259	.34
5/16	1260x5	.321	.39
3/8	1260x6	.384	.41
1/2	1260x8	.509	.44

Brass Sleeve

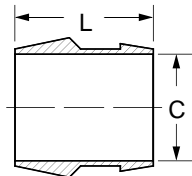

NOTE: 1/8" and 3/16" sleeve configurations vary from style illustrated

Tube O.D.	Catalog Number	C	L
1/4	1260x2B♦	.130	.34
3/16	1260x3B♦	.192	.30
1/4	1260x4B♦	.263	.31
5/16	1260x5B♦	.320	.36
3/8	1260x6B♦	.384	.38
1/2	1260x8B♦	.510	.41

Brass Nut

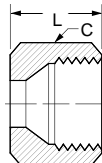
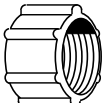

NOTE: 1/8" and 3/16" Nuts are flat Hex type

Tube O.D.	Catalog Number	Dia. C	L
1/8	1261x2	3/8	.38
3/16	1261x3	7/16	.38
1/4	1261x4	7/16	.34
5/16	1261x5♦	1/2	.34
3/8	1261x6	9/16	.38
1/2	1261x8♦	13/16	.44

Brass Nut/Plastic Sleeve Assembly

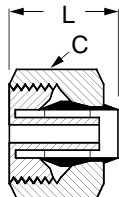
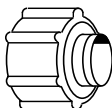

Tube O.D.	Catalog Number	Dia. C	L
1/4	1261x4A	7/16	.43
3/8	1261x6A	9/16	.49

♦MTO - Made To Order

**Brass Nut/Brass Sleeve
Assembly**

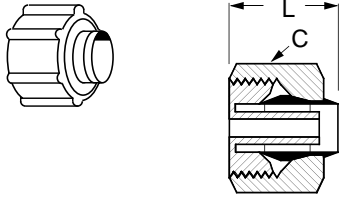

NOTE: 1/8" and 3/16" Nuts are flat Hex type

Tube O.D.	Catalog Number	Dia. C	L
1/4	1261x4B♦	9/16	.43
3/8	1261x6B♦	13/16	.49

Brass Bulkhead Nut

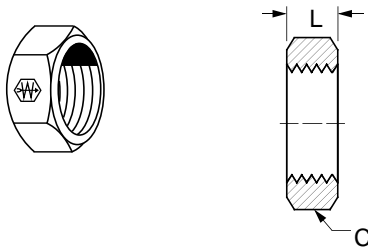

For use with 1274x Bulkhead Unions, ref. pages 63 & 64.

Tube O.D.	Catalog Number	Hex C	L
1/8	1202x2♦	5/16	.25
1/4	1202x4♦	9/16	.19
5/16	1202x5♦	5/8	.19
3/8	1202x6♦	11/16	.19
1/2	1202x8♦	7/8	.19

Union

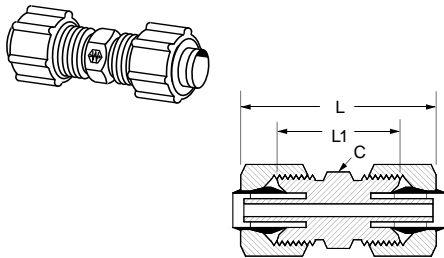

Tube O.D.	Catalog Number	Hex C	L	L1
1/8	1262x2♦	5/16	—	.66
1/4	1262x4	3/8	1.00	.69
3/8	1262x6	1/2	1.03	.72
1/2	1262x8♦	11/16	1.28	.84

Male Connector

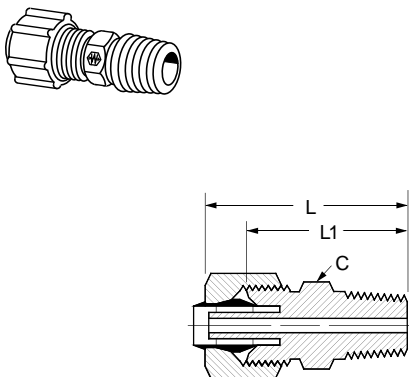

Tube O.D.	Male Pipe Thread	Catalog Number	Hex C	L	L1
1/8	1/8	1268x2♦	7/16	—	.78
3/16	1/8	1268x3♦	7/16	—	.84
1/4	1/16	1268x4x1	7/16	.97	.81
1/4	1/8	1268x4	7/16	.97	.81
1/4	1/4	1268x4x4	9/16	1.15	1.00
1/4	3/8	1268x4x6♦	11/16	1.18	1.03
5/16	1/8	1268x5♦	7/16	.97	.81
5/16	1/4	1268x5x4♦	9/16	1.16	1.00
3/8	1/8	1268x6x2	1/2	1.00	.84
3/8	1/4	1268x6	9/16	1.19	1.03
3/8	3/8	1268x6x6	11/16	1.19	1.03
1/2	1/4	1268x8x4♦	11/16	1.31	1.09
1/2	3/8	1268x8	11/16	1.31	1.09
1/2	1/2	1268x8x8♦	11/16	1.62	1.03

*10-32 Straight Thread

♦MTO - Made To Order

Female Connector

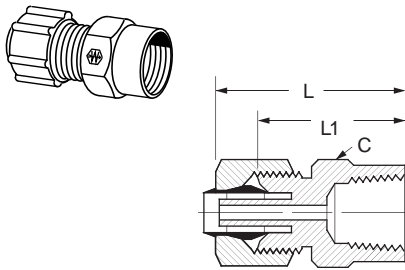

Tube O.D.	Fem. Pipe Thread	Catalog Number	Hex C	L	L1
1/8	1/8	1266x2	9/16	—	.75
1/4	1/8	1266x4	1/2	.87	.72
1/4	1/4	1266x4x4	5/8	1.09	.93
3/8	1/4	1266x6	5/8	1.09	.94

Bulkhead Union

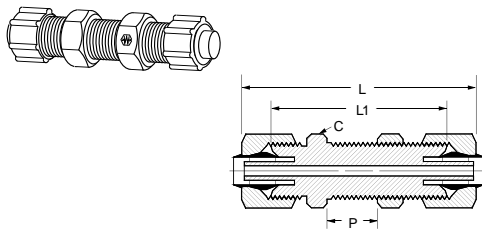

For Bulkhead Nuts, ref. page 62.

Tube O.D.	Catalog Number	Hex C	L	L1	Max. P
1/4	1274x4♦	9/16	1.56	1.25	.38
5/16	1274x5♦	5/8	1.56	1.25	.38
3/8	1274x6♦	11/16	1.68	1.38	.47
1/2	1274x8♦	7/8	2.09	1.66	.63

Male Elbow

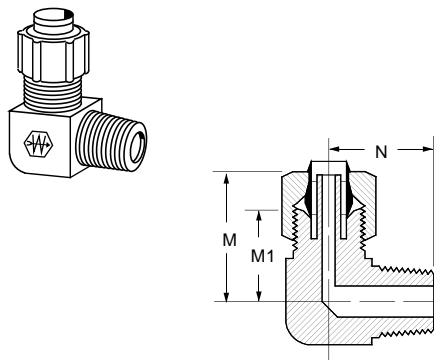

"L" Suffix designates long leg elbow

Tube O.D.	Male Pipe Thread	Catalog Number	M	M1	N
3/16	1/8	1269x3♦	—	.59	.66
1/4	1/16	1269x4x1	.75	.59	.72
1/4	1/8	1269x4	.75	.59	.72
1/4	1/4	1269x4x4	.81	.66	.94
1/4	1/4	1269x4x4L♦	.81	.66	1.38
1/4	3/8	1269x4x6	.84	.69	1.08
5/16	1/8	1269x5♦	.75	.59	.72
3/8	1/8	1269x6x2	.88	.66	.75
3/8	1/4	1269x6	.87	.72	1.00
3/8	3/8	1269x6x6	.87	.72	1.08
1/2	3/8	1269x8♦	1.06	.84	1.12

Female Elbow

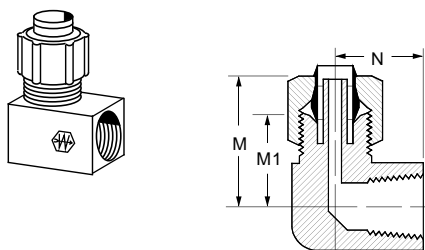

Tube O.D.	Fem. Pipe Thread	Catalog Number	M	M1	N
1/4	1/8	1270x4	.87	.66	.56
1/4	1/4	1270x4x4	.96	.75	.69
5/16	1/8	1270x5♦	.92	.66	.56
3/8	1/4	1270x6♦	.86	.75	.69
1/2	3/8	1270x8♦	1.19	.91	.94

♦MTO - Made To Order

Union Tee

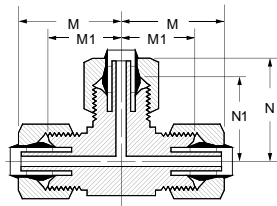
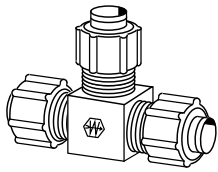

Tube O.D.	Catalog Number	M	M1	N	N1
1/4	1264x4	.75	.59	.75	.59
5/16	1264x5*	.75	.59	.75	.59
3/8x3/8x1/4	1264x6x6x4*	.88	.72	.81	.65
3/8	1264x6	.87	.72	.87	.72
1/2	1264x8*	1.06	.84	1.06	.84

Male Run Tee

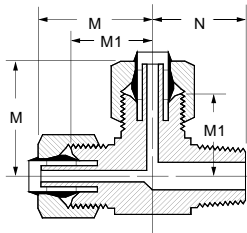
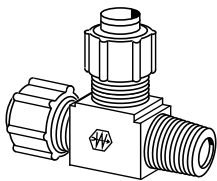

Tube O.D.	Male Pipe Thread	Catalog Number	M	M1	N
1/4	1/8	1271x4	.75	.59	.72
1/4	1/4	1271x4x4x4*	.81	.66	.94
5/16	1/8	1271x5*	.75	.59	.72
3/8	1/4	1271x6*	.87	.72	1.00
1/2	3/8	1271x8*	1.06	.84	1.12

Male Branch Tee

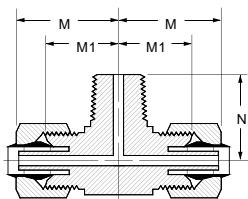
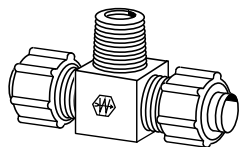

Tube O.D.	Male Pipe Thread	Catalog Number	M	M1	N
1/4	1/8	1272x4*	.75	.59	.72
1/4	1/4	1272x4x4x4*	.81	.66	.94
5/16	1/8	1272x5*	.75	.59	.72
3/8	1/4	1272x6*	.87	.72	1.00
1/2	3/8	1272x8*	1.06	.84	1.12

*MTO - Made To Order

 Refer to safety information regarding proper selection of tubing and tube fittings on page 1.

Push > Connect®

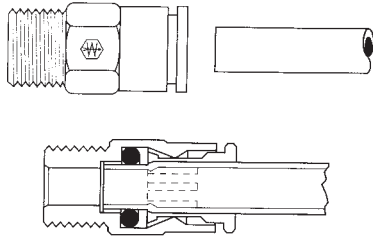

- **Typical Application:** Compressed air, pneumatic instrumentation, circuit, lubricant and cooling lines.
- **Pressure:** Up to 250 psi depending on tube size.
- **Sealing Method:** O-Ring of Buna-N Construction. (Viton available on request by special order.)
- **Temperature Range:** When using compatible plastic tubing do not exceed the tubing temperature range (Refer to tubing temperature range).
- **Material:** Brass, Nickel Plated.
- **Vacuum:** Fittings rated at 29.5 inches of mercury vacuum.
- **Used With:** PT230 and TP160 nylon, and PT240 Polyethylene tubing. See page 28-32 for material compatibility and pages 33-34 for plastic tubing.
- **Advantages:** Ease of assembly. No tools required, reusability of fittings and the time savings of assembly and disassembly.
- **Hex Dimensions:** All hexes are in inches.
- **How to Order:** Individually by catalog number.
- **NOTE:** Refer to current price list for availability of cataloged items. Quotations and delivery of non-stock items supplied on request. Configurations and dimensions subject to change without notice.
- **Assembly Instructions**
 1. To connect, simply push the tubing into the fitting.
 2. To disconnect, depress the collet ring with two fingers and withdraw.

Label Set: CL-499 (non-adhesive)

See Push > Connect®
Fittings on pages 66-70.

Push > Connect® Metric

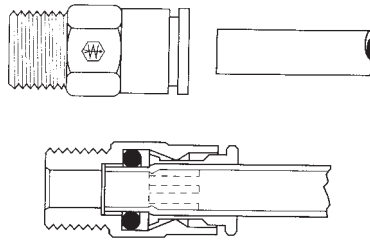

Nominal Size	2	4	5MM	6	8
Thread					
MM			M5 x .8		
BSPT	1/8 (2PT)	1/4 (4PT)		3/8 (6PT)	1/2 (8PT)
BSPP	1/8 (2PP)	1/4 (4PP)		3/8 (6PP)	1/2

- **Typical Application:** Compressed air, pneumatic instrumentation, circuit, lubricant and cooling lines.
- **Pressure:** Up to 250 psi depending on tube size.
- **Sealing Method:** O-Ring of Buna-N Construction. (Viton available on request by special order.)
- **Temperature Range:** -40°F to 200°F (-40°C to 93°C).
- **Material:** Brass, Nickel Plated.
- **Used With:** MTP160 nylon tubing. See page 28-32 for material compatibility and page 34 for plastic tubing.
- **Advantages:** Ease of assembly. No tools required, reusability of fittings and the time savings of assembly and disassembly.
- **Hex Dimensions:** All hexes are metric.
- **How to Order:** Individually by catalog number.
- **NOTE:** Refer to current price list for availability of cataloged items. Quotations and delivery of non-stock items supplied on request. Configurations and dimensions subject to change without notice.
- **Assembly Instructions**
 1. To connect, simply push the tubing into the fitting.
 2. To disconnect, depress the collet ring with two fingers and withdraw.

SUFFIX CHART

MM - Metric Screw Thread
MMS - Metric Screw Thread Swivel
MRP - Metric Red Plug
PP - British Parallel Plug
PPS - British Parallel Pipe Swivel
PT - British Tapered Pipe
PTS - British Tapered Pipe Swivel

See Push > Connect®
Fittings on pages 71-74.

Push > Connect® Flow Controls

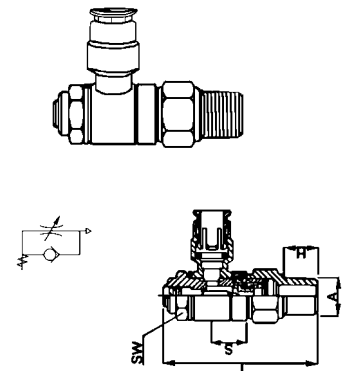

- **Typical Application:** Compressed air, pneumatic instrumentation, circuit, lubricant and cooling lines. Also excellent for assembly equipment and cylinder control.
- **Pressure:** Up to 250 psi depending on tube size.
- **Sealing Method:** O-Ring of Buna-N Construction. (Viton available on request by special order.)
- **Temperature Range:** 0°F to +160°F (-17.8°C to +71°C)
- **Material:** Brass, Nickel Plated.
- **Used With:** PT230 and TP160 nylon, and PT240 Polyethylene tubing. See page 28-32 for material compatibility and pages 33-35 for plastic tubing.
- **Advantages:** Ease of assembly. No tools required, reusability of fittings and the time savings of assembly and disassembly. These flow controls have a simple design, but offer excellent ability to control the speed of a cylinder or motor.
- **Hex Dimensions:** All hexes are in inches.
- **How to Order:** Individually by catalog number.
- **NOTE:** Refer to current price list for availability of cataloged items. Quotations and delivery of non-stock items supplied on request. Configurations and dimensions subject to change without notice.
- **Assembly Instructions**
 1. To connect, simply push the tubing into the fitting.
 2. To disconnect, depress the collet ring with two fingers and withdraw.

See Push > Connect®
Fittings on pages 75 & 76.

Cartridge

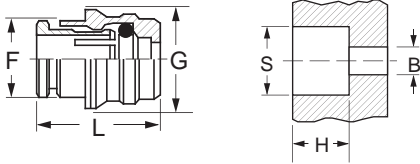

Cartridge body is not Nickel-plated.

Tube O.D.	Catalog Number	F	G	L	S	H	B
1/8	1161x2	.34	.35	.59	.344	.433	.14
5/32	1161x2.5	.34	.35	.57	.344	.433	.14
1/4	1161x4	.46	.48	.65	.470	.472	.16
5/16	1161x5	.54	.56	.67	.549	.551	.25
3/8	1161x6	.62	.64	.79	.627	.590	.32
1/2	1161x8	.74	.76	.83	.746	.629	.42

**Plug
(Plastic)**

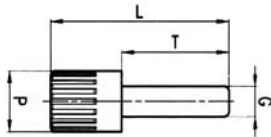

Tube O.D.	Catalog Number	L	P	T
1/8	1129x2	1.04	.24	.65
5/32	1129x2.5	1.04	.24	.65
1/4	1129x4	1.10	.32	.71
5/16	1129x5	1.20	.39	.81
3/8	1129x6	1.38	.47	.91
1/2	1129x8	1.42	.55	.94

Double Union



NOTE: Joins Push>Connect® Fittings.

Tube O.D.	Catalog Number	L
1/8	1105x2	1.28
5/32	1105x2.5	1.28
1/4	1105x4	1.40
5/16	1105x5	1.59
3/8	1105x6	1.81
1/2	1105x8	1.89

Reducer



A B

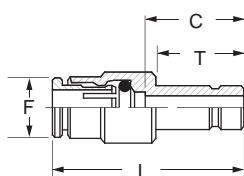

Tube O.D. A	Tube O.D. B	Catalog Number	C	F	L	T
1/8	1/4	1109x2x4	.79	.39	1.38	.71
5/32	1/4	1109x2.5x4	.79	.39	1.34	.71
1/4	3/8	1109x4x6	.86	.51	1.50	.91
1/4	1/2	1109x4x8	.86	.51	1.50	.91
3/8	1/2	1109x6x8	1.00	.67	1.80	.94

Stem Adapter

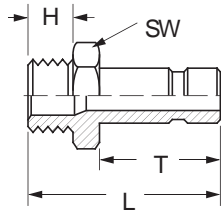

Tube O.D.	Male Pipe Thread	Catalog Number	H	T	L	SW (mm)
1/8	1/8	1180x2	.37	.65	1.20	12
1/8	1/4	1180x2x4	.51	.65	1.36	14
5/32	1/8	1180x2.5	.37	.65	1.20	12
5/32	1/4	1180x2.5x4	.51	.65	1.36	14
1/4	1/8	1180x4	.37	.71	1.26	12
1/4	1/4	1180x4x4	.51	.71	1.42	14
5/16	1/8	1180x5	.37	.81	1.36	12
5/16	1/4	1180x5x4	.51	.81	1.34	14
3/8	1/4	1180x6	.51	.91	1.61	17
3/8	3/8	1180x6x6	.51	.91	1.61	19
1/2	3/8	1180x8	.51	.94	1.65	19
1/2	1/2	1180x8x8	.71	.94	1.87	22

Union

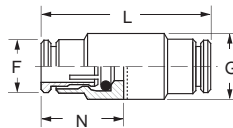

NOTE: Joins tubing.

Tube O.D.	Catalog Number	F	G	L	N
1/8	1162x2	.35	.39	1.26	.59
5/32	1162x2.5	.35	.39	1.18	.55
1/4	1162x4	.46	.47	1.40	.64
5/16	1162x5	.54	.55	1.23	.69
3/8	1162x6	.64	.67	1.67	.79
1/2	1162x8	.72	.75	1.75	.83

Bulkhead Union

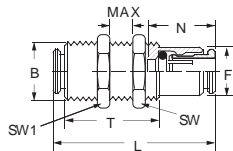

Tube O.D.	Catalog Number	B	F	L	N	MAX	SW (mm)	SW1 (mm)	T
1/8	1174x2	M10x1	.35	1.26	.59	.35	14	14	.83
5/32	1174x2.5	M10x1	.35	1.18	.55	.32	14	14	.79
1/4	1174x4	M14x1	.49	1.40	.64	.37	17	17	.83
5/16	1174x5	M16x1	.54	1.50	.69	.41	19	19	.83
3/8	1174x6	M18x1	.64	1.67	.77	.47	22	22	.93
1/2	1174x8	M20x1	.72	1.75	.83	.53	24	24	.98

Union "Y"

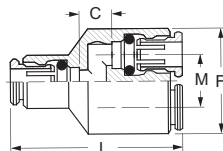

Tube O.D.	Catalog Number	C	F	L	M
1/8	1107x2	.24	.83	1.42	.39
5/32	1107x2.5	.24	.83	1.34	.39
1/4	1107x4	.24	.96	1.52	.49

NOTE: UNF thread seal with nylon washer included.

Swivel Male "Y"

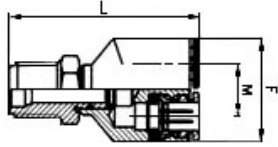

*UNF Thread

NOTE: Swivel for installation purposes only.

Tube O.D.	Male Pipe Thread	Catalog Number	F	M	L
1/8	10-32*	1108x2AS	.83	.39	1.12
1/8	1/8	1108x2S	.83	.39	1.32
5/32	1/8	1108x2.5S	.83	.39	1.29
1/4	1/8	1108x4S	.96	.49	1.40

Male Connector

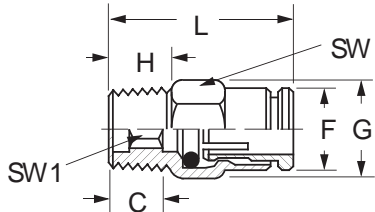

*UNF Thread

Allen wrench use permits close quarter installation not possible with a standard wrench.

Tube O.D.	Male Pipe Thread	Catalog Number	C	F	G	H	L	SW (mm)	SW1 (mm)
1/8	10-32*	1168x2A	.26	.35	.41	.18	.85	9	2
1/8	1/8	1168x2	.26	.35	.55	.37	.85	12	2
1/8	1/4	1168x2x4	.39	.35	.63	.51	.98	14	2
5/32	10-32*	1168x2.5A	.26	.35	.41	.18	.81	9	2
5/32	1/8	1168x2.5	.26	.35	.55	.37	.81	12	2.5
5/32	1/4	1168x2.5x4	.39	.35	.63	.51	.94	14	2.5
1/4	10-32*	1168x4A	.27	.46	.55	.18	.91	12	2
1/4	1/8	1168x4	.35	.46	.55	.37	.98	12	4
1/4	1/4	1168x4x4	.44	.46	.63	.51	1.08	14	4
1/4	3/8	1168x4x6	.46	.46	.87	.51	1.10	19	4
5/16	1/8	1168x5	.45	.54	.63	.37	1.14	14	5
5/16	1/4	1168x5x4	.45	.54	.63	.51	1.14	14	6
5/16	3/8	1168x5x6	.45	.54	.87	.51	1.14	19	6
3/8	1/8	1168x6x2	.59	.64	.78	.51	1.38	17	7
3/8	1/4	1168x6	.59	.64	.78	.51	1.38	17	7
3/8	3/8	1168x6x6	.39	.64	.87	.51	1.18	19	7
3/8	1/2	1168x6x8	.47	.64	1.00	.71	1.26	22	7
1/2	3/8	1168x8	.53	.72	.87	.51	1.36	19	10
1/2	1/2	1168x8x8	.53	.72	1.00	.71	1.36	22	10

Female Connector

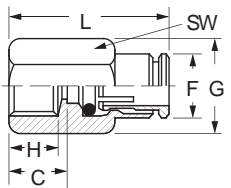
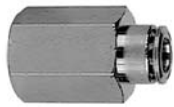

Tube O.D.	Fem. Pipe Thread	Catalog Number	C	F	G	H	L	SW (mm)
1/8	1/8	1166x2	.41	.35	.64	.34	1.00	14
1/8	1/4	1166x2x4	.55	.35	.78	.47	1.14	17
5/32	1/8	1166x2.5	.41	.35	.64	.34	.96	14
5/32	1/4	1166x2.5x4	.55	.35	.78	.47	1.10	17
1/4	1/8	1166x4	.43	.46	.64	.34	1.06	14
1/4	1/4	1166x4x4	.56	.46	.78	.47	1.20	17
3/8	1/4	1166x6	.57	.64	.78	.47	1.36	17
3/8	3/8	1166x6x6	.59	.64	1.00	.49	1.38	22

Union Elbow

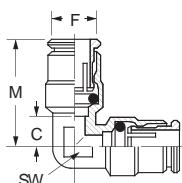

Tube O.D.	Catalog Number	C	F	M	SW (mm)
1/8	1165x2	.24	.39	.83	9
5/32	1165x2.5	.24	.39	.79	9
1/4	1165x4	.27	.50	.91	10
5/16	1165x5	.30	.59	.98	12
3/8	1165x6	.34	.69	1.12	14
1/2	1165x8	.39	.77	1.22	17

NOTE: UNF Thread seals with nylon washer, included.

Swivel Male Elbow

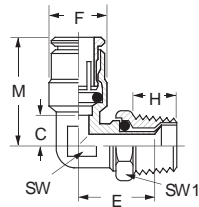

*UNF Thread

NOTE: Swivel for installation purposes only.

Tube O.D.	Male Pipe Thread	Catalog Number	C	E	F	H	M	SW (mm)	SW1 (mm)
1/8	10-32*	1169x2AS	.24	.53	.39	.18	.83	9	8
1/8	1/8	1169x2S	.24	.71	.39	.37	.83	9	12
1/8	1/4	1169x2x4S	.24	.87	.39	.51	.83	9	14
5/32	10-32*	1169x2.5AS	.24	.53	.39	.18	.79	9	8
5/32	1/8	1169x2.5S	.24	.71	.39	.37	.79	9	12
5/32	1/4	1169x2.5x4S	.24	.87	.39	.51	.83	9	14
1/4	1/8	1169x4S	.27	.73	.50	.37	.91	10	12
1/4	1/4	1169x4x4S	.27	.81	.50	.51	.91	10	14
1/4	3/8	1169x4x6S	.29	.87	.50	.51	.93	12	19
5/16	1/8	1169x5S	.30	.77	.59	.37	.98	12	12
5/16	1/4	1169x5x4S	.30	.85	.59	.51	.98	12	14
5/16	3/8	1169x5x6S	.30	.87	.59	.51	.98	12	19
3/8	1/8	1169x6x2S	.34	.75	.64	.20	1.10	14	14
3/8	1/4	1169x6S	.34	.89	.69	.51	1.12	14	14
3/8	3/8	1169x6x6S	.34	.91	.69	.51	1.12	14	19
3/8	1/2	1169x6x8S	.34	1.04	.69	.71	1.12	14	22
1/2	1/4	1169x8x4S	.39	.95	.77	.51	1.22	17	14
1/2	3/8	1169x8S	.39	.95	.77	.51	1.22	17	19
1/2	1/2	1169x8x8S	.39	1.12	.77	.71	1.22	17	22

Male Elbow

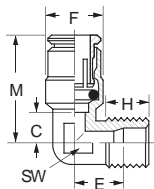

Tube O.D.	Male Pipe Thread	Catalog Number	C	E	F	H	M	SW (mm)
1/4	1/8	1169x4	.27	.53	.50	.38	.91	10
1/4	1/4	1169x4x4	.27	.59	.50	.51	.91	10
3/8	1/4	1169x6	.34	.69	.69	.51	1.12	14
3/8	3/8	1169x6x6	.34	.69	.69	.51	1.12	14

Union Tee

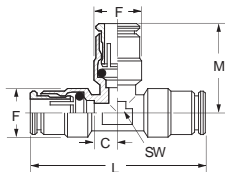

Tube O.D.	Catalog Number	C	F	L	M	SW (mm)
1/8	1164x2	.24	.39	1.65	.83	9
5/32	1164x2.5	.24	.39	1.57	.79	9
1/4	1164x4	.27	.50	1.81	.91	10
5/16	1164x5	.30	.59	1.97	.98	12
3/8	1164x6	.34	.69	2.24	1.12	14
1/2	1164x8	.39	.77	2.44	1.22	19

Male Run Tee Swivel

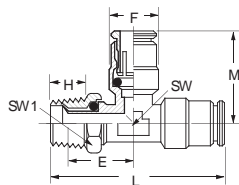

*UNF Thread

NOTE: Swivel for installation purposes only.

Tube O.D.	Male Pipe Thread	Catalog Number	E	F	H	L	M	SW (mm)	SW1 (mm)
1/8	10-32*	1171x2AS	.53	.39	.18	1.53	.83	9	8
1/8	1/8	1171x2S	.59	.35	.20	1.59	.80	9	12
5/32	10-32*	1171x2.5AS	.53	.39	.18	1.50	.79	9	8
5/32	1/8	1171x2.5S	.59	.35	.20	1.57	.79	9	12
5/32	1/4	1171x2.5x4S	.63	.35	.26	1.67	.79	9	14
1/4	1/8	1171x4S	.61	.46	.20	1.69	.89	10	12
1/4	1/4	1171x4x4S	.65	.46	.26	1.79	.89	10	14
1/4	3/8	1171x4x6S	.65	.46	.29	1.83	.89	12	19
3/8	1/4	1171x6S	.77	.64	.26	2.17	1.10	14	14
3/8	3/8	1171x6x6S	.77	.64	.29	2.26	1.10	14	19
3/8	1/2	1171x6x8S	.79	.64	.34	2.22	1.10	14	22
1/2	1/4	1171x8x4S	.81	.72	.26	2.26	1.20	17	13
1/2	3/8	1171x8S	.81	.72	.29	2.30	1.20	17	19
1/2	1/2	1171x8x8S	.83	.72	.34	2.36	1.20	17	22

NOTE: UNF Thread seals with nylon washer, included.

Male Branch Tee Swivel

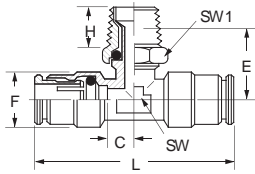

*UNF Thread

NOTE: Swivel for installation purposes only.

Tube O.D.	Male Pipe Thread	Catalog Number	C	E	F	H	L	SW (mm)	SW1 (mm)
1/8	10-32*	1172x2AS	.24	.53	.39	.18	1.61	.35	.32
1/8	1/8	1172x2S	.24	.59	.35	.20	1.57	.35	.47
5/32	10-32*	1172x2.5AS	.24	.53	.39	.18	1.57	.35	.32
5/32	1/8	1172x2.5S	.24	.59	.35	.20	1.57	.35	.47
5/32	1/4	1172x2.5x4S	.24	.63	.35	.26	1.57	.35	.55
1/4	1/8	1172x4S	.28	.60	.46	.20	1.77	.39	.47
1/4	1/4	1172x4x4S	.28	.65	.46	.26	1.77	.39	.55
1/4	3/8	1172x4x6S	.28	.65	.46	.29	1.77	.47	.75
3/8	1/4	1172x6S	.34	.77	.64	.26	2.20	.55	.55
3/8	3/8	1172x6x6S	.34	.77	.64	.29	2.20	.55	.75
3/8	1/2	1172x6x8S	.34	.79	.64	.34	2.20	.55	.87
1/2	1/4	1172x8x4S	.39	.80	.72	.26	2.40	.67	.55
1/2	3/8	1172x8S	.39	.80	.72	.29	2.40	.67	.75
1/2	1/2	1172x8x8S	.39	.83	.72	.34	2.40	.67	.87

Stud Manifolds

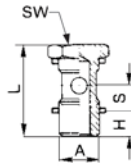

*UNF Thread

Male Pipe Thread A	Catalog Number	H	L	S (mm)	SW (mm)
10-32*	1184x1xA	.16	.71	.18	.32
1/8	1184x1x2	.24	1.06	.34	.55
1/4	1184x1x4	.35	1.16	.34	.67
3/8	1184x1x6	.35	1.18	.34	.75

Stud Manifolds

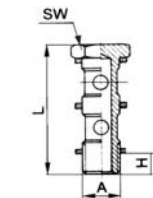

Male Pipe Thread A	Catalog Number	H	L	SW (mm)
1/8	1185x2x2	.24	1.69	.55
1/4	1185x2x4	.32	1.79	.67
3/8	1185x2x6	.32	1.81	.75

Banjo

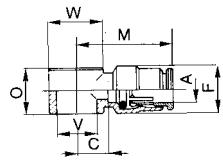

Tube O.D. A	Catalog Number	C	F	M	O	V	W
5/32	1181x2.5A	.20	.35	.75	.35	.20	.35
1/8	1181x2x2	.32	.39	.89	.57	.39	.55
5/32	1181x2.5x2	.32	.39	.89	.57	.39	.55
1/4	1181x4x2	.35	.50	.98	.57	.39	.55
1/4	1181x4x4	.43	.50	1.06	.57	.52	.71
3/8	1181x6x4	.39	.69	1.18	.57	.52	.71
3/8	1181x6x6	.45	.69	1.24	.57	.66	.83

Double Banjo

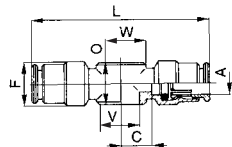

Tube O.D. A	Catalog Number	C	F	L	O	V	W
5/32	1182x2.5A	.20	.35	1.50	.35	.21	.35
1/4	1182x4x2	.32	.51	1.89	.57	.39	.55
1/4	1182x4x4	.39	.51	2.09	.57	.52	.71
3/8	1182x6x4	.39	.69	2.32	.57	.52	.71
3/8	1182x6x6	.45	.69	2.44	.57	.66	.83

Female Banjo

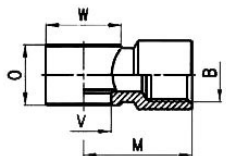

*UNF Thread

Female Pipe Thread B	Catalog Number	V	O	M	W
10-32*	1183xAxA	10-32	.35	.41	.35
1/8	1183x2x2	1/8	.57	.83	.55
1/4	1183x4x4	1/4	.57	1.02	.71
3/8	1183x6x6	3/8	.57	1.12	.83

NOTE: UNF Thread seals with nylon washer, included.

Push > Connect® Metric

Brass Fittings

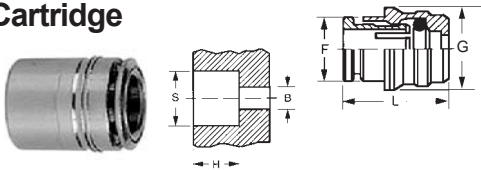
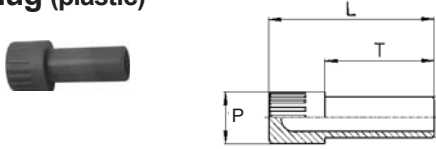
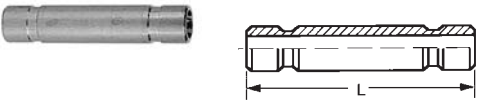
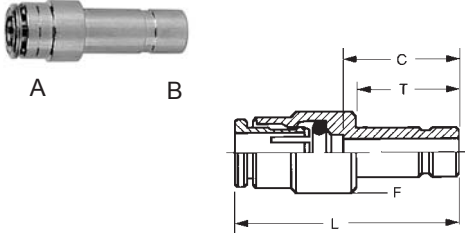
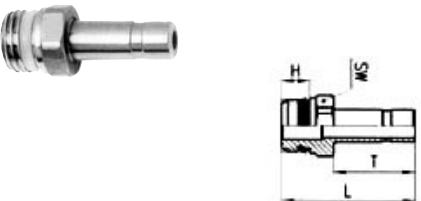
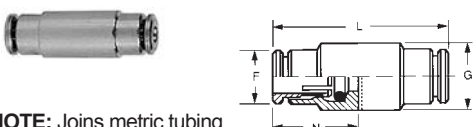
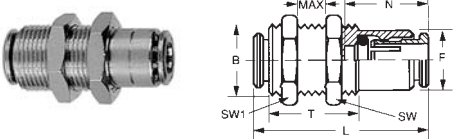
<p>Cartridge</p> 	<table border="1"> <thead> <tr> <th>Tube O.D. (mm)</th> <th>Catalog Number</th> <th>F</th> <th>G</th> <th>L</th> <th>S</th> <th>H</th> <th>B</th> </tr> </thead> <tbody> <tr><td>4</td><td>1161x4M</td><td>8.6</td><td>9.0</td><td>14.5</td><td>8.75</td><td>11.0</td><td>3.5</td></tr> <tr><td>5</td><td>1161x5M</td><td>9.6</td><td>10.0</td><td>15.5</td><td>9.75</td><td>11.5</td><td>3.5</td></tr> <tr><td>6</td><td>1161x6M</td><td>11.8</td><td>12.2</td><td>16.5</td><td>11.95</td><td>12.0</td><td>4.0</td></tr> <tr><td>8</td><td>1161x8M</td><td>13.8</td><td>14.2</td><td>18.0</td><td>13.95</td><td>14.0</td><td>6.0</td></tr> <tr><td>10</td><td>1161x10M</td><td>15.8</td><td>16.2</td><td>20.5</td><td>15.95</td><td>15.0</td><td>8.0</td></tr> </tbody> </table>	Tube O.D. (mm)	Catalog Number	F	G	L	S	H	B	4	1161x4M	8.6	9.0	14.5	8.75	11.0	3.5	5	1161x5M	9.6	10.0	15.5	9.75	11.5	3.5	6	1161x6M	11.8	12.2	16.5	11.95	12.0	4.0	8	1161x8M	13.8	14.2	18.0	13.95	14.0	6.0	10	1161x10M	15.8	16.2	20.5	15.95	15.0	8.0																																				
Tube O.D. (mm)	Catalog Number	F	G	L	S	H	B																																																																														
4	1161x4M	8.6	9.0	14.5	8.75	11.0	3.5																																																																														
5	1161x5M	9.6	10.0	15.5	9.75	11.5	3.5																																																																														
6	1161x6M	11.8	12.2	16.5	11.95	12.0	4.0																																																																														
8	1161x8M	13.8	14.2	18.0	13.95	14.0	6.0																																																																														
10	1161x10M	15.8	16.2	20.5	15.95	15.0	8.0																																																																														
<p>Plug (plastic)</p> 	<table border="1"> <thead> <tr> <th>Tube O.D. (mm)</th> <th>Catalog Number</th> <th>L</th> <th>P</th> <th>T</th> </tr> </thead> <tbody> <tr><td>4</td><td>1129x4MRP</td><td>25.0</td><td>8</td><td>16.0</td></tr> <tr><td>5</td><td>1129x5MRP</td><td>25.5</td><td>8</td><td>16.5</td></tr> <tr><td>6</td><td>1129x6MRP</td><td>26.5</td><td>8</td><td>17.5</td></tr> <tr><td>8</td><td>1129x8MRP</td><td>29.5</td><td>12</td><td>19.5</td></tr> <tr><td>10</td><td>1129x10MRP</td><td>32.0</td><td>12</td><td>19.5</td></tr> <tr><td>12</td><td>1129x12MRP</td><td>35.5</td><td>16</td><td>23.5</td></tr> </tbody> </table>	Tube O.D. (mm)	Catalog Number	L	P	T	4	1129x4MRP	25.0	8	16.0	5	1129x5MRP	25.5	8	16.5	6	1129x6MRP	26.5	8	17.5	8	1129x8MRP	29.5	12	19.5	10	1129x10MRP	32.0	12	19.5	12	1129x12MRP	35.5	16	23.5																																																	
Tube O.D. (mm)	Catalog Number	L	P	T																																																																																	
4	1129x4MRP	25.0	8	16.0																																																																																	
5	1129x5MRP	25.5	8	16.5																																																																																	
6	1129x6MRP	26.5	8	17.5																																																																																	
8	1129x8MRP	29.5	12	19.5																																																																																	
10	1129x10MRP	32.0	12	19.5																																																																																	
12	1129x12MRP	35.5	16	23.5																																																																																	
<p>Double Union</p>  <p>NOTE: Joins Metric Push>Connect® fittings.</p>	<table border="1"> <thead> <tr> <th>Tube O.D. (mm)</th> <th>Catalog Number</th> <th>L</th> </tr> </thead> <tbody> <tr><td>4</td><td>1105x4M</td><td>32.5</td></tr> <tr><td>5</td><td>1105x5M</td><td>35.0</td></tr> <tr><td>6</td><td>1105x6M</td><td>35.5</td></tr> <tr><td>8</td><td>1105x8M</td><td>40.5</td></tr> <tr><td>10</td><td>1105x10M</td><td>46.0</td></tr> <tr><td>12</td><td>1105x12M</td><td>48.0</td></tr> </tbody> </table>	Tube O.D. (mm)	Catalog Number	L	4	1105x4M	32.5	5	1105x5M	35.0	6	1105x6M	35.5	8	1105x8M	40.5	10	1105x10M	46.0	12	1105x12M	48.0																																																															
Tube O.D. (mm)	Catalog Number	L																																																																																			
4	1105x4M	32.5																																																																																			
5	1105x5M	35.0																																																																																			
6	1105x6M	35.5																																																																																			
8	1105x8M	40.5																																																																																			
10	1105x10M	46.0																																																																																			
12	1105x12M	48.0																																																																																			
<p>Reducer</p> 	<table border="1"> <thead> <tr> <th>Tube O.D. A (mm)</th> <th>Tube O.D. B (mm)</th> <th>Catalog Number</th> <th>C</th> <th>F</th> <th>L</th> <th>T</th> </tr> </thead> <tbody> <tr><td>4</td><td>5</td><td>1109x4Mx5M</td><td>20.0</td><td>10</td><td>34.0</td><td>18.0</td></tr> <tr><td>4</td><td>6</td><td>1109x4Mx6M</td><td>20.0</td><td>10</td><td>34.0</td><td>18.0</td></tr> <tr><td>4</td><td>8</td><td>1109x4Mx8M</td><td>19.0</td><td>10</td><td>33.0</td><td>20.5</td></tr> <tr><td>5</td><td>6</td><td>1109x5Mx6M</td><td>20.0</td><td>11</td><td>35.0</td><td>18.0</td></tr> <tr><td>5</td><td>8</td><td>1109x5Mx8M</td><td>19.0</td><td>11</td><td>34.0</td><td>20.5</td></tr> <tr><td>6</td><td>8</td><td>1109x6Mx8M</td><td>22.5</td><td>13</td><td>38.5</td><td>20.5</td></tr> <tr><td>6</td><td>10</td><td>1109x6Mx10M</td><td>21.0</td><td>13</td><td>36.5</td><td>23.0</td></tr> <tr><td>6</td><td>12</td><td>1109x6Mx12M</td><td>22.0</td><td>13</td><td>37.5</td><td>24.0</td></tr> <tr><td>8</td><td>10</td><td>1109x8Mx10M</td><td>25.0</td><td>14</td><td>42.5</td><td>23.0</td></tr> <tr><td>8</td><td>12</td><td>1109x8Mx12M</td><td>22.5</td><td>14</td><td>40.0</td><td>24.0</td></tr> <tr><td>10</td><td>12</td><td>1109x10Mx12M</td><td>25.5</td><td>17</td><td>45.5</td><td>24.0</td></tr> </tbody> </table>	Tube O.D. A (mm)	Tube O.D. B (mm)	Catalog Number	C	F	L	T	4	5	1109x4Mx5M	20.0	10	34.0	18.0	4	6	1109x4Mx6M	20.0	10	34.0	18.0	4	8	1109x4Mx8M	19.0	10	33.0	20.5	5	6	1109x5Mx6M	20.0	11	35.0	18.0	5	8	1109x5Mx8M	19.0	11	34.0	20.5	6	8	1109x6Mx8M	22.5	13	38.5	20.5	6	10	1109x6Mx10M	21.0	13	36.5	23.0	6	12	1109x6Mx12M	22.0	13	37.5	24.0	8	10	1109x8Mx10M	25.0	14	42.5	23.0	8	12	1109x8Mx12M	22.5	14	40.0	24.0	10	12	1109x10Mx12M	25.5	17	45.5	24.0
Tube O.D. A (mm)	Tube O.D. B (mm)	Catalog Number	C	F	L	T																																																																															
4	5	1109x4Mx5M	20.0	10	34.0	18.0																																																																															
4	6	1109x4Mx6M	20.0	10	34.0	18.0																																																																															
4	8	1109x4Mx8M	19.0	10	33.0	20.5																																																																															
5	6	1109x5Mx6M	20.0	11	35.0	18.0																																																																															
5	8	1109x5Mx8M	19.0	11	34.0	20.5																																																																															
6	8	1109x6Mx8M	22.5	13	38.5	20.5																																																																															
6	10	1109x6Mx10M	21.0	13	36.5	23.0																																																																															
6	12	1109x6Mx12M	22.0	13	37.5	24.0																																																																															
8	10	1109x8Mx10M	25.0	14	42.5	23.0																																																																															
8	12	1109x8Mx12M	22.5	14	40.0	24.0																																																																															
10	12	1109x10Mx12M	25.5	17	45.5	24.0																																																																															
<p>Stem Adapter</p> 	<table border="1"> <thead> <tr> <th>Tube O.D. (mm)</th> <th>Thd. Size BSPP D</th> <th>Catalog Number</th> <th>H</th> <th>T</th> <th>L</th> <th>SW (mm)</th> </tr> </thead> <tbody> <tr><td>4</td><td>1/8</td><td>1180x4Mx2PP</td><td>5.5</td><td>16.5</td><td>27.8</td><td>12</td></tr> <tr><td>5</td><td>1/8</td><td>1180x5Mx2PP</td><td>5.5</td><td>18.0</td><td>29.3</td><td>12</td></tr> <tr><td>6</td><td>1/8</td><td>1180x6Mx2PP</td><td>5.5</td><td>18.0</td><td>29.3</td><td>12</td></tr> <tr><td>6</td><td>1/4</td><td>1180x6Mx4PP</td><td>7.0</td><td>18.0</td><td>31.0</td><td>14</td></tr> <tr><td>8</td><td>1/8</td><td>1180x8Mx2PP</td><td>5.5</td><td>20.5</td><td>31.8</td><td>12</td></tr> <tr><td>8</td><td>1/4</td><td>1180x8Mx4PP</td><td>7.0</td><td>20.5</td><td>33.5</td><td>14</td></tr> <tr><td>10</td><td>1/4</td><td>1180x10Mx4PP</td><td>7.0</td><td>23.0</td><td>36.0</td><td>14</td></tr> <tr><td>10</td><td>3/8</td><td>1180x10Mx6PP</td><td>8.0</td><td>23.0</td><td>37.3</td><td>19</td></tr> <tr><td>12</td><td>3/8</td><td>1180x12Mx6PP</td><td>8.0</td><td>24.0</td><td>38.3</td><td>19</td></tr> </tbody> </table>	Tube O.D. (mm)	Thd. Size BSPP D	Catalog Number	H	T	L	SW (mm)	4	1/8	1180x4Mx2PP	5.5	16.5	27.8	12	5	1/8	1180x5Mx2PP	5.5	18.0	29.3	12	6	1/8	1180x6Mx2PP	5.5	18.0	29.3	12	6	1/4	1180x6Mx4PP	7.0	18.0	31.0	14	8	1/8	1180x8Mx2PP	5.5	20.5	31.8	12	8	1/4	1180x8Mx4PP	7.0	20.5	33.5	14	10	1/4	1180x10Mx4PP	7.0	23.0	36.0	14	10	3/8	1180x10Mx6PP	8.0	23.0	37.3	19	12	3/8	1180x12Mx6PP	8.0	24.0	38.3	19														
Tube O.D. (mm)	Thd. Size BSPP D	Catalog Number	H	T	L	SW (mm)																																																																															
4	1/8	1180x4Mx2PP	5.5	16.5	27.8	12																																																																															
5	1/8	1180x5Mx2PP	5.5	18.0	29.3	12																																																																															
6	1/8	1180x6Mx2PP	5.5	18.0	29.3	12																																																																															
6	1/4	1180x6Mx4PP	7.0	18.0	31.0	14																																																																															
8	1/8	1180x8Mx2PP	5.5	20.5	31.8	12																																																																															
8	1/4	1180x8Mx4PP	7.0	20.5	33.5	14																																																																															
10	1/4	1180x10Mx4PP	7.0	23.0	36.0	14																																																																															
10	3/8	1180x10Mx6PP	8.0	23.0	37.3	19																																																																															
12	3/8	1180x12Mx6PP	8.0	24.0	38.3	19																																																																															
<p>Union</p>  <p>NOTE: Joins metric tubing.</p>	<table border="1"> <thead> <tr> <th>Tube O.D. (mm)</th> <th>Catalog Number</th> <th>F</th> <th>G</th> <th>L</th> <th>N</th> </tr> </thead> <tbody> <tr><td>4</td><td>1162x4M</td><td>8.8</td><td>10</td><td>30.0</td><td>14.0</td></tr> <tr><td>5</td><td>1162x5M</td><td>9.8</td><td>11</td><td>33.0</td><td>15.0</td></tr> <tr><td>6</td><td>1162x6M</td><td>11.7</td><td>12</td><td>34.0</td><td>15.5</td></tr> <tr><td>8</td><td>1162x8M</td><td>13.7</td><td>14</td><td>38.0</td><td>17.5</td></tr> <tr><td>10</td><td>1162x10M</td><td>16.3</td><td>17</td><td>41.5</td><td>19.5</td></tr> <tr><td>12</td><td>1162x12M</td><td>18.3</td><td>19</td><td>44.5</td><td>21.0</td></tr> </tbody> </table>	Tube O.D. (mm)	Catalog Number	F	G	L	N	4	1162x4M	8.8	10	30.0	14.0	5	1162x5M	9.8	11	33.0	15.0	6	1162x6M	11.7	12	34.0	15.5	8	1162x8M	13.7	14	38.0	17.5	10	1162x10M	16.3	17	41.5	19.5	12	1162x12M	18.3	19	44.5	21.0																																										
Tube O.D. (mm)	Catalog Number	F	G	L	N																																																																																
4	1162x4M	8.8	10	30.0	14.0																																																																																
5	1162x5M	9.8	11	33.0	15.0																																																																																
6	1162x6M	11.7	12	34.0	15.5																																																																																
8	1162x8M	13.7	14	38.0	17.5																																																																																
10	1162x10M	16.3	17	41.5	19.5																																																																																
12	1162x12M	18.3	19	44.5	21.0																																																																																
<p>Bulkhead Union</p> 	<table border="1"> <thead> <tr> <th>Tube O.D. (mm)</th> <th>Catalog Number</th> <th>B</th> <th>F</th> <th>L</th> <th>N</th> <th>MAX</th> <th>SW (mm)</th> <th>SW1 (mm)</th> <th>T</th> </tr> </thead> <tbody> <tr><td>4</td><td>1174x4M</td><td>M10x1</td><td>8.6</td><td>30.0</td><td>14.0</td><td>10.5</td><td>14</td><td>14</td><td>20.0</td></tr> <tr><td>5</td><td>1174x5M</td><td>M12x1</td><td>9.8</td><td>33.0</td><td>14.5</td><td>10.5</td><td>17</td><td>17</td><td>20.0</td></tr> <tr><td>6</td><td>1174x6M</td><td>M14x1</td><td>12.5</td><td>34.0</td><td>15.5</td><td>10.5</td><td>17</td><td>17</td><td>20.0</td></tr> <tr><td>8</td><td>1174x8M</td><td>M16x1</td><td>14.5</td><td>38.0</td><td>17.5</td><td>11.5</td><td>19</td><td>19</td><td>21.0</td></tr> <tr><td>10</td><td>1174x10M</td><td>M18x1</td><td>16.3</td><td>42.5</td><td>20.0</td><td>13.0</td><td>22</td><td>22</td><td>23.5</td></tr> <tr><td>12</td><td>1174x12M</td><td>M20x1</td><td>18.3</td><td>44.5</td><td>21.0</td><td>14.5</td><td>24</td><td>24</td><td>25.0</td></tr> </tbody> </table>	Tube O.D. (mm)	Catalog Number	B	F	L	N	MAX	SW (mm)	SW1 (mm)	T	4	1174x4M	M10x1	8.6	30.0	14.0	10.5	14	14	20.0	5	1174x5M	M12x1	9.8	33.0	14.5	10.5	17	17	20.0	6	1174x6M	M14x1	12.5	34.0	15.5	10.5	17	17	20.0	8	1174x8M	M16x1	14.5	38.0	17.5	11.5	19	19	21.0	10	1174x10M	M18x1	16.3	42.5	20.0	13.0	22	22	23.5	12	1174x12M	M20x1	18.3	44.5	21.0	14.5	24	24	25.0														
Tube O.D. (mm)	Catalog Number	B	F	L	N	MAX	SW (mm)	SW1 (mm)	T																																																																												
4	1174x4M	M10x1	8.6	30.0	14.0	10.5	14	14	20.0																																																																												
5	1174x5M	M12x1	9.8	33.0	14.5	10.5	17	17	20.0																																																																												
6	1174x6M	M14x1	12.5	34.0	15.5	10.5	17	17	20.0																																																																												
8	1174x8M	M16x1	14.5	38.0	17.5	11.5	19	19	21.0																																																																												
10	1174x10M	M18x1	16.3	42.5	20.0	13.0	22	22	23.5																																																																												
12	1174x12M	M20x1	18.3	44.5	21.0	14.5	24	24	25.0																																																																												

BRASS

Union "Y"

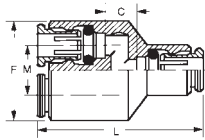

Tube O.D. (mm)	Catalog Number	F	C	L	M
4	1107x4M	18.0	6.0	33.0	10.0
6	1107x6M	24.5	7.0	39.0	12.5
8	1107x8M	29.5	9.0	44.0	14.5
10	1107x10M	33.5	15.5	53.5	16.0

Male "Y"

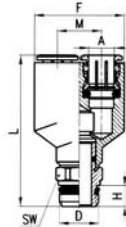

*M5 metric screw thread.

Tube O.D. (mm) A	Thread Size BSP D	Catalog Number	F	H	M	L	SW (mm)
4	1/8	1108x4Mx2PT	18.0	5.5	10.0	38.0	12
4	M5*	1108x4Mx5MM	18.0	—	10.0	27.0	N/A
6	1/8	1108x6Mx2PT	24.5	5.5	12.5	41.5	12
6	M5*	1108x6Mx5MM	24.5	—	12.5	31.0	N/A
8	1/8	1108x8Mx2PT	29.5	5.5	14.5	48.5	14
8	1/4	1108x8Mx4PT	29.5	7.0	14.5	50.0	14

Male Connector (Universal BSPT/BSPP)

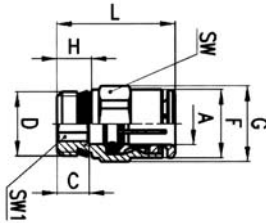

Allen wrench use permits close quarter installation not possible with a standard wrench.

Tube O.D. (mm) A	Thread Size BSP D	Catalog Number	C	F	G	H	L	SW (mm)	SW1 (mm)
4	1/8	1168x4Mx2PT	3.8	8.8	13.2	5.5	18.0	12	2.5
4	1/4	1168x4Mx4PT	6.0	8.8	15.2	7.0	19.5	14	2.5
5	1/8	1168x5Mx2PT	3.8	9.8	13.2	5.5	19.0	12	3.0
5	1/4	1168x5Mx4PT	5.5	9.8	15.2	7.0	20.0	14	3.0
6	1/8	1168x6Mx2PT	5.0	11.7	13.2	5.5	20.5	12	4.0
6	1/4	1168x6Mx4PT	5.5	11.7	15.2	7.0	21.0	14	4.0
8	1/8	1168x8Mx2PT	7.5	13.7	15.2	5.5	25.0	14	5.0
8	1/4	1168x8Mx4PT	6.5	13.7	15.2	7.0	24.0	14	6.0
8	3/8	1168x8Mx6PT	6.5	13.7	20.5	8.0	23.5	19	6.0
10	1/4	1168x10Mx4PT	8.5	16.3	18.5	7.0	28.5	17	7.0
10	3/8	1168x10Mx6PT	5.5	16.3	20.5	8.0	25.5	19	8.0
10	1/2	1168x10Mx8PT	5.0	16.3	24.5	9.0	25.0	22	8.0
12	1/4	1168x12Mx4PT	10.5	18.3	20.5	7.0	31.5	19	7.0
12	3/8	1168x12Mx6PT	9.5	18.3	20.5	8.0	30.5	19	9.0
12	1/2	1168x12Mx8PT	6.0	18.3	24.5	9.0	27.0	22	10.0

Male Connector (BSPP)

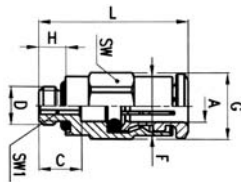

*M5 metric screw thread.

Allen wrench use permits close quarter installation not possible with a standard wrench.

Tube O.D. (mm) A	Thread Size BSP D	Catalog Number	C	F	G	H	L	SW (mm)	SW1 (mm)
4	M5*	1168x4Mx5MM	5.5	7.8	8.8	3.5	19.5	8	2
5	M5*	1168x5Mx5MM	5.5	8.8	9.9	3.5	20.5	9	2
6	M5*	1168x6Mx5MM	5.5	11.7	13.2	3.5	21.5	12	2

Female Connector (BSPP)

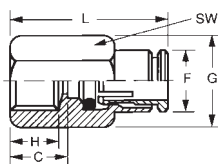

*M5 is M profile thread.

Tube O.D. (mm)	Thread Size BSP D	Catalog Number	C	F	G	H	L	SW (mm)
4	1/8	1166x4Mx2PP	9.5	9.0	15.2	7.5	23.5	14
4	M5*	1166x4Mx5MM	6.5	8.8	9.9	5.0	20.5	9
6	1/8	1166x6Mx2PP	9.5	11.7	15.2	7.5	25.5	14
6	1/4	1166x6Mx4PP	13.0	11.7	18.5	11.0	29.0	17
8	1/8	1166x8Mx2PP	10.0	13.7	15.3	7.5	27.5	14
8	1/4	1166x8Mx4PP	13.5	13.7	18.5	11.0	31.0	17
10	1/4	1166x10Mx4PP	13.5	16.3	18.5	11.0	33.0	17

NOTE: M5 has 0.8 mm thread pitch. M5 seals with nylon washer, included.

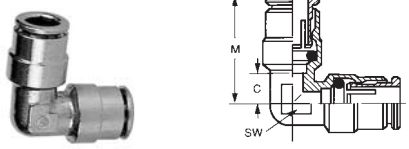
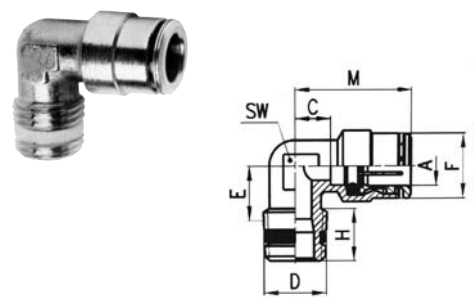
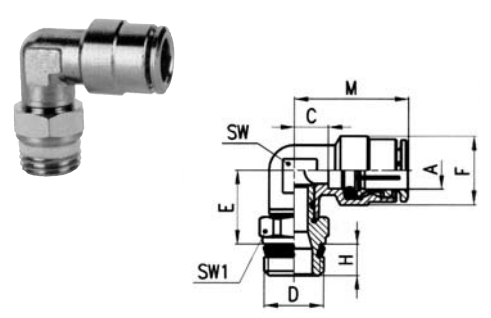
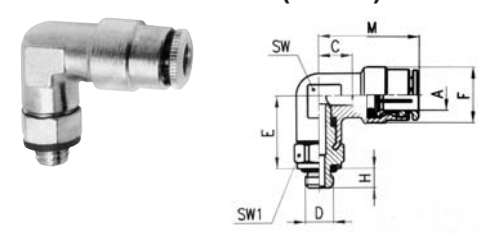
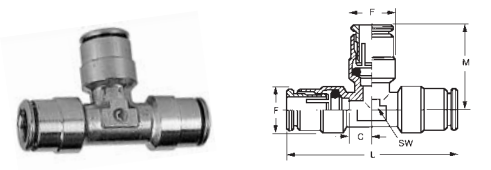
<p>Union Elbow</p> 	<table border="1"> <thead> <tr> <th>Tube O.D. (mm)</th> <th>Catalog Number</th> <th>C</th> <th>F</th> <th>M</th> <th>SW (mm)</th> </tr> </thead> <tbody> <tr><td>4</td><td>1165x4M</td><td>6.0</td><td>10.0</td><td>20</td><td>9</td></tr> <tr><td>5</td><td>1165x5M</td><td>6.0</td><td>11.0</td><td>21</td><td>9</td></tr> <tr><td>6</td><td>1165x6M</td><td>6.5</td><td>13.0</td><td>22</td><td>10</td></tr> <tr><td>8</td><td>1165x8M</td><td>7.5</td><td>15.0</td><td>25</td><td>12</td></tr> <tr><td>10</td><td>1165x10M</td><td>8.5</td><td>17.5</td><td>28</td><td>14</td></tr> <tr><td>12</td><td>1165x12M</td><td>10.0</td><td>19.5</td><td>31</td><td>16</td></tr> </tbody> </table>	Tube O.D. (mm)	Catalog Number	C	F	M	SW (mm)	4	1165x4M	6.0	10.0	20	9	5	1165x5M	6.0	11.0	21	9	6	1165x6M	6.5	13.0	22	10	8	1165x8M	7.5	15.0	25	12	10	1165x10M	8.5	17.5	28	14	12	1165x12M	10.0	19.5	31	16																																																																																																																						
Tube O.D. (mm)	Catalog Number	C	F	M	SW (mm)																																																																																																																																																												
4	1165x4M	6.0	10.0	20	9																																																																																																																																																												
5	1165x5M	6.0	11.0	21	9																																																																																																																																																												
6	1165x6M	6.5	13.0	22	10																																																																																																																																																												
8	1165x8M	7.5	15.0	25	12																																																																																																																																																												
10	1165x10M	8.5	17.5	28	14																																																																																																																																																												
12	1165x12M	10.0	19.5	31	16																																																																																																																																																												
<p>Male Elbow (BSPT)</p> 	<table border="1"> <thead> <tr> <th>Tube O.D. A (mm)</th> <th>Thread Size BSPT D</th> <th>Catalog Number</th> <th>C</th> <th>E</th> <th>F</th> <th>H</th> <th>M</th> <th>SW (mm)</th> </tr> </thead> <tbody> <tr><td>4</td><td>1/8</td><td>1169x4Mx2PT</td><td>6.0</td><td>14.5</td><td>10.0</td><td>7.5</td><td>20</td><td>9</td></tr> <tr><td>4</td><td>1/4</td><td>1169x4Mx4PT</td><td>6.0</td><td>14.5</td><td>10.0</td><td>11.0</td><td>20</td><td>9</td></tr> <tr><td>5</td><td>1/8</td><td>1169x5Mx2PT</td><td>6.0</td><td>14.5</td><td>11.0</td><td>7.5</td><td>21</td><td>9</td></tr> <tr><td>5</td><td>1/4</td><td>1169x5Mx4PT</td><td>6.0</td><td>14.5</td><td>11.0</td><td>11.0</td><td>21</td><td>9</td></tr> <tr><td>6</td><td>1/8</td><td>1169x6Mx2PT</td><td>6.5</td><td>15.0</td><td>12.7</td><td>8.5</td><td>22</td><td>10</td></tr> <tr><td>6</td><td>1/4</td><td>1169x6Mx4PT</td><td>6.5</td><td>15.0</td><td>12.7</td><td>11.5</td><td>22</td><td>10</td></tr> <tr><td>8</td><td>1/8</td><td>1169x8Mx2PT</td><td>7.5</td><td>16.0</td><td>15.0</td><td>8.5</td><td>25</td><td>12</td></tr> <tr><td>8</td><td>1/4</td><td>1169x8Mx4PT</td><td>7.5</td><td>16.0</td><td>15.0</td><td>11.0</td><td>25</td><td>12</td></tr> <tr><td>8</td><td>3/8</td><td>1169x8Mx6PT</td><td>7.5</td><td>16.3</td><td>15.0</td><td>11.5</td><td>25</td><td>12</td></tr> <tr><td>10</td><td>1/4</td><td>1169x10Mx4PT</td><td>7.5</td><td>18.5</td><td>17.5</td><td>11.5</td><td>27</td><td>14</td></tr> <tr><td>10</td><td>3/8</td><td>1169x10Mx6PT</td><td>7.5</td><td>19.0</td><td>17.5</td><td>11.5</td><td>27</td><td>14</td></tr> <tr><td>12</td><td>1/4</td><td>1169x12Mx4PT</td><td>10.0</td><td>20.0</td><td>19.5</td><td>11.5</td><td>31</td><td>16</td></tr> <tr><td>12</td><td>3/8</td><td>1169x12Mx6PT</td><td>10.0</td><td>20.0</td><td>19.5</td><td>11.5</td><td>31</td><td>16</td></tr> </tbody> </table>	Tube O.D. A (mm)	Thread Size BSPT D	Catalog Number	C	E	F	H	M	SW (mm)	4	1/8	1169x4Mx2PT	6.0	14.5	10.0	7.5	20	9	4	1/4	1169x4Mx4PT	6.0	14.5	10.0	11.0	20	9	5	1/8	1169x5Mx2PT	6.0	14.5	11.0	7.5	21	9	5	1/4	1169x5Mx4PT	6.0	14.5	11.0	11.0	21	9	6	1/8	1169x6Mx2PT	6.5	15.0	12.7	8.5	22	10	6	1/4	1169x6Mx4PT	6.5	15.0	12.7	11.5	22	10	8	1/8	1169x8Mx2PT	7.5	16.0	15.0	8.5	25	12	8	1/4	1169x8Mx4PT	7.5	16.0	15.0	11.0	25	12	8	3/8	1169x8Mx6PT	7.5	16.3	15.0	11.5	25	12	10	1/4	1169x10Mx4PT	7.5	18.5	17.5	11.5	27	14	10	3/8	1169x10Mx6PT	7.5	19.0	17.5	11.5	27	14	12	1/4	1169x12Mx4PT	10.0	20.0	19.5	11.5	31	16	12	3/8	1169x12Mx6PT	10.0	20.0	19.5	11.5	31	16																																		
Tube O.D. A (mm)	Thread Size BSPT D	Catalog Number	C	E	F	H	M	SW (mm)																																																																																																																																																									
4	1/8	1169x4Mx2PT	6.0	14.5	10.0	7.5	20	9																																																																																																																																																									
4	1/4	1169x4Mx4PT	6.0	14.5	10.0	11.0	20	9																																																																																																																																																									
5	1/8	1169x5Mx2PT	6.0	14.5	11.0	7.5	21	9																																																																																																																																																									
5	1/4	1169x5Mx4PT	6.0	14.5	11.0	11.0	21	9																																																																																																																																																									
6	1/8	1169x6Mx2PT	6.5	15.0	12.7	8.5	22	10																																																																																																																																																									
6	1/4	1169x6Mx4PT	6.5	15.0	12.7	11.5	22	10																																																																																																																																																									
8	1/8	1169x8Mx2PT	7.5	16.0	15.0	8.5	25	12																																																																																																																																																									
8	1/4	1169x8Mx4PT	7.5	16.0	15.0	11.0	25	12																																																																																																																																																									
8	3/8	1169x8Mx6PT	7.5	16.3	15.0	11.5	25	12																																																																																																																																																									
10	1/4	1169x10Mx4PT	7.5	18.5	17.5	11.5	27	14																																																																																																																																																									
10	3/8	1169x10Mx6PT	7.5	19.0	17.5	11.5	27	14																																																																																																																																																									
12	1/4	1169x12Mx4PT	10.0	20.0	19.5	11.5	31	16																																																																																																																																																									
12	3/8	1169x12Mx6PT	10.0	20.0	19.5	11.5	31	16																																																																																																																																																									
<p>Male Elbow Swivel (Universal BSPT/BSPP)</p>  <p>NOTE: Swivel for installation purposes only.</p>	<table border="1"> <thead> <tr> <th>Tube O.D. A (mm)</th> <th>Thread Size BSPT D</th> <th>Catalog Number</th> <th>C</th> <th>E</th> <th>F</th> <th>H</th> <th>M</th> <th>SW (mm)</th> <th>SW1 (mm)</th> </tr> </thead> <tbody> <tr><td>4</td><td>1/8</td><td>1169x4Mx2PTS</td><td>6.0</td><td>14.5</td><td>10.0</td><td>5.5</td><td>20.0</td><td>9</td><td>12</td></tr> <tr><td>4</td><td>1/4</td><td>1169x4Mx4PTS</td><td>6.0</td><td>14.5</td><td>10.0</td><td>7.0</td><td>20.0</td><td>9</td><td>14</td></tr> <tr><td>5</td><td>1/8</td><td>1169x5Mx2PTS</td><td>6.0</td><td>14.5</td><td>11.0</td><td>5.5</td><td>21.0</td><td>9</td><td>12</td></tr> <tr><td>5</td><td>1/4</td><td>1169x5Mx4PTS</td><td>6.0</td><td>14.5</td><td>11.0</td><td>7.0</td><td>21.0</td><td>9</td><td>14</td></tr> <tr><td>6</td><td>1/8</td><td>1169x6Mx2PTS</td><td>6.5</td><td>15.0</td><td>12.7</td><td>5.5</td><td>22.0</td><td>10</td><td>12</td></tr> <tr><td>6</td><td>1/4</td><td>1169x6Mx4PTS</td><td>6.5</td><td>15.0</td><td>12.7</td><td>7.0</td><td>22.5</td><td>10</td><td>14</td></tr> <tr><td>8</td><td>1/8</td><td>1169x8Mx2PTS</td><td>7.5</td><td>16.0</td><td>15.0</td><td>5.5</td><td>25.5</td><td>12</td><td>12</td></tr> <tr><td>8</td><td>1/4</td><td>1169x8Mx4PTS</td><td>7.5</td><td>16.0</td><td>15.0</td><td>7.0</td><td>25.0</td><td>12</td><td>14</td></tr> <tr><td>8</td><td>3/8</td><td>1169x8Mx6PTS</td><td>7.5</td><td>16.5</td><td>15.0</td><td>8.0</td><td>25.0</td><td>12</td><td>19</td></tr> <tr><td>10</td><td>1/4</td><td>1169x10Mx4PTS</td><td>8.5</td><td>18.5</td><td>17.5</td><td>7.0</td><td>28.5</td><td>14</td><td>14</td></tr> <tr><td>10</td><td>3/8</td><td>1169x10Mx6PTS</td><td>8.5</td><td>19.0</td><td>17.5</td><td>8.0</td><td>28.5</td><td>14</td><td>19</td></tr> <tr><td>10</td><td>1/2</td><td>1169x10Mx8PTS</td><td>8.5</td><td>19.5</td><td>17.5</td><td>9.0</td><td>28.5</td><td>14</td><td>22</td></tr> <tr><td>12</td><td>1/4</td><td>1169x12Mx4PTS</td><td>10.0</td><td>20.0</td><td>19.5</td><td>7.0</td><td>31.0</td><td>16</td><td>17</td></tr> <tr><td>12</td><td>3/8</td><td>1169x12Mx6PTS</td><td>10.0</td><td>20.0</td><td>19.5</td><td>8.0</td><td>31.0</td><td>16</td><td>19</td></tr> <tr><td>12</td><td>1/2</td><td>1169x12Mx8PTS</td><td>10.0</td><td>20.5</td><td>19.5</td><td>9.0</td><td>31.0</td><td>16</td><td>22</td></tr> </tbody> </table>	Tube O.D. A (mm)	Thread Size BSPT D	Catalog Number	C	E	F	H	M	SW (mm)	SW1 (mm)	4	1/8	1169x4Mx2PTS	6.0	14.5	10.0	5.5	20.0	9	12	4	1/4	1169x4Mx4PTS	6.0	14.5	10.0	7.0	20.0	9	14	5	1/8	1169x5Mx2PTS	6.0	14.5	11.0	5.5	21.0	9	12	5	1/4	1169x5Mx4PTS	6.0	14.5	11.0	7.0	21.0	9	14	6	1/8	1169x6Mx2PTS	6.5	15.0	12.7	5.5	22.0	10	12	6	1/4	1169x6Mx4PTS	6.5	15.0	12.7	7.0	22.5	10	14	8	1/8	1169x8Mx2PTS	7.5	16.0	15.0	5.5	25.5	12	12	8	1/4	1169x8Mx4PTS	7.5	16.0	15.0	7.0	25.0	12	14	8	3/8	1169x8Mx6PTS	7.5	16.5	15.0	8.0	25.0	12	19	10	1/4	1169x10Mx4PTS	8.5	18.5	17.5	7.0	28.5	14	14	10	3/8	1169x10Mx6PTS	8.5	19.0	17.5	8.0	28.5	14	19	10	1/2	1169x10Mx8PTS	8.5	19.5	17.5	9.0	28.5	14	22	12	1/4	1169x12Mx4PTS	10.0	20.0	19.5	7.0	31.0	16	17	12	3/8	1169x12Mx6PTS	10.0	20.0	19.5	8.0	31.0	16	19	12	1/2	1169x12Mx8PTS	10.0	20.5	19.5	9.0	31.0	16	22
Tube O.D. A (mm)	Thread Size BSPT D	Catalog Number	C	E	F	H	M	SW (mm)	SW1 (mm)																																																																																																																																																								
4	1/8	1169x4Mx2PTS	6.0	14.5	10.0	5.5	20.0	9	12																																																																																																																																																								
4	1/4	1169x4Mx4PTS	6.0	14.5	10.0	7.0	20.0	9	14																																																																																																																																																								
5	1/8	1169x5Mx2PTS	6.0	14.5	11.0	5.5	21.0	9	12																																																																																																																																																								
5	1/4	1169x5Mx4PTS	6.0	14.5	11.0	7.0	21.0	9	14																																																																																																																																																								
6	1/8	1169x6Mx2PTS	6.5	15.0	12.7	5.5	22.0	10	12																																																																																																																																																								
6	1/4	1169x6Mx4PTS	6.5	15.0	12.7	7.0	22.5	10	14																																																																																																																																																								
8	1/8	1169x8Mx2PTS	7.5	16.0	15.0	5.5	25.5	12	12																																																																																																																																																								
8	1/4	1169x8Mx4PTS	7.5	16.0	15.0	7.0	25.0	12	14																																																																																																																																																								
8	3/8	1169x8Mx6PTS	7.5	16.5	15.0	8.0	25.0	12	19																																																																																																																																																								
10	1/4	1169x10Mx4PTS	8.5	18.5	17.5	7.0	28.5	14	14																																																																																																																																																								
10	3/8	1169x10Mx6PTS	8.5	19.0	17.5	8.0	28.5	14	19																																																																																																																																																								
10	1/2	1169x10Mx8PTS	8.5	19.5	17.5	9.0	28.5	14	22																																																																																																																																																								
12	1/4	1169x12Mx4PTS	10.0	20.0	19.5	7.0	31.0	16	17																																																																																																																																																								
12	3/8	1169x12Mx6PTS	10.0	20.0	19.5	8.0	31.0	16	19																																																																																																																																																								
12	1/2	1169x12Mx8PTS	10.0	20.5	19.5	9.0	31.0	16	22																																																																																																																																																								
<p>Male Elbow Swivel (BSPP)</p>  <p>NOTE: Swivel for installation purposes only. *M5 metric screw thread.</p>	<table border="1"> <thead> <tr> <th>Tube O.D. A (mm)</th> <th>Thread Size BSPP D</th> <th>Catalog Number</th> <th>C</th> <th>E</th> <th>F</th> <th>H</th> <th>M</th> <th>SW (mm)</th> <th>SW1 (mm)</th> </tr> </thead> <tbody> <tr><td>4</td><td>M5*</td><td>1169x4Mx5MMS</td><td>6</td><td>13</td><td>10</td><td>3.5</td><td>20</td><td>9</td><td>8</td></tr> <tr><td>5</td><td>M5*</td><td>1169x5Mx5MMS</td><td>6</td><td>13</td><td>11</td><td>3.5</td><td>21</td><td>9</td><td>8</td></tr> </tbody> </table>	Tube O.D. A (mm)	Thread Size BSPP D	Catalog Number	C	E	F	H	M	SW (mm)	SW1 (mm)	4	M5*	1169x4Mx5MMS	6	13	10	3.5	20	9	8	5	M5*	1169x5Mx5MMS	6	13	11	3.5	21	9	8																																																																																																																																		
Tube O.D. A (mm)	Thread Size BSPP D	Catalog Number	C	E	F	H	M	SW (mm)	SW1 (mm)																																																																																																																																																								
4	M5*	1169x4Mx5MMS	6	13	10	3.5	20	9	8																																																																																																																																																								
5	M5*	1169x5Mx5MMS	6	13	11	3.5	21	9	8																																																																																																																																																								
<p>Union Tee</p> 	<table border="1"> <thead> <tr> <th>Tube O.D. (mm)</th> <th>Catalog Number</th> <th>C</th> <th>F</th> <th>L</th> <th>M</th> <th>SW (mm)</th> </tr> </thead> <tbody> <tr><td>4</td><td>1164x4M</td><td>6.0</td><td>10.0</td><td>40</td><td>20.0</td><td>9</td></tr> <tr><td>5</td><td>1164x5M</td><td>6.0</td><td>11.0</td><td>42</td><td>21.0</td><td>9</td></tr> <tr><td>6</td><td>1164x6M</td><td>6.5</td><td>12.7</td><td>45</td><td>22.5</td><td>10</td></tr> <tr><td>8</td><td>1164x8M</td><td>7.5</td><td>15.0</td><td>50</td><td>25.0</td><td>12</td></tr> <tr><td>10</td><td>1164x10M</td><td>8.5</td><td>17.5</td><td>57</td><td>28.5</td><td>14</td></tr> <tr><td>12</td><td>1164x12M</td><td>10.0</td><td>19.5</td><td>62</td><td>31.0</td><td>16</td></tr> </tbody> </table>	Tube O.D. (mm)	Catalog Number	C	F	L	M	SW (mm)	4	1164x4M	6.0	10.0	40	20.0	9	5	1164x5M	6.0	11.0	42	21.0	9	6	1164x6M	6.5	12.7	45	22.5	10	8	1164x8M	7.5	15.0	50	25.0	12	10	1164x10M	8.5	17.5	57	28.5	14	12	1164x12M	10.0	19.5	62	31.0	16																																																																																																															
Tube O.D. (mm)	Catalog Number	C	F	L	M	SW (mm)																																																																																																																																																											
4	1164x4M	6.0	10.0	40	20.0	9																																																																																																																																																											
5	1164x5M	6.0	11.0	42	21.0	9																																																																																																																																																											
6	1164x6M	6.5	12.7	45	22.5	10																																																																																																																																																											
8	1164x8M	7.5	15.0	50	25.0	12																																																																																																																																																											
10	1164x10M	8.5	17.5	57	28.5	14																																																																																																																																																											
12	1164x12M	10.0	19.5	62	31.0	16																																																																																																																																																											

NOTE: M5 has 0.8 mm thread pitch. M5 seals with nylon washer, included.

Male Run Tee Swivel (Universal BSPT/BSPP)

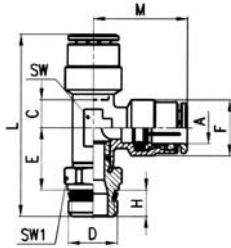

NOTE: Swivel for installation purposes only.

Tube O.D. A (mm)	Thread Size BSP D	Catalog Number	C	E	F	H	L	M	SW	SW1 (mm)
4	1/8	1171x4Mx2PTS	6.0	14.5	10.0	5.5	40.0	20.0	9	12
5	1/8	1171x5Mx2PTS	6.0	14.5	11.0	5.5	41.0	21.0	9	12
5	1/4	1171x5Mx4PTS	6.0	14.5	11.0	7.0	42.5	21.0	9	14
6	1/8	1171x6Mx2PTS	6.5	15.0	12.7	5.5	42.5	22.5	10	12
6	1/4	1171x6Mx4PTS	6.5	15.0	12.7	7.0	44.0	22.5	10	14
8	1/8	1171x8Mx2PTS	7.5	16.0	15.0	5.5	46.5	25.0	12	12
8	1/4	1171x8Mx4PTS	7.5	16.0	15.0	7.0	48.0	25.0	12	14
8	3/8	1171x8Mx6PTS	7.5	16.5	15.0	8.0	49.5	25.0	12	19
10	1/4	1171x10Mx4PTS	8.5	18.5	17.5	7.0	54.0	28.5	14	14
10	3/8	1171x10Mx6PTS	8.5	18.5	17.5	8.0	55.5	28.5	14	19
12	3/8	1171x12Mx6PTS	10.0	19.5	19.5	8.0	59.0	31.0	16	19

Male Run Tee Swivel (BSPP)

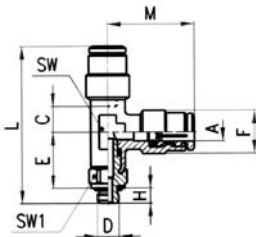

NOTE: Swivel for installation purposes only.
*M5 metric screw thread

Tube O.D. A (mm)	Thread Size BSPP D	Catalog Number	C	E	F	H	L	M	SW	SW1 (mm)
4	M5*	1171x4Mx5MMS	6	13	10	3.5	36.5	20	9	8
5	M5*	1171x5Mx5MMS	6	13	11	3.5	37.5	21	9	8

Male Branch Tee Swivel (BSPT)

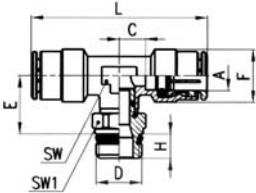

NOTE: Swivel for installation purposes only.

Tube O.D. A (mm)	Thread Size BSP D	Catalog Number	C	E	F	H	L	SW	SW1 (mm)
4	1/8	1172x4Mx2PTS	6.0	14.5	10.0	5.5	40	9	12
5	1/8	1172x5Mx2PTS	6.0	14.5	11.0	5.5	42	9	12
5	1/4	1172x5Mx4PTS	6.0	14.5	11.0	7.0	42	9	14
6	1/8	1172x6Mx2PTS	6.5	15.0	12.7	5.5	44	10	12
6	1/4	1172x6Mx4PTS	6.5	15.0	12.7	7.0	44	10	14
8	1/8	1172x8Mx2PTS	7.5	16.0	15.0	5.5	50	12	12
8	1/4	1172x8Mx4PTS	7.5	16.0	15.0	7.0	50	12	14
8	3/8	1172x8Mx6PTS	7.5	16.5	15.0	8.0	50	12	19
10	1/4	1172x10Mx4PTS	8.5	18.5	17.5	7.0	57	14	14
10	3/8	1172x10Mx6PTS	8.5	19.0	17.5	8.0	57	14	19
12	1/4	1172x12Mx4PTS	10.0	20.0	19.5	7.0	62	16	17
12	3/8	1172x12Mx6PTS	10.0	20.0	19.5	8.0	62	16	19
12	1/2	1172x12Mx8PTS	10.0	20.5	19.5	9.0	62	16	22

Male Branch Tee Swivel (BSPP)

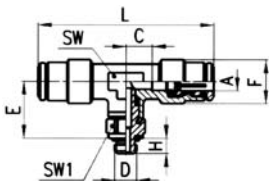

NOTE: Swivel for installation purposes only.
*M5 metric screw thread

Tube O.D. A (mm)	Thread Size BSPP D	Catalog Number	C	E	F	H	L	SW	SW1 (mm)
4	M5*	1172x4Mx5MMS	6	13	10	3.5	40	9	8
5	M5*	1172x5Mx5MMS	6	13	11	3.5	42	9	8

NOTE: M5 has 0.8 mm thread pitch. M5 seals with nylon washer, included.

RIGHT ANGLE FLOW CONTROL AND NEEDLE VALVES

SCU-MCU

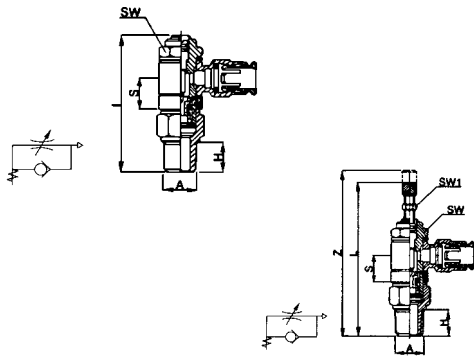

Technical Data

Valve:	Flow Regulator
Regulation:	Adjustable Screw
Material:	Brass; Nickel Plated
Seals:	Buna-N
Threads:	10-32UNF-1/8-1/4-3/8NPTF
Tube Sizes:	1/8 - 5/32 - 1/4 - 3/8
Operating Pressures:	to 150 PSI
Nominal Diameter:	10-32 UNF = .059 - 1/8 = .078 1/4 = .157 - 3/8 = .275

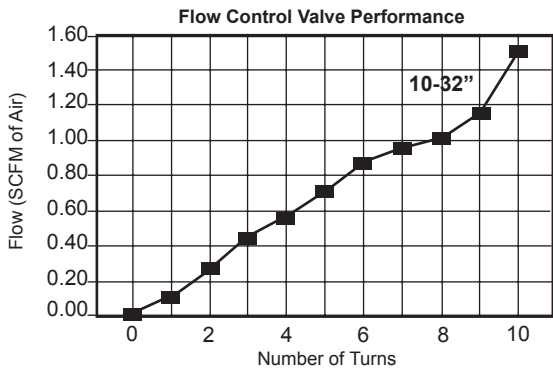

Air flow (SCFM) from B to A
With adjustment open 1.9
With adjustment closed 1.4

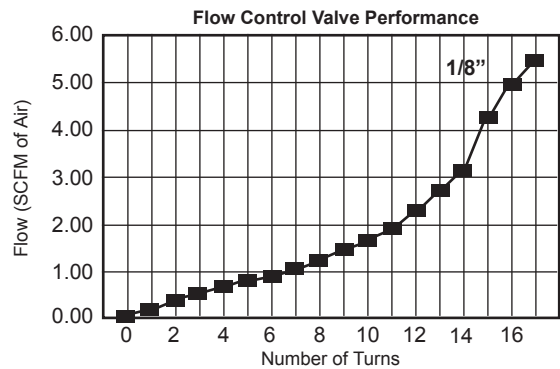

Air flow (SCFM) from B to A
With adjustment open 5.7
With adjustment closed 3.6

Air flow is determined with 85 PSI at the in port and with 70 PSI at the outlet

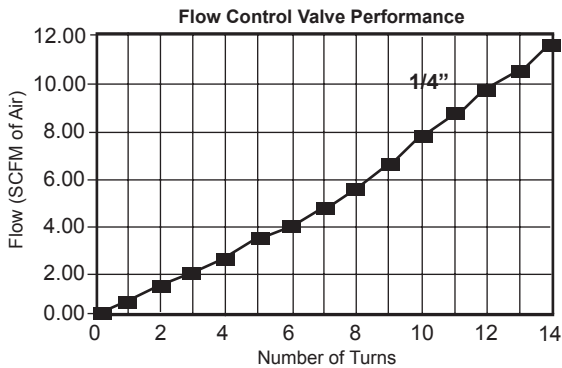

Air flow (SCFM) from B to A
With adjustment open 15
With adjustment closed 8

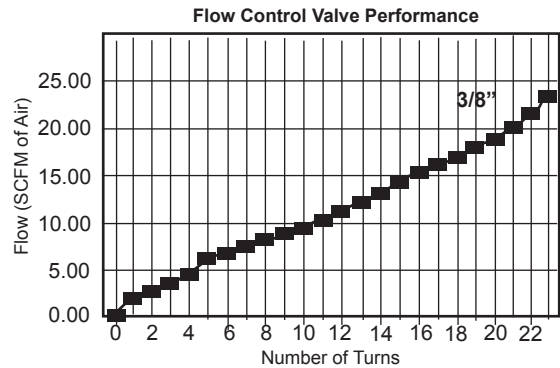

Air flow (SCFM) from B to A
With adjustment open 23
With adjustment closed 13

Air flow is determined with 85 PSI at the in port and with 70 PSI at the outlet

NOTE: We reserve the right to alter these specifications without prior notice.

BRASS

These unidirectional flow controllers have been designed as small as possible so as to be mounted directly on valves or cylinders.

Identification of flow control

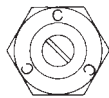

SCU
MCU

Coding of Banjo flow controllers

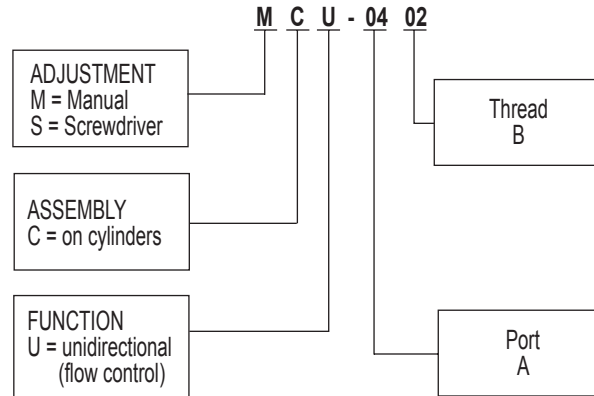

SCU



Thread B

*UNF Thread

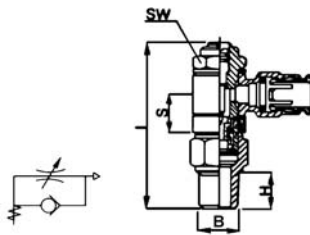

Catalog Number	Tube O.D.	B NPTF	S	H	L	SW (mm)
A55SCUx2.5x2	5/32	1/8	.51	.37	2.00	14
A55SCUx4x2	1/4	1/8	.51	.37	2.00	14
A55SCUx4x4	1/4	1/4	.45	.51	2.25	17
A55SCUx6x4	3/8	1/4	.45	.51	2.25	17
A55SCUx6x6	3/8	3/8	.48	.51	2.44	19

SCU



Thread B

*UNF Thread

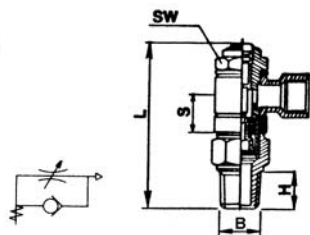

Catalog Number	Banjo Female Thread	B NPTF	S	H	L	SW (mm)
A557SCUxAxA	5/16	10-32*	.22	.18	1.14	8
A557SCUx2x2	1/8	1/8	.51	.37	2.00	14
A557SCUx4x4	1/4	1/4	.45	.51	2.25	17
A557SCUx6x6	3/8	3/8	.48	.51	2.44	19

MCU



Thread B

Port A

*UNF Thread

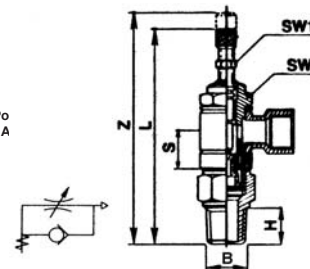

Catalog Number	Banjo Female Thread	B NPTF	S	H	L	Z	SW (mm)	SW1 (mm)
A557MCUx2x2	1/8	1/8	.51	.37	2.38	2.56	14	7
A557MCUx6x6	3/8	3/8	.48	.51	2.95	3.25	19	10

Weatherhead[®] is proud to announce three design changes to Weatherhead's Push > Connect[™] fittings. The introduction of a low profile, sure-seal design for male NPTF threaded fittings is here. Also, an improved collet design will allow use with all types of tubing from Nylon to 90A durometer Polyurethane, including Polyethylene, and PVC tubing. Lastly, the male swivel design provides greater strength and stability.

Below is a summary of features and benefits for the newly named **Push > Connect[™] Plus**.

Perfect thread seal – A captured Teflon[®] ring around the base of the hex shoulder, seals similar to a reusable (SAE type) seal eliminates thread sealant and loose particles associated with thread sealant.

Lower profile – Push > Connect[™] Plus has a lower profile for those tight places. A shorter thread design eliminates exposed threads where dirt and bacteria can collect (ideal for food processing and hygienic applications).

More versatility – The new brass collet is designed for use with all types of tubing from Nylon to 90A durometer Polyurethane, including Polyethylene, and PVC tubing.

Super-quick installations – New short thread length means fewer turns and super-quick installations.

Improved swivel design – Strength and stability have been engineered into the new male swivel.

The new part will have a 'P' in the part number to signify the new design. An example of this change is previous #1169x4S becomes #1169Px4S and the price for old and new is the same. Current Push > Connect[™] parts with 10-32UNF threads and ending in 'A' (eg. 1168x2A) will continue with the current thread design.

Swivel Male "Y"

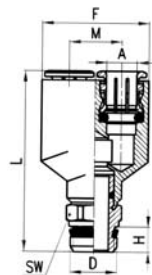

Tube O.D.	Male Pipe Thread	Catalog Number	F	H	M	L
1/8	1/8	1108Px2S	.83	.20	.39	1.28
5/32	1/8	1108Px2.5S	.83	.20	.39	1.28
1/4	1/8	1108Px4S	.96	.20	.49	1.40

Male Connector

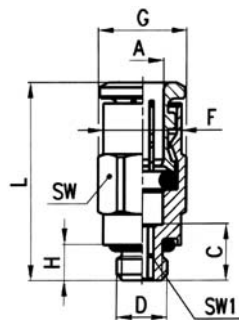

Tube O.D.	Male Pipe Thread	Catalog Number	F	G	H	L	SW (mm)	SW1 (mm)
1/8	10-32*	1168Px2A	.346	.411	.177	.846	9	2.0
1/8	1/8	1168Px2	.346	.551	.200	.728	12	2.5
1/8	1/4	1168Px2x4	.346	.629	.255	.807	14	2.5
5/32	10-32*	1168x2.5A	.346	.411	.177	.807	9	2.0
5/32	1/8	1168Px2.5	.346	.551	.200	.728	12	2.5
5/32	1/4	1168Px2.5x4	.346	.629	.255	.807	14	2.5
1/4	10-32*	1168x4A	.460	.551	.177	.905	12	2.0
1/4	1/8	1168Px4	.460	.551	.200	.807	12	4.0
1/4	1/4	1168Px4x4	.460	.629	.255	.846	14	4.0
1/4	3/8	1168Px4x6	.460	.866	.294	.885	19	4.0
5/16	1/8	1168Px5	.539	.629	.200	.945	14	5.0
5/16	1/4	1168Px5x4	.539	.629	.255	.945	14	6.0
5/16	3/8	1168Px5x6	.539	.866	.294	.924	19	6.0
3/8	1/8	1168Px6x2	.641	.776	.200	1.082	17	5.0
3/8	1/4	1168Px6	.641	.776	.255	1.102	17	7.0
3/8	3/8	1168Px6x6	.641	.866	.294	.945	19	7.0
3/8	1/2	1168Px6x8	.641	1.004	.335	.984	22	7.0
1/2	3/8	1168Px8	.720	.866	.294	1.161	19	10.0
1/2	1/4	1168Px8x4	.720	.866	.255	1.161	19	7.0
1/2	1/2	1168Px8x8	.720	1.004	.335	1.062	22	10.0

*UNF Thread

Swivel Male Elbow

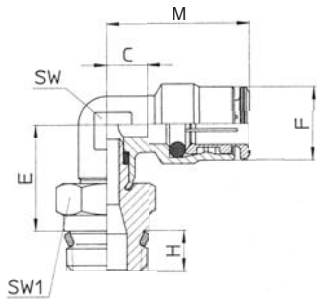

NOTE: Swivel for installation purposes only.

Tube O.D.	Male Pipe Thread	Catalog Number	C	E	F	H	M	SW (mm)	SW1 (mm)
1/8	1/8	1169Px2S	.24	.59	.35	.20	.81	9	12
1/8	1/4	1169Px2x4S	.24	.63	.35	.26	.81	9	14
5/32	1/8	1169Px2.5S	.24	.59	.35	.20	.79	9	12
5/32	1/4	1169Px2.5x4S	.24	.63	.35	.26	.79	9	14
1/4	1/8	1169Px4S	.27	.63	.46	.20	.89	10	12
1/4	1/4	1169Px4x4S	.27	.65	.46	.26	.89	10	14
1/4	3/8	1169Px4x6S	.27	.65	.46	.29	.89	12	19
5/16	1/8	1169Px5S	.30	.65	.54	.20	.96	12	12
5/16	1/4	1169Px5x4S	.30	.69	.54	.26	.96	12	14
5/16	3/8	1169Px5x6S	.30	.69	.54	.29	.96	12	19
3/8	1/8	1169Px6x2S	.34	.75	.64	.20	1.10	14	14
3/8	1/4	1169Px6S	.34	.77	.64	.26	1.10	14	14
3/8	3/8	1169Px6x6S	.34	.77	.64	.29	1.10	14	19
3/8	1/2	1169Px6x8S	.34	.79	.64	.34	1.10	14	22
1/2	1/4	1169Px8x4S	.39	.81	.72	.26	1.20	17	17
1/2	3/8	1169Px8S	.39	.81	.72	.29	1.20	17	19
1/2	1/2	1169Px8x8S	.39	.83	.72	.36	1.20	17	22

Male Run Tee Swivel

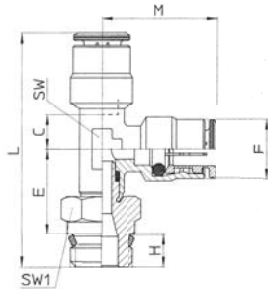

NOTE: Swivel for installation purposes only.

Tube O.D.	Male Pipe Thread	Catalog Number	C	E	F	H	L	M	SW (mm)	SW1 (mm)
1/8	1/8	1171Px2S	.24	.59	.35	.20	1.59	.81	9	12
5/32	1/8	1171Px2.5S	.24	.59	.35	.20	1.57	.79	9	12
5/32	1/4	1171Px2.5x4S	.24	.63	.35	.26	1.67	.79	9	14
1/4	1/8	1171Px4S	.27	.61	.46	.20	1.69	.89	10	12
1/4	1/4	1171Px4x4S	.27	.65	.46	.26	1.79	.89	10	14
1/4	3/8	1171Px4x6S	.27	.65	.46	.29	1.83	.89	12	19
3/8	1/4	1171Px6S	.34	.77	.64	.26	2.13	1.10	14	14
3/8	3/8	1171Px6x6S	.34	.77	.64	.29	2.17	1.10	14	19
3/8	1/2	1171Px6x8S	.34	.79	.64	.34	2.22	1.10	14	22
1/2	1/4	1171Px8x4S	.39	.81	.72	.26	2.26	1.20	17	17
1/2	3/8	1171Px8S	.39	.81	.72	.29	2.30	1.20	17	19
1/2	1/2	1171Px8x8S	.39	.83	.72	.34	2.36	1.20	17	22

Male Branch Tee Swivel

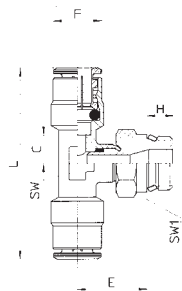

NOTE: Swivel for installation purposes only.

Tube O.D.	Male Pipe Thread	Catalog Number	C	E	F	H	L	SW (mm)	SW1 (mm)
1/8	1/8	1172Px2S	.24	.59	.35	.20	1.61	9	12
5/32	1/8	1172Px2.5S	.24	.59	.35	.20	1.57	9	12
5/32	1/4	1172Px2.5x4S	.24	.63	.35	.26	1.57	9	14
1/4	1/8	1172Px4S	.27	.61	.46	.20	1.77	10	12
1/4	1/4	1172Px4x4S	.27	.65	.46	.26	1.77	10	14
1/4	3/8	1172Px4x6S	.27	.65	.46	.29	1.77	12	19
3/8	1/4	1172Px6S	.34	.77	.64	.26	2.20	14	14
3/8	3/8	1172Px6x6S	.34	.77	.64	.29	2.20	14	19
3/8	1/2	1172Px6x8S	.34	.79	.64	.34	2.20	14	22
1/2	1/4	1172Px8x4S	.39	.81	.72	.26	2.40	17	17
1/2	3/8	1172Px8S	.39	.81	.72	.29	2.40	17	19
1/2	1/2	1172Px8x8S	.39	.83	.72	.34	2.40	17	22

⚠ Refer to safety information regarding proper selection of tubing and tube fittings on page 1.

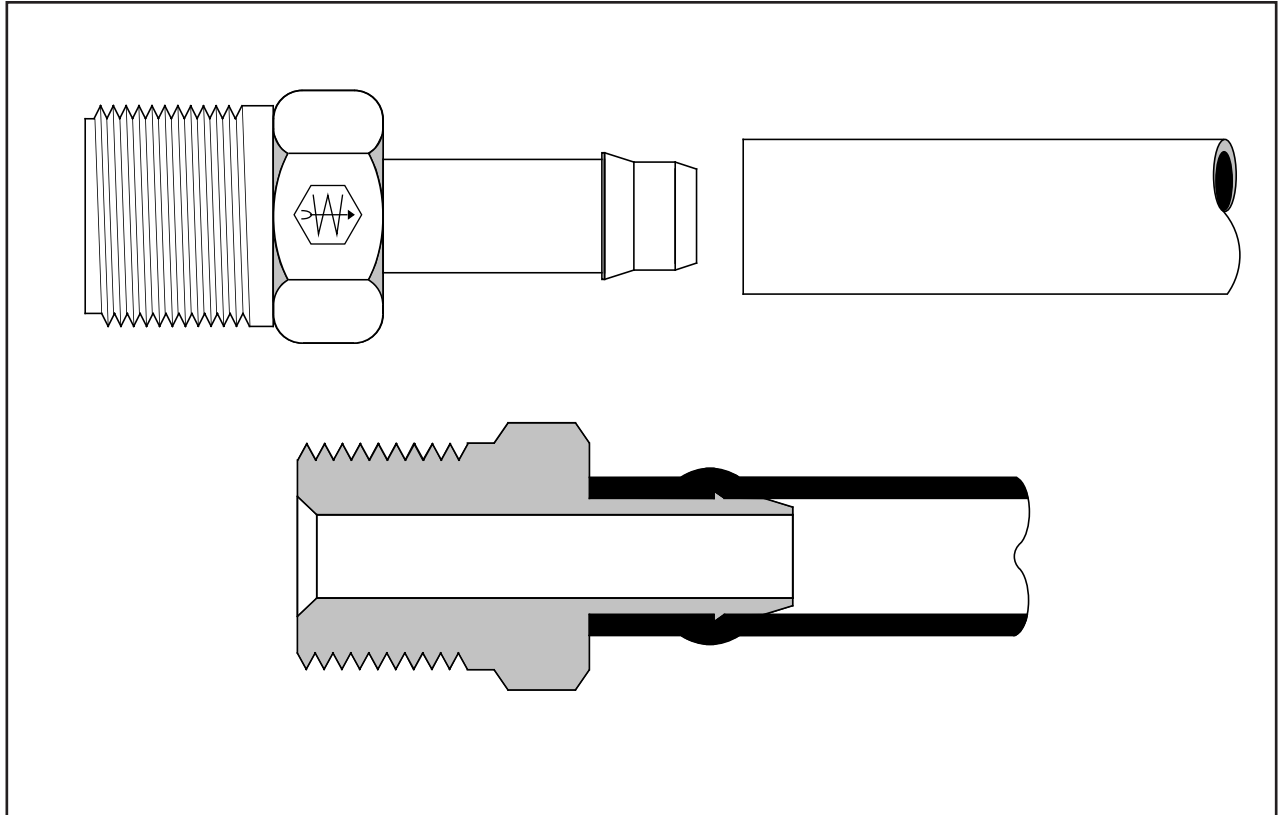

BRASS

- **Typical Application**
Temperature control circuits, test apparatus, lubricant, coolant lines, pneumatic circuits, vacuum and fluid systems.
- **Pressure**
Will withstand burst pressures of plastic tubing.
- **Vibration**
Excellent resistance.
- **Temperature Range**
Depends on tubing used.
- **Material**
CA360 Brass.

- **Used With**
PT240 Polyethylene tubing. See page 28-32 for material compatibility and page 33-35 for plastic tubing.
- **Advantages**
Quick connecting - no tube preparation. Hand assembly. Low cost one-piece push-on design. Barbed lip provides safe, positive connection. Compact size permits use in extremely tight areas.
- **Conformance**
An exclusive item with Weatherhead. User approvals only.

- **How to Order**
Individually by catalog number.
- **NOTE**
Refer to current price list for availability of cataloged items. Quotations and delivery of non-stock items supplied on request. Configurations and dimensions subject to change without notice.
- **Assembly Instructions**
 1. Push the tubing over insert.
 2. Bottom the tubing against fitting body.

Label Set: **FS-1000** (adhesive)
CL-496 (non-adhesive)

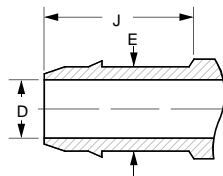

Common Dimensions of Barbed End

Tubing O.D.	D	E	J
5/32	.062	.113	.38
*3/16	.078	.125	.50
1/4	.127	.189	.50
3/8	.196	.270	.50
1/2	.312	.395	.63

*No barb on 3/16" size.

Plug

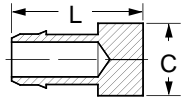
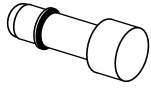

Tubing O.D.	Catalog Number	Dia. C	L
1/4	1073x4	.31	.75
3/8	1073x6	.40	.75
1/2	1073x8♦	.53	.88

Solder Connector

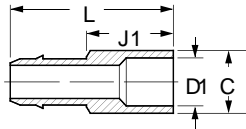
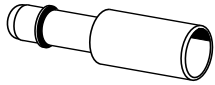

Tubing O.D.	Solder Conn.	Catalog Number	Dia. C	D1	J1	L
1/4	1/4	1079x4x4	5/16	.25	.50	1.00

Union

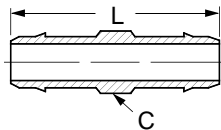
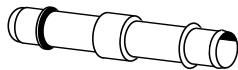

*No barb on 3/16" end.
"L" Suffix designates long Union.

Tubing O.D.	Catalog Number	Dia. C	L
1/4x3/16*	1062x4x3	1/4	1.25
1/4	1062x4	1/4	.81
1/4	1062x4L	1/4	1.25
3/8x1/4	1062x6x4	5/16	1.19
3/8	1062x6	5/16	1.19
1/2x1/4	1062x8x4♦	1/2	1.33
1/2x3/8	1062x8x6	1/2	1.33
1/2	1062x8	1/2	1.45

Male Connector

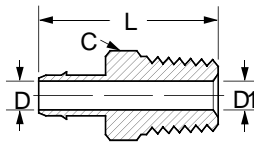
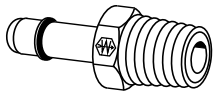

*UNF Thread

Tubing O.D.	Male Pipe Thread	Catalog Number	Hex C	D	D1 Opt.	L
5/32	1/8	1068x2.5x2	7/16	.06	.19	.98
1/4	1/16	1068x4x1	5/16	.12	-	1.06
1/4	1/8	1068x4	7/16	.12	.19	1.06
1/4	1/4	1068x4x4	9/16	.12	.28	1.28
3/8	1/8	1068x6x2	7/16	.19	-	1.09
3/8	1/4	1068x6	9/16	.19	.28	1.28
3/8	1/2	1068x6x8♦	7/8	.19	.56	1.41
1/2	3/8	1068x8	11/16	.31	-	1.38

Female Connector

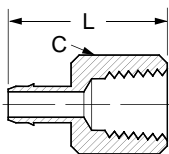
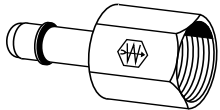

*PTF Short Thread

Tubing O.D.	Fem. Pipe Thread	Catalog Number	Hex C	L
1/4	1/8*	1066x4	1/2	1.00
1/4	1/4	1066x4x4	11/16	1.25
3/8	1/4	1066x6♦	11/16	1.25

Compression Connector

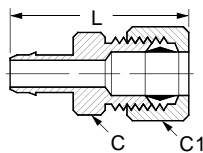
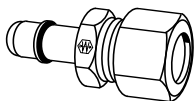

*No Barb on 3/16" end
For replacement nuts and sleeves see page 49.

Tubing O.D.	Comp. Tube Size	Catalog Number	Hex C	Hex C1	L
3/16*	1/4	1078x3x4	7/16	1/2	1.29
1/4	1/4	1078x4x4	7/16	1/2	1.29

Bulkhead Compression Connector

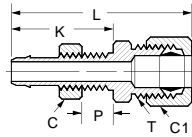
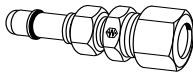

For replacement compression nuts and sleeves, see page 49.

Tubing O.D.	Comp. Tube Size	Catalog Number	Hex C	Hex C1	K	L	Max. P	T Thread
1/4	1/4	1067x4x4	7/16	1/2	.88	1.66	.19	5/16-24 UNF
3/8	3/8	1067x6x6♦	9/16	5/8	1.06	1.94	.31	3/8-24 UNF

Bulkhead Union

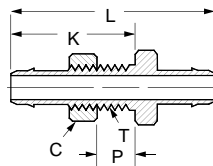
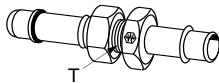

For replacement nuts and sleeves, see page 50.

Tubing O.D.	Thread T	Catalog Number	Hex C	K	L	Max. P
1/4	5/16-24 UNF	1074x4	7/16	1.06	1.74	.31
3/8	3/8-24 UNF	1074x6	1/2	1.06	1.74	.31

Union Elbow

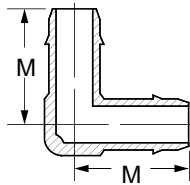
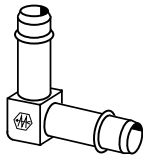

Tubing O.D.	Catalog Number	M
1/4	1065x4	.70
3/8	1065x6	.67
1/2	1065x8	.86

90° Male Elbow

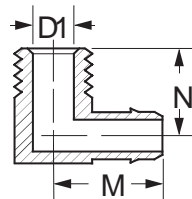
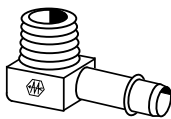

*PTF Short Thread

Tubing O.D.	Male Pipe Thread	Catalog Number	D1	M	N
1/4	1/16	1069x4x1	.156	.67	.55
1/4	1/8	1069x4	.250	.72	.63
1/4	1/4*	1069x4x4	.312	.78	.65
3/8	1/8	1069x6x2	.250	.74	.59
3/8	1/4*	1069x6	.312	.78	.62
1/2	3/8*	1069x8	.406	.98	.81

90° Female Elbow

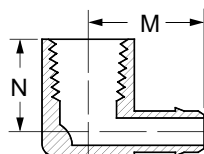
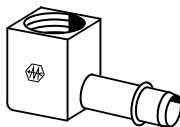

Tubing O.D.	Fem. Pipe Thread	Catalog Number	M	N
1/4	1/8	1070x4	.75	.58
3/8	1/8	1070x6x2	.78	.48
3/8	1/4	1070x6	.84	.81

♦MTO - Made To Order

Union Tee

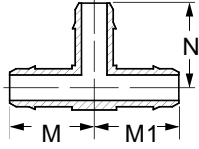
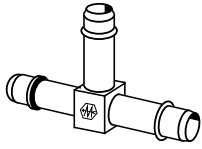

Tubing O.D.	Catalog Number	M	N	M1
1/4	1064x4	.70	.70	.70
3/8x3/8x1/4	1064x6x6x4	.70	.74	.70
3/8	1064x6	.68	.67	.68
3/8x1/2x3/8	1064x6x8x6	.67	.73	.79
1/2x1/2x1/4	1064x8x8x4	.82	.80	.82
1/2x1/2x3/8	1064x8x8x6	.79	.73	.79
1/2	1064x8	.86	.86	.86

Male Run Tee

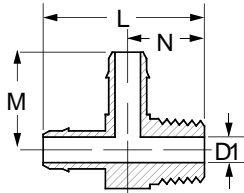
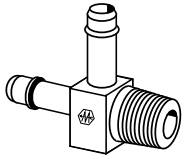

*PTF Short Thread

Tubing O.D.	Male Pipe Thread	Catalog Number	D1	L	M	N
1/4	1/8	1071x4	.188	1.21	.71	.59
3/8	1/8	1071x6x2	.188	1.26	.71	.59
3/8	1/4*	1071x6*	.312	1.26	.78	.61

Male Branch Tee

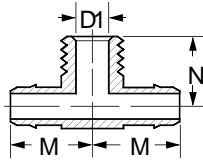
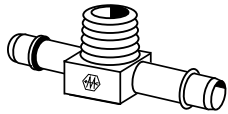

Tubing O.D.	Male Pipe Thread	Catalog Number	D1	M	N
1/4	1/16	1072x4x1♦	.156	.67	.55
1/4	1/8	1072x4	.188	.72	.59
3/8	1/8	1072x6x2	.188	.72	.59
3/8	1/4	1072x6	.312	.78	.62

Female Branch Tee

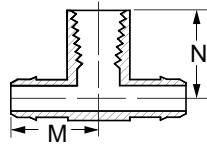
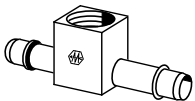

Tubing O.D.	Female Pipe Thread	Catalog Number	M	N
1/4	1/8	1077x4	.77	.48

Adapter Tee

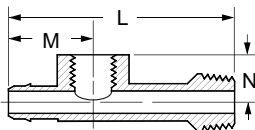
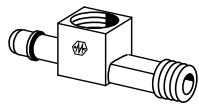

*PTF Special Short Thread

Tubing O.D.	M&F Pipe Thread	Catalog Number	L	M	N
1/4	1/8*	1075x4	2.00	.75	.39

 Refer to safety information regarding tubing selection on page 1.

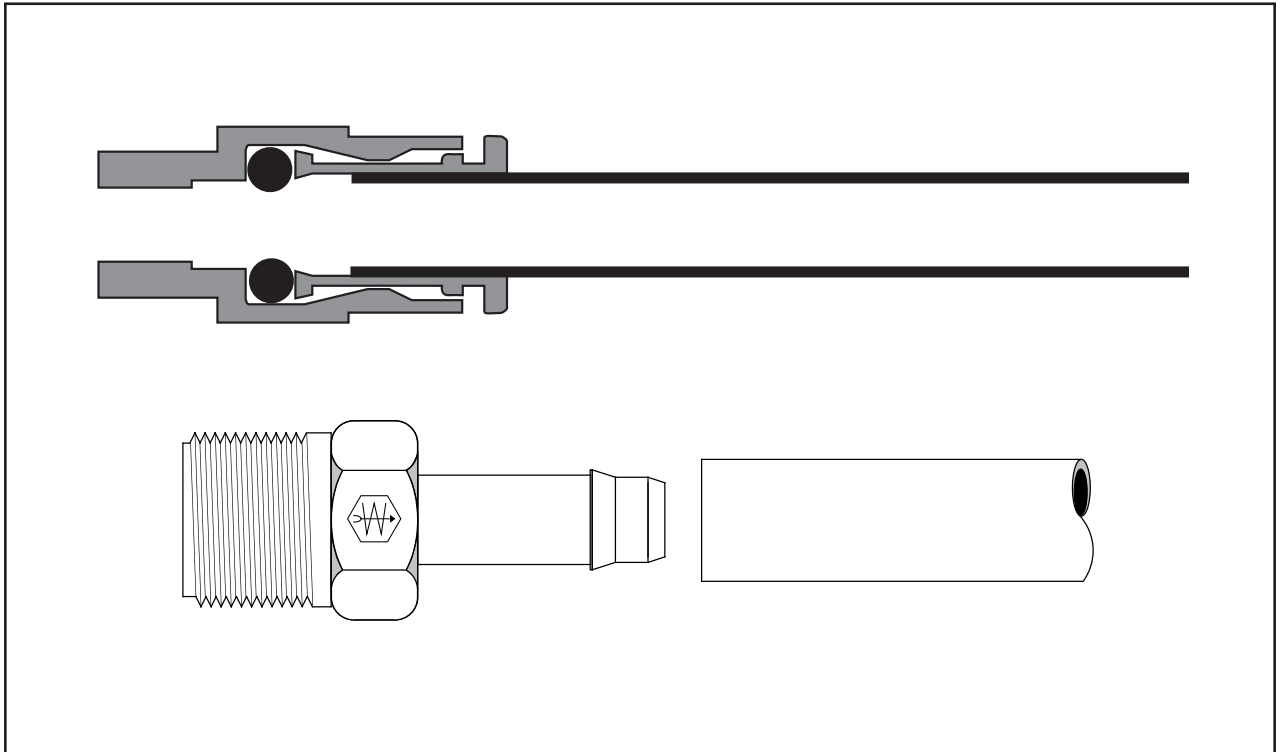

- **Typical Application**
Air brake systems except where temperatures exceed +200°F or where battery acid can drip on tubing. Not for fuel, water or oil.
- **Pressure**
Vacuum to 150 psi.
- **Vibration**
Moderate vibration resistance.
- **Material**
CA360 Brass (Body & Collet).
EP (Ethylene Propylene) - O-ring.
- **Used With**
NT100 Nylon Tubing - SAE J844 Type A and B. See page 33 for NT100 Nylon Tubing data.
- **Temperature Range**
-40°F to +200°F (-40°C to +93°C)
- **Advantages**
Easy, fast assembly, one-piece fitting, reusable Field Serviceable (See collet repair kits, page 58).
- **Conformance**
Meets D.O.T. FMVSS 571.106 and SAE J1131 air brake system performance requirements.
- **How to Order**
Order individually by catalog number (parts are standard with thread sealant).
- **NOTE**
Refer to current price list for availability of cataloged items. Quotations and delivery of non-stock items supplied on request. Configurations and dimensions subject to change without notice. Additional information can be found in SAE J2494.
- **Assembly Instructions**
See following page.
- **Cartridge Information**

Encapsulated – For insertion into single bore cavity in substitution for pipe thread ports. Meets proposed SAE specifications for encapsulated press in style Air Brake Fittings. Note: Weatherhead Encapsulated Cartridges are specifically designed for installation into a thermoplastic (Nylon/Glass filled Nylon/Acetal) or a soft metal (Aluminum/Brass) cavity. For cavity dimensions contact 1-800-336-5005.

Four-Step Cartridge – When you clean sheet a component design, the Four-Step Cartridge is an economical substitute for the encapsulated design. Special order only.

Select the design that is right for you. For applications where manifolds (manufactured from aluminum, plastic and brass) and air tanks (manufactured from steel and plastic composites) are used, contact Weatherhead Technical Support at 1-800-776-3262 for quotes based on your specific requirements and volumes.

Label Set: **FS-3300** (adhesive)
CL-503 (non-adhesive)

Assembly

1. Using a tube cutter, make a square cut edge (maximum 15° cutting angle allowed).

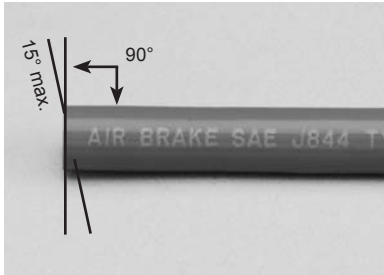

2. Insert tubing straight into fitting until a solid stop is felt. The tubing grip and seal (on O-ring) is now accomplished.

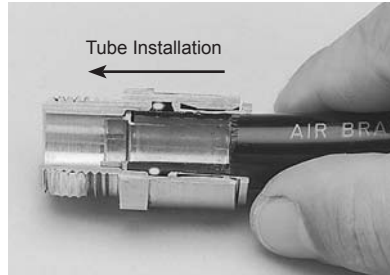

3. Gently tug on tubing to ensure tubing is secure.

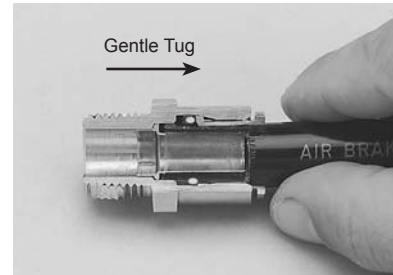

Disassembly

1. Check to be sure there isn't any air pressure.

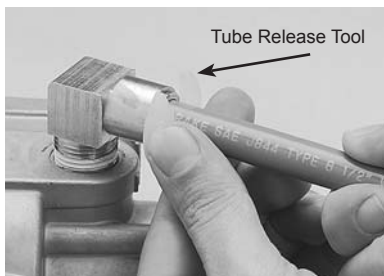

2. Depress collet head using fingers or Weatherhead® tube-release tool to release grip on tubing.

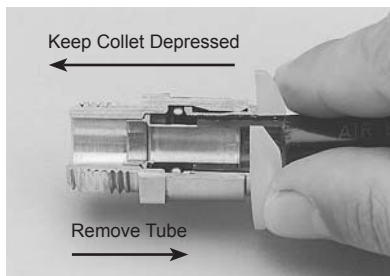

3. With the collet depressed, pull the tubing from the fitting.

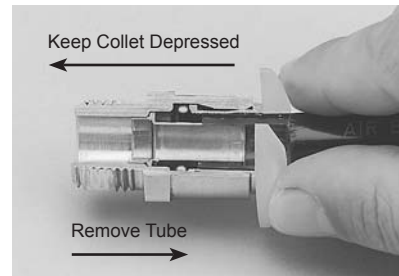

Quick > Connect[®] Air Brake

**Brass
Fittings**

Use with Weatherhead NT100 Air Brake Tubing (SAE J844), see page 33.

Encapsulated Cartridge

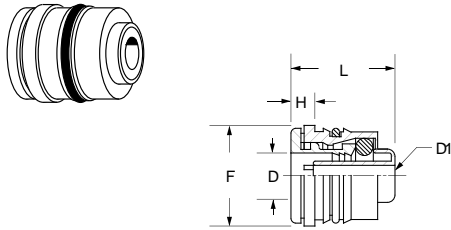

NOTE: For design installation reference page 83 under Encapsulated heading.

Tube O.D.	Catalog Number	Dia F	L	D1	D	H
5/32	1861x2.5	.38	.62	.12	.165	.17
3/16	1861x3	.44	.62	.12	.195	.16
1/4	1861x4	.56	.65	.13	.263	.17
3/8	1861x6	.69	.81	.22	.388	.19
1/2	1861x8	.81	.83	.34	.513	.19
5/8	1861x10	.97	.99	.40	.638	.24
3/4	1861x12	1.12	.99	.52	.763	.24

Union

(Ref. SAE No. AA0101)

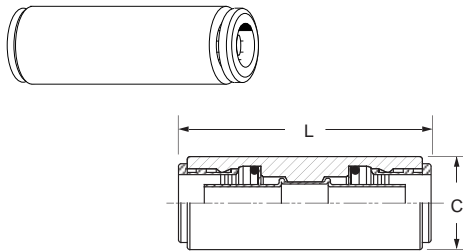

NOTE: Joins tubing

Tube O.D.	Catalog Number	Dia C	L
5/32	1862x2.5	.44	1.41
3/16	1862x3	.44	1.62
1/4	1862x4	.53	1.62
3/8	1862x6	.69	1.94
1/2	1862x8	.83	1.96
5/8	1862x10	.96	2.51

Quick Connect Bulkhead Union

(Ref. SAE No. AA0601)

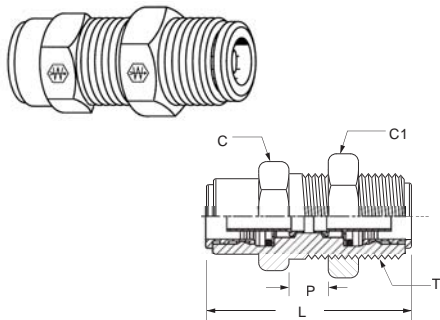

Tube O.D.	Tread T	Catalog Number	Hex C	Hex C1	L	Max P
1/4	9/16-24	1874x4x4	5/8	11/16	1.62	.47
3/8	3/4-16	1874x6x6	7/8	15/16	1.96	.66
1/2	7/8-14	1874x8x8	1	1	2.00	.83
5/8	1-14	1874x10x10	1	1-1/4	2.42	1.00

Female Bulkhead Union

(Ref. SAE No. AA0603)

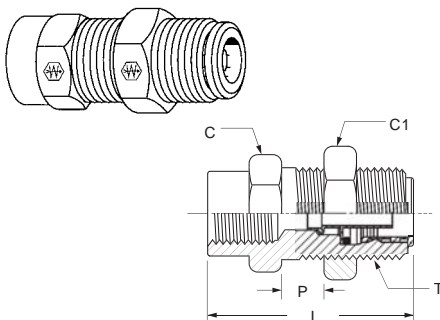

Tube O.D.	Thread T	Female Pipe Thread	Catalog Number	Hex C	Hex C1	L
1/4	9/16-24	1/4	1873x4x4	5/8	11/16	1.45
3/8	3/4-16	3/8	1873x6x6	7/8	15/16	1.59
1/2	1-14	1/2	1873x8x8	1	1-1/4	1.97

BRASS

Use with Weatherhead NT100 Air Brake Tubing (SAE J844), see page 33.

Male Connector
(Ref. SAE No. AA0102)

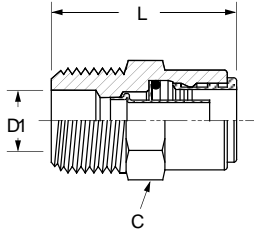
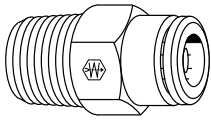

Tube O.D.	Male Pipe Thread	Catalog Number	Hex C	D1	L
5/32	1/16	1868x2.5x1	3/8	.09	.92
5/32	1/8	1868x2.5	7/16	.25	.92
3/16	1/8	1868x3	1/2	.25	.92
1/4	1/8	1868x4	9/16	.19	.95
1/4	1/4	1868x4x4	9/16	.34	1.18
1/4	3/8	1868x4x6	11/16	.41	1.17
3/8	1/8	1868x6x2	11/16	.19	1.33
3/8	1/4	1868x6	11/16	.31	1.29
3/8	3/8	1868x6x6	11/16	.41	1.27
3/8	1/2	1868x6x8	7/8	.53	1.47
1/2	1/4	1868x8x4	13/16	.31	1.46
1/2	3/8	1868x8	13/16	.41	1.35
1/2	1/2	1868x8x8	7/8	.53	1.50
5/8	3/8	1868x10x6	1	.41	1.72
5/8	1/2	1868x10	1	.53	1.71
3/4	1/2	1868x12	1-1/16	.53	1.72

Female Connector
(Ref. SAE No. AA0103)

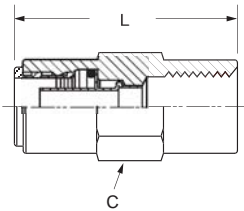
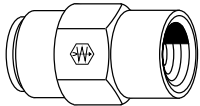

Tube O.D.	Female Pipe Thread	Catalog Number	Hex C	L
1/4	1/8	1866x4	9/16	1.33
1/4	1/4	1866x4x4	11/16	1.58
3/8	1/8	1866x6x2	11/16	1.45
3/8	1/4	1866x6	11/16	1.69
3/8	3/8	1866x6x6	13/16	1.75
1/2	1/4	1866x8x4	13/16	1.66
1/2	3/8	1866x8	13/16	1.73
1/2	1/2	1866x8x8	1	1.97

45° Male Elbow
(Ref. SAE No. AA0302)

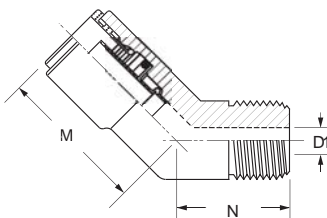
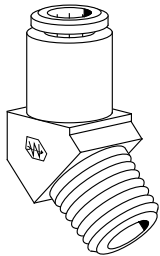

Tube O.D.	Male Pipe Thread	Catalog Number	D1	M	N
1/4	1/8	1880x4	.19	.95	.59
1/4	1/4	1880x4x4	.31	.95	.59
3/8	1/8	1880x6x2	.25	1.05	.48
3/8	1/4	1880x6	.31	1.05	.69
3/8	3/8	1880x6x6	.41	1.10	.63
3/8	1/2	1880x6x8	.53	1.20	.70
1/2	1/4	1880x8x4	.31	1.20	.87
1/2	3/8	1880x8	.41	1.10	.73
1/2	1/2	1880x8x8	.53	1.10	.76
5/8	3/8	1880x10x6	.41	1.25	.82
5/8	1/2	1880x10	.53	1.39	.90
3/4	1/2	1880x12	.53	1.26	.98

Quick > Connect[®] Air Brake

**Brass
Fittings**

Use with Weatherhead NT100 Air Brake Tubing (SAE J844), see page 33.

45° Elbow - Swivel Male (Ref. SAE No. AA03DD)

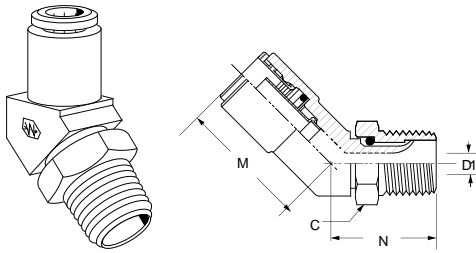

NOTE: Swivel for installation purposes only.

Tube O.D.	Male Pipe Thread	Catalog Number	D1	M	N	Hex C
1/4	1/8	1880x4S	.13	.82	.60	7/16
1/4	1/4	1880x4x4S	.22	.98	.60	9/16
3/8	1/8	1880x6x2S	.13	1.20	.68	7/16
3/8	1/4	1880x6S	.22	1.20	.82	9/16
3/8	3/8	1880x6x6S	.30	1.20	.97	11/16
1/2	1/4	1880x8x4S	.22	1.20	1.20	9/16
1/2	3/8	1880x8S	.30	1.04	1.07	11/16
1/2	1/2	1880x8x8S	.42	1.08	1.22	7/8

90° Union Elbow (Ref. SAE No. AA0201)

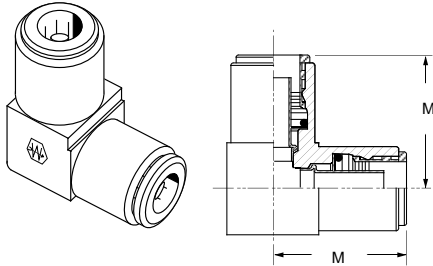

Tube O.D.	Catalog Number	M
1/4	1865x4	.93
3/8	1865x6	1.15
1/2	1865x8	1.24

90° Male Elbow (Ref. SAE No. AA0302)

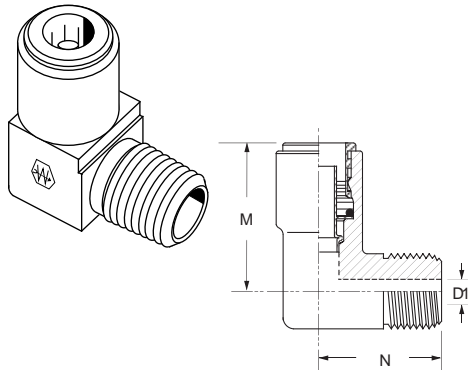

Tube O.D.	Male Pipe Thread	Catalog Number	D1	M	N
5/32	1/16	1869x2.5x1	.13	.75	.59
5/32	1/8	1869x2.5	.19	.75	.59
3/16	1/8	1869x3	.19	.84	.69
1/4	1/8	1869x4	.19	.92	.68
1/4	1/4	1869x4x4	.31	.92	.81
1/4	3/8	1869x4x6	.41	1.03	.82
3/8	1/8	1869x6x2	.19	1.08	.80
3/8	1/4	1869x6	.31	1.13	.96
3/8	3/8	1869x6x6	.41	1.20	.99
3/8	1/2	1869x6x8	.53	1.27	1.07
1/2	1/4	1869x8x4	.31	1.23	1.00
1/2	3/8	1869x8	.41	1.25	.98
1/2	1/2	1869x8x8	.53	1.25	1.11
5/8	3/8	1869x10x6	.41	1.44	1.09
5/8	1/2	1869x10	.53	1.48	1.22

90° Male Elbow Long

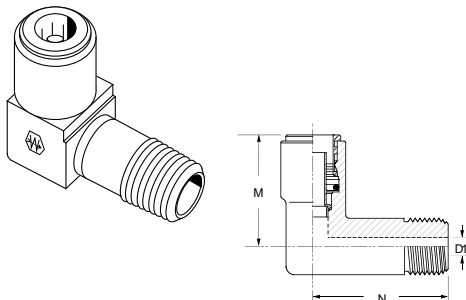

Tube O.D.	Male Pipe Thread	Catalog Number	D1	M	N
3/8	1/4	1869x6L	.31	1.21	1.55

BRASS

Use with Weatherhead NT100 Air Brake Tubing (SAE J844), see page 33.

90° Swivel Male Elbow (Ref. SAE No. AA02DD)

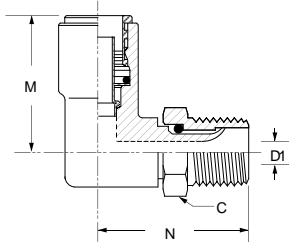
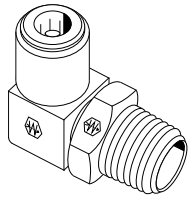

NOTE: Swivel for installation purposes only.

Tube O.D.	Male Pipe Thread	Catalog Number	D1	M	N	Hex C
1/4	1/8	1869x4S	.13	.89	.88	7/16
1/4	1/4	1869x4x4S	.22	.99	1.06	9/16
1/4	3/8	1869x4x6S	.30	.98	1.06	11/16
3/8	1/8	1869x6x2S	.13	1.03	.97	7/16
3/8	1/4	1869x6S	.22	1.10	1.14	9/16
3/8	3/8	1869x6x6S	.30	1.12	1.15	11/16
3/8	1/2	1869x6x8S	.42	1.18	1.40	7/8
1/2	1/4	1869x8x4S	.22	1.08	1.20	9/16
1/2	3/8	1869x8S	.30	1.13	1.27	11/16
1/2	1/2	1869x8x8S	.42	1.20	1.47	7/8
5/8	3/8	1869x10x6S	.42	1.35	1.34	11/16
5/8	1/2	1869x10S	.42	1.38	1.54	7/8

90° Female Elbow (Ref. SAE No. AA0203)

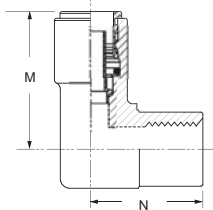
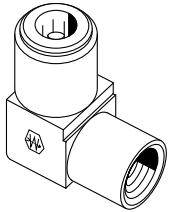

Tube O.D.	Female Pipe Thread	Catalog Number	M	N
1/4	1/8	1870x4	1.03	.83
1/4	1/4	1870x4x4	1.04	.78
3/8	1/8	1870x6x2	1.13	.96
3/8	1/4	1870x6	1.28	1.09
3/8	3/8	1870x6x6	1.21	1.07
1/2	1/4	1870x8x4	1.25	1.11
1/2	3/8	1870x8	1.22	1.11
1/2	1/2	1870x8x8	1.33	1.07

Union Tee (Ref. SAE No. AA0401)

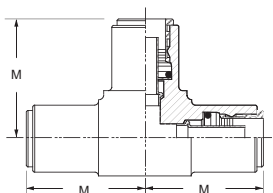
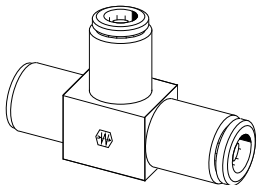

Tube O.D.	Catalog Number	M
1/4	1864x4	.93
3/8	1864x6	1.15
1/2	1864x8	1.22

Quick > Connect[®] Air Brake

**Brass
Fittings**

Use with Weatherhead NT100 Air Brake Tubing (SAE J844), see page 33.

Male Run Tee (Ref. SAE No. AA0424)

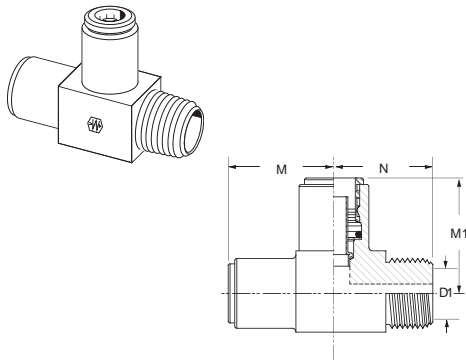

Tube O.D.	Male Pipe Thread	Catalog Number	D1	M	M1	N
1/4	1/8	1871x4	.19	.93	.93	.64
1/4	1/4	1871x4x4	.19	.93	.94	.82
3/8	1/4	1871x6	.31	1.14	1.14	.91
3/8	3/8	1871x6x6	.41	1.15	1.15	.91
3/8x1/4	1/4	1871x6x4x4	.31	1.14	1.07	.96
3/8	1/2	1871x6x8	.53	1.09	1.08	1.11
1/2	3/8	1871x8	.41	1.09	1.10	1.22

Swivel Male Run Tee (Ref. SAE No. AA04EE)

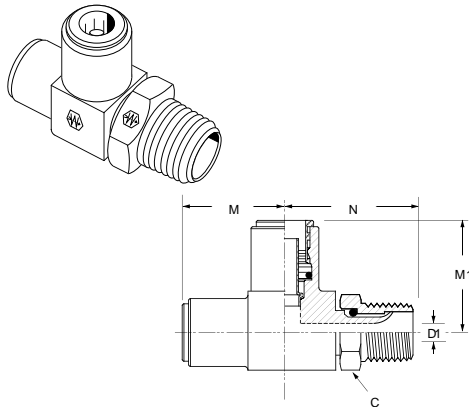

NOTE: Swivel for installation purposes only.

Tube O.D.	Male Pipe Thread	Catalog Number	D1	M	M1	N	Hex C
1/4	1/8	1871x4S	.13	.92	.92	.82	7/16
1/4	1/4	1871x4x4S	.22	.93	.92	1.07	9/16
3/8	1/4	1871x6S	.22	1.15	1.15	1.20	9/16
3/8	3/8	1871x6x6S	.30	1.15	1.15	1.20	11/16
1/2	1/4	1871x8x4S	.22	1.21	1.18	1.22	9/16
1/2	3/8	1871x8S	.30	1.21	1.23	1.34	11/16
1/2	1/2	1871x8x8S	.42	1.21	1.19	1.42	7/8

B
R
A
S
S

Male Branch Tee (Ref. SAE No. AA0425)

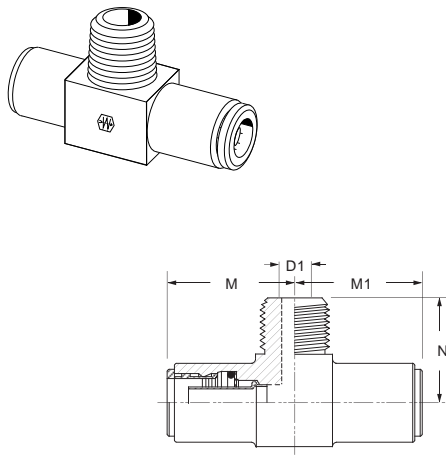

Tube O.D.	Male Pipe Thread	Catalog Number	D1	M	M1	N
3/16	1/8	1872x3	.19	.75	.74	.64
1/4	1/8	1872x4	.19	.93	.93	.64
1/4	1/4	1872x4x4	.19	.93	.93	.82
3/8	1/4	1872x6	.31	1.15	1.15	.91
3/8	3/8	1872x6x6	.31	1.15	1.15	.92
1/2	1/4	1872x8x4	.31	1.22	1.22	.98
1/2	3/8	1872x8	.41	1.24	1.24	.99
1/2	1/2	1872x8x8	.53	1.22	1.22	1.12

Use with Weatherhead NT100 Air Brake Tubing (SAE J844), see page 33.

Swivel Male Branch Tee (Ref. SAE No. AA04FF)

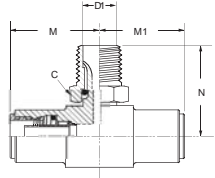
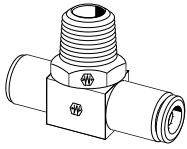

NOTE: Swivel for installation purposes only.

Tube O.D.	Male Pipe Thread	Catalog Number	D1	M	M1	N	Hex C
1/4	1/8	1872x4S	.13	.93	.93	.80	7/16
1/4	1/4	1872x4x4S	.22	.93	.93	1.04	9/16
3/8	1/8	1872x6x2S	.13	1.15	1.15	.94	7/16
3/8	1/4	1872x6S	.22	1.15	1.15	1.14	9/16
3/8	3/8	1872x6x6S	.30	1.15	1.15	1.17	11/16
1/2	1/4	1872x8x4S	.22	1.23	1.23	1.21	9/16
1/2	3/8	1872x8S	.30	1.24	1.24	1.24	11/16
1/2	1/2	1872x8x8S	.42	1.21	1.19	1.42	7/8

Female Branch Tee

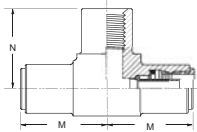
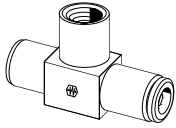

Tube O.D.	Female Pipe Thread	Catalog Number	M	N
3/8	1/4	1877x6	1.16	.78

Adapter Tee

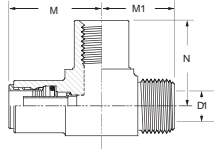
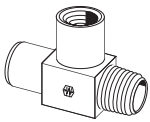

Tube O.D.	Male Pipe Thread	Female Pipe Thread	Catalog Number	D1	M	N	M1
3/8	3/8	1/4	1883x6x6x4	.41	1.28	1.00	.95

Plugs, Pressure (Nylon)

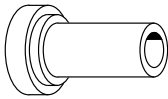

Tube O.D.	Catalog Number
1/4	1829x4
3/8	1829x6
1/2	1829x8

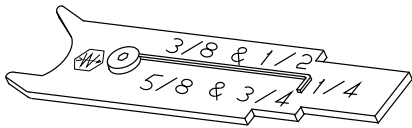

1800T • Collet Service Tool

The Collet Service Tool, made from sturdy plated steel, is designed to assist in field servicing O-Rings of Q-CAB[®] fittings. Use the half moon radius section to pry up and remove the collet and use the movable piano wire to remove the O-Ring. Notches are used to mark the tubing with insertion depth in five tubing sizes.



1800TRK • Tube Release Kit

The 1800TRK tube release kit is designed to ease the removal of tubing from Q-CAB[®] fittings. The individual tools are manufactured of a sturdy engineering plastic. All six tube sizes currently offered in Q-CAB[®] can be serviced with the five tools that make up the 1800TRK kit.

Tube O.D.	Repair Kit Part #
5/32	1800Kx2.5
3/16	1800Kx3
1/4	1800Kx4
3/8	1800Kx6
1/2	1800Kx8
5/8	1800Kx10
3/4	1800Kx12

Collet Repair Kits

Consisting of a replacement collet and a replacement o-ring, the collet repair kits provide an opportunity to repair damaged Q-CAB[®] Fittings.

Air Brake - Nylon Tubing

Brass Fittings

 Refer to safety information regarding tubing selection on page 1.

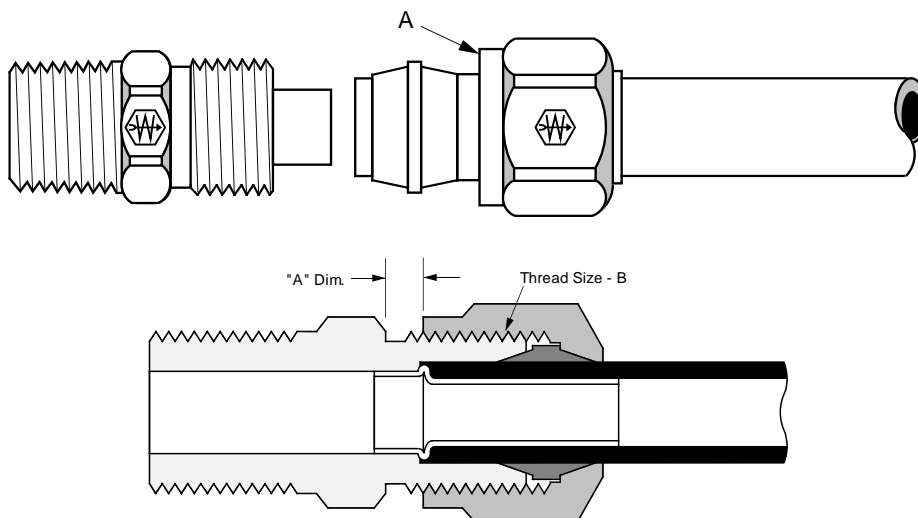

Tube O.D.	1/4	3/8	1/2	5/8	3/4
Thread Size-B	7/16-24	17/32-24	11/16-20	13/16-18	1-18

BRASS

• Typical Application

Air brake systems except where temperatures exceed +200°F or where battery acid can drip on tubing.

• Pressure

Maximum operating pressure of 150 psi.

• Vibration

Fair resistance.

• Temperature Range

-40°F to +200°F (-40°C to +93°C)

• Material

CA360 Brass.

• Used With

NT100 Nylon Tubing - SAE J844 Type A and B. See page 33 for NT100 Nylon Tubing data.

• Advantages

Easy to assemble (no tube preparation or flaring required.) Built in tube support. May be used with copper tubing by replacing nut, sleeve and insert with long nut and spherical sleeve. Insert should be removed for copper tubing use. See page 97 for details.

• Conformance

Meets specifications and standards of SAE and DOT FMVSS 571.106.

• How to Order

For complete assemblies (body, nuts and sleeves), order by catalog number. Example: 1468x4x4. To order body only (less nut and sleeve), add prefix "B" to catalog number and change "14" to "13". Example: B1368x4x4. Nuts, sleeve and insert can be ordered separately by catalog number.

To order complete assembly with pipe sealant (Seal-A-Thread), add suffix "Z" to catalog number. Example: 1468x4x4Z (special order only).

To order complete assembly with gauge ring, add suffix "K" to catalog number. Example: 1468x4x4K (special order only).

• NOTE

Refer to current price list for availability of cataloged items. Quotations and delivery of non-stock items supplied on request. Configurations and dimensions subject to change without notice. Additional information can be found in SAE J246.

• Assembly Instructions

1. Cut tubing to desired length.
2. Slide nut and then sleeve on tubing. Threaded end of nut "A" must face toward fitting body.
3. Insert tubing into the preassembled fitting. Be sure tubing is bottomed in fitting.
4. Tighten nut to required torque as indicated on chart. Another check on proper assembly is dimension A also noted on chart. A gauge ring also assures installation to specification. See page 96.

Tube Size	Torque	A Dimension
1/4	85 to 115 in. lbs.	.085/.105
3/8	12 to 17 ft. lbs.	.125/.145
1/2	25 to 33 ft. lbs.	.100/.120
5/8	26 to 35 ft. lbs.	.115/.135
3/4	38 to 50 ft. lbs.	.180/.200

Disassembly: Remove nut and pull tubing out of fitting body. Insert will remain in tubing.

Reassembly: Push tubing and insert into fitting body until it bottoms. Thread nut onto fitting body and torque as in Step 4.

Label Set: **FS-900** (adhesive)
CL-16-3 (non-adhesive)

Use with Weatherhead NT100 Air Brake Tubing (SAE J844), see page 33.

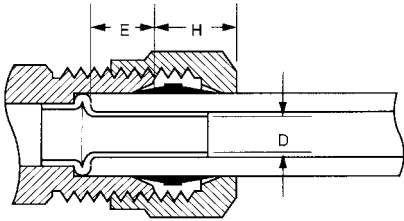

Tube O.D.	E Tube Stop	H*	D
1/4	.20	.32	.133
3/8	.26	.42	.215
1/2	.39	.45	.340
5/8	.39	.48	.398
3/4	.51	.50	.523

*NOTE: H is hand tight dimensions.

Sleeve
(Ref. SAE No. 100115)

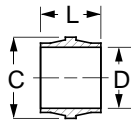

Tube O.D.	Catalog Number	Dia. C	D	L
1/4	1460x4	.359	.256	.30
3/8	1460x6	.479	.384	.39
1/2	1460x8	.625	.509	.43
5/8	1460x10	.745	.635	.48
3/4	1460x12	.922	.760	.53

Nut
(Ref. SAE No. 100110)

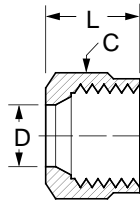
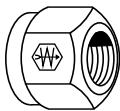

Tube O.D.	Catalog Number	Hex C	D	L
1/4	1461x4	9/16	.256	.45
3/8	1461x6	5/8	.384	.63
1/2	1461x8	13/16	.509	.72
5/8	1461x10	15/16	.634	.77
3/4	1461x12	1-1/8	.760	.81

Union
(Ref. SAE No. 100101BA)

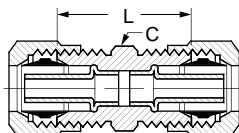
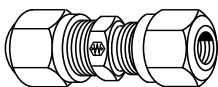

Tube O.D.	Catalog Number	Hex C	L
1/4	1462x4	7/16	.85
3/8	1462x6	9/16	1.10
1/2	1462x8	11/16	1.31
5/8	1462x10	13/16	1.43
3/4	1462x12	1	1.60

Air Brake - Nylon Tubing

**Brass
Fittings**

Use with Weatherhead NT100 Air Brake Tubing (SAE J844), see page 33.

Male Connector (Ref. SAE No. 100102BA)

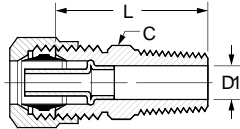
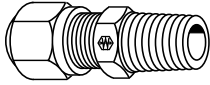

Tube O.D.	Male Pipe Thread	Catalog Number	Hex C	D1	L
1/4	1/16	1468x4x1	7/16	.125	.90
1/4	1/8	1468x4	7/16	.188	.88
1/4	1/4	1468x4x4	9/16	.188	1.09
1/4	3/8	1468x4x6	11/16	.188	1.12
3/8	1/8	1468x6x2	9/16	.188	1.02
3/8	1/4	1468x6	9/16	.312	1.20
3/8	3/8	1468x6x6	11/16	.312	1.23
3/8	1/2	1468x6x8	7/8	.312	1.42
1/2	1/4	1468x8x4	11/16	.312	1.32
1/2	3/8	1468x8	11/16	.406	1.32
1/2	1/2	1468x8x8	7/8	.406	1.51
1/2	3/4	1468x8x12	1-1/16	.406	1.57
5/8	3/8	1468x10x6	13/16	.406	1.38
5/8	1/2	1468x10	7/8	.531	1.57
5/8	3/4	1468x10x12	1-1/16	.750	1.63
3/4	1/2	1468x12	1	.531	1.67
3/4	3/4	1468x12x12	1-1/16	.660	1.70

Female Connector (Ref. SAE No. 100103BA)

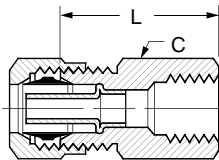
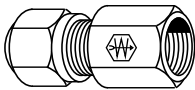

Tube O.D.	Fem. Pipe Thread	Catalog Number	Hex C	L
1/4	1/8	1466x4	9/16	.85
3/8	1/8	1466x6x2♦	9/16	1.01
3/8	1/4	1466x6	11/16	1.19
3/8	3/8	1466x6x6	7/8	1.19
1/2	3/8	1466x8	7/8	1.28

Bulkhead Union

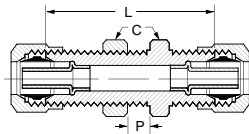
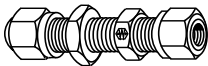

Tube O.D.	Catalog Number	Hex C	L	Max. P
1/4	1474x4	9/16	1.38	.25
3/8	1474x6	11/16	1.62	.25
1/2	1474x8♦	13/16	1.88	.25
5/8	1474x10♦	15/16	2.09	.25

45° Male Elbow (Ref. SAE No. 100302BA)

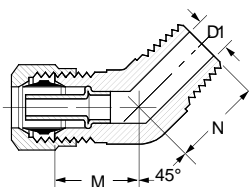
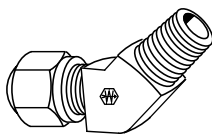

Tube O.D.	Male Pipe Thread	Catalog Number	D1	M	N
1/4	1/8	1480x4	.188	.50	.64
1/4	1/4	1480x4x4	.312	.61	.86
3/8	1/4	1480x6	.312	.72	.86
3/8	3/8	1480x6x6	.406	.76	.95
1/2	1/4	1480x8x4	.312	.85	.95
1/2	3/8	1480x8	.406	.85	.95
1/2	1/2	1480x8x8	.531	.88	1.17
5/8	1/2	1480x10	.531	.94	1.17

♦MTO - Made To Order

B
R
A
S
S

Use with Weatherhead NT100 Air Brake Tubing (SAE J844), see page 33.

Union Elbow
(Ref. SAE No. 100201BA)

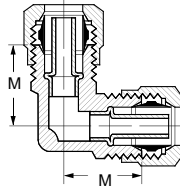
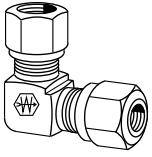

Tube O.D.	Catalog Number	M
1/4	1465x4♦	.63
3/8	1465x6♦	.80
1/2	1465x8♦	.94
5/8	1465x10♦	1.10

90° Male Elbow
(Ref. SAE No. 100202BA)

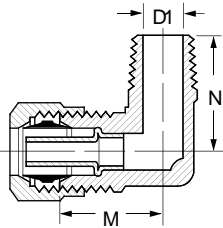
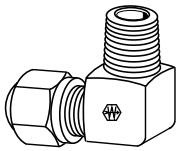

Tube O.D.	Male Pipe Thread	Catalog Number	D1	M	N
1/4	1/8	1469x4	.188	.63	.67
1/4	1/4	1469x4x4	.312	.69	.88
1/4	3/8	1469x4x6	.406	.74	.87
3/8	1/8	1469x6x2	.188	.73	.75
3/8	1/4	1469x6	.312	.80	.93
3/8	3/8	1469x6x6	.406	.85	.92
3/8	1/2	1469x6x8	.531	.95	1.11
1/2	1/4	1469x8x4	.312	.87	1.00
1/2	3/8	1469x8	.406	.94	1.00
1/2	1/2	1469x8x8	.531	1.04	1.19
5/8	3/8	1469x10x6	.406	1.01	1.06
5/8	1/2	1469x10	.531	1.10	1.25
5/8	3/4	1469x10x12	.750	1.21	1.25
3/4	1/2	1469x12	.531	1.20	1.34

90° Male Elbow - Long
(Ref. SAE No. 100202BA)

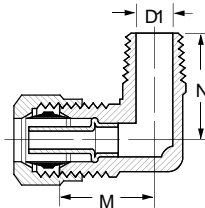
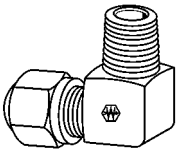

Tube O.D.	Male Pipe Thread	Catalog Number	D1	M	N
3/8	1/4	1469x6L	.312	.80	1.44
1/2	3/8	1469x8L	.406	.94	1.38

90° Female Elbow
(Ref. SAE No. 100203BA)

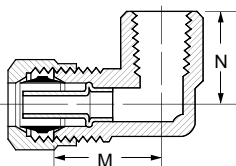
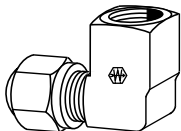

Tube O.D.	Fem. Pipe Thread	Catalog Number	M	N
1/4	1/8	1470x4	.70	.54
3/8	1/4	1470x6♦	.90	.78
3/8	3/8	1470x6x6♦	.95	.78
1/2	3/8	1470x8♦	1.04	.83
1/2	1/2	1470x8x8♦	1.14	1.02
5/8	1/2	1470x10x10x8♦	1.15	1.08

Air Brake – Nylon Tubing

**Brass
Fittings**

Use with Weatherhead NT100 Air Brake Tubing (SAE J844), see page 33.

Union Tee (Ref. SAE No. 100401BA)

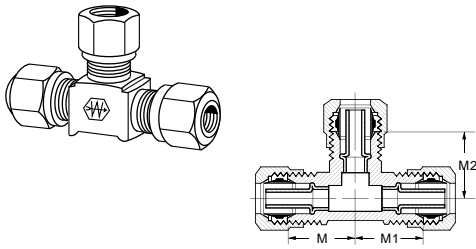

NOTE: Dimensions read left, right, center.

Tube O.D.	Catalog Number	M	M1	M2
1/4	1464x4	.63	.63	.63
1/4x3/8x3/8	1464x4x6x6♦	.70	.80	.80
3/8x3/8x1/4	1464x6x6x4	.72	.72	.69
3/8	1464x6	.80	.80	.80
1/2x1/2x3/8	1464x8x8x6	.86	.86	.85
1/2	1464x8	.94	.94	.94

Male Branch Tee (Ref. SAE No. 100425BA)

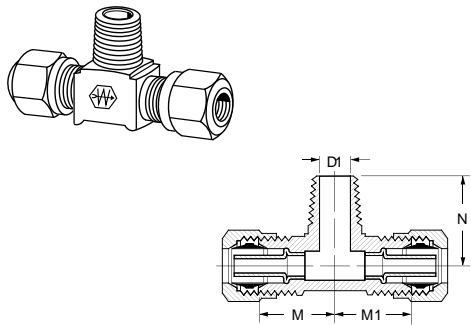

Tube O.D.	Male Pipe Thread	Catalog Number	D1	M	M1	N
1/4	1/8	1472x4	.188	.63	.63	.67
3/8x1/4	1/4	1472x6x4x4	.312	.80	.69	.93
3/8	1/8	1472x6x6x2♦	.188	.73	.73	.75
3/8	1/4	1472x6	.312	.80	.80	.93
3/8	3/8	1472x6x6x6	.406	.85	.85	.92
1/2x3/8	3/8	1472x8x6x6	.406	.94	.85	1.00
1/2	1/4	1472x8x8x4	.312	.87	.87	1.00
1/2	3/8	1472x8	.406	.94	.94	1.00
5/8	1/4	1472x10x10x4♦	.312	1.13	1.13	1.12

Female Branch Tee

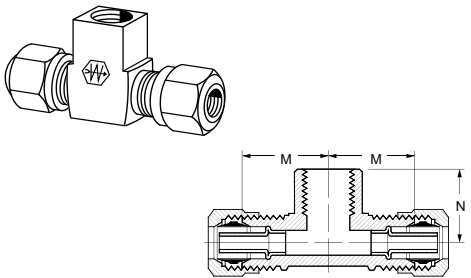

Tube O.D.	Fem. Pipe Thread	Catalog Number	M	N
3/8	1/4	1477x6	.90	.78
1/2	1/4	1477x8x8x4♦	.97	.83
5/8	1/4	1477x10x10x4	1.04	.89

Male Run Tee (Ref. SAE No. 100424BA)

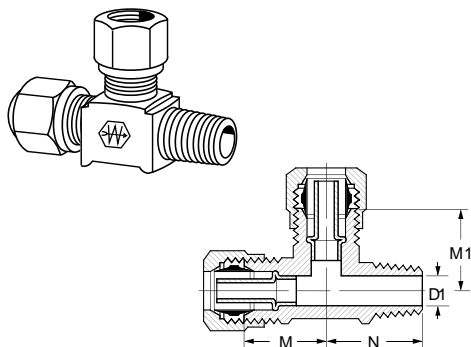

Tube O.D.	Male Pipe Thread	Catalog Number	D1	M	M1	N
1/4	1/8	1471x4	.188	.64	.64	.67
3/8x1/4	1/4	1471x6x4x4	.312	.72	.69	.88
3/8	1/4	1471x6	.312	.80	.80	.93
3/8	3/8	1471x6x6x6	.406	.85	.85	.92
1/2	3/8	1471x8♦	.406	.94	.94	1.10

♦MTO - Made To Order

B
R
A
S
S

Use with Weatherhead NT100 Air Brake Tubing (SAE J844), see page 33.

Adapter Tee

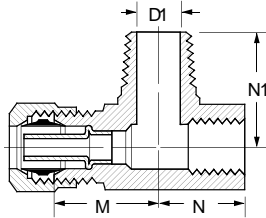
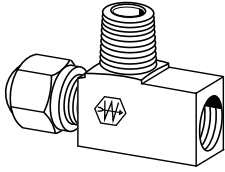

Tube O.D.	Fem. Pipe Thread	Male Pipe Thread	Catalog Number	D1	M	N	N1
3/8	1/4	1/4	1482x6x4x4*	.312	.88	.75	.94
3/8	1/4	3/8	1482x6x4x6*	.402	.94	.75	1.00

Insert (Brass)

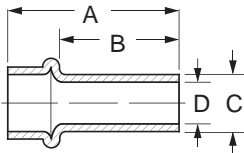
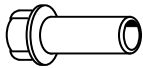

Tube O.D.	Catalog Number	A	B	C	D
1/4	1484x4	.64	.46	.163	.133
3/8	1484x6	.76	.58	.245	.215
1/2	1484x8	.94	.76	.370	.340
5/8	1484x10	1.06	.84	.434	.398
3/4	1484x12	1.21	1.00	.559	.523

Gauge Ring

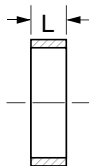

Tube O.D.	Catalog Number	L
1/4	1485x4	.085/.105
3/8	1485x6	.125/.145
1/2	1485x8	.100/.120
5/8	1485x10	.115/.135
3/4	1485x12	.180/.200

NOTE: Nut screwed to Gauge Ring assures installation to specifications.

Air Brake - Copper Tubing

Brass
Fittings

 Refer to safety information regarding tubing selection on page 1.

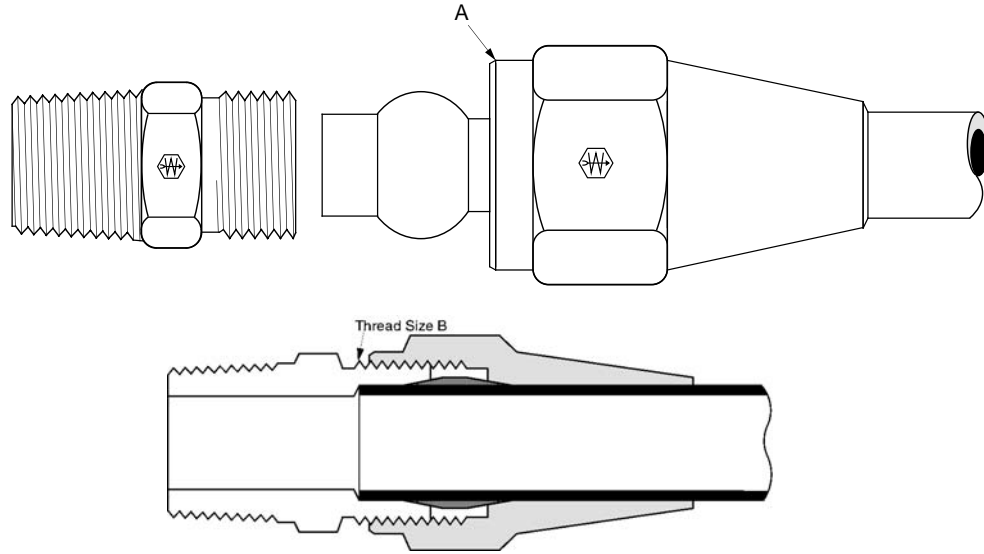

Tube O.D.	1/4	3/8	1/2	5/8	3/4	1
Thread Size-B	7/16-24	17/32-24	11/16-20	13/16-18	1-18	1-1/4-16

• **Typical Application**

Air brake systems.

• **Pressure**

Maximum operating pressure of 150 psi.

• **Vibration**

Fair resistance.

• **Temperature Range**

-65°F to +250°F (-53°C to +121°C) with copper tubing.

• **Material**

CA360 Brass.

• **Used With**

Copper tubing in air brake systems.

• **Advantages**

Easy to assemble (no flaring). May be used with nylon tubing by replacing long nut and spherical sleeve with insert, rigid sleeve and nut. See page 91 for details.

• **Conformance**

Meets specifications and standards of SAE and DOT.

• **How to Order**

For complete assemblies (body, nuts and sleeves), order by catalog number. Example: 1368x4. To order body only (less nut and sleeve), add prefix "B" to catalog number. Example: B1368x4. Nuts and sleeve can be ordered separately by catalog number.

To order complete assembly with pipe sealant (Seal-A-Thread), add suffix "Z" to catalog number. Example: 1368x4Z (special order only).

• **NOTE**

Refer to current price list for availability of cataloged items. Quotations and delivery of non-stock items supplied on request. Configurations and dimensions subject to change without notice. Additional information can be found in SAE J246.

• **Assembly Instructions**

1. Cut tubing to desired length. Make sure all burrs are removed and the ends are cut square.
2. Slide nut and then sleeve on tubing. Threaded end of nut "A" must face toward fitting body.
3. Insert tubing into fitting. Be sure tubing is bottomed on fitting shoulder.
4. Thread nut onto fitting body until it is hand tight.
5. From that point, tighten with a wrench the number of turns indicated in the chart below.

Tube Size	Additional Number of Turns from Hand Tight
1/4, 3/8	1-3/4
1/2, 5/8, 3/4	3-1/4

Label Set: **FS-800** (adhesive)
CL-491 (non-adhesive)

B
R
A
S
S

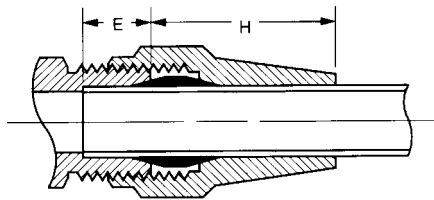

NOTE: H is hand tight dimensions.

Tube O.D.	E Tube Depth	H
1/4	.25	.58
3/8	.31	.87
1/2	.44	.95
5/8	.44	1.05
3/4	.56	1.25

Sleeve (Ref. SAE No. 120115)

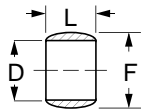

Tube O.D.	Catalog Number	D	F	L
1/4	1360x4	.255	.322	.250
3/8	1360x6	.382	.461	.313
1/2	1360x8	.507	.594	.375
5/8	1360x10	.632	.734	.438
3/4	1360x12	.758	.874	.500

Nut (Ref. SAE No. 120111)

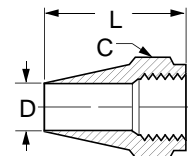
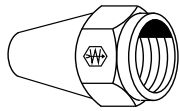

*Compressor Nut with V groove Hex.

Tube O.D.	Catalog Number	Hex C	D	L
1/4	1361x4	9/16	.256	.75
3/8	1361x6	5/8	.384	1.13
1/2	1361x8	13/16	.509	1.25
5/8	1361x10	15/16	.634	1.38
5/8	1361x10V*	1	.634	1.38
3/4	1361x12	1-1/8	.760	1.56

Union (Ref. SAE No. 120101BA)

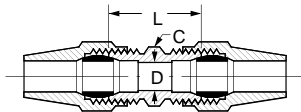

Tube O.D.	Catalog Number	Hex C	D	L
1/4	1362x4	7/16	.188	.85
3/8	1362x6	9/16	.312	1.10
1/2	1362x8	11/16	.406	1.31
5/8	1362x10	13/16	.531	1.43
3/4	1362x12	1	.656	1.60
1	1362x16	1-1/4	.875	1.78

Male Connector (Ref. SAE No. 120102BA)

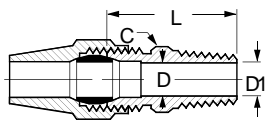
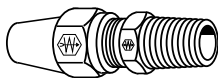

Tube O.D.	Male Pipe Thread	Catalog Number	Hex C	D	D1	L
1/4	1/8	1368x4	7/16	.188	.188	.88
1/4	1/4	1368x4x4	9/16	.188	.188	1.09
3/8	1/8	1368x6x2	9/16	.312	.188	1.02
3/8	1/4	1368x6	9/16	.312	.312	1.20
3/8	3/8	1368x6x6	11/16	.312	.406 opt.	1.23
3/8	1/2	1368x6x8	7/8	.312	.531 opt.	1.42
1/2	1/4	1368x8x4	11/16	.406	.312	1.32
1/2	3/8	1368x8	11/16	.406	.406	1.32
1/2	1/2	1368x8x8	7/8	.406	.531 opt.	1.51
5/8	3/8	1368x10x6	13/16	.531	.406	1.38
5/8	1/2	1368x10	7/8	.531	.531	1.57
3/4	1/2	1368x12	1	.656	.531	1.67
3/4	3/4	1368x12x12	1-1/16	.656	.719 opt.	1.70

Air Brake - Copper Tubing

**Brass
Fittings**

Female Connector (Ref. SAE No. 120103BA)

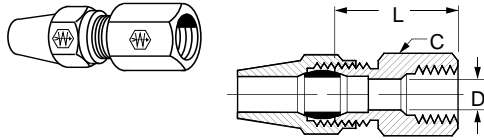

Tube O.D.	Fem. Pipe Thread	Catalog Number	Hex C	D	L
3/8	1/4	1366x6	11/16	.312	1.19
3/8	3/8	1366x6x6	7/8	.312	1.19
1/2	3/8	1366x8	7/8	.406	1.28

45° Male Elbow (Ref. SAE No. 120302BA)

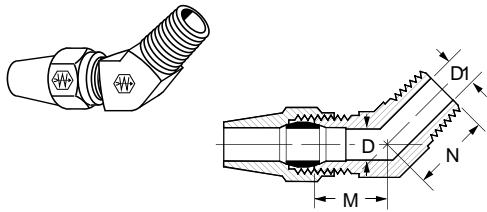

Tube O.D.	Male Pipe Thread	Catalog Number	D	D1	M	N
3/8	1/4	1380x6	.312	.312	.72	.86
3/8	3/8	1380x6x6	.312	.406	.76	.95
1/2	3/8	1380x8	.406	.406	.85	.95
5/8	1/2	1380x10	.531	.531	.94	1.17

Union Elbow (Ref. SAE No. 120201BA)

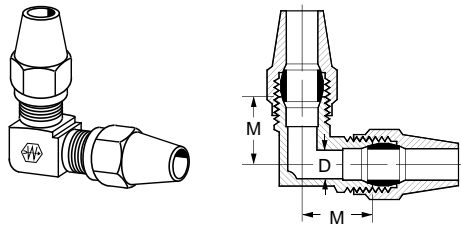

Tube O.D.	Catalog Number	M	D
3/8	1365x6♦	.80	.312
1/2	1365x8♦	.94	.406
5/8	1365x10♦	1.10	.531

90° Male Elbow (Ref. SAE No. 120202BA)

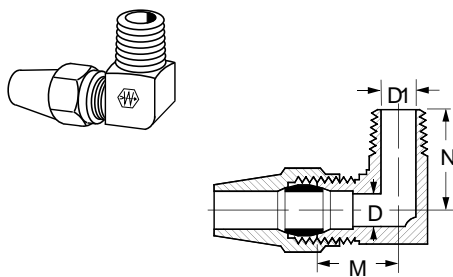

Tube O.D.	Male Pipe Thread	Catalog Number	D	D1	M	N
1/4	1/8	1369x4	.188	.188	.63	.67
1/4	1/4	1369x4x4	.188	.312	.69	.88
3/8	1/8	1369x6x2	.312	.188	.73	.75
3/8	1/4	1369x6	.312	.312	.80	.93
3/8	3/8	1369x6x6	.312	.406	.85	.92
3/8	1/2	1369x6x8	.312	.531	.95	1.11
1/2	1/4	1369x8x4	.406	.312	.87	1.00
1/2	3/8	1369x8	.406	.406	.94	1.00
1/2	1/2	1369x8x8	.406	.531	1.04	1.19
5/8	3/8	1369x10x6	.531	.406	1.01	1.06
5/8	1/2	1369x10	.531	.531	1.10	1.25

90° Male Elbow - Long

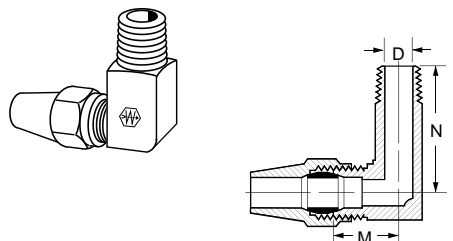

Tube O.D.	Male Pipe Thread	Catalog Number	D	M	N
3/8	1/8	1369x6x2L♦	.188	.75	1.88
3/8	1/4	1369x6L	.312	.81	1.44
1/2	3/8	1369x8L	.406	1.25	1.38
3/4	1/2	1369x12L♦	.531	1.31	1.81

♦MTO - Made To Order

B
R
A
S
S

90° Female Elbow
(Ref. SAE No. 120203BA)

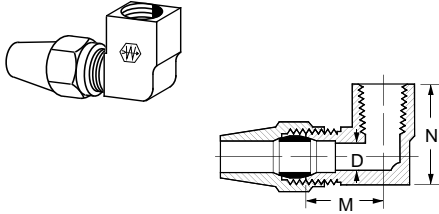

Tube O.D.	Fem. Pipe Thread	Catalog Number	D	M	N
1/2	3/8	1370x8♦	.406	1.04	.83

Union Tee
(Ref. SAE No. 120401BA)

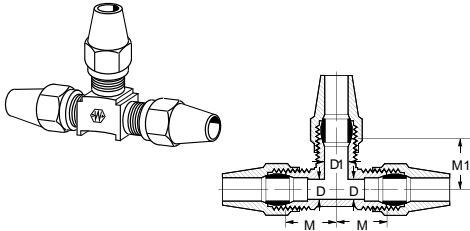

Tube O.D.	Catalog Number	M	M1	D	D1
3/8	1364x6	.80	.80	.312	.312
3/8x3/8x1/2	1364x6x6x8♦	.86	.86	.312	.406
1/2	1364x8	.94	.94	.406	.406

Male Run Tee
(Ref. SAE No. 120424BA)

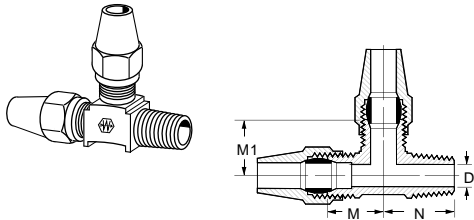

Tube O.D.	Male Pipe Thread	Catalog Number	D	M	M1	N
3/8	1/4	1371x6	.312	.80	.80	.93
3/8	3/8	1371x6x6x6	.406	.85	.85	.92
1/2	3/8	1371x8♦	.406	.94	.94	1.00

Male Branch Tee
(Ref. SAE No. 120425BA)

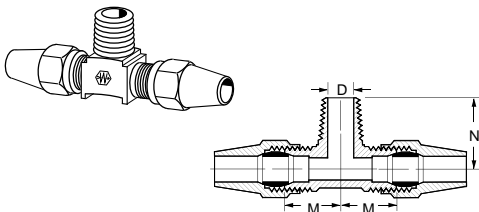

Tube O.D. A	Tube O.D. B	Male Pipe Thread	Catalog Number	D	M	N
3/8	3/8	1/8	1372x6x6x2♦	.188	.73	.75
3/8	3/8	1/4	1372x6	.312	.80	.93
3/8	3/8	3/8	1372x6x6x6	.406	.85	.92
1/2	1/2	3/8	1372x8	.406	.94	1.00
5/8	1/2	1/2	1372x10x8x8♦	.530	1.120	1.060

Adapter Tee

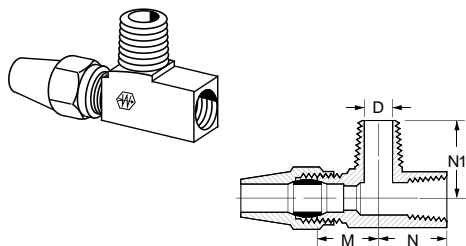

Tube O.D.	M&F Pipe Thread	Catalog Number	D	M	N	N1
3/8	1/4	1382x6x4x4♦	.312	.88	.75	.94

♦MTO - Made To Order

Air Brake – Copper Tubing

**Brass
Fittings**

Bulkhead Coupling (Brass)

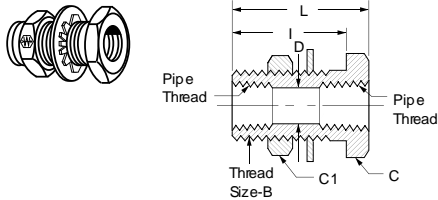

Fem. Pipe Thread	Catalog Thread	Thread Size B	Hex C	Hex C1	D	I	L
1/4	1344	3/4-16	1	15/16	.422	1.25	1.50
1/4	1345	3/4-16	1	15/16	.422	.69	.94
3/8	1346	1-14	1-1/8	1-3/8	.563	1.06	1.31
1/2	1351	1-1/8-14	1-1/4	1-3/8	.703	1.19	1.50

Bulkhead Coupling (Brass)

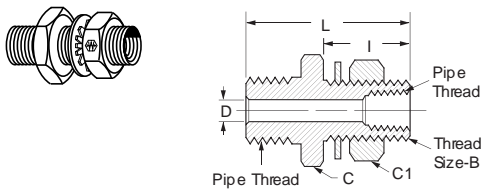

Male Pipe Thread	Fem. Pipe Thread	Catalog Number	Thread Size B	Hex C	Hex C1	D	I	L
1/2	1/4	1340	3/4-16	1-1/4	15/16	.312	1.13	2.16
1/2	1/4	1341	3/4-16	1-1/4	15/16	.312	1.53	2.53

Bulkhead Coupling (Brass)

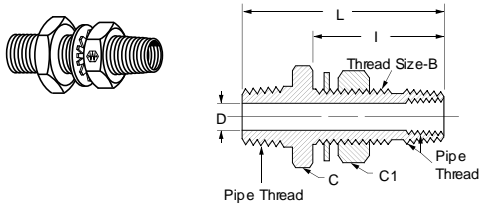

Male Pipe Thread	Fem. Pipe Thread	Catalog Number	Thread Size B	Hex C	Hex C1	D	I	L
1/2	1/4	1342	1-14	1-1/4	1-3/8	.375	1.88	2.94
1/2	1/4	1343	1-14	1-1/4	1-3/8	.375	2.88	3.94

Draincock

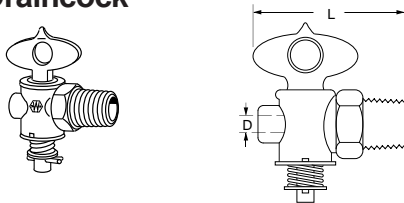

Male Pipe Thread	Catalog Number	D	L
1/4	W15310	.188	1.56

Shut Off Valve

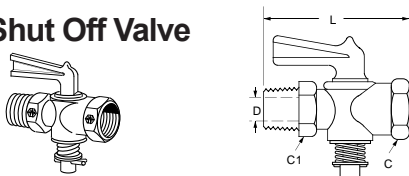

Rating: 125 psi with one 1/4" bubble in 5 seconds permissible key leakage.

Male Pipe Thread	Fem. Pipe Thread	Catalog Number	Hex C	Hex C1	D	L
1/4	1/4	W20332	5/8	3/4	.218	1.81

External Seat Draincock

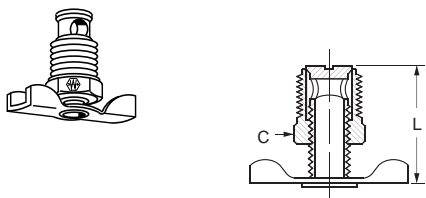

Male Pipe Thread	Catalog Number	Hex C	L
1/4	145	9/16	1.00

BRASS

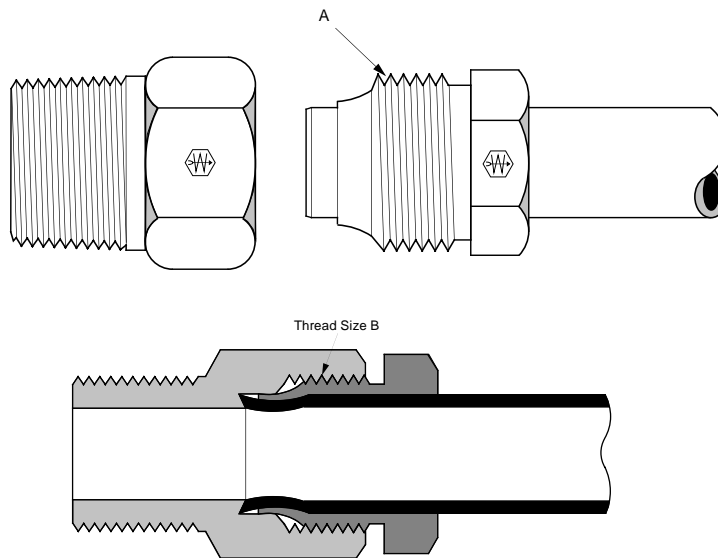

Tube O.D.	1/8	3/16	1/4	5/16	3/8
Thread Size-B	5/16-24	3/8-24	7/16-24	1/2-20	9/16-20

• **Typical Application**

Oil, air, water and lubrication systems.

• **Pressure**

Operating pressure of 500 psi for 1/8" to 1/4" sizes, 250 psi for 5/16" and 3/8" sizes.

• **Vibration**

Fair resistance.

• **Temperature Range**

-65°F to +250°F (-53°C to +121°C) range at maximum operating pressures.

• **Material**

CA360 Brass.

• **Used With**

Aluminum and copper tubing. Not recommended for steel tubing.

• **Advantages**

Easy to assemble, no flaring. Two (2) piece construction.

• **Conformance**

Meets ASA and ASME specifications.

• **How to Order**

Order individually by catalog number.

• **NOTE**

Refer to current price list for availability of cataloged items. Quotations and delivery of non-stock items supplied on request. Configurations and dimensions subject to change without notice.

• **Assembly Instructions**

1. Cut tubing to desired length.
2. Slide nut on end of tube. Threaded end "A" of nut must face toward fitting.
3. Insert tube into fitting body. Be sure tube is bottomed on fitting shoulder.
4. Lubricate threads and assemble nut to fitting body.
5. Tighten nut, hand tight. From hand tight, tighten with a wrench 1-1/2 additional turns to form proper seal.

Threaded Sleeve

**Brass
Fittings**

Nut

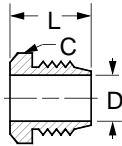
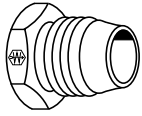

Tube O.D.	Catalog Number	Hex C	D	L
1/8	6100x2	3/8	.130	.50
3/16	6100x3	7/16	.193	.53
1/4	6100x4	1/2	.255	.56
3/8	6100x6♦	5/8	.380	.61

Male Connector

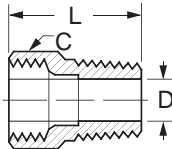
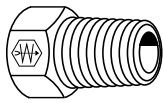

Tube O.D.	Male Pipe Thread	Catalog Number	Hex C	D	L
1/8	1/8	6200x2	7/16	.078	.62
1/8	*	6200x2x21	7/16	.080	.62
3/16	1/8	6200x3	7/16	.141	.69
1/4	1/8	6200x4	1/2	.188	.75
3/8	1/4	6200x6♦	5/8	.312	.97

*Thread Size 1/4-28 Tapered Male Thread

Union

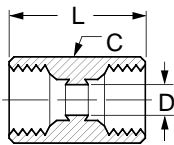
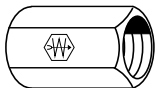

Tube O.D.	Catalog Number	Hex C	D	L
1/4	6300x4♦	1/2	.187	1.00

Male Elbow

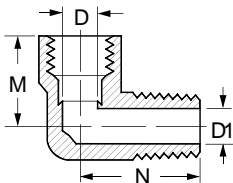
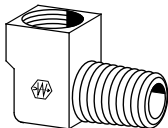

Tube O.D.	Male Pipe Thread	Catalog Number	D	D1	M	N
1/8	1/8	6400x2	.073	.125	.50	.66
1/8	*	6400x2x21	.078	.080	.50	.52
3/16	1/8	6400x3	.141	.156	.56	.62
1/4	1/8	6400x4	.188	.188	.52	.62

*Thread Size 1/4-28 Tapered Male Thread

♦MTO - Made To Order

B
R
A
S
S

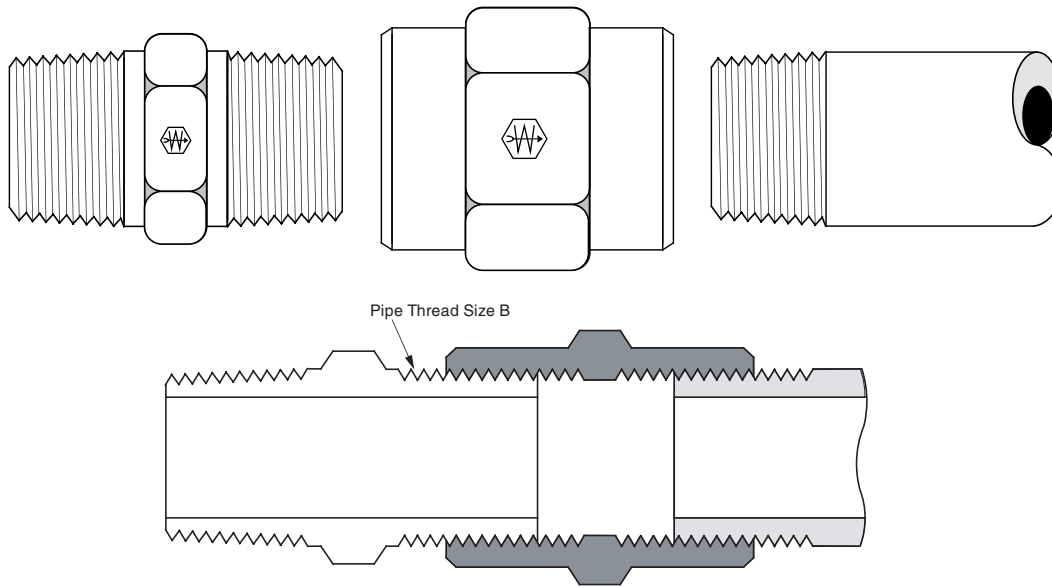

Pipe Size	1/16	1/8	1/4	3/8	1/2	3/4
Thread Size-B	1/16-27	1/8-27	1/4-18	3/8-18	1/2-14	3/4-14

• **Typical Application**

Grease, refrigeration, instrumentation and hydraulic systems. Fuel, LP and natural gas available on special order.

• **Pressure**

Operating pressure up to 1200 psi.

• **Vibration**

Fair resistance.

• **Temperature Range**

-65°F to +250°F (-53°C to +121°C).

• **Material**

CA360 Brass.

• **Used With**

Brass, bronze and iron pipe.

• **Advantages**

Dryseal pipe threads (NPTF). Large range of sizes and configurations

• **Conformance**

Listed by Underwriters Laboratories (available on special order) for fuel equipment, refrigeration and gas. Meets specifications and standards of ASA, ASME and SAE.

• **How to Order**

Order individually by catalog number. Example: 3325x4. To order with pipe sealant (Seal-A-Thread), add a "Z" suffix to the catalog number. (Special order only). Example: 3325x4Z.



• **NOTE**

Refer to current price list for availability of cataloged items. Quotations and delivery of non-stock items supplied on request. Configurations and dimensions subject to change without notice. Additional information can be found in SAE J530 Automotive Pipe Fittings and SAE J531 Drain Plugs.

• **Assembly Instructions**

1. Tighten approximately 2-1/2 turns past hand tight.
2. Fittings with Seal-A-Thread tighten two turns past hand tight. Brittle materials require special cautions.

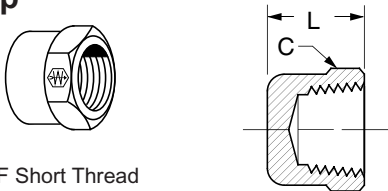
- **Label Set:** **W-8022** (adhesive)
CL-490 (non-adhesive)

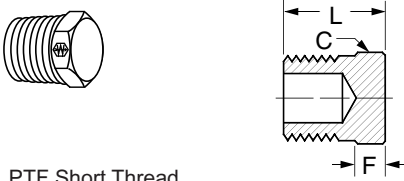
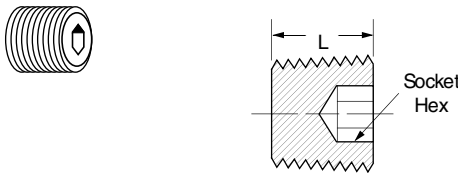
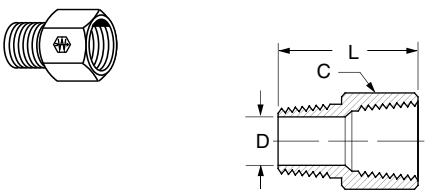
<p>Cap</p>  <p>*PTF Short Thread</p>	<table border="1"> <thead> <tr> <th>Fem. Pipe Thread</th> <th>Catalog Number</th> <th>Hex C</th> <th>L</th> </tr> </thead> <tbody> <tr> <td>1/8*</td> <td>3129x2</td> <td>9/16</td> <td>.50</td> </tr> <tr> <td>1/4*</td> <td>3129x4</td> <td>11/16</td> <td>.59</td> </tr> <tr> <td>3/8*</td> <td>3129x6</td> <td>13/16</td> <td>.68</td> </tr> </tbody> </table>	Fem. Pipe Thread	Catalog Number	Hex C	L	1/8*	3129x2	9/16	.50	1/4*	3129x4	11/16	.59	3/8*	3129x6	13/16	.68																																						
Fem. Pipe Thread	Catalog Number	Hex C	L																																																				
1/8*	3129x2	9/16	.50																																																				
1/4*	3129x4	11/16	.59																																																				
3/8*	3129x6	13/16	.68																																																				
<p>Slotted Plug</p>  <p>*PTF Short Thread</p>	<table border="1"> <thead> <tr> <th>Male Pipe Thread</th> <th>Catalog Number</th> <th>E</th> <th>L</th> </tr> </thead> <tbody> <tr> <td>1/8*</td> <td>3150x2</td> <td>.05</td> <td>.28</td> </tr> <tr> <td>1/4*</td> <td>3150x4</td> <td>.08</td> <td>.42</td> </tr> <tr> <td>3/8*</td> <td>3150x6</td> <td>.09</td> <td>.43</td> </tr> </tbody> </table>	Male Pipe Thread	Catalog Number	E	L	1/8*	3150x2	.05	.28	1/4*	3150x4	.08	.42	3/8*	3150x6	.09	.43																																						
Male Pipe Thread	Catalog Number	E	L																																																				
1/8*	3150x2	.05	.28																																																				
1/4*	3150x4	.08	.42																																																				
3/8*	3150x6	.09	.43																																																				
<p>Square Head Plug</p>  <p>*PTF Short Thread</p>	<table border="1"> <thead> <tr> <th>Male Pipe Thread</th> <th>Catalog Number</th> <th>Square C</th> <th>F</th> <th>L</th> </tr> </thead> <tbody> <tr> <td>1/8*</td> <td>3151x2</td> <td>.28</td> <td>.24</td> <td>.58</td> </tr> <tr> <td>1/4*</td> <td>3151x4</td> <td>.37</td> <td>.29</td> <td>.74</td> </tr> <tr> <td>3/8*</td> <td>3151x6</td> <td>.43</td> <td>.32</td> <td>.82</td> </tr> <tr> <td>1/2*</td> <td>3151x8</td> <td>.56</td> <td>.39</td> <td>.99</td> </tr> <tr> <td>3/4*</td> <td>3151x12</td> <td>.62</td> <td>.43</td> <td>1.12</td> </tr> </tbody> </table>	Male Pipe Thread	Catalog Number	Square C	F	L	1/8*	3151x2	.28	.24	.58	1/4*	3151x4	.37	.29	.74	3/8*	3151x6	.43	.32	.82	1/2*	3151x8	.56	.39	.99	3/4*	3151x12	.62	.43	1.12																								
Male Pipe Thread	Catalog Number	Square C	F	L																																																			
1/8*	3151x2	.28	.24	.58																																																			
1/4*	3151x4	.37	.29	.74																																																			
3/8*	3151x6	.43	.32	.82																																																			
1/2*	3151x8	.56	.39	.99																																																			
3/4*	3151x12	.62	.43	1.12																																																			
<p>Hex Head Plug</p>  <p>* PTF Short Thread ** PTF Special Short Thread</p>	<table border="1"> <thead> <tr> <th>Male Pipe Thread</th> <th>Catalog Number</th> <th>Hex C</th> <th>F</th> <th>L</th> </tr> </thead> <tbody> <tr> <td>1/8*</td> <td>3152x2</td> <td>7/16</td> <td>.19</td> <td>.57</td> </tr> <tr> <td>1/4*</td> <td>3152x4</td> <td>9/16</td> <td>.18</td> <td>.62</td> </tr> <tr> <td>3/8*</td> <td>3152x6</td> <td>11/16</td> <td>.22</td> <td>.72</td> </tr> <tr> <td>1/2*</td> <td>3152x8</td> <td>7/8</td> <td>.22</td> <td>.78</td> </tr> <tr> <td>3/4**</td> <td>3152x12</td> <td>1-1/16</td> <td>.25</td> <td>.88</td> </tr> </tbody> </table>	Male Pipe Thread	Catalog Number	Hex C	F	L	1/8*	3152x2	7/16	.19	.57	1/4*	3152x4	9/16	.18	.62	3/8*	3152x6	11/16	.22	.72	1/2*	3152x8	7/8	.22	.78	3/4**	3152x12	1-1/16	.25	.88																								
Male Pipe Thread	Catalog Number	Hex C	F	L																																																			
1/8*	3152x2	7/16	.19	.57																																																			
1/4*	3152x4	9/16	.18	.62																																																			
3/8*	3152x6	11/16	.22	.72																																																			
1/2*	3152x8	7/8	.22	.78																																																			
3/4**	3152x12	1-1/16	.25	.88																																																			
<p>Hex Socket Plug</p> 	<table border="1"> <thead> <tr> <th>Male Pipe Thread</th> <th>Catalog Number</th> <th>Socket Hex</th> <th>L</th> </tr> </thead> <tbody> <tr> <td>1/8</td> <td>3153x2</td> <td>3/16</td> <td>.270</td> </tr> <tr> <td>1/4</td> <td>3153x4♦</td> <td>1/4</td> <td>.410</td> </tr> <tr> <td>3/8</td> <td>3153x6♦</td> <td>5/16</td> <td>.410</td> </tr> <tr> <td>1/2</td> <td>3153x8♦</td> <td>3/8</td> <td>.540</td> </tr> </tbody> </table>	Male Pipe Thread	Catalog Number	Socket Hex	L	1/8	3153x2	3/16	.270	1/4	3153x4♦	1/4	.410	3/8	3153x6♦	5/16	.410	1/2	3153x8♦	3/8	.540																																		
Male Pipe Thread	Catalog Number	Socket Hex	L																																																				
1/8	3153x2	3/16	.270																																																				
1/4	3153x4♦	1/4	.410																																																				
3/8	3153x6♦	5/16	.410																																																				
1/2	3153x8♦	3/8	.540																																																				
<p>Adapter (Ref. SAE No. 130139)</p> 	<table border="1"> <thead> <tr> <th>Fem. Pipe Thread</th> <th>Male Pipe Thread</th> <th>Catalog Number</th> <th>Hex C</th> <th>D</th> <th>L</th> </tr> </thead> <tbody> <tr> <td>1/8</td> <td>1/8</td> <td>3200x2</td> <td>9/16</td> <td>.219</td> <td>.88</td> </tr> <tr> <td>1/4</td> <td>1/8</td> <td>3200x4x2</td> <td>3/4</td> <td>.219</td> <td>1.06</td> </tr> <tr> <td>1/4</td> <td>1/4</td> <td>3200x4</td> <td>3/4</td> <td>.312</td> <td>1.25</td> </tr> <tr> <td>3/8</td> <td>1/4</td> <td>3200x6x4</td> <td>7/8</td> <td>.312</td> <td>1.25</td> </tr> <tr> <td>3/8</td> <td>3/8</td> <td>3200x6</td> <td>7/8</td> <td>.438</td> <td>1.25</td> </tr> <tr> <td>1/2</td> <td>3/8</td> <td>3200x8x6</td> <td>1-1/16</td> <td>.438</td> <td>1.47</td> </tr> <tr> <td>3/4</td> <td>3/8</td> <td>3200x12x6</td> <td>1-1/4</td> <td>.438</td> <td>1.59</td> </tr> <tr> <td>3/4</td> <td>1/2</td> <td>3200x12x8</td> <td>1-1/4</td> <td>.562</td> <td>1.69</td> </tr> </tbody> </table>	Fem. Pipe Thread	Male Pipe Thread	Catalog Number	Hex C	D	L	1/8	1/8	3200x2	9/16	.219	.88	1/4	1/8	3200x4x2	3/4	.219	1.06	1/4	1/4	3200x4	3/4	.312	1.25	3/8	1/4	3200x6x4	7/8	.312	1.25	3/8	3/8	3200x6	7/8	.438	1.25	1/2	3/8	3200x8x6	1-1/16	.438	1.47	3/4	3/8	3200x12x6	1-1/4	.438	1.59	3/4	1/2	3200x12x8	1-1/4	.562	1.69
Fem. Pipe Thread	Male Pipe Thread	Catalog Number	Hex C	D	L																																																		
1/8	1/8	3200x2	9/16	.219	.88																																																		
1/4	1/8	3200x4x2	3/4	.219	1.06																																																		
1/4	1/4	3200x4	3/4	.312	1.25																																																		
3/8	1/4	3200x6x4	7/8	.312	1.25																																																		
3/8	3/8	3200x6	7/8	.438	1.25																																																		
1/2	3/8	3200x8x6	1-1/16	.438	1.47																																																		
3/4	3/8	3200x12x6	1-1/4	.438	1.59																																																		
3/4	1/2	3200x12x8	1-1/4	.562	1.69																																																		

♦MTO - Made To Order

Bushing (Ref. SAE No. 130140)

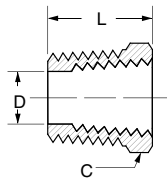
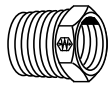

*PTF Short Thread
**Optional Counterbore

Male Pipe Thread	Fem. Pipe Thread	Catalog Number	Hex C	D	L
1/4*	1/8	3220x4x2	5/8	.339	.59
3/8	1/8	3220x6x2	11/16	.328	.75
3/8*	1/4	3220x6x4	11/16	.438	.69
1/2*	1/8	3220x8x2	7/8	.530**	.75
1/2*	1/4	3220x8x4	7/8	.438**	.75
1/2*	3/8	3220x8x6	7/8	.562	.75
3/4*	3/8	3220x12x6	1-1/8	.562	.88
3/4*	1/2	3220x12x8	1-1/8	.703	.88

Union

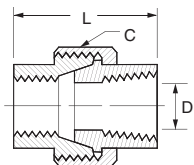
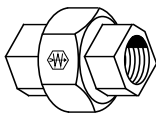

*PTF Short Thread

Fem. Pipe Thread	Catalog Number	Hex C	D	L
1/8*	3250x2♦	7/8	.339	.97
1/4*	3250x4	1-1/16	.438	1.31
3/8	3250x6♦	1-5/16	.560	1.66
1/2	3250x8	1-9/16	.703	1.81

Coupling (Ref. SAE No. 130138)

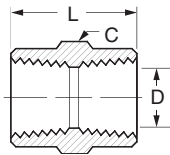
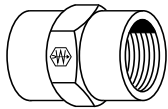

Fem. Pipe Thread	Catalog Number	Hex C	D	L
1/16	3300x1	7/16	.339	.75
1/8	3300x2	9/16	.339	.75
1/4	3300x4	3/4	.438	1.12
3/8	3300x6	7/8	.578	1.12
1/2	3300x8	1-1/16	.703	1.50
3/4	3300x12	1-1/4	.906	1.53

Reducer Coupling (Ref. SAE No. 130138)

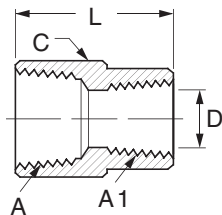
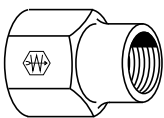

Fem. Pipe Thread A	Fem. Pipe Thread A1	Catalog Number	Hex C	D	L
1/4	1/8	3300x4x2	3/4	.339	.96
3/8	1/8	3300x6x2	7/8	.339	.94
3/8	1/4	3300x6x4	7/8	.438	1.16
1/2	3/8	3300x8x6	1-1/16	.562	1.38

Restriction Pipe Adapter (With .0625 Orifice)

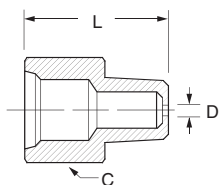
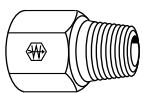

*PTF short thread.

Male Pipe Thread	Female Pipe Thread	Catalog Number	Hex C	D	L
1/8	1/8*	1512	1/2	.0625	.75

Fuel Line Adapter

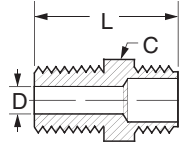

Inv. Tube Size	Male Pipe Thread	Catalog Number	Hex C	D	L
1/2-20	1/8	1514	1/2	.219	.90

Hex Nipple (Ref. SAE No. 130137)

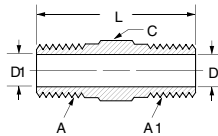
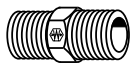

*Optional Counterbore .312

Male Pipe Thread A	Male Pipe Thread A1	Catalog Number	Hex C	D	D1	L
1/16	1/16	3325x1	3/8	.125	.125	.978
1/8	1/16	3325x2x1	7/16	.230	.156	.955
1/8	1/8	3325x2	7/16	.219	.219	.97
1/4	1/8	3325x4x2	9/16	.219	.219*	1.19
1/4	1/4	3325x4	9/16	.312	.312	1.38
3/8	1/8	3325x6x2	11/16	.219	.438	1.22
3/8	1/4	3325x6x4	11/16	.312	.438	1.41
3/8	3/8	3325x6	11/16	.438	.438	1.41
1/2	1/2	3325x8	7/8	.562	.562	1.81
3/4	3/4	3325x12	1-1/16	.750	.750	1.94

Close Nipple

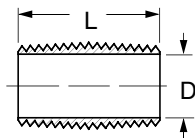
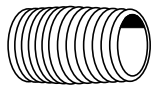

Male Pipe Thread	Catalog Number	D	L
1/8	3326x2	.281	.75
1/4	3326x4	.375	.88
3/8	3326x6	.500	1.00
1/2	3326x8	.625	1.12
3/4	3326x12	.750	1.38

Long Nipple

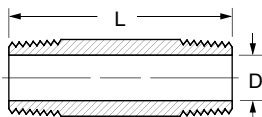
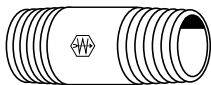

Male Pipe Thread	Catalog Number	D	L
1/8	3327x2	.281	1.50
1/8	3328x2	.281	2.00
1/8	3329x2	.281	2.50
1/8	3330x2	.281	3.00
1/8	3331x2♦	.281	3.50
1/4	3327x4	.375	1.50
1/4	3328x4	.375	2.00
1/4	3329x4	.375	2.50
1/4	3330x4	.375	3.00
3/8	3327x6	.480	1.50
3/8	3328x6	.490	2.00
3/8	3329x6	.480	2.50
3/8	3330x6	.480	3.00
3/8	3331x6♦	.480	3.50
1/2	3328x8	.625	2.00
1/2	3329x8	.625	2.50
1/2	3330x8	.625	3.00
3/4	3328x12♦	.750	2.00
3/4	3329x12	.750	2.50

♦MTO - Made To Order

Bulkhead Coupling (Brass)

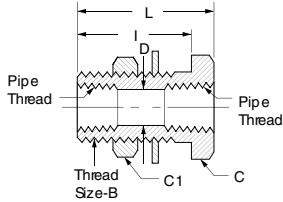
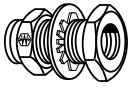

Fem. Pipe Thread	Catalog Thread	Thread Size B	Hex C	Hex C1	D	I	L
1/4	1344	3/4-16	1	15/16	.422	1.25	1.50
1/4	1345	3/4-16	1	15/16	.422	.69	.94
3/8	1346	1-14	1-1/8	1-3/8	.563	1.06	1.31
1/2	1351	1-1/8-14	1-1/4	1-3/8	.703	1.19	1.50

Bulkhead Coupling (Brass)

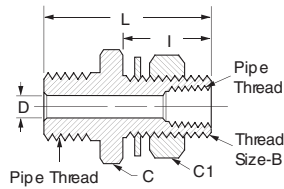
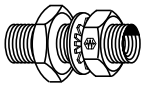

Male Pipe Thread	Fem. Pipe Thread	Catalog Number	Thread Size B	Hex C	Hex C1	D	I	L
1/2	1/4	1340	3/4-16	1-1/4	15/16	.312	1.13	2.16
1/2	1/4	1341	3/4-16	1-1/4	15/16	.312	1.53	2.53

Bulkhead Coupling (Brass)

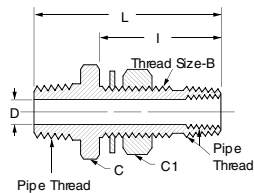
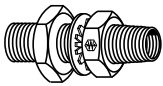

Male Pipe Thread	Fem. Pipe Thread	Catalog Number	Thread Size B	Hex C	Hex C1	D	I	L
1/2	1/4	1342	1-14	1-1/4	1-3/8	.375	1.88	2.94
1/2	1/4	1343	1-14	1-1/4	1-3/8	.375	2.88	3.94

**45° Street Elbow
(Ref. SAE No. 130339)**

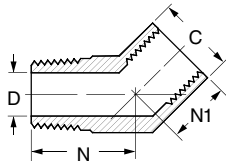

Male Pipe Thread	Fem. Pipe Thread	Catalog Number	C	D	N	N1
1/8	1/8	3350x2	9/16	.219	.50	.38
1/4	1/4	3350x4	11/16	.312	.74	.56
3/8	3/8	3350x6	13/16	.438	.78	.56
1/2	1/2	3350x8	1	.562	1.00	.76
3/4	3/4	3350x12	1-1/4	.750	1.06	.75

**90° Street Elbow
(Ref. SAE No. 130239)**

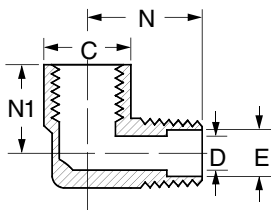
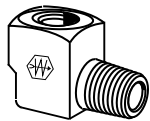

Fem. Pipe Thread	Male Pipe Thread	Catalog Number	C	D	E	N	N1
1/8	1/8	3400x2	9/16	.219	.25	.66	.47
1/8*	1/8**	3400x2W	1/2	.188	.25	.57	.34
1/4	1/8	3400x4x2	11/16	.219	—	.72	.53
1/4*	1/4**	3400x4W	11/16	.266	.36	.78	.45
1/4	1/4	3400x4	11/16	.312	—	.91	.72
3/8	3/8	3400x6	13/16	.438	—	.97	.78
1/2	1/2	3400x8	1	.562	—	1.25	1.03
3/4	3/4	3400x12	1-1/4	.750	—	1.38	1.12

* PTF Short Thread
** PTF Special Short Thread

90° Elbow (Ref. SAE No. 130238)

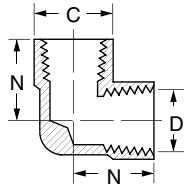
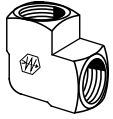

Fem. Pipe Thread	Catalog Number	C	D	N
1/8	3500x2	9/16	.339	.55
1/4	3500x4	11/16	.438	.78
3/8	3500x6	13/16	.562	.84
1/2	3500x8	1	.703	1.09
3/4	3500x12	1-1/4	.906	1.16

Male Branch Tee (Ref. SAE No. 130425)

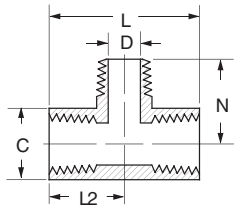
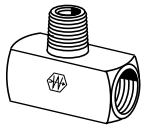

Fem. Pipe Thread	Male Pipe Thread	Catalog Number	C	D	L	L2	N
1/8	1/8	3600x2	9/16	.219	1.10	.55	.66
1/4	1/4	3600x4	11/16	.312	1.56	.78	.91
3/8	3/8	3600x6	13/16	.438	1.68	.84	.97
1/2	1/2	3600x8	1	.562	2.18	1.09	1.25
3/4	3/4	3600x12	1-1/4	.750	2.31	1.16	1.38

Tee (Ref. SAE No. 130438)

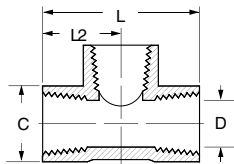
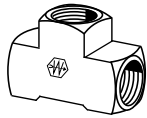

Fem. Pipe Thread	Catalog Number	C	D	L	L2
1/16	3700x1♦	7/16	.141	.96	.48
1/8	3700x2	9/16	.339	1.10	.55
1/4	3700x4	11/16	.438	1.56	.78
3/8	3700x6	13/16	.562	1.68	.84
1/2	3700x8	1	.703	2.18	1.09
3/4	3700x12	1-1/4	.906	2.32	1.16

Male Run Tee (Ref. SAE No. 130424)

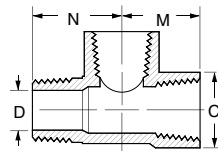
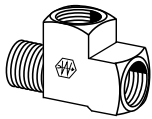

Fem. Pipe Thread	Male Pipe Thread	Catalog Number	C	D	M	N
1/8	1/8	3750x2	9/16	.219	.55	.66
1/4	1/4	3750x4	11/16	.312	.78	.90
3/8	3/8	3750x6	13/16	.438	.84	.97
1/2	1/2	3750x8	1	.562	1.09	1.25
3/4	3/4	3750x12	1-1/4	.750	1.16	1.38

Cross

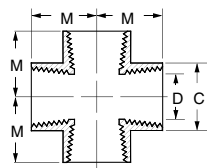
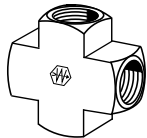

Fem. Pipe Thread	Catalog Number	C	D	M
1/8	3950x2	1/2	.339	.50
1/4	3950x4	11/16	.438	.75
3/8	3950x6	7/8	.562	.81
1/2	3950x8	1	.703	1.09
3/4	3950x12♦	1-1/4	.906	1.16

♦MTO - Made To Order

 Refer to safety information regarding tubing selection on page 1.

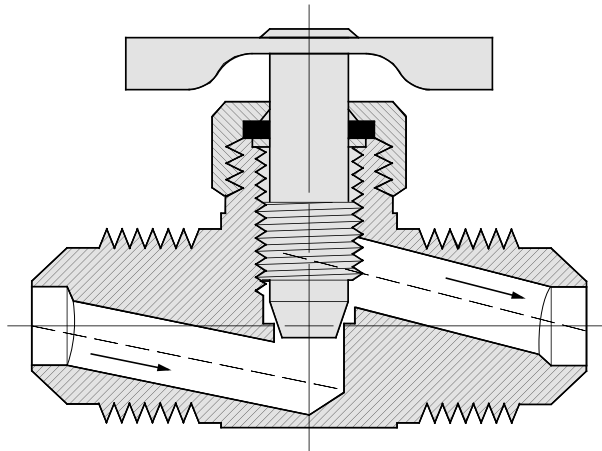

• **Typical Application**

Instrumentation, hydraulic and pneumatic systems.

• **Pressure**

150 psi maximum. (Does not include plastic tubing.)

• **Temperature Range**

-65°F to +250°F (-53°C to +121°C) with metal tubing. For valves using compatible tubing, refer to the tubing temperature range.

• **Material**

Brass bodies, steel handles except where noted. POLYLINE® valves have brass bodies and brass handles.

• **Used With**

Copper, aluminum, steel and plastic tubing where applicable. When using POLYLINE® valves, use aluminum and copper tubing with brass sleeve only. Plastic tubing may be used with either brass or plastic sleeve.

• **Advantages**

Metal-to-metal seat, with fine thread screwdown, enables valves to seat positively, adjust easily and hold to any amount of flow up to capacity of the valve.

• **Conformance**

Designed for automotive and industrial use. Not intended for natural gas, LPG, nuclear or aircraft applications.

• **How to Order**

Order valve body, nuts and sleeves by catalog number. Order valve with SELFALIGN® nuts and sleeves by adding suffix "S". Example: A6763 becomes A6763S. Order valves less nuts and sleeves by adding prefix "B". Example: A6763 becomes B6763.

• **Assembly Instructions**

1. Install with the pressure against the seat. Inspection of a straight valve discloses one opening to be higher than the other. Pressure should always be directed against the seat in angle valves, not the stem threads.

Needle Valves

**Brass
Fittings**

Compression Double

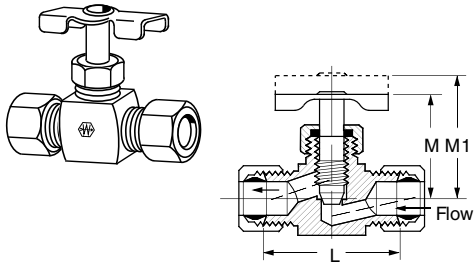

"S" suffix designates Selfalign® with nuts and sleeves.

Tube O.D.	Catalog Number	L	M	M1
3/16	A6763	1.06	.88	1.03
3/16	A6763S	1.06	.88	1.03
1/4	A6765	1.13	.88	1.03
1/4	A6765S	1.13	.88	1.03
5/16	A6770	1.13	.88	1.03
3/8	A6775	1.50	1.13	1.31
3/8	A6775S	1.50	1.13	1.31

Compression Straightway

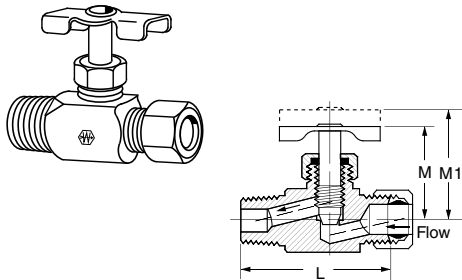

"S" suffix designates Selfalign® with nuts and sleeves.

Tube O.D.	Male Pipe Thread	Catalog Number	L	M	M1
3/16	1/8	A6690	1.16	.88	1.03
3/16	1/8	A6690S	1.16	.88	1.03
1/4	1/8	A690	1.19	.88	1.03
1/4	1/8	A690S	1.19	.88	1.03
5/16	1/8	A660	1.18	.90	1.05
5/16	1/4	A6755	1.28	.91	1.09
5/16	1/4	A6755S	1.28	.91	1.09
3/8	1/4	A6760	1.82	1.31	1.46
3/8	1/4	A6760S	1.82	1.31	1.46

Compression Angle

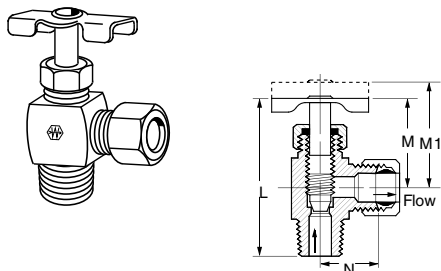

"S" suffix designates Selfalign® with nuts and sleeves.

Tube O.D.	Male Pipe Thread	Catalog Number	L	M	M1	N
3/16	1/8	A6845	1.50	.82	1.07	.50
3/16	1/8	A6845S	1.50	.82	1.07	.50
1/4	1/8	A555	1.53	.83	1.05	.53
1/4	1/8	A555S	1.53	.83	1.05	.53
5/16	1/8	A655	1.56	.84	1.09	.52
5/16	1/8	A655S	1.56	.84	1.09	.52
5/16	1/4	A6855	1.73	.92	1.28	.69
5/16	1/4	A6855S	1.73	.92	1.28	.69
3/8	1/4	A6860	1.64	.83	1.28	.78
3/8	1/4	A6860S	1.64	.83	1.28	.78

Inverted Straightway

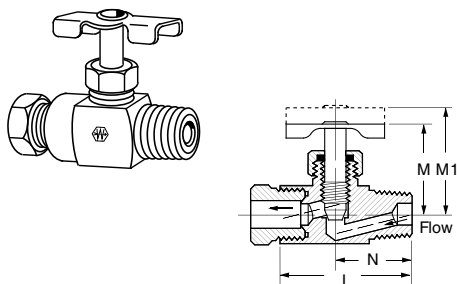

For replacement nut use [105x4](#). See page 38.
"B" prefix designates less inverted nut.

Tube O.D.	Male Pipe Thread	Catalog Number	L	M	M1	N
1/4	1/8	A735	1.38	.84	1.01	.69
1/4	1/8	B735	1.38	.84	1.01	.69

BRASS

Male Pipe Double

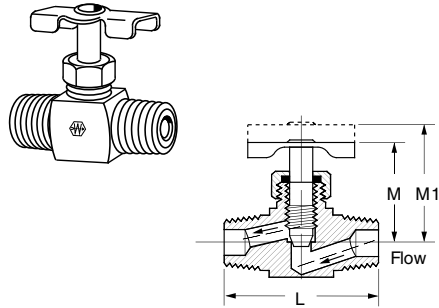

Male Pipe Thread	Catalog Number	L	M	M1
1/8	6810	1.38	.66	.80
1/4	6815	1.62	1.08	1.23

Male to Female Pipe

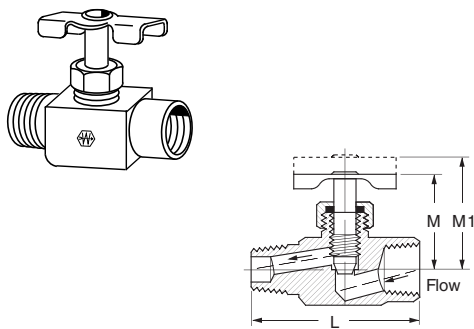

Fem. Pipe Thread	Male Pipe Thread	Catalog Number	L	M	M1
1/8	1/8	6820	1.18	.88	1.03
1/4	1/4	6825	1.88	1.09	1.24

Female Pipe

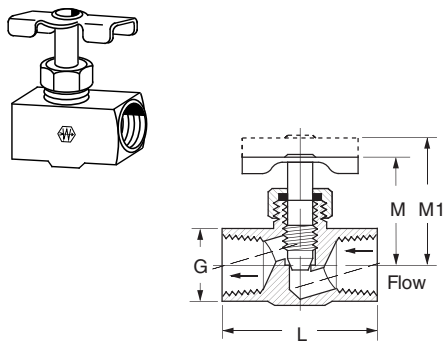

Fem. Pipe Thread	Catalog Number	L	M	M1	G
1/8	6800	1.12	.88	1.03	.50
1/4	6805	1.62	1.11	1.26	.69

SAE 45° Flare Double

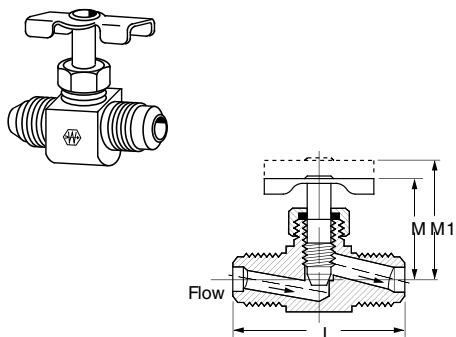

Tube O.D.	Catalog Number	L	M	M1
1/4	6715	1.38	.87	1.03

Needle Valves

**Brass
Fittings**

SAE 45° Flare Straightway

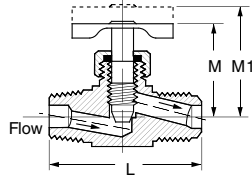
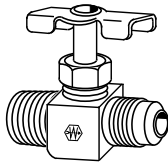

Tube O.D.	Male Pipe Thread	Catalog Number	L	M	M1
1/4	1/8	530	1.31	.88	1.03
1/4	1/4	6700	1.38	.88	1.09
5/16	1/8	630	1.38	.95	1.13
5/16	1/4	695	1.44	.87	1.02
3/8	1/4	700	1.68	1.00	1.15

SAE 45° Flare Angle

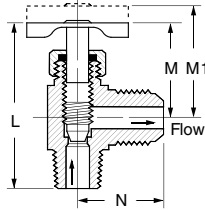
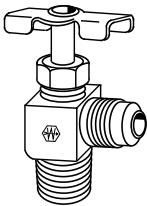

Tube O.D.	Male Pipe Thread	Catalog Number	L	M	M1	N
1/4	1/8	320	1.54	.86	1.07	.68
5/16	1/8	325	1.59	.94	1.22	.88
5/16	1/4	6703	1.94	1.00	1.31	.90
3/8	1/4	330	1.84	.90	1.21	.97

Polyline® Straightway

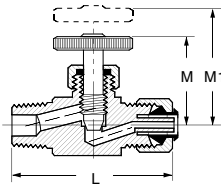
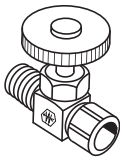

Tube O.D.	Male Pipe Thread	Catalog Number	L	M	M1
1/4	1/8	A690P	1.19	.86	1.01
3/8	1/4	A6760P	1.50	1.18	1.33

For replacement Polyline® nuts and sleeves, see page 61. Supplied with plastic sleeve.
Temperature Range: -40°F to +150°F with plastic sleeve.

Polyline® Angle

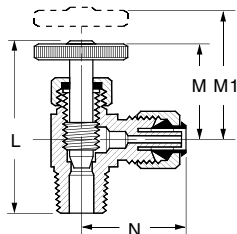
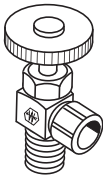

Tube O.D.	Male Pipe Thread	Catalog Number	L	M	M1	N
1/4	1/8	A555P	1.50	.82	1.04	.48
1/4	1/4	A556P	1.70	.84	1.06	.56
3/8	1/4	A6860P	1.85	.99	1.44	.64

For replacement Polyline® nuts and sleeves, see page 61. Supplied with plastic sleeve.
Temperature Range: -40°F to +150°F with plastic sleeve.

BRASS

⚠ Refer to safety information regarding tubing selection on page 1.

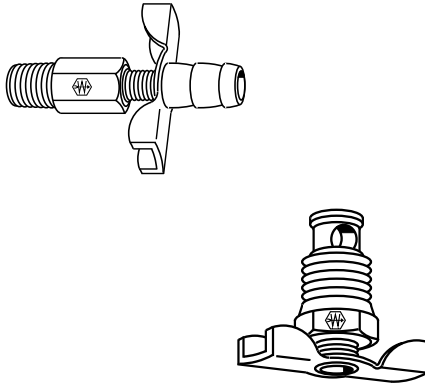

Drain Cocks and Drain Valves have been a specialty with Weatherhead since 1919. Millions are in use. The original design has proved so efficient that it is still the leader with most original equipment manufacturers. The metal-to-metal seat requires only hand tightening to assure positive leak-proof performance.

- **Material:** brass bodies/steel handles, except where noted.
- **Pressure:** 150 psi maximum (does not include hose or plastic tubing.)
- **Used With:** Copper, aluminum, steel, hose and plastic tubing where applicable.
- **Temperature:** -65°F to +250°F (-53°C to +121°C). (Refer to tubing temperature range.)
- **Conformance:** Designed for automotive or industrial use. Not intended for natural gas, LPG, nuclear or aircraft applications, except as noted.

External Seat

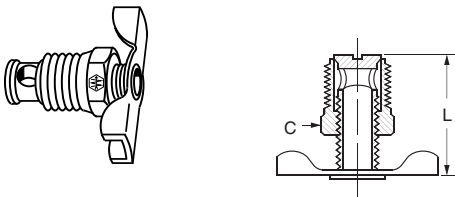

Male Pipe Thread	Catalog Number	Hex C	L
1/8	135	7/16	.90
1/4	145	9/16	1.00
3/8	270	11/16	1.25
1/2	108	7/8	1.52

External Seat

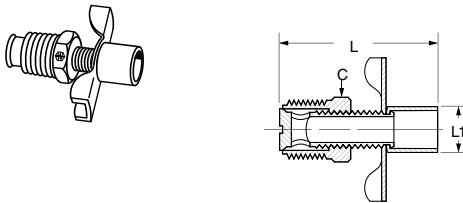

Male Pipe Thread	Catalog Number	Hex C	L	L1
1/4	6788	9/16	1.56	.44

Internal Seat

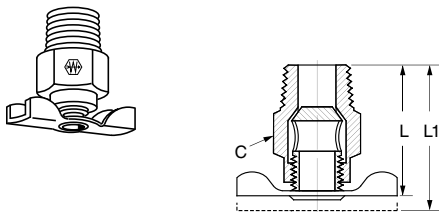

Male Pipe Thread	Catalog Number	Hex C	L	L1
1/8	130	17/32	1.15	1.30
1/4	140	5/8	1.32	1.50
1/4	190	9/16	1.25	1.41
3/8	230	11/16	1.34	1.50

Internal Seat (Long)

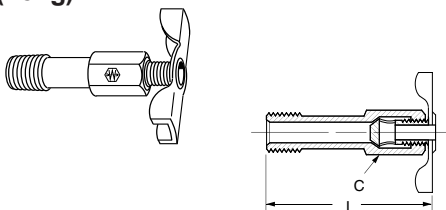

Male Pipe Thread	Catalog Number	Hex C	L
1/8	185	7/16	1.72

Drain Cocks

**Brass
Fittings**

Internal Seat

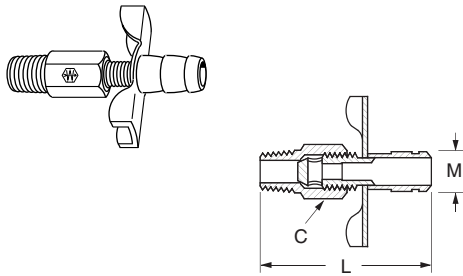

Male Pipe Thread	Catalog Number	Hex C	L	M
1/8	6783	13/32	1.63	.344

Internal Seat Drain Valve

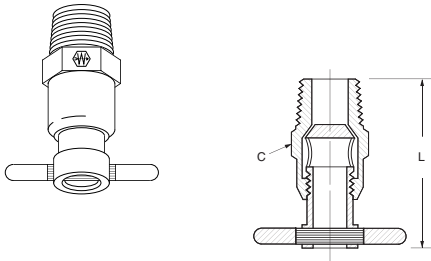

Male Pipe Thread	Catalog Number	Hex C	L
1/8	1424A	1/2	1.219
1/4	1425A	9/16	1.313
3/8	1426A	11/16	1.688

Air Vent

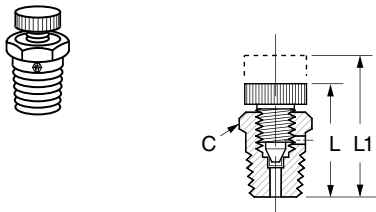

Set screw has 10-32 national fine thread.

Male Pipe Thread	Catalog Number	Hex C	L	L1
1/8	705	13/32	.78	.88

Angle Bib Drain

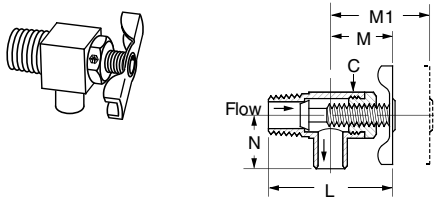

Male Pipe Thread	Catalog Number	Square C	L	M	M1	N
1/8	150	7/16	1.12	.57	.95	.38
1/4	120	5/8	1.76	.94	1.50	.66

Angle Bib Drain

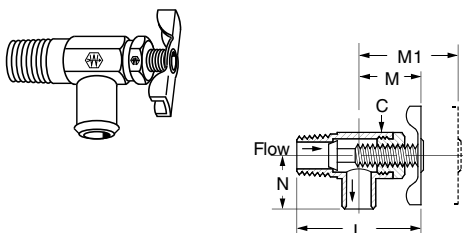

Hose I.D.	Male Pipe Thread	Catalog Number	Square C	L	M	M1	N
3/8	1/4	6660	9/16	1.33	.62	1.01	.66

BRASS

Hose to Pipe (Steel Body)

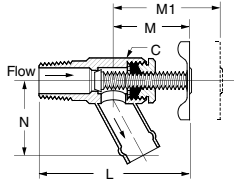
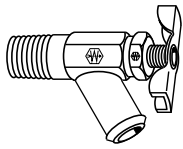

Hose Size	Male Pipe Thread	Catalog Number	Hex C	L	M	M1	N
5/8	3/8	211273A	11/16	2.85	1.41	1.91	1.30

Hose to Pipe (Steel Body)

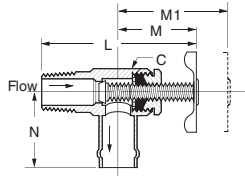
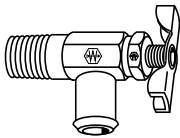

Hose I.D.	Male Pipe Thread	Catalog Number	Square C	L	M	M1	N
5/8	3/8	211280A	11/16	2.85	1.10	1.47	1.19

Pipe to Hose Shut-Off (Brass Body)

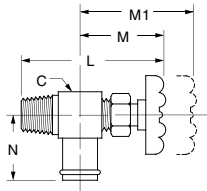
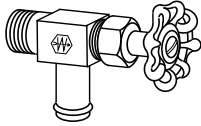

Red color coded aluminum handle.
Handle Catalog Number [1427](#).

Hose Size	Male Pipe Thread	Catalog Number	Square C	L	M	M1	N
3/8	3/8	1422	3/4	2.93	1.78	2.25	1.12
5/8	3/8	1423	13/16	2.93	1.81	2.25	1.35
3/4	3/8	1433	15/16	3.00	1.81	2.25	1.35
3/4	1/2	1451	15/16	3.12	1.93	2.25	1.35

Gasoline Shut-Off with Screen Filter

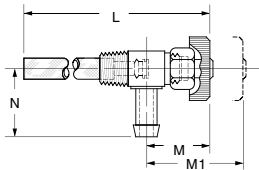
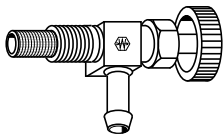

Hose Size	Male Pipe Thread	Catalog Number	L	M	M1	N
1/4	1/8	6600	3.36	.80	.97	.84

Air Tank Drain Valve

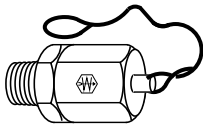

NOTE: Pull cable sideways.
*No loop on cable end.

Male Pipe Thread	Cable Length	Catalog Number
1/4	7"	1421-7
1/4	18"	1421-18
1/4	24"	1421-24
1/4	32"	1421-32
1/4	60"	1421-60
1/4	60"	1421-60A*

Truck Valves

Brass Fittings

Typical Application: Used extensively in the trucking industry for cooling and fuel line applications.

Material: Forged brass bodies, steel handles.

Pressure Range: 200 psi maximum.

Temperature: -40°F to +250°F (-40°C to +121°C)

Conformance: Designed for trucking use. Not intended for natural gas, LPG, nuclear or aircraft applications.

Note: Buna-N o-ring sealed; Viton available on special order.

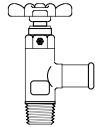
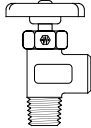
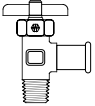
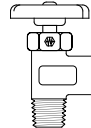
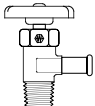
Truck Valve 	Hose I.D.	Pipe Thread	Catalog Number	Truck Valve 	Female Pipe Thread	Male Pipe Thread	Catalog Number
	5/8	1/2	7502		1/2	1/2	7508
Truck Valve 	Hose I.D.	Pipe Thread	Catalog Number	Truck Valve 	Female Pipe Thread	Male Pipe Thread	Catalog Number
	5/8	3/8	7504		3/8	3/8	7509
Truck Valve 	Hose I.D.	Pipe Thread	Catalog Number				
	3/8	3/8	7506				

BRASS

Plastic Drain Cocks

Brass Fittings











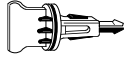

Material: Nylon 6 Fiber Reinforced.

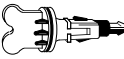
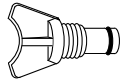
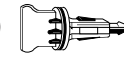
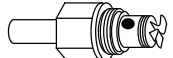
Pressure Range: Up to 25 psi.

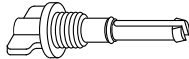
Used With: Automotive Radiators

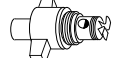
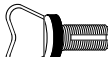
Temperature: -50°F to +180°F (-46°C to +82°C)

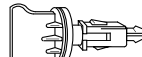
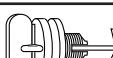
Conformance: Designed for automotive use. Not intended for natural gas, LPG, nuclear or aircraft applications.

Chrysler 	Thread Captive	Catalog Number 110	M12x1.5 	Thread M12x1.5	Catalog Number 119
GM 	Thread Oversized	Catalog Number 111	Ford and Mazda 	Thread M10x1.25	Catalog Number 121
Ford (Long) 	Thread Captive	Catalog Number 112	M14x2.0 	Thread M14x2.0	Catalog Number 122
Ford (Short) 	Thread Captive	Catalog Number 113	Chrysler 	Thread 5/8-18	Catalog Number 123
M12x1.25 	Thread M12x1.25	Catalog Number 114	Ford 	Thread M14x2.0	Catalog Number 124
M14x1.25 	Thread M14x1.25	Catalog Number 115	Chrysler 	Thread 5/8-18	Catalog Number 125
M10x1.25 	Thread M10x1.25	Catalog Number 116	Chrysler 	Thread 5/8-18	Catalog Number 126
M14x1.25 	Thread M14x1.25	Catalog Number 117	GM 	Thread Captive	Catalog Number 127
M10x1.25 	Thread M10x1.25	Catalog Number 118	GM 	Thread 1/2-18	Catalog Number 128

Refer to safety information regarding tubing selection on page 1.

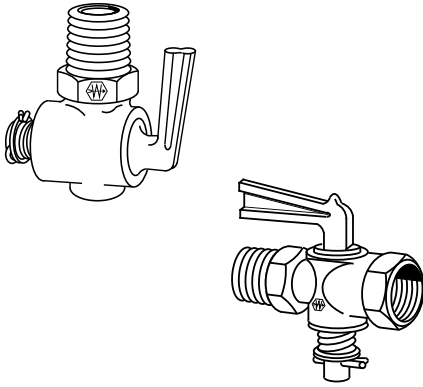

Pressure Range: 30 psi working pressure, except where noted.
Used With: Copper, aluminum, steel and plastic tubing where applicable.
Material: Brass bodies and handles.
Temperature: -65°F to +250°F (-53°C to +121°C) with metal tubing. For use with plastic tubing, refer to the tubing temperature range.
Conformance: Designed for automotive or industrial use. Not intended for natural gas, LPG, nuclear or aircraft applications, except as noted.
Ordering Information: Order valve body, nut and sleeves by catalog number. Order valves with Selfalign® nuts and sleeves by adding suffix "S". Example: A694S. Order valves less nut and sleeve by adding prefix "B". Example: B694.
NOTE: Ground Plug Drains and Shut-Offs use a universal lubricant satisfactory for use with most common fluids. However the lubricant may wash out at higher pressures or with some exotic fluids.

Draincock

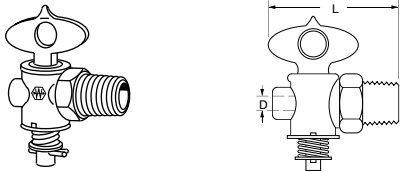

Ratings: Valves are designed to hold air pressure of 150 psi with one 1/4" bubble in 5 seconds permissible key leakage.

Male Pipe Thread	Catalog Number	D	L
1/4	W15310	.188	1.56

Ground Plug Drain

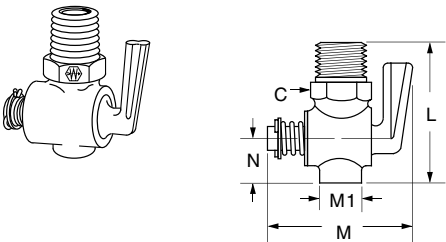

Male Pipe Thread	Catalog Number	Hex C	L	N	M	M1
1/8	6891	9/16	1.93	.75	1.63	.87
1/4	6892	5/8	1.62	.75	1.75	1.03
3/8	6893	11/16	1.72	1.00	2.31	1.22

Compression Flareless 3 Way Shut-Off

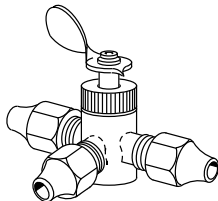

Tube O.D.	Catalog Number	Replacement Nuts	Replacement Sleeves
5/16	A6793	1611x5*	60x5

SAE 45° Flare Double

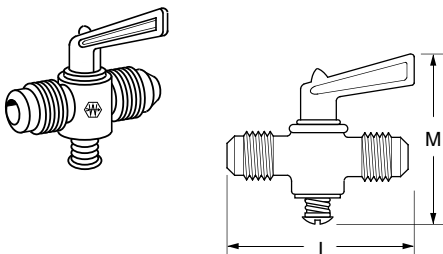

Tube O.D.	Catalog Number	L	M
1/4	6719	1.88	1.88
5/16	6724	1.88	1.88
3/8	6729	2.00	1.88

*MTO - Made To Order

Ground Plug & Multiple Shut-Offs

**Brass
Fittings**

SAE 45° Flare Straightway

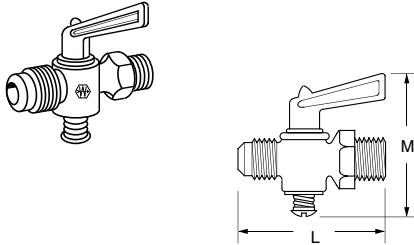

Tube O.D.	Male Pipe Thread	Catalog Number	L	M
1/4	1/8	537	2.00	1.88
5/16	1/8	632	2.03	1.88
5/16	1/4	702	2.03	1.88
3/8	1/4	703	2.06	1.88

Compression Double

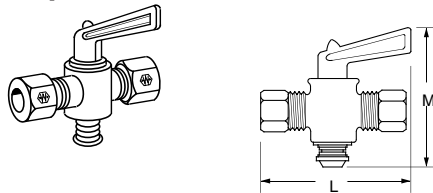

"S" suffix designates Selfalign® with Nuts and Sleeves.

Tube O.D.	Catalog Number	L	M
1/4	A6769	2.12	1.88
1/4	A6769S	2.12	1.88
5/16	A6774	2.19	1.88
3/8	A6779	2.25	1.88
3/8	A6779S	2.25	1.88

Compression Straightway

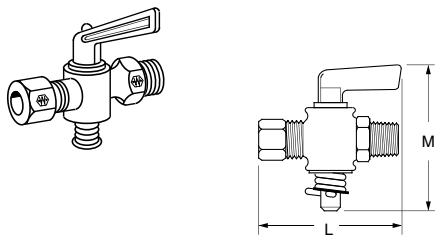

"S" suffix designates Selfalign® with Nuts and Sleeves.

Tube O.D.	Male Pipe Thread	Catalog Number	L	M
1/4	1/8	A694	2.19	1.88
1/4	1/8	A694S	2.19	1.88
1/4	1/4	A6754	2.19	1.88
1/4	1/4	A6754S	2.19	1.88
5/16	1/8	A664	2.19	1.88
5/16	1/4	A6759	2.25	1.88
3/8	1/4	A6764	2.38	1.88
3/8	1/4	A6764S	2.38	1.88

Male to Female Pipe

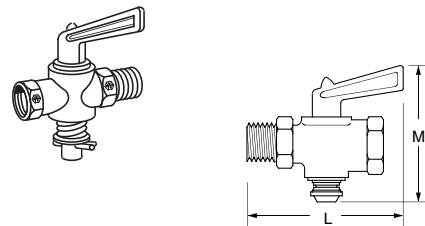

Male Pipe Thread	Female Pipe Thread	Catalog Number	L	M
1/8	1/8	6824	2.00	1.88
1/4	1/4	6829	2.12	1.88

Truck Shut Off Male to Female Pipe

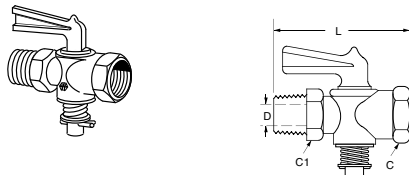

Ratings: Valves are designed to hold air pressure of 125 psi with one 1/4" bubble in 5 seconds permissible key leakage.

Male Pipe Thread	Female Pipe Thread	Catalog Number	Hex C	Hex C1	L	D
1/4	1/4	W20332	5/8	3/4	1.96	.219

BRASS

Marine Shut Off Male to Female Pipe

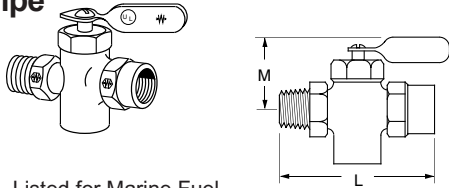

UL Listed for Marine Fuel.

Male Pipe Thread	Female Pipe Thread	Catalog Number	L	M
1/4	1/4	6828	2.22	1.97

Female Pipe Double

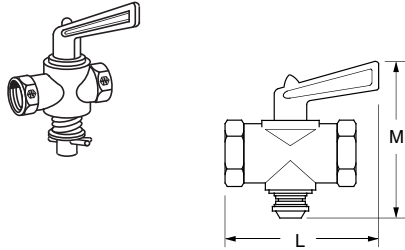

Female Pipe Thread	Catalog Number	L	M
1/8	6804	1.46	1.88
1/4	6809	1.70	1.88

3 Way Shut-Off

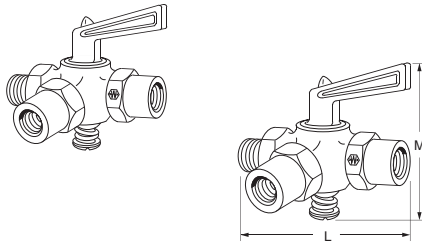

Male Pipe Thread	Female Pipe Thread	Catalog Number	L	M
1/8	1/8	6737	2.12	1.88

3 Way Multiple Shut-Off

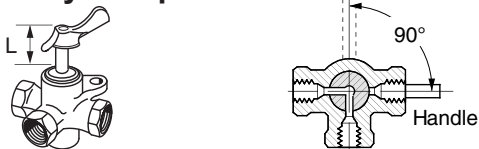

Replacement Handle: Catalog Number **6746**.
Includes Screw.
Click-washer assembly positively holds valve in desired position and gives a pronounced click.

Female Pipe Thread	L Stem	Catalog Number
1/4	1.37	6749
3/8	1.37	6709

4 Way Multiple Shut-Off

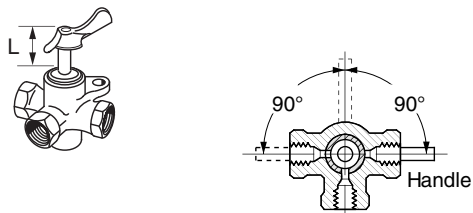

Replacement Handle: Catalog Number **6746**.
Includes Screw.
Click-washer assembly positively holds valve in desired position and gives a pronounced click.

Female Pipe Thread	L Stem	Catalog Number
1/4	1.37	6747
1/4	2.37	6748
3/8	1.37	6707
3/8	2.37	6708

Special Adapters

Brass Fittings

 Refer to safety information regarding tubing selection on page 1.

Turbocharger Discharge Connector

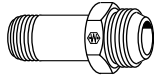

Male Straight Thread	Male Pipe Thread	Catalog Number	Hex C	D	L
1 AC-811 30° Flare Tube	3/4	1408	1-3/8	.719	3.25

Wiper Tee

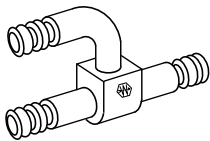

Hose I.D.	Catalog Number	M	M1	N
1/4	1410	.88	1.00	1.02

Transmission Oil Coolant Line Adapter

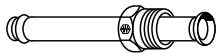

Tube O.D.	Inverted Nut	Catalog Number	Hex C	L
5/16	5/16	1428	1/2	4.50
3/8	3/8	1429	5/8	4.50

Water Line Connector

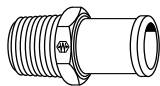

Hose I.D.	Male Pipe Thread	Catalog Number	Hex C	D	L
5/8	3/8	05710B-106	3/4	.464	1.50
5/8	1/2	05710B-108	7/8	.531	1.88
3/4	1/2	05712B-108	7/8	.594	1.88

For additional 057B Series ends consult the Boston Weatherhead Hose Assembly Catalog.

Truck Oil Line Extended SAE 45° Flare Fitting (Replaces Roto Master No. 10-35)

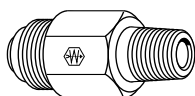

SAE 45° Tube Size	Male Pipe Thread	Catalog Number	Hex C	D	L
3/8	1/4	1432	5/8	.282	1.90

 Refer to safety information regarding tubing selection on page 1.

Ford Transmission Elbow

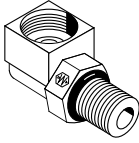

Includes O-Rings.

Tube O.D.	Straight Male Pipe Thread	Catalog Number	M	N
5/16-28	1/8-27	1437	.94	.47

Power Steering Male 37° JIC Adapter (Brass)

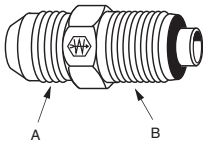

Includes O-Ring.

Tube O.D.	Thread A	Thread B	Catalog Number	Hex C	D	L
1/4	7/16-20	9/16-18	1440	9/16	.172	1.42
3/8	9/16-18	5/8-18	1439	5/8	.266	1.49

Metric Power Steering Adapter

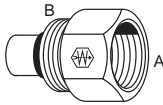

Includes O-Ring.

Tube O.D.	Inverted Thread A	Thread B	Catalog Number	Hex C	D	L
3/8	5/8-18	M14x1.5	1445	3/4	.266	1.18
3/8	5/8-18	M16x1.5	1446	3/4	.266	1.18
3/8	5/8-18	M18x1.5	1447	3/4	.266	1.18

Ford Power Steering Fitting

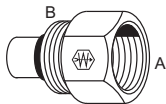

Includes O-Ring.

Inverted Thread A	Male O-Ring B	Catalog Number	Hex C	D	L
5/8-18	11/16-18	1444	3/4	.266	1.38

Restriction Pipe Adapter (With .0625 Orifice)

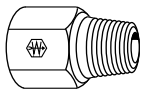

* PTF short thread.

Male Pipe Thread	Female Pipe Thread	Catalog Number	Hex C	D	L
1/8	1/8*	1512	1/2	.0625	.75

Special Adapters

**Brass
Fittings**

 Refer to safety information regarding tubing selection on page 1.

Carburetor to Fuel Line Adapter (Ford)

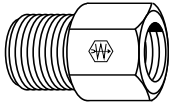

For use with **59x4**

Tube O.D.	Thread Size	Male Pipe Thread	Catalog Number	Hex C	D	L
1/4	1/2-20	1/8	1513	9/16	.219	1.06

Fuel Line Adapter

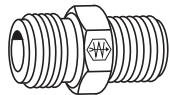

Inverted Male	Male Pipe Thread	Catalog Number	Hex C	D	L
1/2-20	1/8	1514	1/2	.219	.90

AC Type Adapter

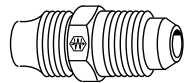

Tube O.D.	S.A.E. 45° Tube Size	Catalog Number	Hex C	D	L
1/4	1/4	1521	7/16	.188	1.09

Adapter SAE 45° Flare to Inv. Flare



SAE 45° Tube Size	Inverted Male	Catalog Number	Hex C	D	L
1/4	3/16	1518	7/16	.189	1.03
1/4	1/4	1522	7/16	.189	1.03
3/8	5/16	1553	5/8	.234	1.34
3/8	3/8	1563	5/8	.282	1.38
3/8	7/16	1554	11/16	.282	1.40

Carburetion Inlet (Steel)



Inv. Seat	Male Thread	Catalog Number	Hex C	D	L
3/8	7/8-20	1596	1	.281	.91
5/16	7/8-20	1597	1	.217	.91

B
R
A
S
S

 Refer to safety information regarding tubing selection on page 1.

Special Steel Bushing

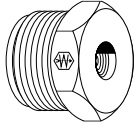

Male Thread	Female Pipe Thread	Catalog Number	Hex C	D	L
1-1/16-16UN-2A	1/8	7977	1-1/8	.328	.94
1-1/16-16UN-2A	3/8	7978	1-1/8	.562	.94

Water Line Elbow

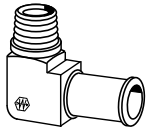

Hose I.D.	Male Pipe Thread	Catalog Number	D	M	N
5/8	3/8	05710B-C06	.500	1.25	1.35

Male JIC 37° Flare to O-Ring Port Adapter (Steel)

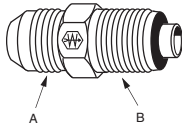

Tube Size A	Port Size B	Catalog Number	Thread B	Hex C	D	L
1/4	1/4	41157x4	7/16-24	7/16	.122	1.33
3/8	3/8	41157x6	5/8-18	5/8	.262	1.47
1/2	1/2	41157x8	3/4-16	3/4	.368	1.91
5/8	5/8	41157x10	7/8-14	15/16	.472	2.23
3/4	3/4	41157x12	1-1/16-16	1-1/8	.609	2.13

Includes O-Ring.

Male JIC 37° Flare to Metric O-Ring Port Adapter (Steel) (with o-ring)

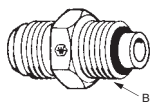

Tube O.D.	Thread B	Catalog Number	Hex C	D	L
3/8	M14x1.5	M41157x6x14	3/4	.266	1.62
3/8	M16x1.5	M41157x6x16	3/4	.266	1.62
3/8	M18x1.5	M41157x6x18	3/4	.266	1.62

Includes O-Ring.

Application: GM power steering with Saginaw steering and rack and pinion steering systems.

Special Adapters

Brass
Fittings

Ford Nut

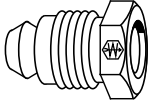

For use with **1513**
(Nut similar to **59x4** for 3/16" tube, use **6100x3**)

Tube Size	Thread Size	Catalog Number	Hex C	D	L
1/4	1/2-20	59x4	1/2	.258	.64

Transmission Coolant Line Adapters (GMC)

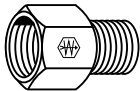

Inv. Female	Inv. Male	Catalog Number	Hex C	D	L
3/8 (5/8-18)	5/16 (1/2-20)	7915	3/4	.250	1.00
5/16 (1/2-20)	3/8 (5/8-18)	7916	5/8	.220	.94

AC8111 (Steel) Connector

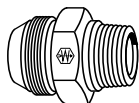

Application: PTT Thread 30° tube to male pipe adapter for diesel engines.

Tube Size	Male Pipe	Catalog Number	Hex C	D	L
1 (1-5/16-14)	1	C9200	1-3/8	.844	2.04
1 (1-5/16-14)	3/4	C9240	1-3/8	.800	1.84

B
R
A
S
S

 Refer to safety information regarding tubing selection on page 1.

Adapters can be used to adapt standard steel brake lines to the different size ports used in dual master cylinders. The tube O.D. is the outside diameter of the steel brake line. Thread size can be determined by measuring with a U.S. or Metric screw pitch gauge. See page 16.

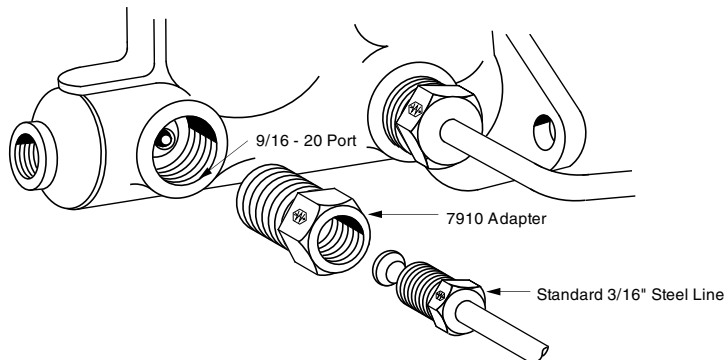

STANDARD INVERTED FLARE TUBE AND THREAD SIZE

Tube Size	1/8	3/16	1/4	5/16	3/8	7/16	1/2	5/8	3/4	7/8	1
Thread Size	5/16-28	3/8-24	7/16-24	1/2-20	5/8-18	11/16-18	3/4-18	7/8-18	1-1/16-16	1-3/16-16	1-5/16-16

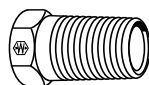
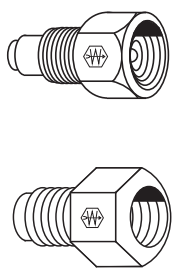
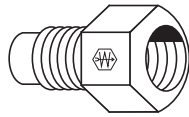
<p>Standard Tube Nut (Steel)</p>  <p>*11/16-18 Thread</p>	<p>Tube Size</p> <p>1/8 3/16 1/4 5/16 3/8 3/8 7/16 1/2 5/8 3/4 7/8 1</p> <p>Catalog Number</p> <p>105x2 105x3 105x4 105x5 105x6 105x6x7* 105x7 105x8 105x10 105x12 105x14 105x16</p>	<p>Long Tube Nut (Steel)</p> 	<p>Tube O.D.</p> <p>3/16 1/4</p> <p>Thread Size</p> <p>3/8-24 7/16-24</p> <p>Catalog Number</p> <p>7896x3 7896x4</p>
	<p>Dual Master Cylinder Adapter</p>  <p>Inverted Male Thread</p> <p>3/16 5/16</p> <p>Inverted Female Thread</p> <p>3/16 3/16</p> <p>Catalog Number</p> <p>1441 7897</p>		<p>Dual Master Cylinder Adapter</p>  <p>† Seat may be used for 3/16", 1/4", 5/16" Tube Connection with 1/2-20 Thread. *Seals On Hex Face (E)</p> <p>Inverted Male Thread (Exceptions Noted)</p> <p>3/16(9/16-18) 3/16(9/16-18) 3/16(9/16-20) 3/16 1/4 7/16-20 1/4 (9/16-18) 1/4 5/16 5/16 5/16 5/16 5/16 5/16 5/16 5/16 3/8 NPTF 3/8</p> <p>Inverted Female Thread (Exceptions Noted)</p> <p>3/16 3/16(1/2-20) 3/16 1/4 3/16 1/4 1/4 5/16† 3/16 3/16 3/16(9/16-18) 1/4 1/4 5/16 3/8 5/16 5/16</p> <p>Catalog Number</p> <p>7911 7913 7910 7828 7818 7732* 7908 7917 7817* 7909 7912 7727* 7829 1074* 7915 7771 7916</p>

Towed Trailer Brake Tee

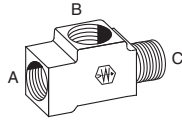

Inverted Seat		Male Thread		Catalog Number
A	B	C		
3/16 (3/8-24)	3/16 (3/8-24)	3/16 inv. (3/8-24)		7900
3/16 (1/2-20)	3/16 (3/8-24)	1/2-20 inv.		7906
3/16 (9/16-18)	3/16 (3/8-24)	3/16 inv. (9/16-18)		7933
3/16 (9/16-20)	3/16 (3/8-24)	3/16 inv. (9/16-20)		7905
3/16 (7/16-24)	3/16 (3/8-24)	1/4 inv. (7/16-24)		7914
1/4 (7/16-24)	3/16 (3/8-24)	1/4 inv. (7/16-24)		7901
1/4 (9/16-18)	3/16 (3/8-24)	1/4 inv. (9/16-18)		7904
1/4 (7/16-24)	1/4 (7/16-24)	1/4 inv. (7/16-24)		7898

Spring Lock



1/2" Clip or Spring Lock **5188**

Strap Tee Assembly

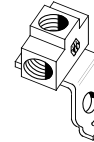

*Has flat strap

Inv. Seat	Bolt Hole	Catalog Number
3/16 (3)	11/32	7812
1/4 (3)	11/32	7765*

Metric Hydraulic Brake Fittings

How to Measure Metric Threads

Metric threads are measured and specified by the thread diameter in millimeters and the pitch in millimeters per thread. If dimension "A" is 22mm and dimension "B" (crest to crest distance) is 1.5mm, then the metric thread size is M22 x 1.5.

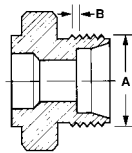

Brake Fittings



Inv. Seat	Bolt Hole	Catalog Number
1/4	19/32	7709

Metric Adapter

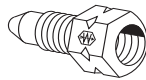

Male Thread	Tube O.D./ Female Thread	Catalog Number
M10 x 1.0	3/16 (3/8-24)	1442*
M11 x 1.5	3/16 (M10 x 1.0)	7935**
M12 x 1.0	3/16 (M10 x 1.0)	7936**
M13 x 1.5	3/16 (M10 x 1.0)	7937**

*Use S Series Brake Lines. (standard flare)

**Use SJ Series Steel Brake Lines. (standard flare)

Rear Axle Tee

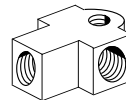

Inv. Seat	Bolt Hole	Hose End Port	Catalog Number
3/16 (2)	9/32	3/8-24	7805

Adapter Standard to Metric Bubble

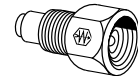

Female Std. Fl. Seat	Male Bubble Fl. Tube	Catalog Number
3/16" (3/8-24 thread)	4.762 (3/16") (10x1.25 thread)	7970

Used on Fiat applications when converting 3/16" (3/8-24) inverted flare brake lines to 3/16" (10x1.25) metric thread bubble flare.

Metric Adapter

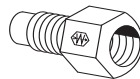

Male Thread	Tube O.D./ Female Thread	Catalog Number
M10 x 1.0	3/16 (3/8-24)	1443*

*Use S Series Brake Lines. (standard flare)

**Use SJ Series Steel Brake Lines. (standard flare)

Metric Union

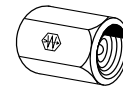

Bubble Fl. Seat	Thread Size	Catalog Number
3/16"	10 x 1.0	7975

For joining Edelmann 6300 Series metric thread bubble flare 3/16" brakelines.

Steel Brake Lines for Domestic Vehicles Standard Flare – “S” Series

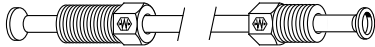

NOTE: 3/16" and 1/4" tube assemblies have one long (7896x) and one short (105x) inverted nut.

Length	Catalog Number 3/16" O.D.	Catalog Number 1/4" O.D.	Catalog Number 5/16" O.D.	Catalog Number 3/8" O.D.
6"	S306	—	—	—
8"	S308	S408	—	—
10"	S310	—	—	—
12"	S312	S412	S512	S612
20"	S320	S420	S520	S620
30"	S330	S430	S530	S630
40"	S340	S440	S540	S640
51"	S351	S451	S551	S651
60"	S360	S460	S560	S660
72"	S372	—	—	—
UNION	302x3	302x4	302x5	302x6

Steel Brake Lines for Imported Vehicles Standard Flare – “SJ” Series

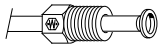

Bubble Flare – “SB” and “SC” Series

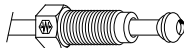

*Uses bubble flare
**Single notch on hex

Length	British Vehicles* 3/8-24 Thread Catalog Number 3/16" O.D.	Japanese Vehicles 10-1.0mm**Thread Catalog Number 3/16" O.D.	European Vehicles* 10-1.0mm Thread Catalog Number 3/16" O.D.
8"	SB308	SJ308	SC308
12"	SB312	SJ312	SC312
20"	SB320	SJ320	SC320
30"	SB330	SJ330	SC330
40"	SB340	SJ340	SC340
51"	SB351	SJ351	SC351
60"	SB360	SJ360	SC360
UNION	7940	7934A	7941

Brake Line Unions for Domestic and Imported Vehicles



Description	Catalog No.
3/16" line to 3/16" line (3/8–24 thread), (Standard Flare) ‘S’ Series	302x3
1/4" line to 1/4" (7/16–24 thread), (Standard Flare) ‘S’ Series	302x4
5/16" line to 5/16" line (1/2–20 thread), (Standard Flare) ‘S’ Series	302x5
3/8" line to 3/8" line (5/8–18 thread), (Standard Flare) ‘S’ Series	302x6
British line to British line (3/8–24 thread), (ISO flare) ‘SB’ Series (Steel)	7940
European line to European line (10–1.0mm thread), (Bubble Flare) ‘SC’ Series (Steel)	7941
Japanese line to Japanese line (10–1.0mm thread), (Standard Flare) ‘SJ’ Series (Brass)	7934A

 Refer to safety information regarding tubing selection on page 1.

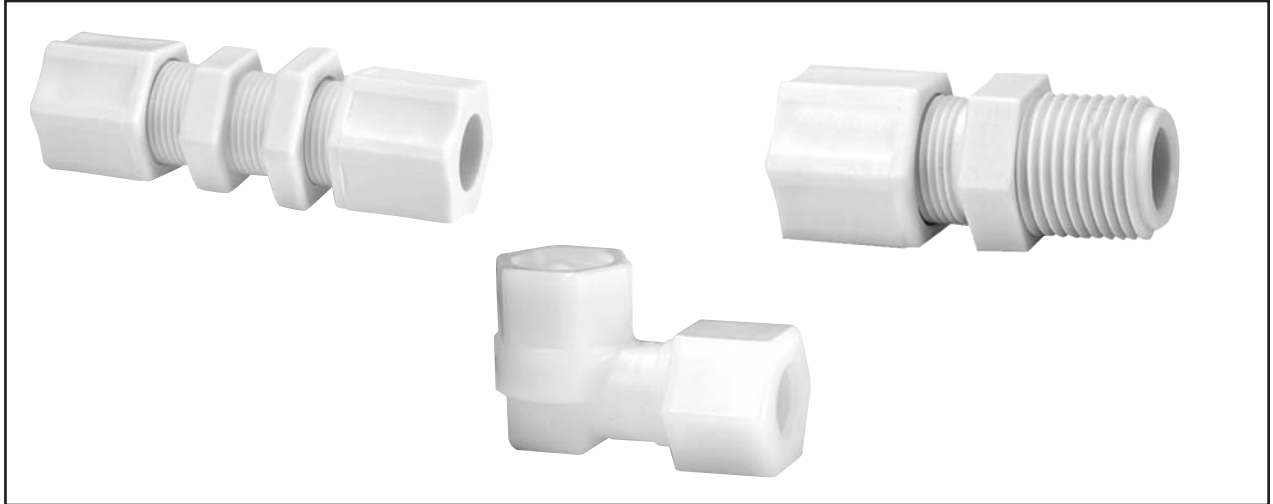

Weatherhead Molded Compression Tube Fittings

Sizes: Available in sizes 1/8" through 3/4" tube OD (7/8" tube OD and metric tube sizes available on request from Weatherhead Customer Satisfaction at 1-800-432-6006.)

Materials: Molded as standard in two materials: nylon and polypropylene

Nylon characteristics:

- good resistance to organic solvents, oils, and gasoline
- excellent impact resistance
- tolerant to repeated steam for wash down and longtime weathering
- F.D.A. and N.S.F. listed
- operating temperatures -40°F to 200°F (-40°C to 93°C) – not to exceed temperature specification of tubing

Polypropylene characteristics:

- good chemical and corrosion resistance
- opaque
- 20% glass filled
- N.S.F. listed
- operating temperatures -30°F to 200°F (-34°C to 93°C) – not to exceed temperature specification of tubing

Available on request in two materials: Celcon®* (acetal copolymer) or KYNAR®** (polyvinylidene fluoride)

Styles: Available in two standard styles:

Ferrule Nut (integral nut and sleeve for soft tubing to 50 PSI[♦])

- features ferrule and nut molded as a single part, eliminating the need for a two-piece assembly

Gripper Nut with separate plastic sleeve (for sure-grip with plastic tubing up to 220 PSI[♦])

- for higher pressure applications

Features and Benefits:

- leak-free performance
- high integrity in both mechanical and acoustical vibrations
- ten styles and over 400 part number configurations to meet your needs
- easy fitting assembly – no special tools or tube preparation necessary
- reliability in side-loaded applications allows for compact plumbing
- fittings are manufactured for use with PT200, PT240, and TP160 Boston Weatherhead plastic tubing
- fittings come fully assembled – for your convenience
- very low resistance to media flow resulting from material and internal surfaces
- no metal parts to corrode or present a safety hazard with aggressive chemicals
- ISO 9001 Certified

* Celcon® is a registered trademark of Ticona.

** KYNAR® is a registered trademark of Elf Atochem North America, Inc.

[♦] Operating temperatures of Weatherhead Tube Fittings are regulated by ambient and fluid temperatures, type of fluid being carried, tubing type and conditions of mechanical abuse. Pressures in excess of above specifications in all fitting sizes should be tested by the customer in the particular application.

Molded Compression Tube Fittings Assembly Instructions

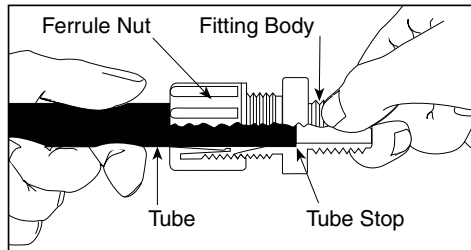

Maximum Operating Pressure:

Ferrule Nut series = 50 PSI max

Gripper Nut series = 220 PSI max

Maximum operating pressures are dictated by the combination of tubing and fitting. The lowest pressure of the individual components will decide the actual operating pressure of the assembly.

Temperature Range:

Nylon = -40°F to +200°F (-40°C to +93°C)

Polypropylene = -30°F to +200°F (-34°C to +93°C)

Ranges are at maximum operating pressures (refer to tubing temperature range). The overlap of temperature ranges of the individual components will decide the actual temperature range of the assembly.

Used with:

Weatherhead plastic tubing: TP160, PT200, and PT240.

Tube inserts are recommended for optimal performance with Weatherhead PT200 tubing.

FERRULE NUT
WITH INTEGRAL SLEEVE
LOW PRESSURE APPLICATIONS
SOFT PLASTIC TUBING
*50 P.S.I.

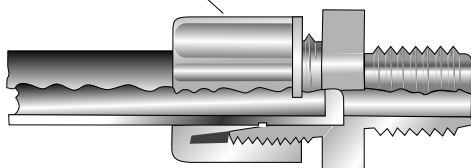

WITH PLASTIC GRIPPER
FOR USE WITH PLASTIC TUBING
FOR SURE GRIP
*220 P.S.I.

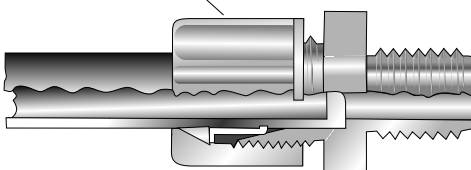

Assembly Instructions:

- Cut tubing to desired length; be sure the tube end is cut properly (maximum 10° cutting angle allowed).
- Insert the tubing through the back of the nut all the way through the nut assembly to the tube stop in the fitting body (see illustration). If the tubing does not enter the nut easily, loosen the nut one turn and then insert the tubing all the way to the tube stop in the fitting body.
- Turn the nut to hand-tight.
- Tighten the nut an additional 2 to 2-1/2 turns past hand-tight or until the nut bottoms against the fitting body, whichever comes first.
- All nuts must be retightened when the system reaches projected operating temperature.

Ordering Information

Molded compression tube fittings are available in nylon and in polypropylene. They are also available by special order in KYNAR^{®**} (polyvinylidene fluoride) or Celcon^{®*} (acetal copolymer). To order fittings in KYNAR[®] or Celcon[®], call Weatherhead Customer Satisfaction at 1-800-432-6006. Refer to Chemical Resistance Chart, pages 28-32. For detailed information on chemical compatibility, call Weatherhead Technical Support at 1-800-776-3262. General material characteristics are as follows:

Nylon, F.D.A. and N.S.F. listed, has good resistance to organic solvents, oils and gasoline. Good strength at high temperatures. Cold and hot-water applications. Longtime weathering resistance. Good impact resistance, both single and repeated. Not recommended for use with bleach, acids, or chlorine.

Polypropylene, N.S.F. listed, has good chemical resistance. Withstands continuous temperatures up to 215°F (not to exceed temperature specification of tubing). Unaffected by most weak acids, alkalies, alcohols and ketones. Do not use with oxidants or strong acids or in continuous sunlight. 20% glass filled for improved stiffness.

KYNAR[®], an F.D.A. and N.S.F. listed polyvinylidene fluoride, has outstanding chemical resistance for handling highly corrosive fluids.

Celcon[®], an acetal copolymer, N.S.F. listed and U.S.D.A. and F.D.A. listed for coffee, milk and antibiotics, has high tensile strength and good impact resistance over a broad temperature range. Translucent white color. Not affected by continuous hot-water service and works smoothly with metal tubing. Celcon[®] cannot be recommended for continuous exposure to solutions with a chlorine concentration greater than 1 ppm. Suggested maximum continuous-use temperature is 220°F in air and 180°F in water (not to exceed temperature specification of tubing). Unaffected by most inorganics, except sulfuric, nitric and hydrochloric acids. Should not be continuously exposed to sunlight.

Most fittings can be ordered with a GRIPPER style nut. Fittings with a GRIPPER style nut are capable of handling greater pressure than those with standard style nut. See page 131. For ordering fittings with 'GRIPPER' nut, add 'G' to the end of the part number (example: 1568x4x4G or 1568Px4x4G). Some fittings are NOT available with the GRIPPER style nut, while others are ONLY available with the GRIPPER style nut, as noted on page 133-134. For more information, call Weatherhead Technical Support at 1-800-776-3262.

NOTE: It is not necessary to disassemble the fitting for assembly. Merely insert tubing to stop and tighten compression nut.

* Celcon[®] is a registered trademark of Ticona.

** KYNAR[®] is a registered trademark of Elf Atochem North America, Inc.

Molded Compression Tube Fittings

Plastic Fittings

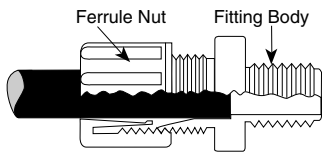

Tube O.D.	1/8 (.125)	1/4 (.250)	5/16 (.312)	3/8 (.375)	1/2 (.500)	5/8 (.625)	3/4 (.750)
Tube Thread Size	5/16-24	7/16-20	1/2-20	5/8-20	3/4-20	7/8-20	1-1/16-20

Male Connector

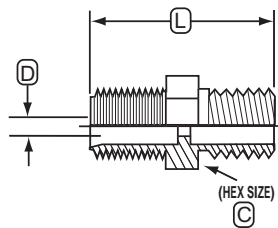

Tube O.D.	Pipe Thread	Male		L	D	Hex C
		Catalog Number Nylon	Catalog Number Polypropylene			
1/8	1/8	1568x2•	1568Px2•	.88	.13	7/16
1/4	1/8	1568x4	1568Px4	.99	.26	5/8
1/4	1/8	1568x4G	1568Px4G	.99	.26	5/8
1/4	1/4	1568x4x4	1568Px4x4	1.17	.26	5/8
1/4	1/4	1568x4x4G	1568Px4x4G	1.17	.26	5/8
1/4	3/8	1568x4x6G [■]	1568Px4x6	1.20	.26	13/16
5/16	1/8	1568x5	1568Px5	1.00	.32	11/16
5/16	1/8	1568x5G	1568Px5G	1.00	.32	11/16
5/16	1/4	1568x5x4	1568Px5x4	1.19	.32	11/16
5/16	1/4	1568x5x4G	1568Px5x4G	1.19	.32	11/16
3/8	1/8	1568x6x2	1568Px6x2	1.14	.38	13/16
3/8	1/8	1568x6x2G	1568Px6x2G	1.14	.38	13/16
3/8	1/4	1568x6	1568Px6	1.30	.38	13/16
3/8	1/4	1568x6G	1568Px6G	1.30	.38	13/16
3/8	3/8	1568x6x6	1568Px6x6	1.34	.38	13/16
3/8	3/8	1568x6x6G	1568Px6x6G	1.34	.38	13/16
3/8	1/2	1568x6x8	1568Px6x8	1.59	.38	59/64
3/8	1/2	1568x6x8G [■]	1568Px6x8G [■]	1.59	.38	59/64
1/2	1/8	1568x8x2G [■]	1568Px8x2G [■]	1.23	.51	15/16
1/2	1/4	1568x8x4	1568Px8x4	1.42	.51	15/16
1/2	1/4	1568x8x4G	1568Px8x4G	1.42	.51	15/16
1/2	3/8	1568x8	1568Px8	1.47	.51	15/16
1/2	3/8	1568x8G	1568Px8G	1.47	.51	15/16
1/2	1/2	1568x8x8	1568Px8x8	1.61	.51	15/16
5/8	3/8	1568x10x6G [■]	1568Px10x6G [■]	1.50	.63	1-1/16
5/8	1/2	1568x10G [■]	1568Px10G [■]	1.66	.63	1-1/16
3/4	3/4	1568x12x12G [■]	1568Px12x12G [■]	1.92	.76	1-5/16

Bulkhead Union

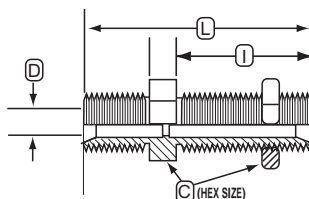

Tube O.D.	Bulkhead Union		L	I	D	Hex C
	Catalog Number Nylon	Catalog Number Polypropylene				
1/4	1574x4	1574Px4	1.45	.88	.26	5/8
1/4	1574x4G	1574Px4G	1.45	.88	.26	5/8
5/16	1574x5	1574Px5	1.63	.98	.32	11/16
5/16	1574x5G	1574Px5G	1.63	.98	.32	11/16
3/8	1574x6	1574Px6	1.78	1.03	.38	13/16
3/8	1574x6G	1574Px6G	1.78	1.03	.38	13/16
1/2	1574x8	1574Px8	1.89	1.04	.51	15/16
1/2	1574x8G	1574Px8G	1.89	1.04	.51	15/16
3/4	1574x12G [■]	1574Px12G [■]	2.41	1.35	.76	1-5/16

• Not available with GRIPPER style nut ■ Sold ONLY with GRIPPER style nut

To order with 'GRIPPER' nut, add 'G' to the end of the part # (Except where noted!) Example: 1568x4x4G or 1568Px4x4G

Union Connector

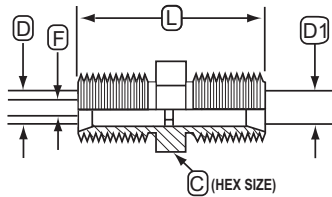

Tube O.D.	Catalog Number Nylon	Catalog Number Polypropylene	L	F	Hex C
1/4	1562x4	1562Px4	.98	.23	5/8
1/4	1562x4G	1562Px4G	.98	.23	5/8
5/16	1562x5	1562Px5	1.03	.28	11/16
5/16	1562x5G	1562Px5G	1.03	.28	11/16
3/8	1562x6	1562Px6	1.23	.30	13/16
3/8	1562x6G	1562Px6G	1.23	.30	13/16
1/2	1562x8	1562Px8	1.44	.48	15/16
1/2	1562x8G	1562Px8G	1.44	.48	15/16
5/8	1562x10G [†]	1562Px10G [†]	1.50	.50	1-1/16
3/4	1562x12G [†]	1562Px12G [†]	1.75	.64	1-5/16

Tube O.D.	Tube O.D.	Catalog Number Nylon	Catalog Number Polypropylene	L	D	Hex C	D1
1/4	1/8	1562x4x2•	1562Px4x2•	.92	.26	5/8	.13
5/16	1/4	1562x5x4•	1562Px5x4G [†]	1.00	.32	11/16	.26
3/8	1/4	1562x6x4	1562Px6x4	1.19	.38	13/16	.26
3/8	1/4	1562x6x4G	1562Px6x4G	1.19	.38	13/16	.26
1/2	3/8	1562x8x6	1562Px8x6	1.33	.51	15/16	.38
1/2	3/8	1562x8x6G	1562Px8x6G	1.33	.51	15/16	.38
5/8	3/8	1562x10x6G [†]	1562Px10x6G [†]	1.34	.63	1-1/16	.38
5/8	1/2	1562x10x8G [†]	1562Px10x8G [†]	1.47	.63	1-1/16	.51

Female Connector

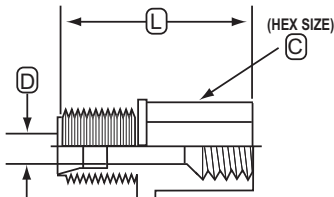

Tube O.D.	Female Pipe Thread	Catalog Number Nylon	Catalog Number Polypropylene	L	D	Hex C
1/4	1/8	1566x4	1566Px4	.92	.23	9/16
1/4	1/8	1566x4G	1566Px4G	.92	.23	9/16
1/4	1/4	1566x4x4	1566Px4x4	1.09	.22	11/16
1/4	1/4	1566x4x4G	1566Px4x4G	1.09	.22	11/16
5/16	1/4	1566x5x4	1566Px5x4	1.22	.28	11/16
5/16	1/4	1566x5x4G	1566Px5x4G	1.22	.28	11/16
3/8	1/4	1566x6	1566Px6	1.20	.36	11/16
3/8	1/4	N/A	1566Px6G	1.20	.36	11/16
3/8	3/8	1566x6x6	1566Px6x6	1.20	.36	13/16
3/8	3/8	1566x6x6G	1566Px6x6G	1.20	.36	13/16
3/8	1/2	1566x6x8	1566Px6x8	1.27	.34	1-3/64
3/8	1/2	1566x6x8G	1566Px6x8G	1.27	.34	1-3/64
1/2	3/8	1566x8	1566Px8	1.23	.47	13/16
1/2	3/8	1566x8G	1566Px8G	1.23	.47	13/16
1/2	1/2	1566x8x8	1566Px8x8	1.30	.48	15/16
1/2	1/2	1566x8x8G	1566Px8x8G	1.30	.48	15/16
5/8	1/2	1566x10G [†]	1566Px10G [†]	1.50	.52	1-1/16

[†]Sold ONLY with GRIPPER style nut

Female Elbow

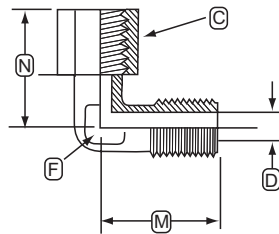

Female		Catalog Number Nylon	Catalog Number Polypropylene	M	N	D	Hex C	Across Flats F
Tube O.D.	Pipe Thread							
1/4	1/8	1570x4	1570Px4	.81	.75	.26	35/64	25/64
1/4	1/8	N/A	1570Px4G	.81	.75	.26	35/64	25/64
1/4	1/4	1570x4x4	1570Px4x4	.81	.97	.26	11/16	13/32
1/4	1/4	N/A	1570Px4x4	.81	.97	.26	11/16	13/32
5/16	1/4	1570x5x4G [■]	1570Px5x4G [■]	.94	1.00	.32	11/16	7/16
3/8	1/4	1570x6	1570Px6	.94	1.02	.38	51/64	37/64
3/8	1/4	N/A	1570Px6G	.94	1.02	.38	51/64	37/64
3/8	3/8	1570x6x6	1570Px6x6	.91	1.03	.38	13/16	9/16
3/8	3/8	N/A	1570Px6x6G	.91	1.03	.38	13/16	9/16
1/2	3/8	1570x8	1570Px8	1.09	1.13	.51	51/64	23/32
1/2	3/8	N/A	1570Px8G	1.09	1.13	.51	51/64	23/32
1/2	1/2	1570x8x8	1570Px8x8	1.09	1.34	.51	15/16	23/32
1/2	1/2	N/A	1570Px8x8G	1.09	1.34	.51	15/16	23/32
5/8	1/2	N/A	1570Px10G [■]	1.38	1.06	.63	1-1/16	53/64

Male Elbow

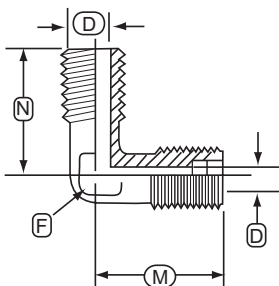

Male		Catalog Number Nylon	Catalog Number Polypropylene	M	N	D	D1	Across Flats F
Tube O.D.	Pipe Thread							
1/8	1/8	1569x2•	1569Px2•	.56	.63	.11	.20	1/4
1/4	1/8	1569x4	1569Px4	.81	.81	.22	.25	3/8
1/4	1/8	1569x4G	1569Px4G	.81	.81	.22	.25	3/8
1/4	1/4	1569x4x4	1569Px4x4	.81	1.02	.22	.28	3/8
1/4	1/4	1569x4x4G	1569Px4x4G	.81	1.02	.22	.28	3/8
1/4	3/8	1569x4x6	1569Px4x6	.84	1.09	.23	.38	9/16
1/4	3/8	1569x4x6G	1569Px4x6G	.84	1.09	.23	.38	9/16
5/16	1/8	1569x5	1569Px5	.89	.906	.30	.25	7/16
5/16	1/8	1569x5G	1569Px5G	.89	.906	.30	.25	7/16
5/16	1/4	1569x5x4	1569Px5x4	.91	1.08	.25	.23	7/16
5/16	1/4	1569x5x4G	1569Px5x4G	.91	1.08	.25	.23	7/16
3/8	1/4	1569x6	1569Px6	.94	1.03	.30	.31	37/64
3/8	1/4	1569x6G	1569Px6G	.94	1.03	.30	.31	37/64
3/8	3/8	1569x6x6	1569Px6x6	.94	1.09	.34	.38	9/16
3/8	3/8	1569x6x6G	1569Px6x6G	.94	1.09	.34	.38	9/16
1/2	1/4	1569x8x4G [■]	1569Px8x4G [■]	1.06	1.09	.39	.31	11/16
1/2	3/8	1569x8	1569Px8	1.09	1.13	.39	.31	11/16
1/2	3/8	1569x8G	1569Px8G	1.09	1.13	.39	.31	11/16
1/2	1/2	1569x8x8	1569Px8x8	1.09	1.28	.47	.36	11/16
1/2	1/2	1569x8x8G	1569Px8x8G	1.09	1.28	.47	.36	11/16
5/8	3/8	1569x10x6G [■]	1569Px10x6G [■]	1.25	1.25	.52	.38	27/32
5/8	1/2	1569x10G [■]	1569Px10G [■]	1.25	1.44	.52	.50	13/16

•Not available with GRIPPER style nut ■Sold ONLY with GRIPPER style nut

Union Tee

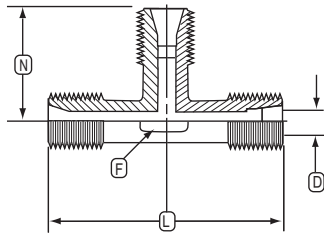

Tube O.D.	Catalog Number Nylon	Catalog Number Polypropylene	L	D	N	Across Flats F
1/8	1564x2•	1564Px2•	1.11	.11	.52	1/4
1/4	1564x4	1564Px4	1.44	.22	.72	23/64
1/4	1564x4G	1564Px4G	1.44	.22	.72	23/64
5/16	1564x5	1564Px5	1.61	.28	.83	7/16
5/16	1564x5G	1564Px5G	1.61	.28	.83	7/16
3/8	1564x6	1564Px6	1.91	.30	.97	17/32
3/8	1564x6G	1564Px6G	1.91	.30	.97	17/32
1/2	1564x8	1564Px8	2.13	.48	1.03	11/16
1/2	1564x8G	1564Px8G	2.13	.48	1.03	11/16
5/8	1564x10G [•]	1564Px10G [•]	2.56	.50	1.25	13/16
3/4	1564x12G [•]	1564Px12G [•]	3.11	.62	1.56	1-1/16
5/8-5/8-3/4	1564x10x10x6G [•]	1564Px10x10x6G [•]	2.53	.50	1.13	3/4

Union Elbow

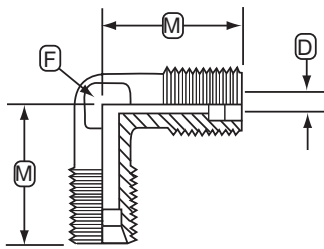

Tube O.D.	Catalog Number Nylon	Catalog Number Polypropylene	M	D	Across Flats F
1/4	1565x4	1565Px4	.81	.22	3/8
1/4	1565x4G	1565Px4G	.81	.22	3/8
5/16	1565x5•	1565Px5G [•]	.91	.30	7/16
3/8	1565x6	1565Px6	.94	.34	9/16
3/8	1565x6G	1565Px6G	.94	.34	9/16
1/2	1565x8	1565Px8	1.06	.39	43/64
1/2	1565x8G	1565Px8G	1.06	.39	43/64
5/8	1565x10G [•]	1565Px10G [•]	1.25	.52	13/16

Male Branch Tee

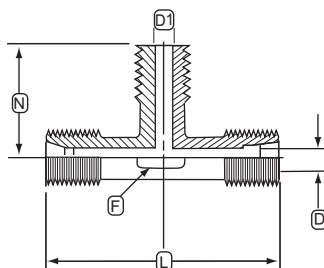

Tube O.D.	Male Pipe Thread	Catalog Number Nylon	Catalog Number Polypropylene	L	D	N	D1	Across Flats F
1/4	1/8	1572x4	1572Px4	1.45	.22	.75	.25	3/8
1/4	1/8	1572x4G	1572Px4G	1.45	.22	.75	.25	3/8
1/4	1/4	1572x4x4x4	1572Px4x4x4G [•]	1.45	.22	.92	.31	3/8
1/4	1/4	1572x4x4x4G	N/A	1.45	.22	.92	.31	3/8
5/16	1/4	1572x5x5x4G [•]	1572Px5x5x4	1.61	.30	.98	.31	27/64
5/16	1/4	N/A	1572Px5x5x4G	1.61	.30	.98	.31	27/64
3/8	1/4	1572x6	1572Px6	1.91	.36	1.06	.31	31/64
3/8	1/4	1572x6G	1572Px6G	1.91	.36	1.06	.31	31/64
3/8	3/8	1572x6x6x6	1572Px6x6x6	1.91	.36	1.11	.38	1/2
3/8	3/8	1572x6x6x6G	1572Px6x6x6G	1.91	.36	1.11	.38	1/2
1/2	3/8	1572x8	1572Px8	2.19	.48	1.16	.38	39/64
1/2	3/8	1572x8G	1572Px8G	2.19	.48	1.16	.38	39/64
1/2	1/2	1572x8x8x8	1572Px8x8x8	2.19	.48	1.31	.48	5/8
1/2	1/2	1572x8x8x8G	1572Px8x8x8G	2.19	.48	1.31	.48	5/8
5/8	1/2	N/A	1572Px10G [•]	2.52	.61	1.44	.47	51/64
3/4	1/2	N/A	1572Px12G [•]	3.09	.64	1.61	.56	1-3/64
3/4	3/4	N/A	1572Px12x12x12G [•]	3.09	.64	1.63	.69	1-3/64

•Not available with GRIPPER style nut •Sold ONLY with GRIPPER style nut

Molded Compression Tube Fittings

Plastic Fittings

Male Run Tee

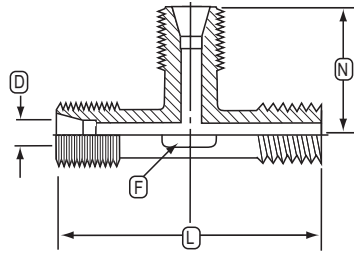

Tube O.D.	Male Pipe Thread	Catalog Number Nylon	Catalog Number Polypropylene	L	D	N	Across Flats F
1/4	1/8	1571x4	1571Px4	1.47	.22	.73	3/8
1/4	1/8	1571x4G	1571Px4G	1.47	.22	.73	3/8
1/4	1/4	1571x4x4x4	1571Px4x4x4	1.67	.22	.72	23/64
1/4	1/4	1571x4x4x4G	1571Px4x4x4G	1.67	.22	.72	23/64
5/16	1/4	1571x5x4x5G [†]	1571Px5x4x5	1.81	.28	.81	7/16
3/8	1/4	1571x6	1571Px6	1.98	.34	.95	31/64
3/8	1/4	1571x6G	1571Px6G	1.98	.34	.95	31/64
3/8	3/8	1571x6x6x6	1571Px6x6x6	2.03	.34	.97	1/2
3/8	3/8	1571x6x6x6G	1571Px6x6x6G	2.03	.34	.97	1/2
1/2	3/8	1571x8	1571Px8	2.27	.47	1.11	5/8
1/2	3/8	1571x8G	1571Px8G	2.27	.47	1.11	5/8
1/2	1/2	1571x8x8x8G [†]	1571Px8x8x8G [†]	2.41	.47	1.11	39/64
5/8	1/2	1571x10G [†]	1571Px10G [†]	2.72	.61	1.25	3/4
3/4	1/2	N/A	1571Px12G [†]	3.17	.64	1.55	1-1/16

Compression Nut

Ferrule Nuts with Integral Sleeve

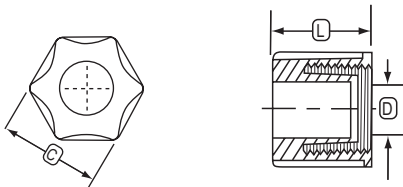

With Plastic Gripper

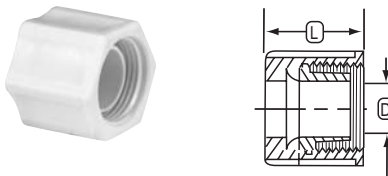

Tube O.D.	Catalog Number Nylon	Catalog Number Polypropylene	Hex C	L	D
1/8	1561x2	1561Px2	7/16	.52	.13
1/4	1561x4	1561Px4	5/8	.63	.26
5/16	1561x5	1561Px5	11/16	.69	.32
3/8	1561x6	1561Px6	13/16	.75	.38
1/2	1561x8	1561Px8	15/16	.88	.51
1/4	1561x4G	1561Px4G	5/8	.69	.26
5/16	1561x5G	1561Px5G	11/16	.75	.32
3/8	1561x6G	1561Px6G	13/16	.73	.38
1/2	1561x8G	1561Px8G	15/16	.88	.51
5/8	1561x10G	1561Px10G	1-1/8	.88	.63

Insert

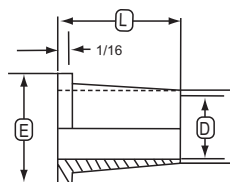

Tube O.D.	Catalog Number Nylon	Catalog Number Polypropylene	E	L	D
1/4	1584x4	1584Px4	.25	.38	.12
5/16	1584x5	1584Px5	.31	.40	.14
3/8	1584x6	1584Px6	.37	.50	.20
1/2	1584x8	1584Px8	.49	.56	.30

PLASTIC

Cap Nut

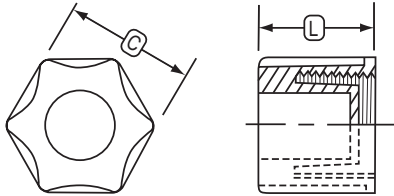

Tube O.D.	Catalog Number Nylon	Catalog Number Polypropylene	L	Hex C
1/8	1529x2	1529Px2	.52	7/16
1/4	1529x4	1529Px4	.63	5/8
5/16	1529x5	1529Px5	.70	45/64
3/8	1529x6	1529Px6	.73	13/16
1/2	1529x8	1529Px8	.88	15/16

Bulkhead Nut

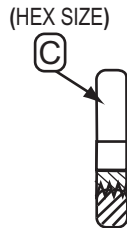

Tube O.D.	Catalog Number Nylon	Catalog Number Polypropylene	Hex C
1/4	1502x4	1502Px4	5/8
5/16	1502x5	1502Px5	11/16
3/8	1502x6	1502Px6	13/16
1/2	1502x8	1502Px8	15/16
3/4	1502x12	1502Px12	1-5/16

KYNAR® Check Valve

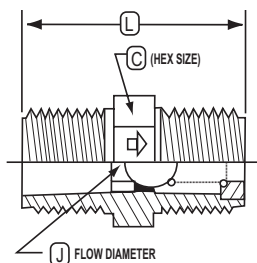

Male Pipe Size N.P.T.F.	Catalog Number KYNAR Only	L	J	Hex C
1/8	1531x2	1.00	.09	7/16
1/4	1531x4	1.41	.19	5/8
3/8	1531x6	1.50	.25	13/16
1/2	1531x8	1.81	.34	15/16

KYNAR® Check Valve features and benefits:**



- Viton® "O" Ring
- Stainless Ball & Spring
- Zero Leakage
- Maximum Operating Temp. 180°F @ 220 PSI
 - Cracking Pressure 1 to 2.5 PSI

** KYNAR® is a registered trademark of Elf Atochem North America, Inc. Viton® is a registered trademark of DuPont Dow Elastomers

Plastic Fittings

Plastic Fittings

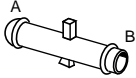
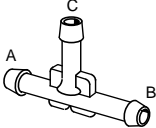
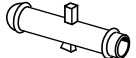
 Refer to safety information regarding tubing selection on page 1.

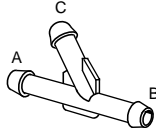
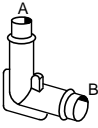
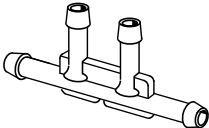
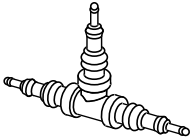
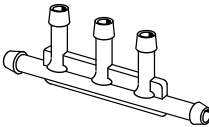
Straight Connector 	<table border="1"> <thead> <tr> <th>Tube I.D. A</th> <th>Tube I.D. B</th> <th>Catalog Number</th> </tr> </thead> <tbody> <tr><td>1/8</td><td>1/8</td><td>1911</td></tr> <tr><td>1/8</td><td>3/16</td><td>1923</td></tr> <tr><td>1/8</td><td>1/4</td><td>1924</td></tr> <tr><td>3/16</td><td>3/16</td><td>1912</td></tr> <tr><td>1/4</td><td>3/16</td><td>1914</td></tr> <tr><td>1/4</td><td>1/4</td><td>1913</td></tr> <tr><td>1/4</td><td>3/8</td><td>1915</td></tr> <tr><td>5/16</td><td>5/16</td><td>1925</td></tr> <tr><td>3/8</td><td>3/8</td><td>1927</td></tr> </tbody> </table>	Tube I.D. A	Tube I.D. B	Catalog Number	1/8	1/8	1911	1/8	3/16	1923	1/8	1/4	1924	3/16	3/16	1912	1/4	3/16	1914	1/4	1/4	1913	1/4	3/8	1915	5/16	5/16	1925	3/8	3/8	1927	3 Way Tee 	<table border="1"> <thead> <tr> <th>Tube I.D. A</th> <th>Tube I.D. B</th> <th>Tube I.D. C</th> <th>Catalog Number</th> </tr> </thead> <tbody> <tr><td>1/8</td><td>1/8</td><td>1/8</td><td>1916</td></tr> <tr><td>1/8</td><td>1/8</td><td>3/16</td><td>1917</td></tr> <tr><td>1/8</td><td>1/8</td><td>1/4</td><td>1918</td></tr> <tr><td>1/8</td><td>3/16</td><td>1/8</td><td>1939</td></tr> <tr><td>3/16</td><td>1/8</td><td>3/16</td><td>1940</td></tr> <tr><td>3/16</td><td>3/16</td><td>3/16</td><td>1902</td></tr> <tr><td>3/16</td><td>3/16</td><td>1/8</td><td>1920</td></tr> <tr><td>3/16</td><td>3/16</td><td>1/4</td><td>1921</td></tr> <tr><td>1/4</td><td>3/16</td><td>3/16</td><td>1942</td></tr> <tr><td>1/4</td><td>1/4</td><td>1/4</td><td>1903</td></tr> <tr><td>1/4</td><td>1/4</td><td>3/16</td><td>1943</td></tr> <tr><td>5/16</td><td>5/16</td><td>5/16</td><td>1906</td></tr> <tr><td>3/8</td><td>3/16</td><td>3/8</td><td>1944</td></tr> <tr><td>3/8</td><td>1/4</td><td>3/8</td><td>1945</td></tr> <tr><td>3/8</td><td>5/16</td><td>3/8</td><td>1946</td></tr> <tr><td>3/8</td><td>3/8</td><td>3/16</td><td>1907</td></tr> <tr><td>3/8</td><td>3/8</td><td>1/4</td><td>1908</td></tr> <tr><td>3/8</td><td>3/8</td><td>3/8</td><td>1922</td></tr> </tbody> </table>	Tube I.D. A	Tube I.D. B	Tube I.D. C	Catalog Number	1/8	1/8	1/8	1916	1/8	1/8	3/16	1917	1/8	1/8	1/4	1918	1/8	3/16	1/8	1939	3/16	1/8	3/16	1940	3/16	3/16	3/16	1902	3/16	3/16	1/8	1920	3/16	3/16	1/4	1921	1/4	3/16	3/16	1942	1/4	1/4	1/4	1903	1/4	1/4	3/16	1943	5/16	5/16	5/16	1906	3/8	3/16	3/8	1944	3/8	1/4	3/8	1945	3/8	5/16	3/8	1946	3/8	3/8	3/16	1907	3/8	3/8	1/4	1908	3/8	3/8	3/8	1922
Tube I.D. A	Tube I.D. B	Catalog Number																																																																																																											
1/8	1/8	1911																																																																																																											
1/8	3/16	1923																																																																																																											
1/8	1/4	1924																																																																																																											
3/16	3/16	1912																																																																																																											
1/4	3/16	1914																																																																																																											
1/4	1/4	1913																																																																																																											
1/4	3/8	1915																																																																																																											
5/16	5/16	1925																																																																																																											
3/8	3/8	1927																																																																																																											
Tube I.D. A	Tube I.D. B	Tube I.D. C	Catalog Number																																																																																																										
1/8	1/8	1/8	1916																																																																																																										
1/8	1/8	3/16	1917																																																																																																										
1/8	1/8	1/4	1918																																																																																																										
1/8	3/16	1/8	1939																																																																																																										
3/16	1/8	3/16	1940																																																																																																										
3/16	3/16	3/16	1902																																																																																																										
3/16	3/16	1/8	1920																																																																																																										
3/16	3/16	1/4	1921																																																																																																										
1/4	3/16	3/16	1942																																																																																																										
1/4	1/4	1/4	1903																																																																																																										
1/4	1/4	3/16	1943																																																																																																										
5/16	5/16	5/16	1906																																																																																																										
3/8	3/16	3/8	1944																																																																																																										
3/8	1/4	3/8	1945																																																																																																										
3/8	5/16	3/8	1946																																																																																																										
3/8	3/8	3/16	1907																																																																																																										
3/8	3/8	1/4	1908																																																																																																										
3/8	3/8	3/8	1922																																																																																																										
Restrictor Connector 	<table border="1"> <thead> <tr> <th>Tube I.D. Size</th> <th>Catalog Number</th> </tr> </thead> <tbody> <tr> <td>3/16</td> <td>1950</td> </tr> </tbody> </table>	Tube I.D. Size	Catalog Number	3/16	1950																																																																																																								
Tube I.D. Size	Catalog Number																																																																																																												
3/16	1950																																																																																																												
Universal Connector 	<table border="1"> <thead> <tr> <th>Tube I.D. Size</th> <th>Catalog Number</th> </tr> </thead> <tbody> <tr> <td>5/32-1/4-3/8</td> <td>1901</td> </tr> </tbody> </table>	Tube I.D. Size	Catalog Number	5/32-1/4-3/8	1901	Y Connector 	<table border="1"> <thead> <tr> <th>Tube I.D. A</th> <th>Tube I.D. B</th> <th>Tube I.D. C</th> <th>Catalog Number</th> </tr> </thead> <tbody> <tr><td>3/16</td><td>3/16</td><td>3/16</td><td>1932</td></tr> <tr><td>1/4</td><td>1/4</td><td>3/16</td><td>1933</td></tr> <tr><td>1/4</td><td>1/4</td><td>1/4</td><td>1935</td></tr> <tr><td>1/4</td><td>3/8</td><td>3/8</td><td>1936</td></tr> <tr><td>5/16</td><td>5/16</td><td>5/16</td><td>1937</td></tr> <tr><td>3/8</td><td>3/8</td><td>3/8</td><td>1938</td></tr> </tbody> </table>	Tube I.D. A	Tube I.D. B	Tube I.D. C	Catalog Number	3/16	3/16	3/16	1932	1/4	1/4	3/16	1933	1/4	1/4	1/4	1935	1/4	3/8	3/8	1936	5/16	5/16	5/16	1937	3/8	3/8	3/8	1938																																																																										
Tube I.D. Size	Catalog Number																																																																																																												
5/32-1/4-3/8	1901																																																																																																												
Tube I.D. A	Tube I.D. B	Tube I.D. C	Catalog Number																																																																																																										
3/16	3/16	3/16	1932																																																																																																										
1/4	1/4	3/16	1933																																																																																																										
1/4	1/4	1/4	1935																																																																																																										
1/4	3/8	3/8	1936																																																																																																										
5/16	5/16	5/16	1937																																																																																																										
3/8	3/8	3/8	1938																																																																																																										
Elbow Connector 	<table border="1"> <thead> <tr> <th>Tube I.D. A</th> <th>Tube I.D. B</th> <th>Catalog Number</th> </tr> </thead> <tbody> <tr><td>1/8</td><td>3/16</td><td>1928</td></tr> <tr><td>3/16</td><td>3/16</td><td>1929</td></tr> <tr><td>3/16</td><td>1/4</td><td>1930</td></tr> <tr><td>1/4</td><td>1/4</td><td>1931</td></tr> </tbody> </table>	Tube I.D. A	Tube I.D. B	Catalog Number	1/8	3/16	1928	3/16	3/16	1929	3/16	1/4	1930	1/4	1/4	1931	4 Way Tee 	<table border="1"> <thead> <tr> <th>Tube I.D. All Ends</th> <th>Catalog Number</th> </tr> </thead> <tbody> <tr> <td>3/16</td> <td>1948</td> </tr> </tbody> </table>	Tube I.D. All Ends	Catalog Number	3/16	1948																																																																																							
Tube I.D. A	Tube I.D. B	Catalog Number																																																																																																											
1/8	3/16	1928																																																																																																											
3/16	3/16	1929																																																																																																											
3/16	1/4	1930																																																																																																											
1/4	1/4	1931																																																																																																											
Tube I.D. All Ends	Catalog Number																																																																																																												
3/16	1948																																																																																																												
Universal Tee 	<table border="1"> <thead> <tr> <th>Tube I.D. Size</th> <th>Catalog Number</th> </tr> </thead> <tbody> <tr> <td>5/32-1/4-3/8</td> <td>1900</td> </tr> </tbody> </table>	Tube I.D. Size	Catalog Number	5/32-1/4-3/8	1900	5 Way Tee 	<table border="1"> <thead> <tr> <th>Tube I.D. All Ends</th> <th>Catalog Number</th> </tr> </thead> <tbody> <tr> <td>3/16</td> <td>1949</td> </tr> </tbody> </table>	Tube I.D. All Ends	Catalog Number	3/16	1949																																																																																																		
Tube I.D. Size	Catalog Number																																																																																																												
5/32-1/4-3/8	1900																																																																																																												
Tube I.D. All Ends	Catalog Number																																																																																																												
3/16	1949																																																																																																												

PLASTIC

Not recommended for fuel line applications. Temperature Range: -40°F to +350°F. Material: Nylon 6/6

Materials

All Weatherhead Fittings are available in a variety of alloys on special order.

Carbon Steel Fittings – are precision machined from AISI 12L14 carbon steel. Shaped fittings such as elbows and tees with a “C” prefix are made from high-density forgings. Shaped fittings with a “TF” prefix are brazed. Straight fittings are from bar stock.

Stainless Steel Fittings – are made from type 316 stainless. Standard Ermeto® flareless sleeves are made from 17-4PH precipitation hardened stainless.

Finishes

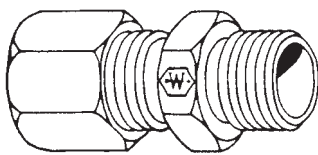

Weathercote™ – is an exclusive Weatherhead® trademark for a protective coating that far exceeds the minimum requirements of the SAE specifications for a corrosion resistant finish for use with petroleum-based, synthetic, and water-based hydraulic fluids. It is readily identified by its dark appearance. Weathercote™ is an amorphous phosphate coating covered with a soluble rust-proof film

resulting in a coating of .0002" thick, yet providing full protection against electrolytic action, thread seizure or corrosive action of hydraulic fluids.

The lubricity of the rust-proof solvent film measurably reduces the amount of torque required to make leak-proof connections.

Zinc Plated – Weatherhead® fittings are given an electrolytic coating .0002" thick minimum.

Stainless Steel – fittings are supplied with natural surface finish except tube nuts which are coated with a bonded dry-film lubricant (black) to reduce assembly torque and prevent galling of threads. All Weatherhead® Stainless Steel Fittings are passivated to remove microscopic foreign particles from the surface of stainless steel as required. Process also leaves a film of corrosion protection.

Hydraulic Fluids

Modern hydraulic systems in use today employ a wide variety of high quality hydraulic fluids. There are three principle types in general use today – each best suited for particular conditions. They are discussed here briefly to clarify the fitting finishes compatible with each type.

Petroleum or Mineral Oil Based

Hydraulic Fluids – are good general purpose fluids available in a full range of viscosity specified as SAE 10, 20, 30, etc. These fluids are not fire resistant, making them unsuitable for use where there is a potential source of ignition. ALL Weatherhead® fittings and O-rings can be used with these fluids.

Straight Synthetic Hydraulic Fluids – is a general term applied to such products as Pydraul, Lindol, Cellulubes 90, 150, 180, 220, etc. used where fire hazards are high. Weathercote™ finish fittings are recommended for this type of fluid. O-rings MUST be made of a “Butyl” compound, or they will “swell” when contacted by synthetic fluids.

Water-Based Hydraulic Fluids – consist generally of a mixture of water and poly-glycols. They are non-flammable and serve the same purpose as the synthetic types. **Only Weathercote™ finish fittings are recommended for this type of fluid.** Zinc plate finishes will be dissolved by water-based fluids and damage to expensive components may result. These water-based fluids are usually less expensive than synthetic fluids and have little or no detrimental effects on Buna-N compounds used in o-rings.

O-Ring Compound and Application Chart

O-Ring Catalog Number	Base Material of Compound	Petroleum & Mineral Oil-Based Hydraulic Fluids	Straight Synthetic Hydraulic Fluids	Water-Based Hydraulic Fluids (Poly-glycols)	Air	Water	Lubricating Oils	Durometer Hardness	Temperature Range °F
4629x*	Buna-N	Excellent	Unsuitable	Good	Excellent	Good	Excellent	90	-40° to +250°
7629x*	Buna-N	Excellent	Unsuitable	Good	Excellent	Good	Excellent	90	-40° to +250°

*Standard O-ring complies with SAE J515 Type CH and ASTM specifications D2000.

All standard Weatherhead® straight thread fittings are supplied with this type O-ring, unless otherwise specified. (Viton O-Rings are available as special order items only).

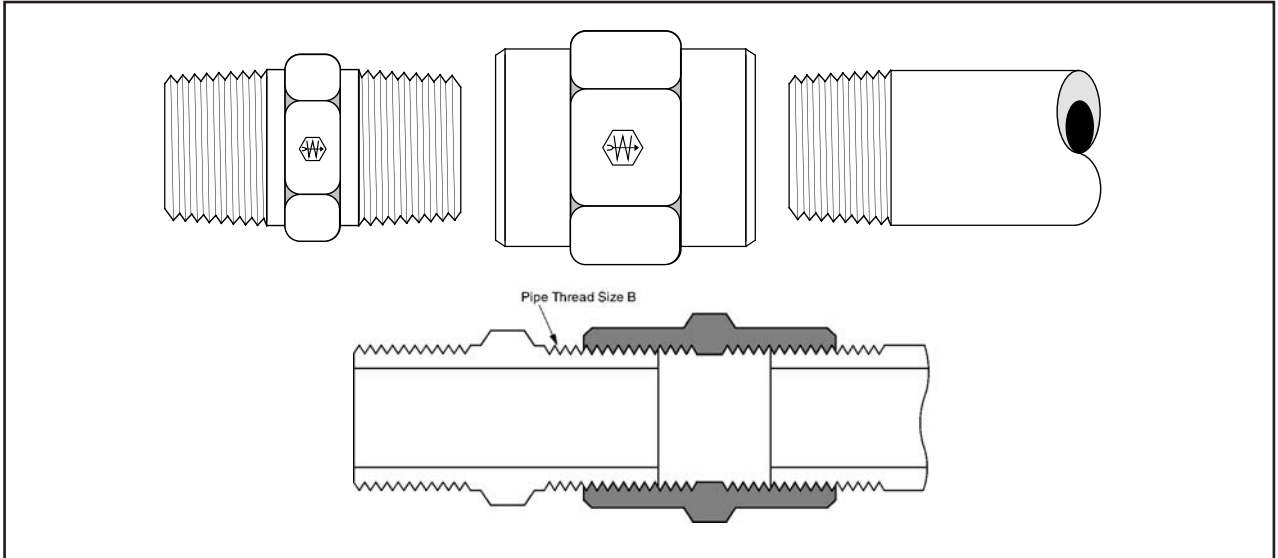

Pipe Size	1/16	1/8	1/4	3/8	1/2	3/4	1	1-1/4	1-1/2	2
Thread Size-B	1/16-27	1/8-27	1/4-18	3/8-18	1/2-14	3/4-14	1-11-1/2	1-1/4-11-1/2	1-1/2-11-1/2	2-11-1/2

Forged Fittings and Adaptors

Pipe Fittings 3000 Series Pressure Rating Chart

Connection Type	End Size								
	1/8"	1/4"	3/8"	1/2"	3/4"	1"	1-1/4"	1-1/2"	2"
Male Pipe (NPTF)	6000	5000	5000	4000	4000	4000	3000	2500	2500
Female Pipe (NPTF)	5000	5000	4000	3000	2500	2000	1500	1500	1000

Brazed Fittings (TF)

Pipe Fittings 3000 Series Pressure Rating Chart

Connection Type	End Size								
	1/8"	1/4"	3/8"	1/2"	3/4"	1"	1-1/4"	1-1/2"	2"
Male Pipe (NPTF)	5000	5000	4000	3000	2500	2000	1150	1000	1000
Female Pipe (NPTF)	5000	5000	4000	3000	2500	2000	1150	1000	1000

Rated pressures are for low surge, static type applications.

- Typical Application**
 Grease, instrumentation and most hydraulic systems.
- Pressure**
 Refer to the pressure charts above. The maximum working pressure of an adapter is the lower working pressure of the end size. Ex: C3069x8x6, 8 = 4000 psi and 6 = 5000 psi. Maximum working pressure is 4000 psi.
- Vibration**
 Fair resistance.
- Temperature Range**
 -65°F to +400°F (-53°C to +204°C).
- Material**
 Carbon Steel - AISI/SAE 12L14
 Stainless Steel - type 316
 Plating - Zinc, yellow dichromate finish ASTM B633 Type II.
- Used With**
 Steel, brass, bronze and iron pipe.
- Advantages**
 Dryseal pipe threads (NPTF) (SAE J476), zinc plate, compact size. Broad range of sizes and styles.
- Conformance**
 Meets SAE specifications.
- How to Order**
 Order individually by catalog number. Example: C3069x4. To order with Weathercote finish (black phosphate coating), use "W" prefix in place of "C". Example: W3069x4 (special order only). To order with pipe sealant (Seal-A-Thread), add a "Z" suffix to the catalog number. Example: C3069x4Z (special order only).

 Weatherhead fittings with a "C" prefix are made from a forged construction. Example: C3609x4. Weatherhead fittings with a "TF" prefix are made from a brazed construction. Example: TF3609x4.
- NOTE**
 Refer to current price list for availability of cataloged items. Quotations and delivery of non-stock items supplied upon request. Configurations and dimensions subject to change without notice. Additional information can be found in SAE J514.
- Assembly Instructions**
 Tighten approximately 2-1/2 turns past finger tight. On all shaped fittings, such as elbows and tees, tighten approximately 2 turns past finger tight and orient the fitting on the third turn. **NOTE:** Backing off for orientation after completing the tightening process, may cause the thread sealing method on these pipe threads to leak!
- Welding procedures**
 Use electric weldrod AWS-E7018. Recommended procedure specifies using lower amperage than usual and puddling of molten metal to permit gases created by lead in steel to work through molten lead deposit.

Label Set: **FS-2000** (adhesive)

Seal-Nut

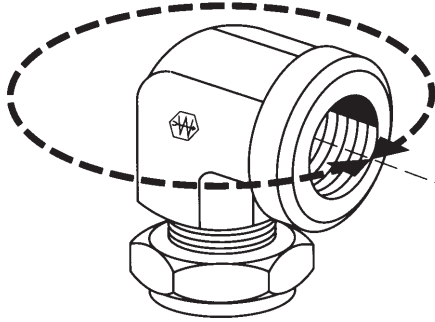

Teflon® is a registered trademark of DuPont.

SPECIFICATIONS FOR "SEAL NUT"

- **Material:** All Weatherhead "Seal-Nuts" are precision machined from 12L14 steel; insert is made of molded virgin Teflon®.
- **Pressure:** Refer to pressure charts on previous page.
- **Temp. Range:** Designed to operate satisfactorily from -100°F to +500°F.
- Makes every pipe connection leakproof.
- Permits positioning of pipe elbows and tees full 360° without overtightening.
- Thread seal-nut on pipe thread. Tighten pipe elbows and tees to proper position, then tighten seal nut for positive seal.
- Eliminates leaks on all pipe threads – Dry Seal or standard. No pipe compound required. Quick, easy installations in cramped quarters where wrench clearance is limited.
- "Seal-Nuts" are an economical substitute for straight thread O-ring boss fittings using original female pipe ports. "Seal-Nuts" give you positive seal on directional fittings like tees and elbows without distorting mounting bosses or damaging expensive valves and pumps.
- **Assembly Instructions:**
 1. Thread Seal-Nut on to the pipe threads until 4 threads protrude beyond the Teflon seal.
 2. Thread fitting a minimum of 3 full threads into port. Continue turning fitting to desired position.
 3. Tighten seal-nut against the port with light to medium torque to provide a positive seal. Torque required will vary with application.

Seal-Nut for Male Pipe Threads

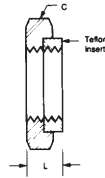

Pipe Thread	Catalog Number	Hex C	L
1/8	C3059x2	5/8	.15
1/4	C3059x4	3/4	.25
3/8	C3059x6	7/8	.25
1/2	C3059x8	1-1/8	.25
3/4	C3059x12	1-5/16	.25
1	C3059x16	1-5/8	.34

Hex Socket Plug

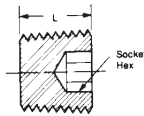
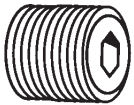

Male Pipe Thread	Catalog Number	Socket Hex	L
1/16	C3169x1	5/32	.31
1/8	C3169x2	3/16	.30
1/4	C3169x4	1/4	.46

Square Head Plug

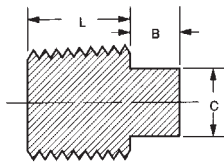
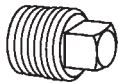

Male Pipe Thread	Catalog Number	B	C	L
1/8	C3179x2	.25	9/32	.34
1/4	C3179x4	.29	3/8	.51
3/8	C3179x6	.32	7/16	.51
1/2	C3179x8	.40	9/16	.68
3/4	C3179x12	.46	5/8	.69
1	C3179x16	.52	13/16	.85

**Hex Head Plug
Stainless Steel No. 3171x**

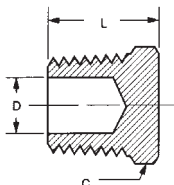
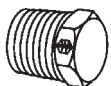

Male Pipe Thread	Catalog Number	Hex C	L	D Opt. Dia.
1/8	C3159x2•	7/16	.56	.156
1/4	C3159x4•	9/16	.68	.250
3/8	C3159x6•	11/16	.78	.375
1/2	C3159x8•	7/8	.98	.500
3/4	C3159x12	1-1/8	1.06	.690
1	C3159x16	1-3/8	1.25	.875
1-1/4	C3159x20	1-3/4	1.56	–
1-1/2	C3159x24	2	1.62	–
2	C3159x32	2-1/2	1.75	–

• Available in stainless steel.

Bushing Stainless Steel No. 3121x (Ref. SAE No. 140140)

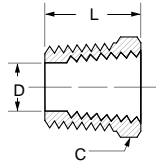
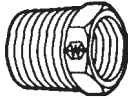

Male Pipe Thread	Female Pipe Thread	Catalog Number	Hex C	D	L
1/4	1/8	C3109x4x2•	5/8	.322	.85
3/8	1/8	C3109x6x2•	3/4	.332	.85
3/8	1/4	C3109x6x4•	3/4	.438	.85
1/2	1/8	C3109x8x2•	7/8	.332	1.10
1/2	1/4	C3109x8x4•	7/8	.438	1.10
1/2	3/8	C3109x8x6•	7/8	.562	1.10
3/4	1/4	C3109x12x4•	1-1/8	.438	1.17
3/4	3/8	C3109x12x6•	1-1/8	.562	1.17
3/4	1/2	C3109x12x8•	1-1/8	.703	1.17
1	3/8	C3109x16x6	1-3/8	.562	1.36
1	1/2	C3109x16x8•	1-3/8	.703	1.36
1	3/4	C3109x16x12•	1-3/8	.922	1.36
1-1/4	1/2	C3109x20x8	1-3/4	.703	1.47
1-1/4	3/4	C3109x20x12•	1-3/4	.922	1.47
1-1/4	1	C3109x20x16•	1-3/4	1.156	1.47
1-1/2	3/4	C3109x24x12	2	.906	1.58
1-1/2	1	C3109x24x16	2	1.141	1.58
1-1/2	1-1/4	C3109x24x20	2	1.500	1.57
2	1-1/4	C3109x32x20	2-1/2	1.484	1.75
2	1-1/2	C3109x32x24	2-1/2	1.719	1.75

Straight Thread O-Ring to Female Pipe Adapter

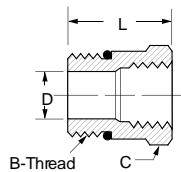
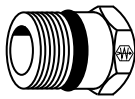

Male Port Size	Female Pipe Thread	Catalog Number	Straight Thread B	Hex C	D	L
1/4	1/8	C3269x4x2	7/16-20	9/16	.172	.97
1/4	1/4	C3269x4x4	7/16-20	3/4	.172	1.16
5/16	1/8	C3269x5x2	1/2-20	5/8	.234	.94
3/8	1/4	C3269x6x4	9/16-18	3/4	.297	1.09
3/8	3/8	C3269x6x6	9/16-18	7/8	.281	1.30
3/8	1/2	C3269x6x8	9/16-18	1-1/8	.281	1.44
1/2	1/4	C3269x8x4	3/4-16	7/8	.421	1.06
1/2	3/8	C3269x8x6	3/4-16	7/8	.421	1.22
1/2	1/2	C3269x8x8	3/4-16	1-1/16	.421	1.50
5/8	1/4	C3269x10x4	7/8-14	1	.422	.81
5/8	3/8	C3269x10x6	7/8-14	1	.500	1.25
5/8	1/2	C3269x10x8	7/8-14	1-1/8	.500	1.50
5/8	3/4	C3269x10x12	7/8-14	1-3/8	.500	1.62
3/4	1/2	C3269x12x8	1-1/16-12	1-1/4	.688	1.34
3/4	3/4	C3269x12x12	1-1/16-12	1-3/8	.656	1.66
7/8	3/4	C3269x14x12	1-3/16-12	1-3/8	.718	1.63
1	1/2	C3269x16x8	1-5/16-12	1-1/2	.688	1.00
1	3/4	C3269x16x12	1-5/16-12	1-1/2	.876	1.50
1	1	C3269x16x16	1-5/16-12	1-5/8	.876	1.88
1-1/4	1	C3269x20x16	1-5/8-12	1-7/8	1.080	1.00
1-1/4	1-1/4	C3269x20x20	1-5/8-12	2	1.080	1.94
1-1/2	1-1/2	C3269x24x24	1-7/8-12	2-3/8	1.312	1.88
2	2	C3269x32x32	2-1/2-12	2-7/8	1.781	1.91

Replacement o-rings page 147.

Adapter Stainless Steel No. 3221x (Ref. SAE 140139)

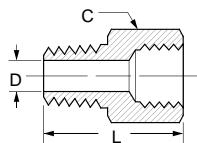
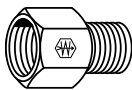

Female Pipe Thread	Male Pipe Thread	Catalog Number	Hex C	D	L
1/4	1/8	C3209x4x2•	3/4	.188	1.21
3/8	1/4	C3209x6x4•	7/8	.281	1.44
1/2	1/8	C3209x8x2•	1-1/8	.188	1.50
1/2	1/4	C3209x8x4•	1-1/8	.281	1.68
1/2	3/8	C3209x8x6•	1-1/8	.406	1.68
3/4	1/4	C3209x12x4•	1-3/8	.281	1.78
3/4	1/2	C3209x12x8•	1-3/8	.531	1.93
1	1/2	C3209x16x8•	1-5/8	.562	2.09
1	3/4	C3209x16x12•	1-5/8	.719	2.18
1-1/4	1	C3209x20x16	2	.938	2.46
1-1/2	1-1/4	C3209x24x20	2-3/8	1.25	2.50
2	1-1/2	C3209x32x24	2-7/8	1.500	2.63

• Available in stainless steel.

Female Straight Thread O-Ring to Male Pipe Adapter

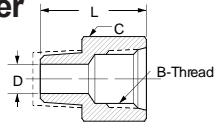
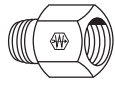

Fem. Port Size	Male Pipe Thread	Catalog Number	Straight Thread B	Hex C	D	L
3/8	3/8	C3239x6x6	9/16-18	13/16	.406	1.38
3/8	1/2	C3239x6x8	9/16-18	7/8	.500	1.61
1/2	3/8	C3239x8x6	3/4-16	1	.406	1.46
1/2	1/2	C3239x8x8	3/4-16	1	.562	1.69
5/8	1/2	C3239x10x8	7/8-14	1-1/4	.531	1.81

Coupling Stainless Steel No. 3321x (Ref. SAE No. 140138)

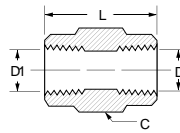
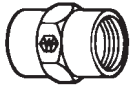

Fem. Pipe Thread	Fem. Pipe Thread	Catalog Number	Hex C	D	D1	L
1/8	1/8	C3309x2•	5/8	.332	.332	.75
1/4	1/8	C3309x4x2•	3/4	.437	.332	1.13
1/4	1/4	C3309x4•	3/4	.437	.437	1.13
3/8	1/4	C3309x6x4•	7/8	.562	.437	1.13
3/8	3/8	C3309x6•	7/8	.562	.562	1.13
1/2	1/4	C3309x8x4•	1-1/8	.687	.437	1.50
1/2	3/8	C3309x8x6•	1-1/8	.687	.562	1.50
1/2	1/2	C3309x8•	1-1/8	.687	.687	1.50
3/4	1/2	C3309x12x8	1-3/8	.906	.687	1.53
3/4	3/4	C3309x12•	1-3/8	.906	.906	1.53
1	3/4	C3309x16x12	1-5/8	1.125	.906	1.89
1	1	C3309x16•	1-5/8	1.125	1.125	1.89
1-1/4	1-1/4	C3309x20	2	1.468	1.468	1.93
1-1/2	1-1/2	C3309x24	2-3/8	1.703	1.703	1.93
2	2	C3309x32	2-7/8	2.188	2.188	1.96

Hex Nipple Stainless Steel No. 3081x (Ref. SAE No. 140137)

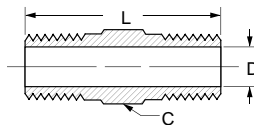

Male Pipe Thread	Male Pipe Thread	Catalog Number	Hex C	D	L
1/16	1/16	C3069x1	5/16	.141	.940
1/8	1/16	C3069x2x1	7/16	.141	.970
1/8	1/8	C3069x2•	7/16	.188	1.06
1/4	1/8	C3069x4x2•	5/8	.188	1.26
1/4	1/4	C3069x4•	5/8	.281	1.45
3/8	1/8	C3069x6x2•	3/4	.188	1.26
3/8	1/4	C3069x6x4•	3/4	.281	1.45
3/8	3/8	C3069x6•	3/4	.406	1.45
1/2	1/4	C3069x8x4•	7/8	.281	1.70
1/2	3/8	C3069x8x6•	7/8	.406	1.70
1/2	1/2	C3069x8•	7/8	.531	1.89
3/4	1/2	C3069x12x8•	1-1/8	.531	1.96
3/4	3/4	C3069x12•	1-1/8	.719	1.96
1	3/4	C3069x16x12	1-3/8	.719	2.16
1	1	C3069x16•	1-3/8	.938	2.34
1-1/4	1-1/4	C3069x20	1-3/4	1.250	2.48
1-1/2	1-1/2	C3069x24	2	1.500	2.61
2	2	C3069x32	2-1/2	1.938	2.83

Male For-Seal® to Male Pipe Adapter

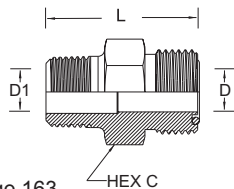
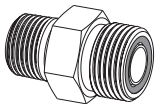

Replacement O-rings page 163.

Tube O.D.	Male Pipe Thread	Catalog Number	Hex C	D	D1	L
3/8	3/8	4205x6x6	3/4	.264	.406	1.30
1/2	3/8	4205x8	7/8	.378	.406	1.45
1/2	1/2	4205x8x8	7/8	.378	.484	1.64
5/8	1/2	4205x10	1-1/16	.484	.531	1.82
3/4	1/2	4205x12x8	1-1/4	.406	.484	1.87
3/4	3/4	4205x12	1-1/4	.609	.719	1.94
3/4	1	4205x12x16	1-3/8	.609	.938	1.87
1	1	4205x16	1-1/2	.811	.938	2.19
1-1/4	1-1/4	4205x20	1-3/4	1.024	1.250	2.30

Male Straight Thread O-Ring to Male Pipe Adapter

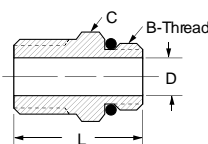

Replacement O-rings page 147.

Male Port Size	Male Pipe Thread	Catalog Number	Straight Thread B	Hex C	D	L
1/4	1/8	C3249x4x2	7/16-20	9/16	.172	1.05
3/8	1/4	C3249x6x4	9/16-18	11/16	.281	1.30
1/2	3/8	C3249x8x6	3/4-16	7/8	.391	1.36
1/2	1/2	C3249x8x8	3/4-16	7/8	.391	1.55
5/8	1/2	C3249x10x8	7/8-14	1	.434	1.69
3/4	3/4	C3249x12x12	1-1/16-12	1-1/4	.609	1.73
1	1	C3249x16x16	1-5/16-12	1-1/2	.844	2.06
1-1/4	1-1/4	C3249x20x20	1-5/8-12	1-7/8	1.078	2.17
1-1/2	1-1/2	C3249x24x24	1-7/8-12	2-1/8	1.312	2.26
2	2	C3249x32x32	2-1/2-12	2-7/8	1.781	2.47

• Available in stainless steel.

Bulkhead Coupling

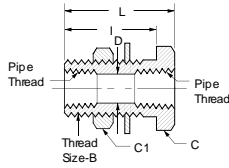
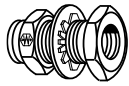

Fem. Pipe Thread	Catalog Number	Thread Size B	Hex C	Hex C1	D	I	L
1/4	W05465	3/4-16	1	15/16	.422	1.25	1.50
1/4	W21204	3/4-16	1	15/16	.422	.69	.94
3/8	W17709	1-14	1-1/8	1-3/8	.563	1.06	1.31

Bulkhead Coupling

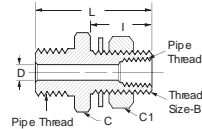
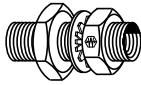

Male Pipe Thread	Fem. Pipe Thread	Catalog Number	Thread Size B	Hex C	Hex C1	D	I	L
1/2	1/4	W05498	3/4-16	1-1/4	1-1/16	.312	1.13	2.16
1/2	1/4	W05499	3/4-16	1-1/4	1-1/16	.312	1.53	2.53

Bulkhead Coupling

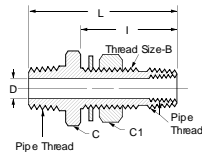
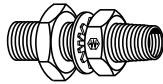

Male Pipe Thread	Fem. Pipe Thread	Catalog Number	Thread Size B	Hex C	Hex C1	D	I	L
1/2	1/4	W05730	1-14	1-1/4	1-3/8	.375	1.91	2.94
1/2	1/4	W23464	1-14	1-1/4	1-3/8	.375	2.88	3.94

45° Female Elbow (Ref. SAE No. 140338)

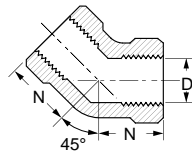
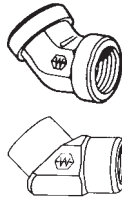

Fem. Pipe Thread	Catalog Number	D	N	Across Flats
1/4	C3559x4	.437	.69	3/4
3/8	C3559x6	.562	.750	7/8
1/2	C3559x8	.687	.940	1-1/16
3/4	C3559x12	.906	1.000	1-5/16
1	C3559x16	1.125	1.190	1-5/8
1/4	TF3559x4	.437	.620	3/4

45° Street Elbow Stainless Steel No. 3371x (Ref. SAE No. 140339)

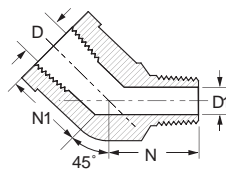
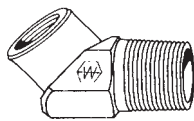
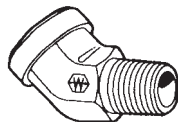

Fem. Pipe Thread	Male Pipe Thread	Catalog Number	D	D1	N1	N	Across Flats
1/8	1/8	C3359x2•	.332	.188	.47	.72	9/16
1/4	1/4	C3359x4•	.437	.281	.62	1.05	3/4
3/8	3/8	C3359x6•	.562	.406	.72	1.10	7/8
1/2	1/2	C3359x8•	.687	.531	.91	1.34	1-1/16
3/4	3/4	C3359x12•	.906	.719	.97	1.38	1-5/16
1	1	C3359x16•	1.125	.938	1.12	1.72	1-5/8
1/8	1/8	TF3359x2	.332	.188	.47	.72	5/8
1/4	1/4	TF3359x4	.437	.281	.62	1.05	3/4
3/8	3/8	TF3359x6	.562	.406	.72	1.10	7/8
1/2	1/2	TF3359x8	.687	.531	.91	1.34	1-1/8
3/4	3/4	TF3359x12	.906	.719	.97	1.38	1-3/8
1	1	TF3359x16	1.125	.938	1.12	1.72	1-5/8
1-1/4	1-1/4	TF3359x20	1.468	1.250	1.63	1.80	2
1-1/2	1-1/2	TF3359x24	1.734	1.500	1.69	2.06	2-3/8
2	2	TF3359x32	2.188	1.938	2.30	2.15	2-1/2

• Available in stainless steel.

90° Female Elbow
Stainless Steel No. **3521x**
(Ref. SAE No. 140238)

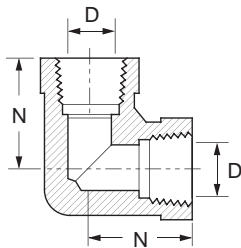
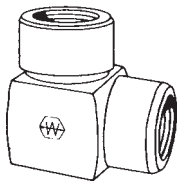

Fem. Pipe Thread	Fem. Pipe Thread	Catalog Number	D	N	Across Flats
1/8	1/8	C3509x2•	.332	.66	9/16
1/4	1/4	C3509x4•	.437	.88	3/4
3/8	3/8	C3509x6•	.562	1.02	7/8
1/2	1/2	C3509x8•	.687	1.23	1-1/16
3/4	3/4	C3509x12•	.906	1.36	1-5/16
1	1	C3509x16	1.125	1.62	1-5/8
1-1/4	1-1/4	C3509x20	1.468	1.70	1-7/8
2	2	C3509x32	2.188	2.39	2-3/16
1/8	1/8	TF3509x2	.332	.66	5/8
1/4	1/8	TF3509x4x2	.343	.88	3/4
1/4	1/4	TF3509x4	.437	.88	3/4
3/8	1/4	TF3509x6x4	.437	1.02	7/8
3/8	3/8	TF3509x6	.562	1.02	7/8
1/2	3/8	TF3509x8x6	.562	1.23	1-1/8
1/2	1/2	TF3509x8	.687	1.23	1-1/8
3/4	1/2	TF3509x12x8	.687	1.23	1-3/8
3/4	3/4	TF3509x12	.906	1.36	1-3/8
1	1	TF3509x16	1.125	1.62	1-5/8
1-1/4	1-1/4	TF3509x20	1.468	1.70	2
1-1/2	1-1/2	TF3509x24	1.734	2.08	2-3/8

90° Street Elbow
Stainless Steel No. **3421x**
(Ref. SAE No. 140239)

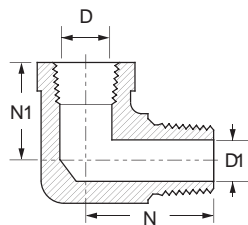
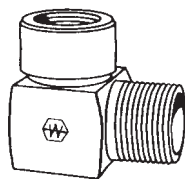
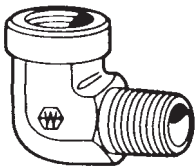

Male Pipe Thread	Fem. Pipe Thread	Catalog Number	D	D1	N	N1	Across Flats
1/8	1/8	C3409x2•	.332	.188	.78	.66	9/16
1/4	1/4	C3409x4•	.437	.281	1.09	.88	3/4
3/8	3/8	C3409x6•	.562	.406	1.22	1.02	7/8
1/2	1/2	C3409x8•	.687	.531	1.47	1.23	1-1/16
3/4	3/4	C3409x12•	.906	.719	1.59	1.36	1-5/16
1	1	C3409x16•	1.125	.938	1.97	1.62	1-5/8
1-1/4	1-1/4	C3409x20	1.468	1.250	2.38	1.70	1-7/8
2	2	C3409x32	2.188	1.930	3.00	2.39	2-13/16
1/8	1/8	TF3409x2	.332	.188	.78	.66	5/8
1/8	1/4	TF3409x2x4	.437	.188	.91	.88	3/4
1/4	1/8	TF3409x4x2	.332	.281	1.09	.67	5/8
1/4	1/4	TF3409x4	.437	.281	1.09	.88	3/4
1/4	3/8	TF3409x4x6	.562	.281	1.22	1.02	7/8
3/8	1/4	TF3409x6x4	.437	.406	1.22	.91	13/16
3/8	3/8	TF3409x6	.562	.406	1.22	1.02	7/8
3/8	1/2	TF3409x6x8	.687	.406	1.38	1.23	1-1/8
1/2	3/8	TF3409x8x6	.562	.531	1.47	1.05	15/16
1/2	1/2	TF3409x8	.687	.531	1.47	1.23	1-1/8
1/2	3/4	TF3409x8x12	.906	.531	1.59	1.23	1-3/8
3/4	1/2	TF3409x12x8	.687	.719	1.59	1.23	1-1/8
3/4	3/4	TF3409x12	.906	.719	1.59	1.36	1-3/8
1	1	TF3409x16	1.125	.938	1.97	1.62	1-5/8
1-1/4	1-1/4	TF3409x20	1.468	1.250	2.38	1.70	2
1-1/2	1-1/2	TF3409x24	1.734	1.500	2.64	2.08	2-3/8

• Available in stainless steel.

90° Straight Thread O-Ring Female Elbow

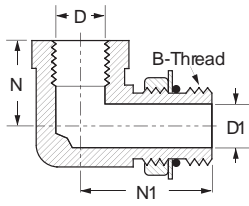
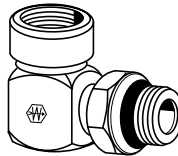
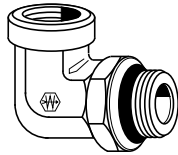

Replacement O-rings page 147.

Male Port Size	Fem. Pipe Thread	Catalog Number	Straight Thread B	D	D1	N	N1	Across Flats
1/2	3/8	C3459x8	3/4-16	.562	.422	.63	1.47	7/8
5/8	1/2	C3459x10	7/8-14	.687	.500	.75	1.81	1-1/16
3/4	3/4	C3459x12	1-1/16-12	.906	.656	.81	2.00	1-5/16
1	1	C3459x16	1-5/16-12	1.125	.876	1.00	2.25	1-5/8
1/4	1/8	TF3459x4	7/16-20	.332	.172	.66	1.09	5/8
5/16	1/8	TF3459x5	1/2-20	.332	.234	.66	1.13	5/8
3/8	1/4	TF3459x6	9/16-18	.437	.297	.88	1.31	3/4
1/2	3/8	TF3459x8	3/4-16	.562	.391	1.02	1.49	7/8
5/8	1/2	TF3459x10	7/8-14	.687	.484	1.23	1.80	1-1/8
3/4	3/4	TF3459x12	1-1/16-12	.906	.609	1.36	2.06	1-3/8
7/8	3/4	TF3459x14	1-3/16-12	.906	.719	1.42	2.06	1-3/8
1	1	TF3459x16	1-5/16-12	1.125	.844	1.62	2.17	1-5/8
1-1/4	1-1/4	TF3459x20	1-5/8-12	1.468	1.078	1.70	2.38	2
1-1/2	1-1/2	TF3459x24	1-7/8-12	1.703	1.312	2.08	2.58	2-3/8
2	2	TF3459x32	2-1/2-12	2.180	1.781	2.39	3.02	2-7/8

90° Straight Thread O-Ring Female Elbow Long

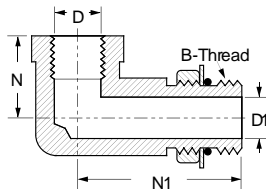
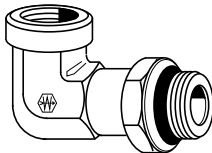

Replacement O-rings page 147.

Male Port Size	Fem. Pipe Thread	Catalog Number	Straight Thread B	D	D1	N	N1	Across Flats
1/2	3/8	C3469x8	3/4-16	.562	.422	.63	2.94	7/8
5/8	1/2	C3469x10	7/8-14	.687	.500	.75	3.56	1-1/16
3/4	3/4	C3469x12	1-1/16-12	.906	.656	.81	4.13	1-5/16
1	1	C3469x16	1-5/16-12	1.125	.876	1.00	4.63	1-5/8

90° Straight Thread O-Ring Male Elbow to Male Pipe

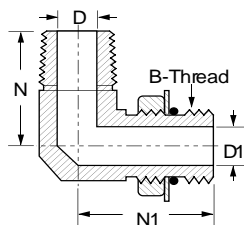
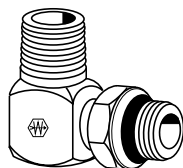

Replacement O-rings page 147.

Male Port Size	Male Pipe Thread	Catalog Number	Straight Thread B	D	D1	N	N1	Across Flats
1/4	1/8	TF3569x4	7/16-20	.172	.188	.78	1.03	1/2
5/16	1/8	TF3569x5	1/2-20	.234	.188	.78	1.09	9/16
3/8	1/4	TF3569x6	9/16-18	.297	.281	1.09	1.25	5/8
1/2	3/8	TF3569x8	3/4-16	.391	.406	1.22	1.45	13/16
5/8	1/2	TF3569x10	7/8-14	.484	.531	1.47	1.70	15/16
3/4	3/4	TF3569x12	1-1/16-12	.609	.719	1.59	1.94	1-1/8
7/8	3/4	TF3569x14	1-3/16-12	.719	.719	1.69	2.00	1-1/4
1	1	TF3569x16	1-5/16-12	.844	.938	1.97	2.05	1-3/8
1-1/4	1-1/4	TF3569x20	1-5/8-12	1.078	1.250	2.38	2.25	1-3/4
1-1/2	1-1/2	TF3569x24	1-7/8-12	1.312	1.500	2.64	2.39	2
2	2	TF3569x32	2-1/2-12	1.781	1.938	3.00	2.89	2-5/8

90° Male Elbow
Stainless Steel No. **3541x**

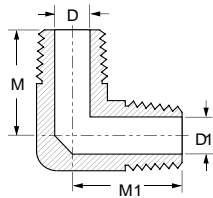
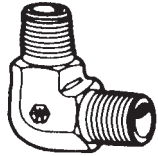

Male Pipe Thread	Male Pipe Thread	Catalog Number	D	D1	M	M1	Across Flats
1/8	1/8	C3529x2	.188	.188	.78	.78	7/16
1/4	1/4	C3529x4	.281	.281	1.09	1.09	9/16
3/8	3/8	C3529x6	.406	.406	1.22	1.22	3/4
1/2	1/2	C3529x8	.531	.531	1.47	1.47	7/8
3/4	3/4	C3529x12	.719	.719	1.59	1.59	1-1/16
1/8	1/8	TF3529x2	.188	.188	.78	.78	1/2
1/4	1/4	TF3529x4	.281	.281	1.09	1.09	5/8
3/8	1/4	TF3529x6x4	.406	.281	1.28	1.19	13/16
3/8	3/8	TF3529x6	.406	.406	1.21	1.21	13/16
1/2	3/8	TF3529x8x6	.531	.406	1.47	1.28	15/16
1/2	1/2	TF3529x8	.531	.531	1.47	1.47	15/16
3/4	1/2	TF3529x12x8	.719	.531	1.59	1.56	1-1/8
3/4	3/4	TF3529x12	.719	.719	1.59	1.59	1-1/8
1	3/4	TF3529x16x12	.938	.719	1.97	1.72	1-3/8
1	1	TF3529x16	.938	.938	1.97	1.97	1-3/8
1-1/4	1-1/4	TF3529x20	1.250	1.250	2.38	2.38	1-3/4
1-1/2	1-1/2	TF3529x24	1.938	1.938	2.64	2.64	2

Tee
Stainless Steel No. **3721x**
(Ref. SAE No. 140438)

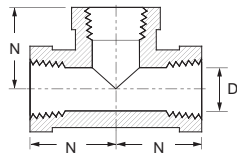
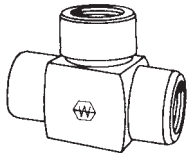
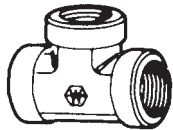

Fem. Pipe Thread	Catalog Number	D	N	Across Flats
1/8	C3709x2	.332	.66	9/16
1/4	C3709x4	.437	.88	3/4
3/8	C3709x6	.562	1.02	7/8
1/2	C3709x8	.687	1.23	1-1/16
3/4	C3709x12	.906	1.36	1-5/16
1	C3709x16	1.125	1.62	1-5/8
1-1/4	C3709x20	1.468	1.70	1-7/8
1/8	TF3709x2	.343	.66	5/8
1/4	TF3709x4	.437	.88	3/4
3/8	TF3709x6	.562	1.02	7/8
1/2	TF3709x8	.687	1.23	1-1/8
3/4	TF3709x12	.906	1.36	1-3/8
1	TF3709x16	1.275	1.62	1-5/8
1-1/4	TF3709x20	1.468	1.70	2
1-1/2	TF3709x24	1.710	2.08	2-3/8
2	TF3709x32	2.180	2.39	2-7/8

Male Branch Tee
Stainless Steel No. **3621x**
(Ref. SAE No. 140425)

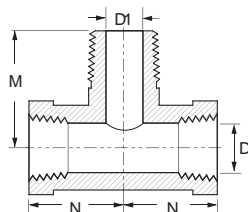
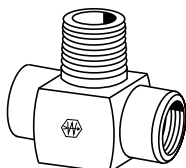
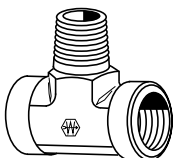

Male Pipe Thread	Fem. Pipe Thread	Catalog Number	D	D1	M	N	Across Flats
1/8	1/8	C3609x2	.332	.188	.78	.66	9/16
1/4	1/4	C3609x4	.437	.281	1.09	.88	3/4
1	1	C3609x16	1.125	.938	1.97	1.62	1-5/8
1/8	1/8	TF3609x2	.343	.188	.78	.66	5/8
1/4	1/4	TF3609x4	.437	.281	1.09	.87	3/4
3/8	3/8	TF3609x6	.562	.406	1.22	1.02	7/8
1/2	1/2	TF3609x8	.687	.531	1.47	1.23	1-1/8
3/4	3/4	TF3609x12	.906	.719	1.59	1.36	1-3/8
1	1	TF3609x16	1.125	.938	1.97	1.62	1-5/8
1-1/4	1-1/4	TF3609x20	1.468	1.250	2.38	1.70	2
1-1/2	1-1/2	TF3609x24	1.700	1.500	2.64	2.08	2-3/8

• Available in stainless steel.

Male Run Tee

Stainless Steel No. 3771x
(Ref. SAE No. 140424)

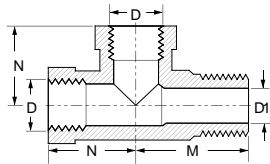
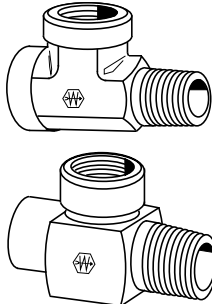

Fem. Pipe Thread	Male Pipe Thread	Catalog Number	D	D1	M	N	Across Flats
1/8	1/8	C3759x2*	.332	.188	.78	.66	9/16
1/4	1/4	C3759x4*	.437	.281	1.09	.88	3/4
3/8	3/8	C3759x6*	.562	.406	1.22	1.02	7/8
1/2	1/2	C3759x8*	.687	.531	1.47	1.23	1-1/16
3/4	3/4	C3759x12	.906	.719	1.59	1.36	1-5/16
1	1	C3759x16	1.125	.938	1.97	1.62	1-5/8
1/8	1/8	TF3759x2	.343	.188	.78	.66	5/8
1/4	1/4	TF3759x4	.437	.281	1.09	.88	3/4
3/8	3/8	TF3759x6	.562	.406	1.22	1.02	7/8
1/2	1/2	TF3759x8	.687	.531	1.47	1.23	1-1/8
3/4	3/4	TF3759x12	.906	.719	1.59	1.36	1-3/8
1	1	TF3759x16	1.125	.938	1.97	1.62	1-5/8
1-1/4	1-1/4	TF3759x20	1.468	1.250	2.38	1.70	2
1-1/2	1-1/2	TF3759x24	1.710	1.500	2.64	2.08	2-3/8
2	2	TF3759x32	2.180	1.938	3.00	2.39	2-7/8

Female Run Tee

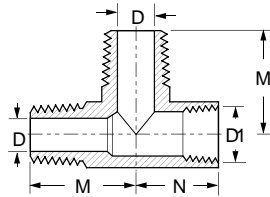
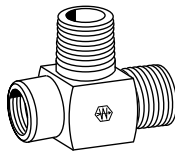

Fem. Pipe Thread	Male Pipe Thread	Catalog Number	D	D1	M	N	Across Flats
1/8	1/8	TF3805x2	.188	.343	.78	.66	5/8
1/4	1/4	TF3805x4	.281	.437	1.09	.88	3/4
3/8	3/8	TF3805x6	.406	.562	1.22	1.02	7/8
1/2	1/2	TF3805x8	.531	.687	1.47	1.23	1-1/8
3/4	3/4	TF3805x12	.719	.906	1.59	1.36	1-3/8
1	1	TF3805x16	.938	1.125	1.97	1.62	1-5/8
1-1/4	1-1/4	TF3805x20	1.250	1.468	2.38	1.70	2
1-1/2	1-1/2	TF3805x24	1.490	2.180	2.64	2.08	2-3/8

Cross

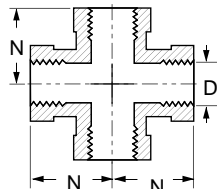
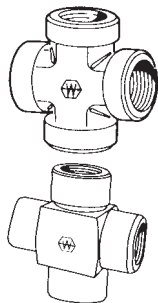

Fem. Pipe Thread	Catalog Number	D	N	Across Flats
3/8	C3959x6	.562	1.02	7/8
1/2	C3959x8	.687	1.23	1-1/16
3/4	C3959x12	.906	1.36	1-5/16
1/8	TF3959x2	.343	.66	5/8
1/4	TF3959x4	.437	.88	3/4
3/8	TF3959x6	.562	1.02	7/8
1/2	TF3959x8	.687	1.23	1-1/8
3/4	TF3959x12	.906	1.36	1-3/8
1	TF3959x16	1.125	1.62	1-5/8
1-1/4	TF3959x20	1.468	1.70	2
1-1/2	TF3959x24	1.710	2.08	2-3/8
2	TF3959x32	2.180	2.39	2-7/8

Straight Thread O-Ring

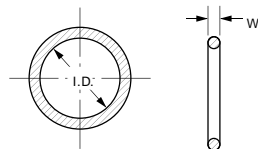

Material: Buna-N, 90 Durometer
Temperature Range: -40°F to +250°F
 (-40°C to +121°C)
 Standard O-ring complies with SAE specification
 SAE J515 Type CH.

Tube O.D.	Catalog Number	W	I.D.
1/16	7629x1	.058	.185
1/8	7629x2	.064	.239
3/16	7629x3	.064	.301
1/4	7629x4	.072	.351
5/16	7629x5	.072	.414
3/8	7629x6	.078	.468
7/16	7629x7	.082	.530
1/2	7629x8	.087	.644
5/8	7629x10	.097	.755
3/4	7629x12	.116	.924
7/8	7629x14	.116	1.048
1	7629x16	.116	1.171
1-1/4	7629x20	.118	1.475
1-1/2	7629x24	.118	1.720
2	7629x32	.118	2.337

• Available in stainless steel.

Typical Application: Pressure hydraulic systems.

Pressure: See chart on this page for pressure ratings.

Sealing Method: Metal to metal, 30° cone-NPSM thread on swivel end.

Material: Carbon steel, AISI/SAE 12L14.

Plating: Zinc, yellow dichromate finish.

Label Set: FS-100 (Adhesive)

9000 Pipe Fittings

Pipe Fittings 9000 Series Pressure Rating Chart

Connection Type	End Size								
	1/8"	1/4"	3/8"	1/2"	3/4"	1"	1-1/4"	1-1/2"	2"
Male Pipe (NPTF)*	5000	5000	4000	3000	2500	2000	1500	1000	1000
Femlae Pipe (NPTF)*	5000	5000	4000	3000	2500	2000	1500	1500	1000

* Pressure ratings shown are the pressure ratings for the fitting and are not necessarily the pressure ratings applicable in an assembly with hydraulic hose. The applicable pressure rating for an assembly with hydraulic hose is the lower value specified for the hose and the fitting unless otherwise agreed to by the supplier and user.

**Female Pipe Swivel to Male Pipe
(Ref. SAE No. 140130)**

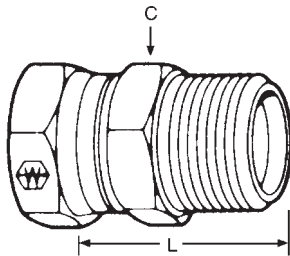

NPSM Swivel Nut	Male Pipe Thread	Catalog Number	Hex C	L
1/8-27	1/8-27	9205x2x2	9/16	.900
1/8-27	1/4-18	9205x2x4	11/16	1.187
1/4-18	1/8-27	9205x4x2	11/16	0.940
1/4-18	1/4-18	9205x4x4	11/16	1.200
1/4-18	3/8-18	9205x4x6	11/16	1.200
1/4-18	1/2-14	9205x4x8	7/8	1.500
3/8-18	1/4-18	9205x6x4	5/8	1.210
3/8-18	3/8-18	9205x6x6	3/4	1.240
3/8-18	1/2-14	9205x6x8	7/8	1.540
1/2-14	3/8-18	9205x8x6	7/8	1.330
1/2-14	1/2-14	9205x8x8	1	1.640
1/2-14	3/4-14	9205x8x12	1-1/4	1.620
3/4-14	1/2-14	9205x12x8	1	1.720
3/4-14	3/4-14	9205x12x12	1-1/4	1.680
3/4-14	1-11-1/2	9205x12x16	1-1/2	1.984
1-11-1/2	3/4-14	9205x16x12	1-1/2	1.800
1-11-1/2	1-11-1/2	9205x16x16	1-1/2	2.010
1-11-1/2	1-1/4-11-1/2	9205x16x20	1-11/16	2.080
1-1/4-11-1/2	1-11-1/2	9205x20x16	1-7/8	2.100
1-1/4-11-1/2	1-1/4-11-1/2	9205x20x20	1-7/8	2.140
1-1/4-11-1/2	1-1/2-11-1/2	9205x20x24	2-1/8	2.187
1-1/2-11-1/2	1-1/4-11-1/2	9205x24x20	2-1/8	2.093
1-1/2-11-1/2	1-1/2-11-1/2	9205x24x24	2-1/8	2.270
2-11-1/2	2-11-1/2	9205x32x32	2-5/8	2.420

**Female JIC 37° Swivel to Male Pipe
Adapter**

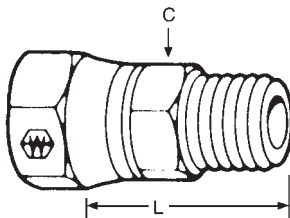

Tube O.D.	Male Pipe Thread	Catalog Number	Hex C	L
1/4	1/4	9100x4x4	9/16	1.130
5/16	1/4	9100x5x4	11/16	1.170
3/8	1/4	9100x6x4	11/16	1.290
3/8	3/8	9100x6x6	11/16	1.290
1/2	3/8	9100x8x6	7/8	1.430
1/2	1/2	9100x8x8	7/8	1.610
5/8	3/8	9100x10x6	1	1.400
5/8	1/2	9100x10x8	1	1.600
3/4	1/2	9100x12x8	1-1/8	1.650
3/4	3/4	9100x12x12	1-1/8	1.650
1	3/4	9100x16x12	1-3/8	1.750
1	1	9100x16x16	1-3/8	1.940
1-1/4	1-1/4	9100x20x20	1-7/8	2.090

NOTE: C and L dimensions subject to change.

Female Pipe Swivel to Female Pipe Straight

(Ref. SAE No. 140131)

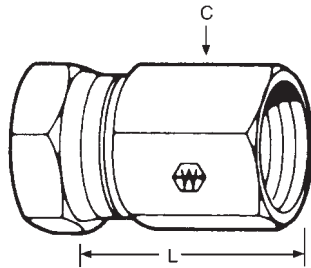

NPSM Swivel Nut	Fem. Pipe Thread	Catalog Number	Hex C	L
1/8-27	1/8-27	9255x2x2	9/16	.880
1/4-18	1/4-18	9255x4x4	11/16	1.170
1/4-18	3/8-18	9255x4x6	7/8	1.312
3/8-18	1/4-18	9255x6x4	11/16	1.250
3/8-18	3/8-18	9255x6x6	7/8	1.310
3/8-18	1/2-14	9255x6x8	1	1.453
1/2-14	3/8-18	9255x8x6	1	1.500
1/2-14	1/2-14	9255x8x8	1	1.500
3/4-14	3/4-14	9255x12x12	1-1/4	1.620
3/4-14	1-11-1/2	9255x12x16	1-1/2	1.906
1-11-1/2	1-11-1/2	9255x16x16	1-1/2	2.000
1-1/4-11-1/2	1-1/4-11-1/2	9255x20x20	1-7/8	2.000
1-1/2-11-1/2	1-1/2-11-1/2	9255x24x24	2-1/8	2.000
2-11-1/2	2-11-1/2	9255x32x32	2-5/8	2.120

Male Straight Thread to Female Pipe Swivel

(Ref. SAE No. 140157)

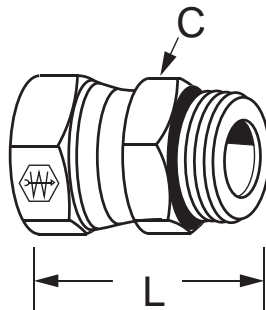

Straight Thread	NPSM Swivel Nut	Catalog Number	Hex C	L
7/16-20	1/4-18	9315x4x4	9/16	.970
7/16-20	3/8-18	9315x4x6	5/8	1.060
1/2-20	1/4-18	9315x5x4	5/8	1.109
9/16-18	1/4-18	9315x6x4	11/16	1.171
9/16-18	3/8-18	9315x6x6	11/16	1.090
9/16-18	1/2-14	9315x6x8	13/16	1.210
3/4-16	1/4-18	9315x8x4	7/8	1.234
3/4-16	3/8-18	9315x8x6	7/8	1.200
3/4-16	1/2-14	9315x8x8	7/8	1.260
3/4-16	3/4-14	9315x8x12	1	1.406
7/8-14	3/8-18	9315x10x6	1	1.375
7/8-14	1/2-14	9315x10x8	1	1.400
7/8-14	3/4-14	9315x10x12	1	1.546
1-1/16-12	1/2-14	9315x12x8	1-1/4	1.453
1-1/16-12	3/4-14	9315x12x12	1-1/4	1.600
1-3/16-12	3/4-14	9315x14x12	1-3/8	1.703
1-5/16-12	3/4-14	9315x16x12	1-1/2	1.734
1-5/16-12	1-11-1/2	9315x16x16	1-1/2	1.710
1-5/8-12	1-11-1/2	9315x20x16	1-7/8	1.828
1-5/8-12	1-1/4-11-1/2	9315x20x20	1-7/8	1.890
1-7/8-12	1-1/2-11-1/2	9315x24x24	2-1/8	1.953
2-1/2-12	2-11-1/2	9315x32x32	2-3/4	2.156

Replacement O-rings page 194.

NOTE: C and L dimensions subject to change.

STEEL

45° Elbow - Female Pipe Swivel to Male Pipe

(Ref. SAE No. 140330)

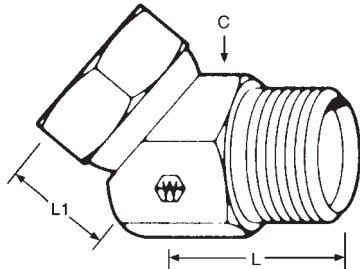

NPSM Swivel Nut	Male Pipe Thread	Catalog Number	Hex		
			C	L	L1
1/8-27	1/8-27	9355x2x2	9/16	.620	.500
1/4-18	1/8-27	9355x4x2	11/16	.660	.470
1/4-18	1/4-18	9355x4x4	11/16	1.020	.670
1/4-18	3/8-18	9355x4x6	7/8	1.060	.620
1/4-18	1/2-14	9355x4x8	1	1.380	.730
3/8-18	1/4-18	9355x6x4	7/8	1.000	.750
3/8-18	3/8-18	9355x6x6	7/8	1.060	.750
3/8-18	1/2-14	9355x6x8	1	1.060	.750
1/2-14	3/8-18	9355x8x6	1	1.310	.910
1/2-14	1/2-14	9355x8x8	1	1.310	.910
1/2-14	3/4-14	9355x8x12	1-1/4	1.31	.910
3/4-14	1/2-14	9355x12x8	1-1/4	1.500	1.000
3/4-14	3/4-14	9355x12x12	1-1/4	1.500	1.000
3/4-14	1-11-1/2	9355x12x16	1-1/2	1.500	1.030
1-11-1/2	3/4-14	9355x16x12	1-1/2	1.310	1.050
1-11-1/2	1-11-1/2	9355x16x16	1-1/2	1.500	1.060
1-11-1/2	1-1/4-11-1/2	9355x16x20	1-7/8	1.800	1.300
1-1/4-11-1/2	1-1/4-11-1/2	9355x20x20	1-7/8	1.750	1.250
1-1/2-11-1/2	1-1/2-11-1/2	9355x24x24	2-1/8	1.940	1.380
2-11-1/2	2-11-1/2	9355x32x32	2-5/8	2.000	1.500

45° Elbow - Female Pipe Swivel to Female Pipe

(Ref. SAE No. 140331)

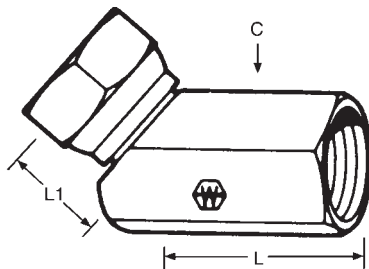

NPSM Swivel Nut	Fem. Pipe Thread	Catalog Number	Hex		
			C	L	L1
1/8-27	1/8-27	9385x2x2	1/2	.620	.500
1/4-18	1/4-18	9385x4x4	11/16	1.020	.670
1/4-18	3/8-18	9385x4x6	7/8	1.062	.625
3/8-18	3/8-18	9385x6x6	7/8	1.060	.750
3/8-18	1/2-14	9385x6x8	1	1.310	.750
1/2-14	1/2-14	9385x8x8	1	1.310	1.270
3/4-14	3/4-14	9385x12x12	1-1/4	1.500	1.000
3/4-14	1-11-1/2	9385x12x16	1-1/2	1.500	1.031
1-11-1/2	1-11-1/2	9385x16x16	1-1/2	1.500	1.000
1-1/4-11-1/2	1-1/4-11-1/2	9385x20x20	1-7/8	1.790	1.250
1-1/2-11-1/2	1-1/2-11-1/2	9385x24x24	2-1/8	1.940	1.380
2-11-1/2	2-11-1/2	9385x32x32	2-5/8	2.000	1.500

45° Elbow - Female SAE 45° Flare Swivel to Male SAE

(Steel)

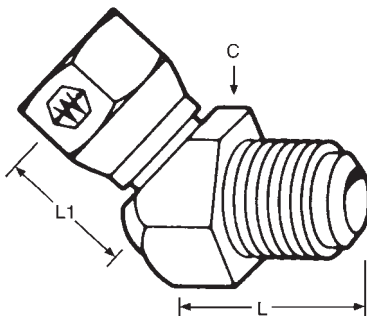

Tube O.D.	Catalog Number	Hex		
		C	L	L1
3/8	9154x6x6	3/4	1.400	.429
1/2	9154x8x8	1	1.760	.598
5/8	9154x10x10	1-1/4	1.920	.645

NOTE: C and L dimensions subject to change.

NPSM Female Swivel Adapters

Steel Fittings

45° Elbow - Male Straight Thread to Female Pipe Swivel (Ref. SAE No. 140357)

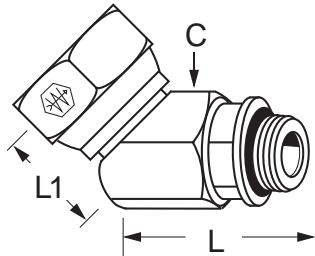

Replacement O-rings page 194.

Straight Thread	NPSM Swivel Nut	Catalog Number	Hex		
			C	L	L1
7/16-20	1/4-18	9365x4x4	11/16	1.062	.656
7/16-20	3/8-18	9365x4x6	7/8	1.062	.656
9/16-18	3/8-18	9365x6x6	7/8	1.062	.703
9/16-18	1/2-14	9365x6x8	1	1.062	.812
3/4-16	3/8-18	9365x8x6	1	1.125	.875
3/4-16	1/2-14	9365x8x8	1	1.125	.812
7/8-14	1/2-14	9365x10x8	1	1.500	.781
1-1/16-12	3/4-14	9365x12x12	1-1/4	1.500	1.046
1-5/16-12	1-11-12	9365x16x16	1-1/2	1.625	1.062
1-5/8-12	1-1/4-11-1/2	9365x20x20	1-7/8	1.281	1.171
1-7/8-12	1-1/2-11-1/2	9365x24x24	2-1/8	1.609	1.343

90° Elbow - Female Pipe Swivel to Male Pipe (Ref. SAE No. 140230)

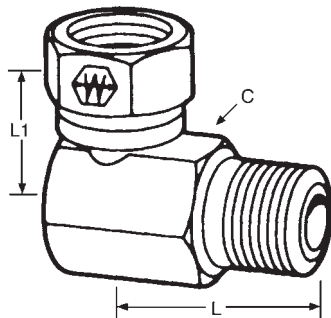

NPSM Swivel Nut	Male Pipe Thread	Catalog Number	Hex		
			C	L	L1
1/8-27	1/8-27	9405x2x2	9/16	.720	.700
1/8-27	1/4-18	9405x2x4	11/16	1.190	.750
1/4-18	1/8-27	9405x4x2	11/16	1.060	.780
1/4-18	1/4-18	9405x4x4	11/16	.980	.750
1/4-18	3/8-18	9405x4x6	11/16	1.500	.810
1/4-18	1/2-14	9405x4x8	1	1.500	.940
3/8-18	1/4-18	9405x6x4	13/16	1.500	.900
3/8-18	3/8-18	9405x6x6	7/8	1.500	.900
3/8-18	1/2-14	9405x6x8	1	1.350	1.020
3/8-18	3/4-14	9405x6x12	1-1/4	2.000	1.120
1/2-14	3/8-18	9405x8x6	1	1.280	1.020
1/2-14	1/2-14	9405x8x8	1	1.810	1.020
1/2-14	3/4-14	9405x8x12	1-1/4	1.490	1.140
1/2-14	1-11-1/2	9405x8x16	1-1/2	2.380	1.250
3/4-14	3/4-14	9405x12x12	1-1/4	1.490	1.200
3/4-14	1-11-1/2	9405x12x16	1-1/2	2.380	1.380
1-11-1/2	3/4-14	9405x16x12	1-1/2	2.190	1.440
1-11-1/2	1-11-1/2	9405x16x16	1-1/2	2.380	1.440
1-11-1/2	1-1/4-11-1/2	9405x16x20	1-7/8	1.578	2.620
1-1/4-11-1/2	1-11 1/2	9405x20x16	1-7/8	2.530	1.660
1-1/4-11-1/2	1-1/4-11-1/2	9405x20x20	1-7/8	2.070	1.630
1-1/4-11-1/2	1-1/2-11-1/2	9405x20x24	2-1/8	2.810	1.780
1-1/2-11-1/2	1-1/2-11-1/2	9405x24x24	2-1/8	2.810	1.750
2-11-1/2	2-11-1/2	9405x32x32	2-5/8	3.120	2.310

90° Elbow Long - Female Pipe Swivel to Male Pipe

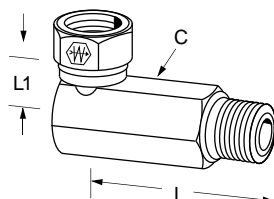

NPSM Swivel Nut	Male Pipe Thread	Catalog Number	Hex		
			C	L	L1
1/8-27	1/8-27	9405X2X2LL	9/16	1.90	.70
1/4-18	1/4-18	9405X4X4LL	11/16	2.57	.75
3/8-18	3/8-18	9405X6X6LL	13/16	3.16	.90
1/2-14	1/2-14	9405X8X8LL	1	3.67	1.02
3/4-14	3/4-14	9405X12X12LL	1-1/4	4.29	1.20
1-11-1/2	1-11-1/2	9405X16X16LL	1-1/2	5.06	1.46

NOTE: C and L dimensions subject to change.

STEEL

90° Elbow - Female Pipe Swivel to Female Pipe

(Ref. SAE No. 140231)

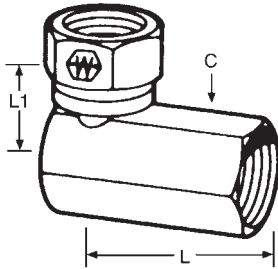

NPSM Swivel Nut	Fem. Pipe Thread	Catalog Number	Hex		
			C	L	L1
1/8-27	1/8-27	9455x2x2	9/16	.640	.700
1/4-18	1/4-18	9455x4x4	11/16	.870	.750
1/4-18	3/8-18	9455x4x6	13/16	1.000	.810
1/4-18	1/2-14	9455x4x8	1	1.250	.940
3/8-18	1/4-18	9455x6x4	13/16	1.000	.900
3/8-18	3/8-18	9455x6x6	13/16	1.000	.900
3/8-18	1/2-14	9455x6x8	1	1.250	1.000
1/2-14	3/8-18	9455x8x6	1	1.220	1.020
1/2-14	1/2-14	9455x8x8	1	1.250	1.000
1/2-14	3/4-14	9455x8x12	1-1/4	1.440	1.120
3/4-14	1/2-14	9455x12x8	1-1/4	1.440	1.250
3/4-14	3/4-14	9455x12x12	1-1/4	1.490	1.200
3/4-14	1-11-1/2	9455x12x16	1-1/2	1.750	1.380
1-11-1/2	3/4-14	9455x16x12	1-1/2	1.750	1.380
1-11-1/2	1-11-1/2	9455x16x16	1-1/2	1.690	1.460
1-1/4-11-1/2	1-1/4-11-1/2	9455x20x20	1-7/8	1.850	1.630
1-1/2-11-1/2	1-1/2-11-1/2	9455x24x24	2-1/8	2.250	1.750
2-11-1/2	2-11-1/2	9455x32x32	2-5/8	2.500	2.310

90° Elbow - SAE 45° Female Swivel to Male SAE 45°

(Steel)

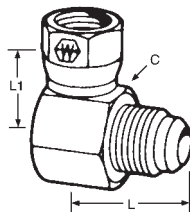

Tube O.D.	Catalog Number	Hex		
		C	L	L1
3/8	9151x6x6	3/4	1.00	.69
1/2	9151x8x8	1	1.25	.99
5/8	9151x10x10	1-1/4	1.44	1.09

90° Elbow - Male Straight Thread to Female Pipe Swivel

(Ref. SAE No. 140257)

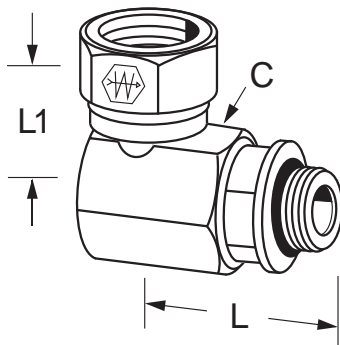

Straight Thread	NPSM Swivel Nut	Catalog Number	Hex		
			C	L	L1
7/16-20	1/4-18	9515x4x4	11/16	1.090	.781
7/16-20	3/8-18	9515x4x6	7/8	1.100	.900
9/16-18	1/4-18	9515x6x4	11/16	1.187	.781
9/16-18	3/8-18	9515x6x6	7/8	1.296	.937
9/16-18	1/2-14	9515x6x8	1	1.484	1.000
3/4-16	3/8-18	9515x8x6	1	1.515	1.000
3/4-16	1/2-14	9515x8x8	1	1.515	1.000
3/4-16	3/4-14	9515x8x12	1-1/4	1.656	1.250
7/8-14	3/8-18	9515x10x6	1	1.640	1.000
7/8-14	1/2-14	9515x10x8	1	1.640	1.025
7/8-14	3/4-14	9515x10x12	1-1/4	1.781	1.250
1-1/16-12	1/2-14	9515x12x8	1-1/4	1.921	1.125
1-1/16-12	3/4-14	9515x12x12	1-1/4	1.921	1.250
1-3/16-12	3/4-14	9515x14x12	1-1/4	1.921	1.250
1-5/16-12	3/4-14	9515x16x12	1-1/2	2.093	1.375
1-5/16-12	1-11-1/2	9515x16x16	1-1/2	2.093	1.390
1-5/8-12	3/4-14	9515x20x12	1-7/8	2.484	1.562
1-5/8-12	1-1/4-11-1/2	9515x20x20	1-7/8	2.484	1.656
1-7/8-12	1-1/2-11-1/2	9515x24x24	2-1/8	2.609	1.734
2-1/2-12	2-11-1/2	9515x32x32	2-5/8	3.250	2.312

Replacement O-rings page 194.

NOTE: C and L dimensions subject to change.

NPSM Female Swivel Adapters

Steel Fittings

90° Elbow - Male Pipe Swivel to Male Pipe Rigid

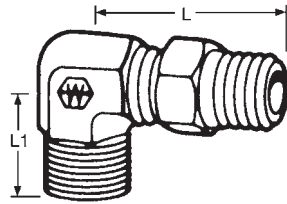

Not for use with liquids over 212°F.

Male Pipe Swivel	Male Pipe	Catalog Number	Hex C	L	L1
1/4-18	1/4-18	9435x4x4	9/16	1.870	1.060
3/8-18	3/8-18	9435x6x6	3/4	1.950	1.220
1/2-14	1/2-14	9435x8x8	7/8	2.250	1.470

Female Pipe Swivel Tee

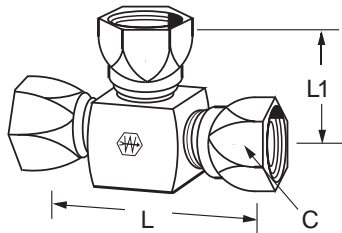

NPSM Swivel Nut	Catalog Number	Across Flats	L	L1	Hex C
1/8-27	9705x2x2x2	1/2	1.406	.660	9/16
1/4-18	9705x4x4x4	11/16	1.720	.780	11/16
3/8-18	9705x6x6x6	7/8	1.720	.940	7/8
1/2-14	9705x8x8x8	1	2.200	1.000	1
3/4-14	9705x12x12x12	1-1/4	2.780	1.250	1-1/4
1-11-1/2	9705x16x16x16	1-1/2	3.060	1.390	1-1/2
1-1/4-11-1/2	9705x20x20x20	1-7/8	3.320	1.660	1-7/8

Female Pipe Swivel to Male Pipe Branch Tee

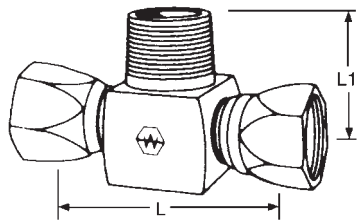

NPSM Swivel Nut	Male Pipe	Catalog Number	Across Flats	L	L1
1/8-27	1/8-27	9406x2x2x2	9/16	1.380	.940
1/4-18	1/4-18	9406x4x4x4	11/16	1.500	1.190
1/4-18	3/8-18	9406x4x4x6	7/8	1.744	1.500
1/4-18	1/2-14	9406x4x4x8	7/8	1.880	1.750
3/8-18	3/8-18	9406x6x6x6	1	1.880	1.750
3/8-18	1/2-14	9406x6x6x8	1	2.000	1.750
1/2-14	1/2-14	9406x8x8x8	1	2.000	1.810
1/2-14	3/4-14	9406x8x8x12	1-1/4	2.250	2.000
3/4-14	3/4-14	9406x12x12x12	1-1/4	2.380	2.000
3/4-14	1-11-1/2	9406x12x12x16	1-1/2	2.756	2.375
1-11-1/2	3/4-14	9406x16x16x12	1-1/2	2.780	2.187
1-11-1/2	1-11-1/2	9406x16x16x16	1-1/2	2.880	2.380
1-1/4-11-1/2	1-1/4-11-1/2	9406x20x20x20	1-7/8	3.240	2.620
1-1/2-11-1/2	1-1/2-11-1/2	9406x24x24x24	2-1/8	3.500	2.810

Female Pipe Swivel to Female Pipe Branch Tee

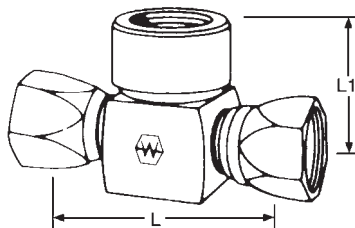

NPSM Swivel Nut	Female Pipe	Catalog Number	Across Flats	L	L1
1/8-27	1/8-27	9456x2x2x2	1/2	1.312	.687
1/4-18	1/4-18	9456x4x4x4	11/16	1.625	.937
1/4-18	3/8-18	9456x4x4x6	7/8	1.744	1.062
3/8-18	3/8-18	9456x6x6x6	7/8	1.874	1.062
3/8-18	1/2-14	9456x6x6x8	1	2.000	1.250
1/2-14	1/2-14	9456x8x8x8	1	2.000	1.250
1/2-14	3/4-14	9456x8x8x12	1-1/4	2.250	1.437
3/4-14	3/4-14	9456x12x12x12	1-1/4	2.500	1.437
3/4-14	1-11-1/2	9456x12x12x16	1-1/2	2.750	1.750
1-11-1/2	1-11-1/2	9456x16x16x16	1-1/2	2.780	1.750
1-1/4-11-1/2	1-1/4-11-1/2	9456x20x20x20	1-7/8	3.312	2.000

NOTE: C and L dimensions subject to change.

STEEL

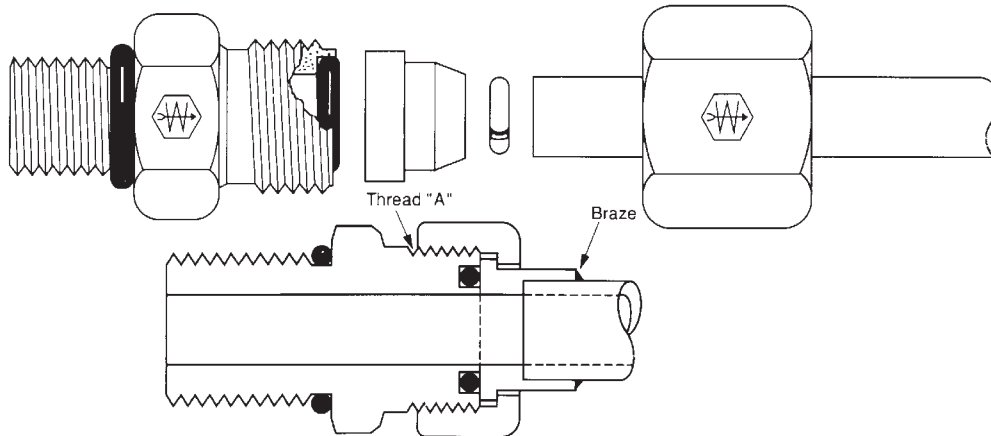

Tube O.D.	1/4	3/8	1/2	5/8	3/4	1	1-1/4	1-1/2
For-Seal Thread	9/16-18	11/16-16	13/16-16	1-14	1-3/16-12	1-7/16-12	1-11/16-12	2-12
Maximum PSI	6000	6000	6000	6000	6000	6000	4000	4000
Adjustable Fittings PSI	6000	6000	6000	6000	6000	5000	4000	3000

Rated pressures are for low surge, static type applications.

- **Typical Application**
High pressure hydraulic, pneumatic and chemical processing.
- **Pressure***
Operating pressure to 6000 psi (1-1/4" and 1-1/2" maximum 4,000 psi). See thread chart.
- **Sealing Method**
Face O-Ring.
- **Vibration**
Excellent resistance.
- **Material**
12L14 Steel.
- **Plating**
All fittings are zinc plated, except braze parts which are oil dipped.
- **Used With**
Steel and stainless steel tubing (tubing for brazing must be non-coated).
- **Advantages**
Tubing is brazed for permanent leakproof connection.
- **Conformance**
Meets SAE J1453.
- **How to Order**
Individually by catalog number. O-Ring supplied with fittings.
- **NOTE**
Refer to current price list for availability of cataloged items. Quotations and delivery of non-stock items supplied on request. Configuration and dimensions subject to change without notice. Additional information can be found in SAE J1453.
- **Assembly Instruction**
See pages 150 & 151. See page 230 & 231 for assembly equipment.
- **Label Set:** **FS-2400** (adhesive)

Torque Requirements

Tube O.D.	1/4	3/8	1/2	5/8	3/4	1	1-1/4	1-1/2
Torque Ft-Lb. For-Seal SW. Nut	10-12	18-20	32-35	46-50	65-70	92 100	125 140	150 165
Torque Ft-Lb O-Ring Boss Straight Thread O-Ring Locknut Torque	14-16	24-26	50-60	72-80	125 135	200 220	210 280	270 360

Tube Preparation And Cleaning

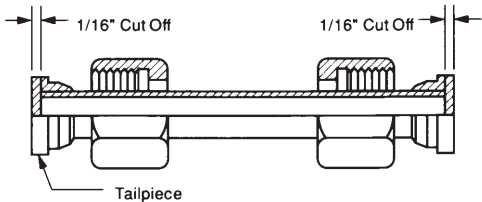

NOTE: Subtract 1/16" from tube length for each connection.

Figure 1

1. Establish the length of tubing required allowing 1/16" cut-off factor for each connection. (See Fig. 1)



2. Cut the tubing to proper length keeping ends reasonably square. A fine tooth hack saw or cut-off saw works well for this job. The use of a tubing cutter is not recommended due to possible collapse of the tube end, retarding the capillary action required for proper braze flow.



3. Clean the end of the tube with an alkaline cleaner to remove all traces of oil or grease. Deburr the end of the tube with a file and polish the outside of the tube down to bare metal with clean emery paper. Oil and grease residue must be removed first to avoid working the oily residue into the tube surface.



4. After polishing, wipe off any metal particles using a clean solvent if necessary. Avoid touching the tube end after final cleaning as this may leave greasy spots which will braze poorly.

Clean the tailpiece with an alkaline cleaner.

Fluxing and Brazing Cleanup

Flux may be cleaned up using hot water and wire brush, using care not to scratch the tailpiece sealing surface.



1. Assemble proper size braze ring into counterbore of tailpiece. The correct size brazing will be slightly smaller than the inside diameter of the counterbore.



2. Clamp the tube securely in a vise, slide nut on tube, with threads pointing outward. Coat the tube end with flux and several inches of the tube outside diameter.



3. Coat the tailpiece liberally with flux including the counterbore and braze ring.



4. In a well ventilated area, apply heat uniformly to the tailpiece and the tube end. Watch the flux. The flux becomes completely clear when it is close to the proper brazing temperature. When ring melts, the tailpiece will settle down onto the end.

NOTE: General working knowledge of Acetylene torch brazing techniques is recommended.



5. Remove tube assembly from vise and check braze joint.



6. The braze alloy will flow down through the joint and should form a continuous fillet at the tube to tailpiece joint.

NOTE: Do not overheat. Excessive heat will only cause scaling and charred flux and make the parts more difficult to clean up.

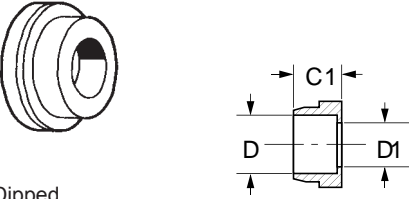
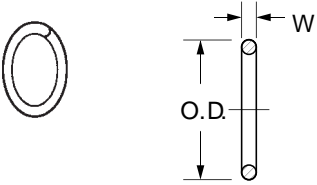
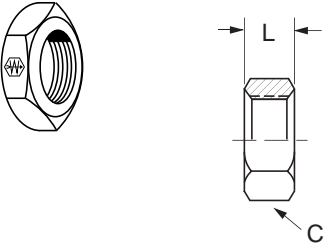
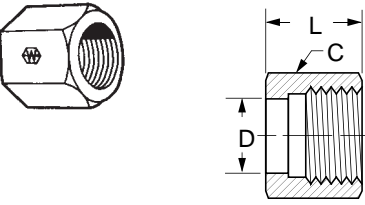
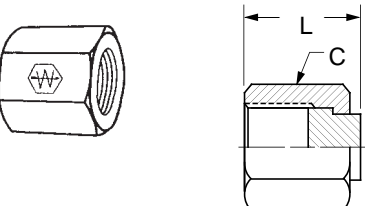
<p>Tailpiece Silver Braze (Ref. SAE No. 520115)</p>  <p>Oil Dipped</p>	<table border="1"> <thead> <tr> <th>Tube O.D.</th> <th>Catalog Number</th> <th>D</th> <th>D1</th> <th>C1</th> </tr> </thead> <tbody> <tr><td>1/4</td><td>4165x4</td><td>.256</td><td>.172</td><td>.374</td></tr> <tr><td>3/8</td><td>4165x6</td><td>.381</td><td>.264</td><td>.374</td></tr> <tr><td>1/2</td><td>4165x8</td><td>.506</td><td>.378</td><td>.374</td></tr> <tr><td>5/8</td><td>4165x10</td><td>.631</td><td>.484</td><td>.413</td></tr> <tr><td>3/4</td><td>4165x12</td><td>.757</td><td>.609</td><td>.551</td></tr> <tr><td>1</td><td>4165x16</td><td>1.007</td><td>.811</td><td>.610</td></tr> <tr><td>1-1/4</td><td>4165x20</td><td>1.257</td><td>1.024</td><td>.610</td></tr> <tr><td>1-1/2</td><td>4165x24</td><td>1.507</td><td>1.260</td><td>.610</td></tr> </tbody> </table>	Tube O.D.	Catalog Number	D	D1	C1	1/4	4165x4	.256	.172	.374	3/8	4165x6	.381	.264	.374	1/2	4165x8	.506	.378	.374	5/8	4165x10	.631	.484	.413	3/4	4165x12	.757	.609	.551	1	4165x16	1.007	.811	.610	1-1/4	4165x20	1.257	1.024	.610	1-1/2	4165x24	1.507	1.260	.610
Tube O.D.	Catalog Number	D	D1	C1																																										
1/4	4165x4	.256	.172	.374																																										
3/8	4165x6	.381	.264	.374																																										
1/2	4165x8	.506	.378	.374																																										
5/8	4165x10	.631	.484	.413																																										
3/4	4165x12	.757	.609	.551																																										
1	4165x16	1.007	.811	.610																																										
1-1/4	4165x20	1.257	1.024	.610																																										
1-1/2	4165x24	1.507	1.260	.610																																										
<p>For-Seal® Cadmium Free Braze Ring</p> 	<table border="1"> <thead> <tr> <th>Tube O.D.</th> <th>Catalog Number</th> <th>Wire Dia.</th> <th>O.D.</th> </tr> </thead> <tbody> <tr><td>1/4</td><td>4640x4</td><td>.046</td><td>.250</td></tr> <tr><td>3/8</td><td>4640x6</td><td>.046</td><td>.375</td></tr> <tr><td>1/2</td><td>4640x8</td><td>.046</td><td>.500</td></tr> <tr><td>5/8</td><td>4640x10</td><td>.046</td><td>.625</td></tr> <tr><td>3/4</td><td>4640x12</td><td>.062</td><td>.750</td></tr> <tr><td>1</td><td>4640x16</td><td>.062</td><td>1.000</td></tr> <tr><td>1-1/4</td><td>4640x20</td><td>.062</td><td>1.250</td></tr> <tr><td>1-1/2</td><td>4640x24</td><td>.062</td><td>1.500</td></tr> </tbody> </table>	Tube O.D.	Catalog Number	Wire Dia.	O.D.	1/4	4640x4	.046	.250	3/8	4640x6	.046	.375	1/2	4640x8	.046	.500	5/8	4640x10	.046	.625	3/4	4640x12	.062	.750	1	4640x16	.062	1.000	1-1/4	4640x20	.062	1.250	1-1/2	4640x24	.062	1.500									
Tube O.D.	Catalog Number	Wire Dia.	O.D.																																											
1/4	4640x4	.046	.250																																											
3/8	4640x6	.046	.375																																											
1/2	4640x8	.046	.500																																											
5/8	4640x10	.046	.625																																											
3/4	4640x12	.062	.750																																											
1	4640x16	.062	1.000																																											
1-1/4	4640x20	.062	1.250																																											
1-1/2	4640x24	.062	1.500																																											
<p>Bulkhead Nut (Ref. SAE No. 520118)</p> 	<table border="1"> <thead> <tr> <th>Tube O.D.</th> <th>Catalog Number</th> <th>Hex C</th> <th>L</th> </tr> </thead> <tbody> <tr><td>1/4</td><td>4924x4</td><td>13/16</td><td>.27</td></tr> <tr><td>3/8</td><td>4924x6</td><td>1</td><td>.31</td></tr> <tr><td>1/2</td><td>4924x8</td><td>1-1/8</td><td>.35</td></tr> <tr><td>5/8</td><td>4924x10</td><td>1-5/16</td><td>.41</td></tr> <tr><td>3/4</td><td>4924x12</td><td>1-1/2</td><td>.41</td></tr> <tr><td>1</td><td>4924x16</td><td>1-3/4</td><td>.41</td></tr> <tr><td>1-1/4</td><td>4924x20</td><td>2</td><td>.41</td></tr> <tr><td>1-1/2</td><td>4924x24</td><td>2-3/8</td><td>.41</td></tr> </tbody> </table>	Tube O.D.	Catalog Number	Hex C	L	1/4	4924x4	13/16	.27	3/8	4924x6	1	.31	1/2	4924x8	1-1/8	.35	5/8	4924x10	1-5/16	.41	3/4	4924x12	1-1/2	.41	1	4924x16	1-3/4	.41	1-1/4	4924x20	2	.41	1-1/2	4924x24	2-3/8	.41									
Tube O.D.	Catalog Number	Hex C	L																																											
1/4	4924x4	13/16	.27																																											
3/8	4924x6	1	.31																																											
1/2	4924x8	1-1/8	.35																																											
5/8	4924x10	1-5/16	.41																																											
3/4	4924x12	1-1/2	.41																																											
1	4924x16	1-3/4	.41																																											
1-1/4	4924x20	2	.41																																											
1-1/2	4924x24	2-3/8	.41																																											
<p>Nut (Ref. SAE No. 520110)</p> 	<table border="1"> <thead> <tr> <th>Tube O.D.</th> <th>Catalog Number</th> <th>Hex C</th> <th>D</th> <th>L</th> </tr> </thead> <tbody> <tr><td>1/4</td><td>4105x4</td><td>11/16</td><td>.412</td><td>.58</td></tr> <tr><td>3/8</td><td>4105x6</td><td>13/16</td><td>.531</td><td>.67</td></tr> <tr><td>1/2</td><td>4105x8</td><td>15/16</td><td>.652</td><td>.83</td></tr> <tr><td>5/8</td><td>4105x10</td><td>1-1/8</td><td>.829</td><td>.93</td></tr> <tr><td>3/4</td><td>4105x12</td><td>1-3/8</td><td>.950</td><td>1.02</td></tr> <tr><td>1</td><td>4105x16</td><td>1-5/8</td><td>1.144</td><td>1.10</td></tr> <tr><td>1-1/4</td><td>4105x20</td><td>1-7/8</td><td>1.415</td><td>1.10</td></tr> <tr><td>1-1/2</td><td>4105x24</td><td>2-1/4</td><td>1.727</td><td>1.10</td></tr> </tbody> </table>	Tube O.D.	Catalog Number	Hex C	D	L	1/4	4105x4	11/16	.412	.58	3/8	4105x6	13/16	.531	.67	1/2	4105x8	15/16	.652	.83	5/8	4105x10	1-1/8	.829	.93	3/4	4105x12	1-3/8	.950	1.02	1	4105x16	1-5/8	1.144	1.10	1-1/4	4105x20	1-7/8	1.415	1.10	1-1/2	4105x24	2-1/4	1.727	1.10
Tube O.D.	Catalog Number	Hex C	D	L																																										
1/4	4105x4	11/16	.412	.58																																										
3/8	4105x6	13/16	.531	.67																																										
1/2	4105x8	15/16	.652	.83																																										
5/8	4105x10	1-1/8	.829	.93																																										
3/4	4105x12	1-3/8	.950	1.02																																										
1	4105x16	1-5/8	1.144	1.10																																										
1-1/4	4105x20	1-7/8	1.415	1.10																																										
1-1/2	4105x24	2-1/4	1.727	1.10																																										
<p>Cap (Ref. SAE No. 520112)</p> 	<table border="1"> <thead> <tr> <th>Tube O.D.</th> <th>Catalog Number</th> <th>Hex C</th> <th>L</th> </tr> </thead> <tbody> <tr><td>1/4</td><td>4129x4</td><td>11/16</td><td>.67</td></tr> <tr><td>3/8</td><td>4129x6</td><td>13/16</td><td>.75</td></tr> <tr><td>1/2</td><td>4129x8</td><td>15/16</td><td>.90</td></tr> <tr><td>5/8</td><td>4129x10</td><td>1-1/8</td><td>1.00</td></tr> <tr><td>3/4</td><td>4129x12</td><td>1-3/8</td><td>1.10</td></tr> <tr><td>1</td><td>4129x16</td><td>1-5/8</td><td>1.17</td></tr> <tr><td>1-1/4</td><td>4129x20</td><td>1-7/8</td><td>1.17</td></tr> <tr><td>1-1/2</td><td>4129x24</td><td>2-1/4</td><td>1.17</td></tr> </tbody> </table>	Tube O.D.	Catalog Number	Hex C	L	1/4	4129x4	11/16	.67	3/8	4129x6	13/16	.75	1/2	4129x8	15/16	.90	5/8	4129x10	1-1/8	1.00	3/4	4129x12	1-3/8	1.10	1	4129x16	1-5/8	1.17	1-1/4	4129x20	1-7/8	1.17	1-1/2	4129x24	2-1/4	1.17									
Tube O.D.	Catalog Number	Hex C	L																																											
1/4	4129x4	11/16	.67																																											
3/8	4129x6	13/16	.75																																											
1/2	4129x8	15/16	.90																																											
5/8	4129x10	1-1/8	1.00																																											
3/4	4129x12	1-3/8	1.10																																											
1	4129x16	1-5/8	1.17																																											
1-1/4	4129x20	1-7/8	1.17																																											
1-1/2	4129x24	2-1/4	1.17																																											

Plug
(Ref. SAE No. 520109)

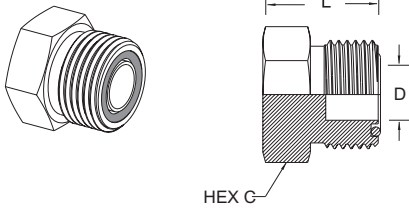

Tube O.D.	Catalog Number	Hex C	D	L
1/4	4229x4	5/8	.172	.659
3/8	4229x6	3/4	.264	.751
1/2	4229x8	7/8	.378	.854
5/8	4229x10	1-1/16	.484	1.020
3/4	4229x12	1-1/4	.609	1.080
1	4229x16	1-1/2	.811	1.100
1-1/4	4229x20	1-3/4	1.024	1.100
1-1/2	4229x24	2-1/8	1.260	1.100

Union
(Ref. SAE No. 520101)

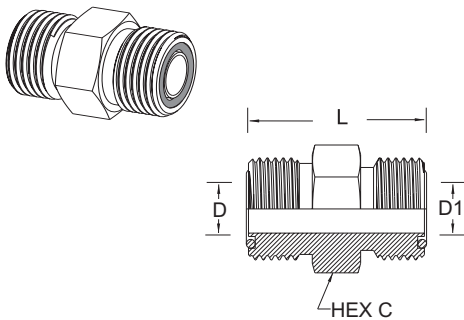

Tube O.D.	Tube O.D.	Catalog Number	Hex C	D	D1	L
1/4	1/4	4305x4	5/8	.172	.172	1.08
3/8	1/4	4305x6x4	3/4	.264	.172	1.17
3/8	3/8	4305x6	3/4	.264	.264	1.22
1/2	3/8	4305x8x6	7/8	.378	.264	1.33
1/2	1/2	4305x8	7/8	.378	.378	1.39
5/8	1/2	4305x10x8	1-1/16	.484	.378	1.57
5/8	5/8	4305x10	1-1/16	.484	.484	1.68
3/4	1/2	4305x12x8	1-1/4	.609	.378	1.69
3/4	5/8	4305x12x10	1-1/4	.609	.484	1.80
3/4	3/4	4305x12	1-1/4	.609	.609	1.86
1	3/4	4305x16x12	1-1/2	.812	.609	1.92
1	1	4305x16	1-1/2	.811	.811	1.94
1-1/4	1-1/4	4305x20	1-3/4	1.024	1.024	2.02
1-1/2	1-1/2	4305x24	2-1/8	1.260	1.260	2.09

Bulkhead Union
(Ref. SAE No. 520601)

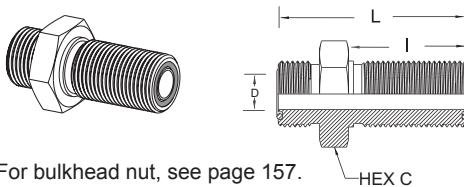

For bulkhead nut, see page 157.

Tube O.D.	Catalog Number	Hex C	D	I	L
3/8	4325x6	1	.264	1.34	2.09
1/2	4325x8	1-1/8	.378	1.44	2.30
3/4	4325x12	1-1/2	.609	1.64	2.72
1	4325x16	1-3/4	.812	1.66	2.76
1-1/4	4325x20	2	1.024	1.66	2.76
1-1/2	4325x24	2-3/8	1.260	1.66	2.76

Straight Thread O-Ring Connector
(Ref. SAE No. 520120)

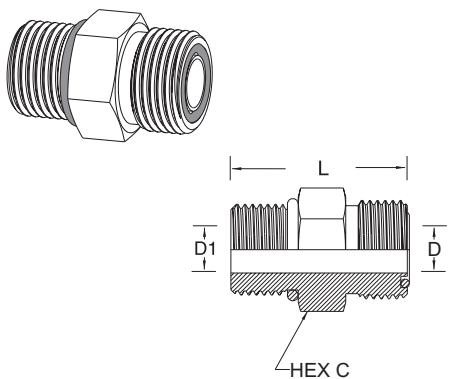

For replacement Straight Thread O-ring, see page 147.

Tube O.D.	Port Size	Catalog Number	Hex C	D	D1	L
1/4	1/4	4315x4	5/8	.172	.172	1.133
1/4	3/8	4315x4x6	11/16	.172	.172	1.202
3/8	1/4	4315x6x4	3/4	.264	.172	1.343
3/8	3/8	4315x6	3/4	.264	.264	1.252
3/8	1/2	4315x6x8	7/8	.378	.264	1.378
3/8	5/8	4315x6x10	1-1/16	.264	.484	1.530
1/2	3/8	4315x8x6	7/8	.378	.264	1.472
1/2	1/2	4315x8	7/8	.378	.378	1.441
1/2	5/8	4315x8x10	1	.378	.484	1.590
1/2	3/4	4315x8x12	1-1/4	.378	.609	1.748
5/8	5/8	4315x10	1-1/16	.484	.484	1.700
3/4	3/4	4315x12	1-1/4	.609	.609	1.918
3/4	1	4315x12x16	1-1/2	.609	.609	1.960
1	3/4	4315x16x12	1-1/2	.812	.609	2.138
1	1	4315x16	1-1/2	.811	.811	1.978
1	1-1/4	4315x16x20	1-7/8	.812	1.709	2.058
1-1/4	1	4315x20x16	1-3/4	1.024	.843	2.278
1-1/4	1-1/4	4315x20	1-7/8	1.024	1.024	2.058
1-1/2	1-1/2	4315x24	2-1/8	1.260	1.260	2.125

Straight Thread O-Ring to Male For-Seal® Extended (Ref. SAE No. 520122)

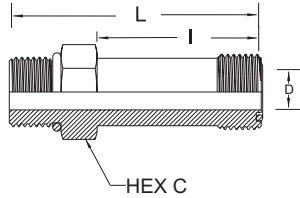
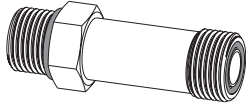

For replacement Straight Thread O-ring, see page 147.

Tube O.D.	Port Size	Catalog Number	Hex C	D	I	L
3/8	3/8	4316x6	3/4	.264	1.46	2.27
1/2	1/2	4316x8	7/8	.378	1.75	2.67
3/4	3/4	4316x12	1-1/4	.609	2.52	3.76
1	1	4316x16	1-1/2	.811	2.87	4.14
1-1/4	1-1/4	4316x20	1-7/8	1.024	3.41	4.76
1-1/2	1-1/2	4316x24	2-1/8	1.260	3.82	5.26

Male JIC 37° to Female Swivel For-Seal®

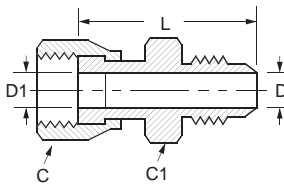
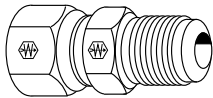

Female Tube O.D.	Male Tube Size	Catalog Number	Hex C	Hex C1	D	D1	L
1/4	1/4	4213x4	11/16	5/8	.172	.165	1.50
3/8	3/8	4213x6	13/16	3/4	.297	.264	1.62
1/2	1/2	4213x8	15/16	7/8	.392	.358	1.90
5/8	5/8	4213x10	1-1/8	1-1/16	.484	.453	2.25
3/4	3/4	4213x12	1-3/8	1-1/4	.609	.547	2.48
1	1	4213x16	1-5/8	1-1/2	.811	.783	2.84

Male Connector

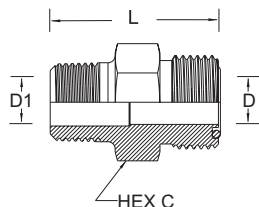
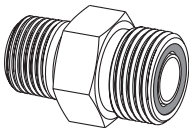

Tube O.D.	Male Pipe Thread	Catalog Number	Hex C	D	D1	L
3/8	3/8	4205x6x6	3/4	.264	.406	1.30
1/2	3/8	4205x8	7/8	.378	.406	1.45
1/2	1/2	4205x8x8	7/8	.378	.484	1.64
5/8	1/2	4205x10	1-1/16	.484	.531	1.82
3/4	1/2	4205x12x8	1-1/4	.406	.484	1.87
3/4	3/4	4205x12	1-1/4	.609	.719	1.94
3/4	1	4205x12x16	1-3/8	.609	.938	1.87
1	1	4205x16	1-1/2	.811	.938	2.19
1-1/4	1-1/4	4205x20	1-3/4	1.024	1.250	2.30

45° Male Elbow

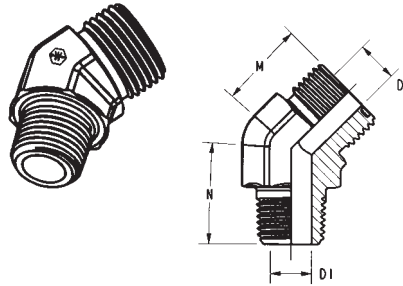

Tube O.D.	Male Pipe Thread	Catalog Number	D	D1	M	N	Across Flats
1/4	1/8	4355x4	.172	.188	.63	.64	9/16
3/8	1/4	4355x6	.264	.281	.74	.86	3/4
1/2	3/8	4355x8	.378	.406	.80	.95	7/8
5/8	1/2	4355x10	.484	.531	.92	1.17	1-1/16
3/4	3/4	4355x12	.609	.719	1.02	1.20	1-5/16
1	1	4355x16	.812	.939	1.18	1.48	1-5/8
1-1/4	1-1/4	4355x20	1.026	1.252	1.26	1.67	1-5/8
1-1/2	1-1/2	4355x24	1.262	1.502	1.45	1.77	1-7/8

45° Elbow - For-Seal® to Straight Thread O-Ring
(Ref. SAE No. 520320)

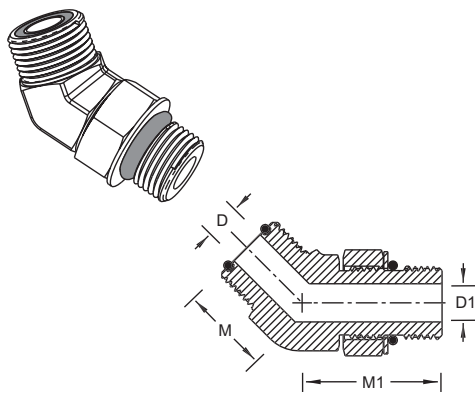

For replacement straight thread O-ring, see page 147.

Tube O.D.	Port Size	Catalog Number	D	D1	M	M1	Across Flats
1/4	1/4	4365x4	.172	.172	.63	1.18	9/16
1/4	3/8	4365x4x6	.172	.264	.68	1.30	3/4
3/8	1/4	4365x6x4	.264	.172	.74	1.22	3/4
3/8	3/8	4365x6	.264	.264	.74	1.30	3/4
3/8	1/2	4365x6x8	.264	.390	.74	1.43	3/4
1/2	3/8	4365x8x6	.378	.264	.80	1.27	3/4
1/2	1/2	4365x8	.378	.390	.80	1.43	3/4
1/2	5/8	4365x8x10	.378	.484	.82	1.76	1-1/16
1/2	3/4	4365x8x12	.378	.609	.87	1.97	1-3/16
5/8	1/2	4365x10x8	.484	.390	.92	1.59	1-1/16
5/8	5/8	4365x10	.484	.484	.92	1.76	1-1/16
5/8	3/4	4365x10x12	.484	.609	.94	1.97	1-3/16
3/4	5/8	4365x12x10	.609	.484	1.02	1.81	1-3/16
3/4	3/4	4365x12	.609	.609	1.02	1.97	1-5/16
3/4	1	4365x12x16	.609	.811	1.16	2.06	1-5/16
1	3/4	4365x16x12	.811	.609	1.12	2.03	1-7/16
1	1	4365x16	.812	.811	1.18	2.06	1-1/2
1	1-1/4	4365x16x20	.811	1.081	1.26	2.11	1-5/8
1-1/4	1-1/4	4365x20	1.024	1.081	1.26	2.11	1-5/8
1-1/2	1-1/2	4365x24	1.260	1.312	1.45	2.11	1-7/8

45° Bulkhead Elbow
(Ref. SAE No. 520801)

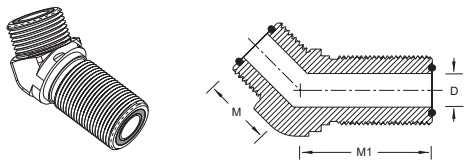

For Bulkhead Nut, see page 157.

Tube O.D.	Catalog Number	D	M	M1	Across Flats
1/4	4375x4	.172	.63	1.73	9/16
3/8	4375x6	.264	.74	1.91	3/4
1/2	4375x8	.378	.80	2.01	3/4
5/8	4375x10	.484	.92	2.23	1-1/16
3/4	4375x12	.609	1.02	2.39	1-3/16
1	4375x16	.811	1.18	2.57	1-7/16
1-1/4	4375x20	1.045	1.26	2.64	1-11/16
1-1/2	4375x24	1.312	1.45	2.64	1-7/8

90° Union Elbow
(Ref. SAE No. 520201)

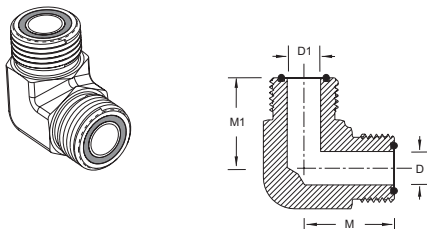

Tube O.D.	Tube O.D.	Catalog Number	D	D1	M	M1	Across Flats
1/4	1/4	4505x4	.172	.172	.85	.85	9/16
1/4	3/8	4505x4x6	.172	.264	.92	.98	3/4
3/8	3/8	4505x6	.264	.264	.98	.98	3/4
1/2	1/2	4505x8	.378	.378	1.10	1.10	3/4
5/8	5/8	4505x10	.484	.484	1.31	1.31	1-1/16
3/4	3/4	4505x12	.609	.609	1.47	1.47	1-3/16
1	1	4505x16	.811	.811	1.64	1.64	1-7/16
1-1/4	1-1/4	4505x20	1.045	1.045	1.76	1.76	1-5/8
1-1/2	1-1/2	4505x24	1.312	1.312	1.92	1.92	1-7/8

90° Elbow - Bulkhead Union (Ref. SAE No. 520701)

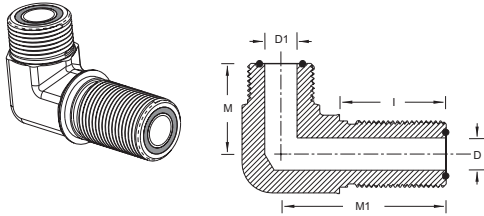

For bulkhead nut, see page 157.

Tube O.D.	Tube O.D.	Catalog Number	D	D1	M	M1	I	Across Flats
1/4	1/4	4525x4	.172	.172	.89	1.85	1.24	9/16
3/8	3/8	4525x6	.264	.264	1.02	2.05	1.34	3/4
1/2	1/2	4525x8	.378	.378	1.14	2.18	1.44	7/8
1/2	5/8	4525x8x10	.484	.378	1.26	2.48	1.60	1-1/16
5/8	5/8	4525x10	.484	.484	1.36	1.36	1.44	1-1/16
3/4	3/4	4525x12	.609	.609	1.52	2.64	1.60	1-5/16
1	1	4525x16	.811	.811	1.67	2.80	1.64	1-5/8
1-1/4	1-1/4	4525x20	1.024	1.024	1.79	2.97	1.66	1-7/8
1-1/2	1-1/2	4525x24	1.260	1.260	1.95	3.13	1.66	1-7/8

90° Male Connector

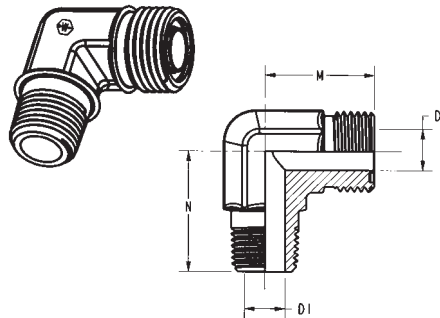

Tube O.D.	Male Pipe	Catalog Number	D	D1	M	N	Across Flats
1/4	1/8	4405x4	.172	.188	.85	.78	9/16
3/8	1/4	4405x6	.264	.281	.80	1.09	3/4
1/2	3/8	4405x8	.378	.406	1.10	1.22	3/4
5/8	1/2	4405x10	.484	.531	1.31	1.47	1-1/16
3/4	3/4	4405x12	.609	.719	1.47	1.59	1-5/16
1	1	4405x16	.812	.939	1.64	1.97	1-5/8
1-1/4	1-1/4	4405x20	1.026	1.252	1.76	2.38	1-5/8
1-1/2	1-1/2	4405x24	1.262	1.502	1.92	2.64	1-7/8

90° Elbow - Straight Thread O-Ring to Male For-Seal® (Ref. SAE No. 520220)

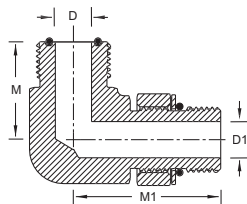
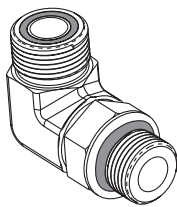

For replacement straight thread O-ring, see page 147.

Tube O.D.	Port Size	Catalog Number	D	D1	M	M1	Across Flats
1/4	1/4	4515x4	.172	.172	.85	1.29	9/16
1/4	5/16	4515x4x5	.172	.234	.85	1.29	9/16
1/4	3/8	4515x4x6	.172	.264	.92	1.45	3/4
1/4	1/2	4515x4x8	.172	.390	.97	1.60	3/4
3/8	1/4	4515x6x4	.264	.172	.98	1.37	3/4
3/8	5/16	4515x6x5	.264	.234	.98	1.37	3/4
3/8	3/8	4515x6	.264	.264	.98	1.45	3/4
3/8	1/2	4515x6x8	.264	.390	1.04	1.60	3/4
3/8	5/8	4515x6x10	.264	.484	1.15	1.97	3/4
3/8	3/4	4515x6x12	.264	.609	1.25	2.17	1-3/16
1/2	3/8	4515x8x6	.378	.264	1.10	1.44	3/4
1/2	1/2	4515x8	.378	.390	1.10	1.60	3/4
1/2	5/8	4515x8x10	.378	.484	1.21	1.97	1-1/16
1/2	3/4	4515x8x12	.378	.484	1.32	2.17	1-1/16
5/8	1/2	4515x10x8	.484	.390	1.31	1.80	1-1/16
5/8	5/8	4515x10	.484	.484	1.31	1.97	1-1/16
5/8	3/4	4515x10x12	.484	.609	1.41	2.17	1-3/16
3/4	1/2	4515x12x8	.609	.390	1.47	1.84	1-3/16
3/4	5/8	4515x12x10	.609	.484	1.47	2.01	1-5/16
3/4	3/4	4515x12	.609	.609	1.47	2.17	1-5/16
3/4	1	4515x12x16	.609	.811	1.62	2.35	1-5/16
1	3/4	4515x16x12	.811	.609	1.64	2.32	1-5/8
1	7/8	4515x16x14	.811	.609	1.64	2.32	1-5/8
1	1	4515x16	.811	.811	1.64	2.35	1-5/8
1	1-1/4	4515x16x20	.811	1.081	1.76	2.45	1-5/8
1-1/4	1	4515x20x16	1.024	.811	1.76	2.42	1-5/8
1-1/4	1-1/4	4515x20	1.024	1.081	1.76	2.45	1-7/8
1-1/4	1-1/2	4515x20x24	1.024	1.312	1.92	2.59	1-7/8
1-1/2	1-1/4	4515x24x20	1.312	1.081	1.92	2.59	1-7/8
1-1/2	1-1/2	4515x24	1.312	1.312	1.92	2.59	1-7/8

90° Elbow - For-Seal® Female Swivel to Male Straight Thread O-Ring
(Ref. SAE No. 520281)

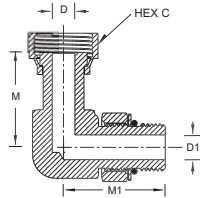
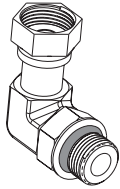

Tube O.D.	Port Size	Catalog Number	D	D1	M	M1	Hex C	Across Flats
1/4	1/4	4535x4	.165	.180	1.04	1.29	11/16	9/16
3/8	3/8	4535x6	.264	.300	1.15	1.45	13/16	3/4
1/2	1/2	4535x8	.358	.398	1.49	1.60	15/16	7/8
5/8	5/8	4535x10	.453	.498	1.62	1.97	1-1/8	1-1/16
3/4	3/4	4535x12	.547	.616	1.82	2.17	1-3/8	1-3/8
1	1	4535x16	.783	.852	2.10	2.35	1-5/8	1-5/8
1-1/4	1-1/4	4535x20	1.026	1.090	2.29	2.45	1-7/8	1-5/8
1-1/2	1-1/2	4535x24	1.262	1.326	2.41	2.59	2-1/4	1-7/8

Union Tee
(Ref. SAE No. 520401)

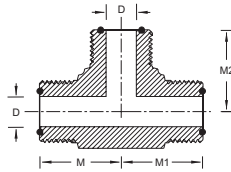
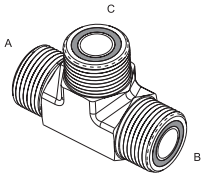

Tube O.D. A	Tube O.D. B	Tube O.D. C	Catalog Number	D	D1	M	M1	M2	Across Flats
1/4	1/4	1/4	4705x4	.172	.172	.85	.85	.85	9/16
3/8	3/8	3/8	4705x6	.264	.264	.98	.98	.98	3/4
3/8	3/8	1/2	4705x6x6x8	.264	.378	1.04	1.04	1.10	3/4
1/2	3/8	1/2	4705x8x6x8	.264	.378	.98	.98	1.10	3/4
1/2	1/2	1/2	4705x8	.378	.378	1.10	1.10	1.10	3/4
5/8	5/8	5/8	4705x10	.484	.484	1.31	1.31	1.31	1-1/16
3/4	3/4	1/4	4705x12x12x4	.609	.172	1.47	1.47	1.19	1-5/16
3/4	3/4	3/8	4705x12x12x6	.609	.264	1.47	1.47	1.25	1-5/16
3/4	3/4	3/4	4705x12	.609	.609	1.47	1.47	1.47	1-3/16
1	1	3/4	4705x16x16x12	.811	.609	1.64	1.64	1.62	1-5/8
1	1	1	4705x16	.811	.811	1.64	1.64	1.64	1-5/8
1-1/4	1-1/4	1	4705x20x20x16	1.024	.811	1.76	1.76	1.76	1-5/8
1-1/4	1-1/4	1-1/4	4705x20	1.024	1.024	1.76	1.76	1.76	1-5/8
1-1/2	1-1/2	1-1/2	4705x24	1.260	1.260	1.92	1.92	1.92	1-7/8

Straight Thread Branch Tee
(Ref. SAE No. 520429)

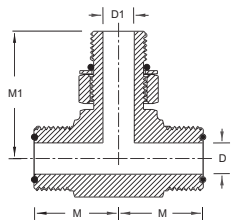
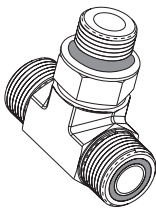

Tube O.D.	Port Size	Catalog Number	D	D1	M	M1	Across Flats
1/4	1/4	4715x4	.172	.172	.85	1.29	9/16
3/8	3/16	4715x6x6x3	.264	.130	.98	1.26	3/4
3/8	3/8	4715x6	.264	.264	.98	1.45	3/4
3/8	1/2	4715x6x6x8	.264	.391	1.04	1.60	7/8
1/2	3/8	4715x8x8x6	.378	.264	1.10	1.44	3/4
1/2	1/2	4715x8	.378	.390	1.10	1.60	3/4
5/8	5/8	4715x10	.484	.484	1.31	1.97	1-1/16
3/4	3/4	4715x12	.609	.609	1.47	2.17	1-3/16
3/4	1	4715x12x12x16	.609	.812	1.62	2.35	1-5/8
1	1	4715x16	.811	.845	1.64	2.35	1-5/8
1-1/4	1	4715x20x20x16	1.046	.845	1.76	2.45	1-15/16
1-1/4	1-1/4	4715x20	1.046	1.081	1.76	2.45	1-7/8
1-1/2	1-1/2	4715x24	1.260	1.313	1.92	2.59	1-7/8

For replacement straight thread O-ring, see page 147.

Straight Thread O-Ring Run Tee

(Ref. SAE No. 520428)

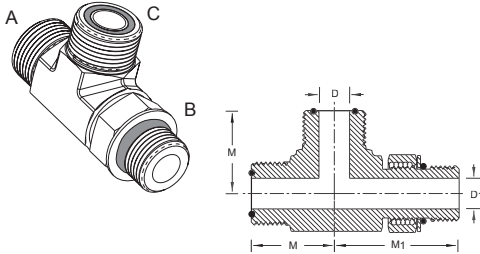

For replacement straight thread O-ring, see page 147.

Tube O.D. A	Port Size B	Tube O.D. C	Catalog Number	D	D1	M	M1	M2	Across Flats
1/4	1/4	1/4	4716x4	.172	.172	.85	1.29	.85	9/16
1/4	1/4	3/8	4716x4x6	.172	.264	1.39	1.45	1.39	3/4
3/8	3/8	3/8	4716x6	.264	.264	.98	1.45	.98	3/4
1/2	1/2	1/2	4716x8	.378	.391	1.10	1.60	1.10	7/8
5/8	5/8	5/8	4716x10	.484	.484	1.31	1.97	1.31	1-1/16
3/4	3/4	3/4	4716x12	.609	.609	1.47	2.17	1.47	1-3/16
3/4	3/4	1	4716x12x12x16	.609	.812	1.62	2.32	1.64	1-7/16
3/4	1	3/4	4716x12x16x12	.609	.812	1.62	2.35	1.62	1-7/16
1	1	3/4	4716x16x16x12	.812	.609	1.64	2.35	1.62	1-7/16
1	1	1	4716x16	.812	.845	1.64	2.35	1.64	1-7/16
1-1/4	1-1/4	1-1/4	4716x20	1.046	1.081	1.76	2.45	1.76	1-7/8
1-1/2	1-1/2	1-1/2	4716x24	1.313	1.313	1.92	2.59	1.92	1-7/8

Bulkhead Run Tee

(Ref. SAE No. 520958)

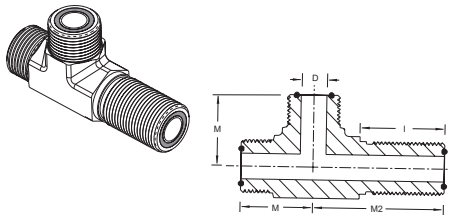

For Bulkhead Nut, see page 157.

Tube O.D.	Catalog Number	D	I	M	M2	Across Flats
1/4	4726x4	.172	1.24	.89	1.85	9/16
3/8	4726x6	.264	1.34	1.02	2.05	3/4
1/2	4726x8	.378	1.44	1.14	2.18	3/4
5/8	4726x10	.484	1.60	1.36	2.48	1-1/16
3/4	4726x12	.609	1.64	1.52	2.65	1-3/16
1	4726x16	.812	1.66	1.67	2.80	1-7/16
1-1/4	4726x20	1.024	1.66	1.79	2.97	1-5/8
1-1/2	4726x24	1.260	1.66	1.95	3.13	1-7/8

Male For-Seal® Cross

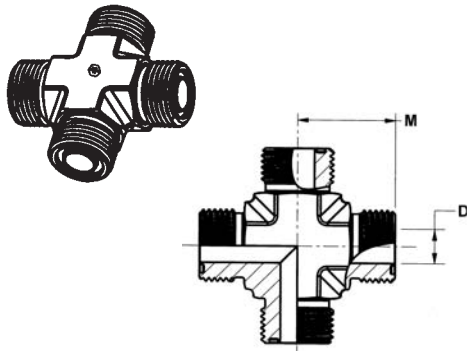

Tube O.D.	Catalog Number	D	M	Across Flats
1/4	4955x4	.172	.89	9/16
3/8	4955x6	.264	1.02	3/4
1/2	4955x8	.378	1.14	7/8
5/8	4955x10	.484	1.36	1-1/16
3/4	4955x12	.609	1.52	1-5/16
1	4955x16	.812	1.67	1-5/8
1-1/4	4955x20	1.026	1.79	1-5/8
1-1/2	4955x24	1.262	1.95	1-7/8

O-Ring, For-Seal®

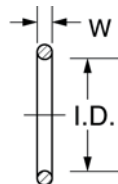

Material: Buna N, 90 Durometer
Temperature: -40°F to +250°F (-40°C to +121°C)
 Standard o-ring complies with SAE specification SAE J515 Type CH

Tube O.D.	Catalog Number	W	I.D.
1/4	4629x4	.070 ± .005	.301 ± .005
3/8	4629x6	.070 ± .005	.364 ± .005
1/2	4629x8	.070 ± .005	.489 ± .005
5/8	4629x10	.070 ± .005	.614 ± .005
3/4	4629x12	.070 ± .005	.739 ± .005
1	4629x16	.070 ± .006	.926 ± .006
1-1/4	4629x20	.070 ± .006	1.176 ± .006
1-1/2	4629x24	.070 ± .010	1.489 ± .010

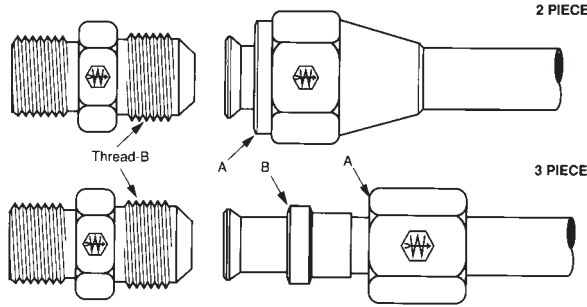

Tube O.D.	1/8	3/16	1/4	5/16	3/8	1/2	5/8	3/4	7/8	1	1-1/4	1-1/2	2
Thread Size-B	5/16-24	3/8-24	7/16-20	1/2-20	9/16-18	3/4-16	7/8-14	1-1/16-12	1-3/16-12	1-5/16-12	1-5/8-12	1-7/8-12	2-1/2-12

Forged Fittings and Adapters

5000 Series Pressure Rating Chart

Connection Type	End Size												
	1/8"	3/16"	1/4"	5/16"	3/8"	1/2"	5/8"	3/4"	7/8"	1"	1-1/4"	1-1/2"	2"
SAE Fittings	6000	5000	5000	5000	5000	4000	4000	4000	4000	4000	3000	3000	3000
W/Adjustable Straight Thread O-Ring	5000	5000	4500	4000	4000	4000	3000	3000	2500	2500	2000	1500	1125
With Male Pipe	6000		5000		5000	4000		4000		4000	3000	2500	2500
With Female Pipe	5000		5000		4000	3000		2500		2000	1500	1500	1000

Brazed Fittings (TF)/SAE

5000 Series Pressure Rating Chart

Connection Type	End Size												
	1/8"	3/16"	1/4"	5/16"	3/8"	1/2"	5/8"	3/4"	7/8"	1"	1-1/4"	1-1/2"	2"
SAE Fittings	5000	5000	5000	5000	5000	4500	3500	3500	3000	3000	2500	2000	1500
W/Adjustable Straight Thread O-Ring	5000	5000	4500	4000	4000	4000	3000	3000	2500	2500	2000	1500	1125
With Male or Female Pipe	5000	5000	5000	4000	4000	3000	3000	2500	2500	2000	1150	1000	1000

- Typical Application**
 Hydraulic, instrumentation and chemical processing systems.
- Pressure**
 Refer to the pressure charts above. The maximum working pressure of an adapter is the lower working pressure of the end size. Ex: C3069x8x6, 8 = 4000 psi and 6 = 5000 psi. Maximum working pressure is 4000 psi.
- Vibration**
 Good resistance. Vibration resistance decreases with increase in tube size. Use two piece design when greater vibration resistance is required.
- Temperature Range**
 -65°F to +400°F (-53°C to +204°C) at maximum operating pressures.
- Material**
 Carbon Steel - AISI/SAE 12L14
 Stainless Steel - Type 316
 Plating - Zinc, yellow dichromate.
- Used With**
 Copper, brass, steel, aluminum and other tubing that can be flared. See page 28-32 for material compatibility.
- Advantages**
 Zinc Plate. Choice of two or three-piece design. Broad selection of styles and sizes. Interchangeable with all sources.

- Conformance**
 Meets specifications and standards of ASA, ASME and SAE.
- How to Order**
 To order a three-piece assembly, prefix the catalog number with a "3". Example: To order a male connector C5205x4 with nut and sleeve assembled, order C35205x4. To order a two-piece assembly, order nut and body separately. Example: Order male connector C5205x4 and two-piece style nut C5115x4. Bodies, nuts and sleeves can be ordered separately by catalog number. Stainless steel bodies, nuts and sleeves are ordered separately by catalog number.

 To order Weathercote finish (black phosphate coating) use "W" prefix in place of "C". Example: W5205x4 (special order only).

 To order with pipe sealants (Seal-A-Thread), add a "Z" suffix to the catalog number. Example: C5205x4Z (special order only).
- NOTE**
 Refer to current price list for availability of cataloged items. Quotations and delivery of non-stock items supplied on request. Configurations and dimensions subject to change without notice. Additional information can be found in SAE J514.

- NOTE (Continued)**
 Weatherhead fittings with a "C" prefix are made from a forged construction. **Example:** C5405x4. Weatherhead fittings with a "TF" prefix are made from a brazed construction. Example: TF5405x4.
- Assembly Instructions**
 - Cut tubing to desired length. Make sure all burrs are removed and ends are cut square.
 - Slide nut on tube. Threaded end of nut "A" must face toward fitting body. (See above.)
 - Slide sleeve on tube (3-piece assembly only). Collar end "B" of sleeve must face toward fitting body. (See above.)
 - Flare end of tubing with 37° flaring tool.
 - Check flare diameter. For dimensional data on 37° flares, see page 26.
 - Examine flare for excessive thin-out.
 - On thin wall, welded or brazed tubing, use double flare to prevent pinch-off and cracked flares.
 - Lubricate threads and assemble to fitting body. Nut should be turned hand tight.
 - Tighten assembly until finger tight, then until a sharp torque rise is encountered. From that point, apply one-sixth turn with a wrench.

Label Set: FS-200 (adhesive)

Dimensional Data

Dimensional Data Two-Piece Assemblies

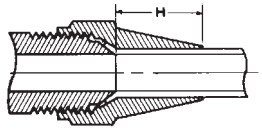

Dimensional Data Three-Piece Assemblies

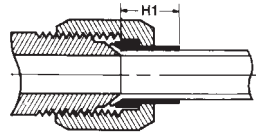

NOTE: H & H1 are dimensions of fittings assembled to hand tight condition.

Tube O.D.	H	H1
1/8	—	.31
3/16	—	.38
1/4	.59	.36
5/16	.66	.41
3/8	.69	.47
1/2	.81	.50
5/8	.94	.64
3/4	—	.61
7/8	—	.69
1	—	.75
1-1/4	—	.73
1-1/2	—	1.05
2	—	1.08

Straight Thread O-Ring Thread Sizes

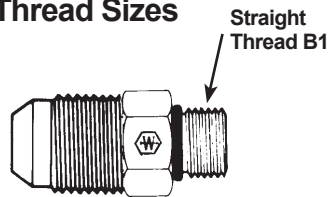

Port Size	Thread Size B1	Port Size	Thread Size B1
1/8	5/16-24	3/4	1-1/16-12
3/16	3/8-24	7/8	1-3/16-12
1/4	7/16-20	1	1-5/16-12
5/16	1/2-20	1-1/4	1-5/8-12
3/8	9/16-18	1-1/2	1-7/8-12
1/2	3/4-16	2	2-1/2-12
5/8	7/8-14		

Straight Thread O-Ring Fitting

Straight Thread O-Ring Fitting

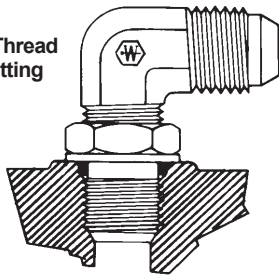

Adjustable Fittings

- Permit exact positioning of tees and elbows.
 - Provide a leakproof joint.
 - Eliminate distorted bosses from over tightening.
1. Lubricate O-ring by coating with a light oil or petrolatum and push back-up washer and O-ring to the extreme rear of the O-ring groove.
 2. Turn the lock nut down until it just contacts the back-up washer.
 3. Screw fitting by hand into straight thread boss until the back-up washer contacts the face of the boss.
 4. Position the fitting by backing out (counter-clockwise) up to one full turn. Hold fitting in desired position and tighten lock nut with a wrench.
 5. Assemble tube to fitting. Retighten lock nut.
- NOTE: O-ring, lock nuts and back-up washers are preassembled on all straight thread fittings.

Swivel Fitting (Used with Connector)

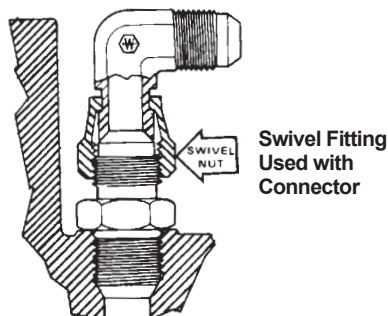

- Weatherhead swivel end fittings can be used with a straight connector when space limitations will not permit full rotation of standard straight thread elbows and tees.
1. Screw connector into the O-ring boss and tighten.
 2. Thread swivel nut onto connector.
 3. Hold fitting in desired position and tighten swivel nut with a wrench.

Sleeve 3 Piece
Stainless Steel No. **5177x**
(Ref. SAE No. 070115)

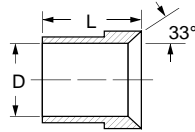

Tube O.D.	Catalog Number	D	L
1/8	C5165x2•	.130	.34
3/16	C5165x3•	.193	.34
1/4	C5165x4•	.255	.41
5/16	C5165x5•	.318	.44
3/8	C5165x6•	.380	.50
1/2	C5165x8•	.505	.56
5/8	C5165x10•	.631	.66
3/4	C5165x12•	.756	.68
7/8	C5165x14	.881	.76
1	C5165x16•	1.006	.78
1-1/4	C5165x20•	1.260	.91
1-1/2	C5165x24•	1.510	1.12
2	C5165x32•	2.014	1.19

Sleeve 3 Piece Metric
(Ref. SAE No. 070115)

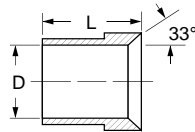

Adapts Standard SAE Flare-Twin® fittings for use with metric tubing.

Tube O.D. (Inch Size)	Tube O.D. (Metric Size)	Catalog Number	D	L
1/4	6MM	C5165x4x6MM	.241	.41
5/16	8MM	C5165x5x8MM	.320	.44
3/8	10MM	C5165x6x10MM	.399	.50
1/2	12MM	C5165x8x12MM	.478	.56
5/8	14MM	C5165x10x14MM	.556	.66
5/8	15MM	C5165x10x15MM	.596	.66
5/8	16MM	C5165x10x16MM	.636	.66
3/4	18MM	C5165x12x18MM	.717	.68
7/8	20MM	C5165x14x20MM	.793	.76
1	25MM	C5165x16x25MM	.990	.78
1-1/4	30MM	C5165x20x30MM	1.191	.91
1-1/4	32MM	C5165x20x32MM	1.270	.91
1-1/2	38MM	C5165x24x38MM	1.510	1.12

Nut 3 Piece
Stainless Steel No. **5117x**
(Ref. SAE No. 070110)

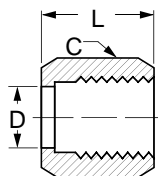
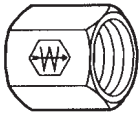

SAE style 'B'

Tube O.D.	Catalog Number	Hex C	D	L
1/8	C5105x2•	3/8	.181	.55
3/16	C5105x3•	7/16	.243	.61
1/4	C5105x4•	9/16	.306	.62
5/16	C5105x5•	5/8	.375	.68
3/8	C5105x6•	11/16	.441	.73
1/2	C5105x8•	7/8	.571	.85
5/8	C5105x10•	1	.698	.98
3/4	C5105x12•	1-1/4	.835	1.03
7/8	C5105x14	1-3/8	.961	1.09
1	C5105x16•	1-1/2	1.089	1.13
1-1/4	C5105x20•	2	1.347	1.23
1-1/2	C5105x24•	2-1/4	1.617	1.42
2	C5105x32•	2-7/8	2.167	1.75

2 Piece Nut (Short)

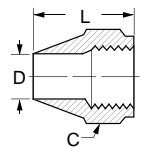
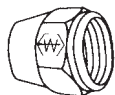

Tube O.D.	Catalog Number	Hex C	D	L
1/4	C5125x4	9/16	.255	.59
5/16	C5125x5	5/8	.318	.59
3/8	C5125x6	11/16	.380	.66
1/2	C5125x8	7/8	.505	.81
5/8	C5125x10	1	.631	.94
3/4	C5125x12	1-1/4	.756	1.14

2 Piece Nut
(Ref. SAE No. 070111)

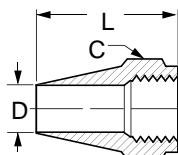
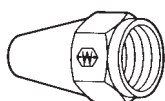

SAE style 'A'

Tube O.D.	Catalog Number	Hex C	D	L
1/4	C5115x4	9/16	.255	1.00
5/16	C5115x5	5/8	.318	1.06
3/8	C5115x6	11/16	.380	1.09
1/2	C5115x8	7/8	.505	1.28
5/8	C5115x10	1	.631	1.48
3/4	C5115x12	1-1/4	.756	1.66
7/8	C5115x14	1-3/8	.881	1.81
1	C5115x16	1-1/2	1.006	1.94
1-1/4	C5115x20	2	1.260	2.19
1-1/2	C5115x24	2-1/4	1.510	2.31

• Available in stainless steel.

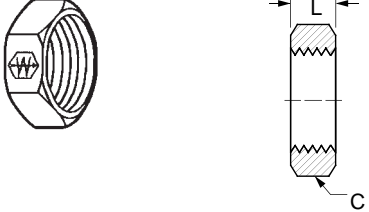
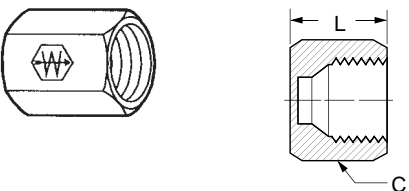
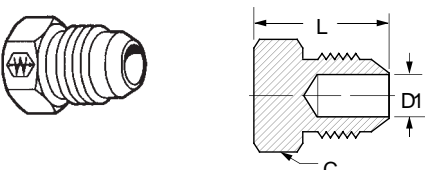
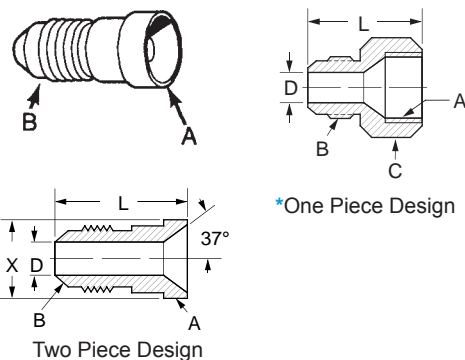
<p>Bulkhead Nut Stainless Steel No. 7936x (Ref. SAE No. 070118)</p> 	<table border="1"> <thead> <tr> <th>Tube O.D.</th> <th>Catalog Number</th> <th>Hex C</th> <th>L</th> </tr> </thead> <tbody> <tr><td>1/8</td><td>C5924x2</td><td>9/16</td><td>.22</td></tr> <tr><td>3/16</td><td>C5924x3</td><td>5/8</td><td>.22</td></tr> <tr><td>1/4</td><td>C5924x4*</td><td>11/16</td><td>.25</td></tr> <tr><td>5/16</td><td>C5924x5</td><td>3/4</td><td>.28</td></tr> <tr><td>3/8</td><td>C5924x6*</td><td>13/16</td><td>.27</td></tr> <tr><td>1/2</td><td>C5924x8*</td><td>1</td><td>.31</td></tr> <tr><td>5/8</td><td>C5924x10</td><td>1-1/8</td><td>.36</td></tr> <tr><td>3/4</td><td>C5924x12*</td><td>1-3/8</td><td>.41</td></tr> <tr><td>7/8</td><td>C5924x14</td><td>1-1/2</td><td>.41</td></tr> <tr><td>1</td><td>C5924x16*</td><td>1-5/8</td><td>.41</td></tr> <tr><td>1-1/4</td><td>C5924x20</td><td>1-7/8</td><td>.41</td></tr> <tr><td>1-1/2</td><td>C5924x24</td><td>2-1/8</td><td>.41</td></tr> <tr><td>2</td><td>C5924x32</td><td>2-3/4</td><td>.41</td></tr> </tbody> </table>	Tube O.D.	Catalog Number	Hex C	L	1/8	C5924x2	9/16	.22	3/16	C5924x3	5/8	.22	1/4	C5924x4*	11/16	.25	5/16	C5924x5	3/4	.28	3/8	C5924x6*	13/16	.27	1/2	C5924x8*	1	.31	5/8	C5924x10	1-1/8	.36	3/4	C5924x12*	1-3/8	.41	7/8	C5924x14	1-1/2	.41	1	C5924x16*	1-5/8	.41	1-1/4	C5924x20	1-7/8	.41	1-1/2	C5924x24	2-1/8	.41	2	C5924x32	2-3/4	.41																																																																																																									
Tube O.D.	Catalog Number	Hex C	L																																																																																																																																																															
1/8	C5924x2	9/16	.22																																																																																																																																																															
3/16	C5924x3	5/8	.22																																																																																																																																																															
1/4	C5924x4*	11/16	.25																																																																																																																																																															
5/16	C5924x5	3/4	.28																																																																																																																																																															
3/8	C5924x6*	13/16	.27																																																																																																																																																															
1/2	C5924x8*	1	.31																																																																																																																																																															
5/8	C5924x10	1-1/8	.36																																																																																																																																																															
3/4	C5924x12*	1-3/8	.41																																																																																																																																																															
7/8	C5924x14	1-1/2	.41																																																																																																																																																															
1	C5924x16*	1-5/8	.41																																																																																																																																																															
1-1/4	C5924x20	1-7/8	.41																																																																																																																																																															
1-1/2	C5924x24	2-1/8	.41																																																																																																																																																															
2	C5924x32	2-3/4	.41																																																																																																																																																															
<p>Cap Stainless Steel No. 5141x (Ref. SAE No. 070112)</p> 	<table border="1"> <thead> <tr> <th>Tube O.D.</th> <th>Catalog Number</th> <th>Hex C</th> <th>L</th> </tr> </thead> <tbody> <tr><td>1/8</td><td>C5129x2</td><td>3/8</td><td>.50</td></tr> <tr><td>3/16</td><td>C5129x3</td><td>7/16</td><td>.56</td></tr> <tr><td>1/4</td><td>C5129x4*</td><td>9/16</td><td>.59</td></tr> <tr><td>5/16</td><td>C5129x5*</td><td>5/8</td><td>.61</td></tr> <tr><td>3/8</td><td>C5129x6*</td><td>11/16</td><td>.62</td></tr> <tr><td>1/2</td><td>C5129x8*</td><td>7/8</td><td>.75</td></tr> <tr><td>5/8</td><td>C5129x10*</td><td>1</td><td>.84</td></tr> <tr><td>3/4</td><td>C5129x12*</td><td>1-1/4</td><td>.91</td></tr> <tr><td>1</td><td>C5129x16*</td><td>1-1/2</td><td>1.02</td></tr> <tr><td>1-1/4</td><td>C5129x20*</td><td>2</td><td>1.06</td></tr> <tr><td>1-1/2</td><td>C5129x24</td><td>2-1/4</td><td>1.19</td></tr> <tr><td>2</td><td>C5129x32</td><td>2-7/8</td><td>1.44</td></tr> </tbody> </table>	Tube O.D.	Catalog Number	Hex C	L	1/8	C5129x2	3/8	.50	3/16	C5129x3	7/16	.56	1/4	C5129x4*	9/16	.59	5/16	C5129x5*	5/8	.61	3/8	C5129x6*	11/16	.62	1/2	C5129x8*	7/8	.75	5/8	C5129x10*	1	.84	3/4	C5129x12*	1-1/4	.91	1	C5129x16*	1-1/2	1.02	1-1/4	C5129x20*	2	1.06	1-1/2	C5129x24	2-1/4	1.19	2	C5129x32	2-7/8	1.44																																																																																																													
Tube O.D.	Catalog Number	Hex C	L																																																																																																																																																															
1/8	C5129x2	3/8	.50																																																																																																																																																															
3/16	C5129x3	7/16	.56																																																																																																																																																															
1/4	C5129x4*	9/16	.59																																																																																																																																																															
5/16	C5129x5*	5/8	.61																																																																																																																																																															
3/8	C5129x6*	11/16	.62																																																																																																																																																															
1/2	C5129x8*	7/8	.75																																																																																																																																																															
5/8	C5129x10*	1	.84																																																																																																																																																															
3/4	C5129x12*	1-1/4	.91																																																																																																																																																															
1	C5129x16*	1-1/2	1.02																																																																																																																																																															
1-1/4	C5129x20*	2	1.06																																																																																																																																																															
1-1/2	C5129x24	2-1/4	1.19																																																																																																																																																															
2	C5129x32	2-7/8	1.44																																																																																																																																																															
<p>Plug Stainless Steel No. 5241x (Ref. SAE No. 070109)</p> 	<table border="1"> <thead> <tr> <th>Tube O.D.</th> <th>Catalog Number</th> <th>Hex C</th> <th>L</th> <th>D1 Opt.</th> </tr> </thead> <tbody> <tr><td>1/4</td><td>C5229x4*</td><td>1/2</td><td>.80</td><td>.172</td></tr> <tr><td>5/16</td><td>C5229x5*</td><td>9/16</td><td>.80</td><td>.234</td></tr> <tr><td>3/8</td><td>C5229x6*</td><td>5/8</td><td>.84</td><td>.297</td></tr> <tr><td>1/2</td><td>C5229x8*</td><td>13/16</td><td>.94</td><td>.391</td></tr> <tr><td>5/8</td><td>C5229x10*</td><td>15/16</td><td>1.10</td><td>.484</td></tr> <tr><td>3/4</td><td>C5229x12*</td><td>1-1/8</td><td>1.28</td><td>.609</td></tr> <tr><td>7/8</td><td>C5229x14</td><td>1-1/4</td><td>1.31</td><td>.719</td></tr> <tr><td>1</td><td>C5229x16*</td><td>1-3/8</td><td>1.33</td><td>.844</td></tr> <tr><td>1-1/4</td><td>C5229x20</td><td>1-11/16</td><td>1.45</td><td>1.078</td></tr> <tr><td>1-1/2</td><td>C5229x24</td><td>2</td><td>1.65</td><td>1.312</td></tr> <tr><td>2</td><td>C5229x32</td><td>2-5/8</td><td>2.05</td><td>1.781</td></tr> </tbody> </table>	Tube O.D.	Catalog Number	Hex C	L	D1 Opt.	1/4	C5229x4*	1/2	.80	.172	5/16	C5229x5*	9/16	.80	.234	3/8	C5229x6*	5/8	.84	.297	1/2	C5229x8*	13/16	.94	.391	5/8	C5229x10*	15/16	1.10	.484	3/4	C5229x12*	1-1/8	1.28	.609	7/8	C5229x14	1-1/4	1.31	.719	1	C5229x16*	1-3/8	1.33	.844	1-1/4	C5229x20	1-11/16	1.45	1.078	1-1/2	C5229x24	2	1.65	1.312	2	C5229x32	2-5/8	2.05	1.781																																																																																																					
Tube O.D.	Catalog Number	Hex C	L	D1 Opt.																																																																																																																																																														
1/4	C5229x4*	1/2	.80	.172																																																																																																																																																														
5/16	C5229x5*	9/16	.80	.234																																																																																																																																																														
3/8	C5229x6*	5/8	.84	.297																																																																																																																																																														
1/2	C5229x8*	13/16	.94	.391																																																																																																																																																														
5/8	C5229x10*	15/16	1.10	.484																																																																																																																																																														
3/4	C5229x12*	1-1/8	1.28	.609																																																																																																																																																														
7/8	C5229x14	1-1/4	1.31	.719																																																																																																																																																														
1	C5229x16*	1-3/8	1.33	.844																																																																																																																																																														
1-1/4	C5229x20	1-11/16	1.45	1.078																																																																																																																																																														
1-1/2	C5229x24	2	1.65	1.312																																																																																																																																																														
2	C5229x32	2-5/8	2.05	1.781																																																																																																																																																														
<p>Reducer Stainless Steel No. 5027x (Ref. SAE No. 070123) Example assembly No. C35015x</p>  <p>*One Piece Design</p> <p>Two Piece Design</p> <p>NOTE: Order 3-piece nut C5105x to use reducer. No sleeve necessary.</p>	<table border="1"> <thead> <tr> <th>Female Reduction A</th> <th>Male Reduction B</th> <th>Catalog Number</th> <th>D</th> <th>L</th> <th>Dia. X</th> <th>Hex C</th> </tr> </thead> <tbody> <tr><td>3/8</td><td>1/4</td><td>C5015x6x4*</td><td>.172</td><td>.97</td><td>.502</td><td>—</td></tr> <tr><td>1/2</td><td>1/4</td><td>C5015x8x4*</td><td>.172</td><td>1.00</td><td>.682</td><td>—</td></tr> <tr><td>1/2</td><td>3/8</td><td>C5015x8x6*</td><td>.297</td><td>1.00</td><td>.682</td><td>—</td></tr> <tr><td>5/8*</td><td>1/4</td><td>C5015x10x4*</td><td>.172</td><td>1.47</td><td>—</td><td>1</td></tr> <tr><td>5/8*</td><td>3/8</td><td>C5015x10x6*</td><td>.297</td><td>1.41</td><td>—</td><td>1</td></tr> <tr><td>5/8*</td><td>1/2</td><td>C5015x10x8*</td><td>.391</td><td>1.41</td><td>—</td><td>1</td></tr> <tr><td>3/4</td><td>1/4</td><td>C5015x12x4*</td><td>.172</td><td>1.09</td><td>.972</td><td>—</td></tr> <tr><td>3/4</td><td>3/8</td><td>C5015x12x6*</td><td>.297</td><td>1.09</td><td>.972</td><td>—</td></tr> <tr><td>3/4</td><td>1/2</td><td>C5015x12x8*</td><td>.391</td><td>1.19</td><td>.972</td><td>—</td></tr> <tr><td>3/4*</td><td>5/8</td><td>C5015x12x10</td><td>.484</td><td>1.58</td><td>—</td><td>1-1/4</td></tr> <tr><td>7/8*</td><td>3/8</td><td>C5015x14x6</td><td>.297</td><td>1.59</td><td>—</td><td>1-3/8</td></tr> <tr><td>7/8*</td><td>1/2</td><td>C5015x14x8</td><td>.391</td><td>1.69</td><td>—</td><td>1-3/8</td></tr> <tr><td>7/8*</td><td>5/8</td><td>C5015x14x10</td><td>.484</td><td>1.73</td><td>—</td><td>1-3/8</td></tr> <tr><td>7/8*</td><td>3/4</td><td>C5015x14x12</td><td>.609</td><td>1.80</td><td>—</td><td>1-3/8</td></tr> <tr><td>1*</td><td>1/2</td><td>C5015x16x8</td><td>.391</td><td>1.72</td><td>—</td><td>1-1/2</td></tr> <tr><td>1*</td><td>5/8</td><td>C5015x16x10</td><td>.484</td><td>1.79</td><td>—</td><td>1-1/2</td></tr> <tr><td>1*</td><td>3/4</td><td>C5015x16x12*</td><td>.609</td><td>1.47</td><td>1.222</td><td>—</td></tr> <tr><td>1*</td><td>7/8</td><td>C5015x16x14</td><td>.719</td><td>1.87</td><td>—</td><td>1-1/2</td></tr> <tr><td>1-1/4</td><td>3/4</td><td>C5015x20x12</td><td>.609</td><td>1.50</td><td>1.534</td><td>—</td></tr> <tr><td>1-1/4*</td><td>1</td><td>C5015x20x16</td><td>.844</td><td>2.00</td><td>—</td><td>2</td></tr> <tr><td>1-1/2*</td><td>1-1/4</td><td>C5015x24x20</td><td>1.078</td><td>2.15</td><td>—</td><td>2-1/4</td></tr> <tr><td>2*</td><td>1-1/2</td><td>C5015x32x24</td><td>1.312</td><td>2.61</td><td>—</td><td>2-7/8</td></tr> </tbody> </table>	Female Reduction A	Male Reduction B	Catalog Number	D	L	Dia. X	Hex C	3/8	1/4	C5015x6x4*	.172	.97	.502	—	1/2	1/4	C5015x8x4*	.172	1.00	.682	—	1/2	3/8	C5015x8x6*	.297	1.00	.682	—	5/8*	1/4	C5015x10x4*	.172	1.47	—	1	5/8*	3/8	C5015x10x6*	.297	1.41	—	1	5/8*	1/2	C5015x10x8*	.391	1.41	—	1	3/4	1/4	C5015x12x4*	.172	1.09	.972	—	3/4	3/8	C5015x12x6*	.297	1.09	.972	—	3/4	1/2	C5015x12x8*	.391	1.19	.972	—	3/4*	5/8	C5015x12x10	.484	1.58	—	1-1/4	7/8*	3/8	C5015x14x6	.297	1.59	—	1-3/8	7/8*	1/2	C5015x14x8	.391	1.69	—	1-3/8	7/8*	5/8	C5015x14x10	.484	1.73	—	1-3/8	7/8*	3/4	C5015x14x12	.609	1.80	—	1-3/8	1*	1/2	C5015x16x8	.391	1.72	—	1-1/2	1*	5/8	C5015x16x10	.484	1.79	—	1-1/2	1*	3/4	C5015x16x12*	.609	1.47	1.222	—	1*	7/8	C5015x16x14	.719	1.87	—	1-1/2	1-1/4	3/4	C5015x20x12	.609	1.50	1.534	—	1-1/4*	1	C5015x20x16	.844	2.00	—	2	1-1/2*	1-1/4	C5015x24x20	1.078	2.15	—	2-1/4	2*	1-1/2	C5015x32x24	1.312	2.61	—	2-7/8
Female Reduction A	Male Reduction B	Catalog Number	D	L	Dia. X	Hex C																																																																																																																																																												
3/8	1/4	C5015x6x4*	.172	.97	.502	—																																																																																																																																																												
1/2	1/4	C5015x8x4*	.172	1.00	.682	—																																																																																																																																																												
1/2	3/8	C5015x8x6*	.297	1.00	.682	—																																																																																																																																																												
5/8*	1/4	C5015x10x4*	.172	1.47	—	1																																																																																																																																																												
5/8*	3/8	C5015x10x6*	.297	1.41	—	1																																																																																																																																																												
5/8*	1/2	C5015x10x8*	.391	1.41	—	1																																																																																																																																																												
3/4	1/4	C5015x12x4*	.172	1.09	.972	—																																																																																																																																																												
3/4	3/8	C5015x12x6*	.297	1.09	.972	—																																																																																																																																																												
3/4	1/2	C5015x12x8*	.391	1.19	.972	—																																																																																																																																																												
3/4*	5/8	C5015x12x10	.484	1.58	—	1-1/4																																																																																																																																																												
7/8*	3/8	C5015x14x6	.297	1.59	—	1-3/8																																																																																																																																																												
7/8*	1/2	C5015x14x8	.391	1.69	—	1-3/8																																																																																																																																																												
7/8*	5/8	C5015x14x10	.484	1.73	—	1-3/8																																																																																																																																																												
7/8*	3/4	C5015x14x12	.609	1.80	—	1-3/8																																																																																																																																																												
1*	1/2	C5015x16x8	.391	1.72	—	1-1/2																																																																																																																																																												
1*	5/8	C5015x16x10	.484	1.79	—	1-1/2																																																																																																																																																												
1*	3/4	C5015x16x12*	.609	1.47	1.222	—																																																																																																																																																												
1*	7/8	C5015x16x14	.719	1.87	—	1-1/2																																																																																																																																																												
1-1/4	3/4	C5015x20x12	.609	1.50	1.534	—																																																																																																																																																												
1-1/4*	1	C5015x20x16	.844	2.00	—	2																																																																																																																																																												
1-1/2*	1-1/4	C5015x24x20	1.078	2.15	—	2-1/4																																																																																																																																																												
2*	1-1/2	C5015x32x24	1.312	2.61	—	2-7/8																																																																																																																																																												

* Available in stainless steel.

Small Hex Union

Stainless Steel No. **5317x**

(Ref. SAE No. 070101)

Example assembly No. **C35305x2**

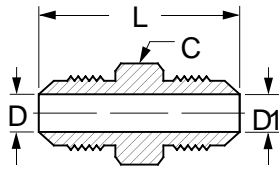
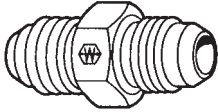

Tube O.D.	Tube O.D.	Catalog Number	Hex C	D	D1	L
1/8	1/8	C5305x2	7/16	.062	.062	1.17
3/16	3/16	C5305x3	7/16	.125	.125	1.23
1/4	1/4	C5305x4*	1/2	.172	.172	1.37
5/16	1/4	C5305x5x4	9/16	.234	.172	1.37
5/16	5/16	C5305x5*	9/16	.234	.234	1.37
3/8	1/4	C5305x6x4	5/8	.297	.172	1.40
3/8	5/16	C5305x6x5	5/8	.297	.234	1.40
3/8	3/8	C5305x6*	5/8	.297	.297	1.41
1/2	3/8	C5305x8x6	13/16	.391	.297	1.52
1/2	1/2	C5305x8*	13/16	.391	.391	1.62
5/8	1/2	C5305x10x8	15/16	.484	.391	1.78
5/8	5/8	C5305x10*	15/16	.484	.484	1.88
3/4	1/2	C5305x12x8	1-1/8	.609	.391	1.95
3/4	5/8	C5305x12x10	1-1/8	.609	.484	2.05
3/4	3/4	C5305x12*	1-1/8	.609	.609	2.16
7/8	7/8	C5305x14	1-1/4	.719	.719	2.21
1	3/4	C5305x16x12	1-3/8	.844	.609	2.20
1	1	C5305x16*	1-3/8	.844	.844	2.25
1-1/4	1-1/4	C5305x20	1-11/16	1.078	1.078	2.43
1-1/2	1-1/2	C5305x24	2	1.312	1.312	2.75
2	2	C5305x32	2-5/8	1.781	1.781	3.40

Large Hex Union

Stainless Steel No. **5318x**

(Ref. SAE No. 070119)

Example assembly No. **C35306x4**

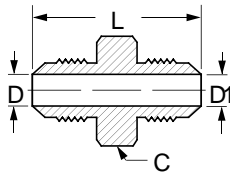
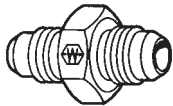

Tube O.D.	Catalog Number	Hex C	D	D1	L
1/4	C5306x4*	11/16	.172	.172	1.37
5/16	C5306x5*	3/4	.234	.234	1.37
3/8	C5306x6*	13/16	.297	.297	1.41
1/2	C5306x8*	1	.391	.391	1.62
5/8	C5306x10*	1-1/8	.484	.484	1.88
3/4	C5306x12*	1-3/8	.609	.609	2.16
1	C5306x16*	1-5/8	.844	.844	2.25
1-1/4	C5306x20	1-7/8	1.078	1.078	2.43
1-1/2	C5306x24	2-1/8	1.312	1.312	2.75

5318x6x4*, 5318x8x6*

Bulkhead Union

Stainless Steel No. **5337x**

(Ref. SAE No. 070601)

Example assembly No. **C35325x4**

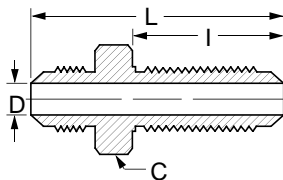
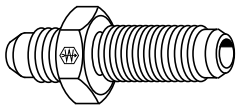

Tube O.D.	Catalog Number	Hex C	D	I	L
3/16	C5325x3	5/8	.125	1.14	1.90
1/4	C5325x4*	11/16	.172	1.23	2.07
5/16	C5325x5	3/4	.234	1.23	2.07
3/8	C5325x6*	13/16	.297	1.31	2.18
1/2	C5325x8*	1	.391	1.47	2.44
5/8	C5325x10*	1-1/8	.484	1.61	2.74
3/4	C5325x12*	1-3/8	.609	1.78	3.09
1	C5325x16	1-5/8	.844	1.78	3.14
1-1/4	C5325x20	1-7/8	1.078	1.83	3.31

For Bulkhead nut see page 167. Included with assembly.

* Available in stainless steel.

Male Connector

Stainless Steel No. **5217x**
(Ref. SAE No. 070102)
Example assembly No. **C35205x4**

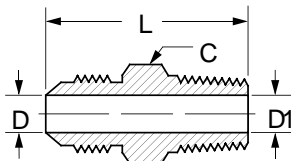
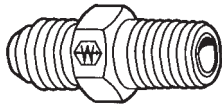

*Optional counterbore for D1.

Tube O.D.	Male Pipe Thread	Catalog Number	Hex C	D	D1 Opt.	L
1/8	1/8	C5205x2•	7/16	.062	.188*	1.11
3/16	1/8	C5205x3	7/16	.125	.188*	1.14
1/4	1/8	C5205x4•	1/2	.172	.188*	1.22
1/4	1/4	C5205x4x4•	9/16	.172	.281*	1.42
1/4	3/8	C5205x4x6	3/4	.172	.406*	1.42
1/4	1/2	C5205x4x8	7/8	.172	.531*	1.68
5/16	1/8	C5205x5	9/16	.234	.188	1.22
5/16	1/4	C5205x5x4•	5/8	.234	.281*	1.42
5/16	3/8	C5205x5x6	13/16	.234	.406*	1.42
3/8	1/8	C5205x6x2•	5/8	.297	.188	1.24
3/8	1/4	C5205x6•	5/8	.297	.281	1.43
3/8	3/8	C5205x6x6•	3/4	.297	.297*	1.43
3/8	1/2	C5205x6x8•	7/8	.297	.531*	1.69
1/2	1/4	C5205x8x4•	13/16	.391	.281	1.53
1/2	3/8	C5205x8•	13/16	.391	.406*	1.53
1/2	1/2	C5205x8x8•	15/16	.391	.531*	1.79
1/2	3/4	C5205x8x12•	1-1/8	.391	.719*	1.85
5/8	3/8	C5205x10x6	15/16	.484	.406	1.70
5/8	1/2	C5205x10•	15/16	.484	.531*	1.89
5/8	3/4	C5205x10x12	1-1/8	.484	.484*	1.95
3/4	1/2	C5205x12x8•	1-1/8	.609	.531	2.06
3/4	3/4	C5205x12•	1-1/8	.609	.719*	2.06
3/4	1	C5205x12x16	1-3/8	.609	.938*	2.25
7/8	3/4	C5205x14	1-1/4	.718	.718*	2.09
1	3/4	C5205x16x12	1-3/8	.844	.719	2.25
1	1	C5205x16•	1-3/8	.844	.938*	2.30
1	1-1/4	C5205x16x20	1-11/16	.844	1.250*	2.40
1-1/4	1	C5205x20x16	1-11/16	1.078	.938	2.42
1-1/4	1-1/4	C5205x20	1-11/16	1.078	1.250*	2.45
1-1/2	1-1/4	C5205x24x20	2	1.312	1.250*	2.65
1-1/2	1-1/2	C5205x24	2	1.312	1.500*	2.68
2	2	C5205x32	2-5/8	1.781	1.938*	3.11

Female Connector

Stainless Steel No. **5267x**
(Ref. SAE No. 070103)
Example assembly No. **C35255x4**

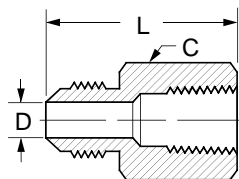
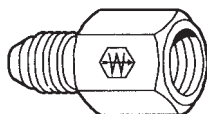

Tube O.D.	Fem. Pipe Thread	Catalog Number	Hex C	D	L
1/8	1/8	C5255x2	9/16	.062	1.12
3/16	1/8	C5255x3	9/16	.125	1.13
1/4	1/8	C5255x4•	9/16	.172	1.19
1/4	1/4	C5255x4x4•	3/4	.172	1.39
5/16	1/8	C5255x5	9/16	.234	1.17
5/16	1/4	C5255x5x4•	3/4	.234	1.39
3/8	1/4	C5255x6•	3/4	.297	1.40
3/8	3/8	C5255x6x6•	7/8	.297	1.46
1/2	3/8	C5255x8•	7/8	.391	1.56
1/2	1/2	C5255x8x8•	1-1/8	.391	1.79
5/8	3/8	C5255x10x6	7/8	.484	1.89
5/8	1/2	C5255x10•	1-1/8	.484	1.89
3/4	1/2	C5255x12x8•	1-1/8	.609	2.05
3/4	3/4	C5255x12•	1-3/8	.609	2.06
7/8	3/4	C5255x14	1-3/8	.875	2.06
1	1	C5255x16•	1-5/8	.844	2.35
1-1/4	1-1/4	C5255x20	2	1.078	2.49
1-1/2	1-1/2	C5255x24	2-3/8	1.312	2.62
2	2	C5255x32	2-7/8	1.781	2.97

Female Bulkhead Connector

Example assembly No. **C35275x4**

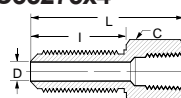
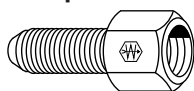

For Bulkhead nut see page 167. Included with assembly.

Tube O.D.	Fem. Pipe Thread	Catalog Number	Hex C	D	I	L
1/4	1/8	C5275x4	11/16	.172	1.23	1.84
3/8	1/4	C5275x6	13/16	.297	1.31	2.06
1/2	3/8	C5275x8	1	.391	1.47	2.35
5/8	1/2	C5275x10	1-1/8	.484	1.61	2.66
3/4	3/4	C5275x12	1-3/8	.609	1.78	2.91
1	1	C5275x16	1-5/8	.844	1.78	3.09

• Available in stainless steel.

Male JIC 37° SAE to Female For-Seal®

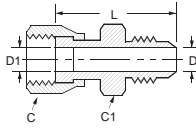
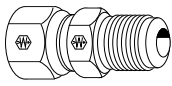

Female Tube O.D.	Male 37° Tube Size	Catalog Number	Hex C1	Hex C	D	D1	L
1/4	1/4	4213x4	11/16	5/8	.172	.165	1.50
3/8	3/8	4213x6	13/16	3/4	.297	.264	1.62
1/2	1/2	4213x8	15/16	7/8	.397	.358	1.90
5/8	5/8	4213x10	1-1/8	1-1/16	.484	.453	2.25
3/4	3/4	4213x12	1-3/16	1-1/4	.609	.547	2.48
1	1	4213x16	1-5/8	1-1/2	.811	.783	2.84

Straight Thread O-Ring Connector

Stainless Steel No. 5327x

(Ref. SAE No. 070120)

Example assembly No. C35315x4

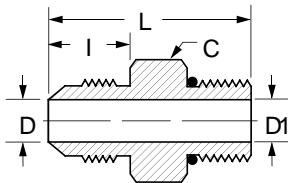
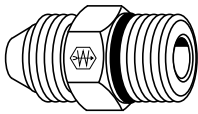

Tube O.D.	Port Size	Catalog Number	Hex C	D	D1 Opt.	I	L
1/8	1/8	C5315x2•	7/16	.062	.062*	.45	1.06
3/16	3/16	C5315x3	1/2	.125	.125*	.48	1.10
1/4	1/4	C5315x4•	9/16	.172	.172*	.55	1.23
1/4	5/16	C5315x4x5•	5/8	.172	.234*	.55	1.23
1/4	3/8	C5315x4x6	11/16	.172	.297*	.55	1.29
1/4	1/2	C5315x4x8	7/8	.172	.391*	.55	1.37
5/16	1/4	C5315x5x4	5/8	.234	.172	.55	1.23
5/16	5/16	C5315x5	5/8	.234	.234*	.55	1.23
5/16	3/8	C5315x5x6	11/16	.234	.297*	.55	1.29
3/8	1/4	C5315x6x4	11/16	.297	.172	.56	1.27
3/8	5/16	C5315x6x5	11/16	.297	.234	.56	1.27
3/8	3/8	C5315x6•	11/16	.297	.297*	.56	1.30
3/8	1/2	C5315x6x8•	7/8	.297	.391*	.56	1.38
3/8	5/8	C5315x6x10	1	.297	.484*	.56	1.50
1/2	3/8	C5315x8x6	13/16	.391	.297	.66	1.44
1/2	1/2	C5315x8•	7/8	.391	.391*	.66	1.48
1/2	5/8	C5315x8x10•	1	.391	.484*	.66	1.60
1/2	3/4	C5315x8x12•	1-1/4	.391	.609*	.66	1.76
5/8	1/2	C5315x10x8	1	.484	.391	.76	1.64
5/8	5/8	C5315x10•	1	.484	.484*	.76	1.70
5/8	3/4	C5315x10x12	1-1/4	.484	.609*	.76	1.86
5/8	1	C5315x10x16	1-1/2	.484	.844*	.76	1.89
3/4	1/2	C5315x12x8	1-1/4	.609	.391	.86	1.94
3/4	5/8	C5315x12x10	1-1/8	.609	.484	.86	1.88
3/4	3/4	C5315x12•	1-1/4	.609	.609*	.86	1.97
3/4	7/8	C5315x12x14	1-3/8	.609	.718*	.86	1.96
3/4	1	C5315x12x16	1-1/2	.609	.844*	.86	1.99
3/4	1-1/4	C5315x12x20	1-7/8	.609	1.078*	.86	2.08
7/8	7/8	C5315x14	1-3/8	.719	.719*	.89	1.99
1	5/8	C5315x16x10	1-1/2	.844	.484	.91	2.07
1	3/4	C5315x16x12	1-1/2	.844	.609	.91	2.04
1	1	C5315x16•	1-1/2	.844	.844*	.91	2.04
1	1-1/4	C5315x16x20	1-7/8	.844	1.078*	.91	2.12
1-1/4	1	C5315x20x16	1-7/8	1.078	.844	.96	2.33
1-1/4	1-1/4	C5315x20	1-7/8	1.078	1.078*	.96	2.17
1-1/4	1-1/2	C5315x20x24	2-1/8	1.078	1.312*	.96	2.24
1-1/2	1-1/4	C5315x24x20	2-1/8	1.312	1.078*	1.08	2.53
1-1/2	1-1/2	C5315x24	2-1/8	1.312	1.312*	1.08	2.37
1-1/2	2	C5315x24x32	2-3/4	1.312	1.781*	1.08	2.53
2	1-1/2	C5315x32x24	2-3/4	1.781	1.312*	1.33	2.81
2	2	C5315x32	2-3/4	1.781	1.781	1.33	2.78

*Optional counterbore for D1.
Replacement O-rings page 183.

Straight Thread O-Ring Extended Connector

(Ref. SAE No. 070122)

Example assembly No. C35316x4

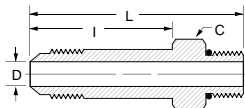
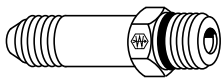

Tube O.D.	Port Size	Catalog Number	Hex C	D	I	L
1/4	1/4	C5316x4	9/16	.172	1.39	2.08
3/8	3/8	C5316x6	11/16	.297	1.56	2.31
1/2	3/8	C5316x8x6	7/8	.297	1.56	2.38
1/2	1/2	C5316x8	7/8	.391	1.88	2.70
5/8	5/8	C5316x10	1	.484	2.09	3.04
3/4	3/4	C5316x12	1-1/4	.609	2.50	3.61
1	1	C5316x16	1-1/2	.844	2.84	3.98
1-1/4	1-1/4	C5316x20	1-7/8	1.078	3.47	4.69

Replacement O-rings page 183.

• Available in stainless steel.

Adapter

Example assembly No. C35880x4

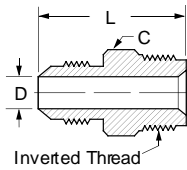
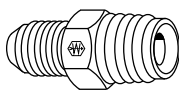

Tube O.D.	Inverted Thread	Catalog Number	Hex C	D	L
1/4	7/16-24	C5880x4	1/2	.172	1.08
5/16	1/2-20	C5880x5	9/16	.234	1.14
3/8	5/8-18	C5880x6	11/16	.297	1.22
1/2	3/4-18	C5880x8	13/16	.391	1.46

Female JIC 37° Swivel to Male Pipe Adapter

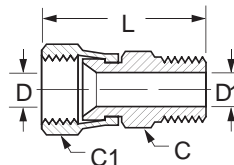
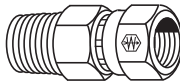

Tube O.D.	Male Pipe Size	Catalog Number	Hex C	Hex C1	D	D1	L
1/4	1/4	9100x4x4	9/16	9/16	.172	.281*	1.50
5/16	1/4	9100x5x4	11/16	5/8	.234	.281*	1.57
3/8	1/4	9100x6x4	11/16	11/16	.297	.281	1.69
3/8	3/8	9100x6x6	11/16	11/16	.297	.406*	1.69
1/2	3/8	9100x8x6	7/8	7/8	.391	.406*	1.87
1/2	1/2	9100x8x8	7/8	7/8	.391	.531*	2.05
5/8	3/8	9100x10x6	1	1	.484	.406	1.91
5/8	1/2	9100x10x8	1	1	.484	.531*	2.11
3/4	1/2	9100x12x8	1-1/8	1-1/4	.609	.531	2.21
3/4	3/4	9100x12x12	1-1/8	1-1/4	.609	.719*	2.21
1	3/4	9100x16x12	1-3/8	1-1/2	.844	.719	2.36
1	1	9100x16x16	1-3/8	1-1/2	.844	.938*	2.55
1-1/4	1-1/4	9100x20x20	1-7/8	2	1.078	1.250*	2.73

*Optional counterbore for D1.

Male JIC 37° to Male Metric Standpipe

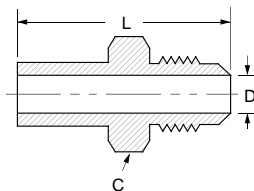
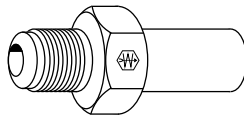

Tube O.D.	Tube O.D. (mm)	Catalog Number	Hex C	L	D
1/4	6MM	MC5019x4x6	9/16	1.58	.16
1/4	8MM	MC5019x4x8	9/16	1.68	.17
3/8	10MM	MC5019x6x10	3/4	1.67	.28
1/2	12MM	MC5019x8x12	7/8	1.97	.32
1/2	14MM	MC5019x8x14	7/8	1.89	.39
5/8	15MM	MC5019x10x15	1	2.03	.43
5/8	16MM	MC5019x10x16	1	2.07	.47
3/4	16MM	MC5019x12x16	1-1/4	2.22	.47
3/4	18MM	MC5019x12x18	1-1/4	2.12	.55
3/4	20MM	MC5019x12x20	1-1/4	2.38	.61
1	22MM	MC5019x16x22	1-1/2	2.21	.67
1	25MM	MC5019x16x25	1-1/2	2.54	.79

For metric flareless nuts and sleeves see page 211.

Male JIC 37° to O-Ring Port Adapter

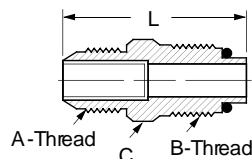
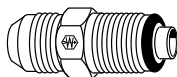

Tube Size	Port Size	Catalog Number	Replacement O-Ring	Thread A	Thread B	Hex C	L
1/4	1/4	41157x4	7629x1	7/16-20	7/16-24	7/16	1.33
3/8	3/8	41157x6	7629x3	9/16-18	5/8-18	5/8	1.47
1/2	1/2	41157x8	7629x5	3/4-16	3/4-16	3/4	1.91
5/8	5/8	41157x10	7629x7	7/8-14	7/8-14	15/16	2.23
3/4	3/4	41157x12	7629x8	1-1/16-12	1-1/16-16	1-1/8	2.13

90° Elbow - Female JIC 37° Swivel to Male Straight Thread O-Ring

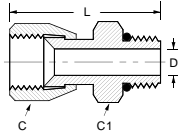
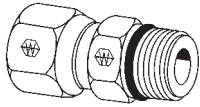

For replacement Straight Thread O-rings, see page 183.

Tube O.D.	Port Size	Catalog Number	Hex C	Hex C1	L	D
1/4	1/4	C5216x4x4	9/16	9/16	1.32	.17
1/4	3/8	C5216x4x6	11/16	11/16	1.37	.17
3/8	3/8	C5216x6x6	11/16	11/16	1.51	.30
3/8	1/2	C5216x6x8	11/16	7/8	1.58	.30
1/2	3/8	C5216x8x6	7/8	3/4	1.62	.30
1/2	1/2	C5216x8x8	7/8	7/8	1.61	.39
5/8	5/8	C5216x10x10	1	1	1.96	.48
3/4	3/4	C5216x12x12	1-1/4	1-1/4	2.17	.61
1	1	C5216x16x16	1-1/2	1-1/2	2.30	.84
1-1/4	1-1/4	C5216x20x20	2	1-7/8	2.47	1.08
1-1/2	1-1/2	C5216x24x24	2-1/8	2-1/8	2.63	1.31
2	2	C5216x32x32	2-3/4	2-3/4	2.95	1.78

Female JIC 37° Swivel to Female Pipe

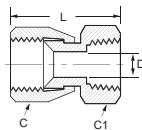
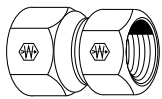

Tube O.D.	Female Pipe	Catalog Number	Hex C	Hex C1	L	D
1/4	1/4	C5256x4x4	9/16	3/4	1.32	.172
3/8	3/8	C5256x6x6	11/16	7/8	1.63	.297
1/2	1/2	C5256x8x8	7/8	1-1/8	1.81	.391
3/4	3/4	C5256x12	1-1/4	1-1/4	2.08	.609
1	1	C5256x16	1-1/2	1-1/2	2.62	.844

**45° Male Elbow
Stainless Steel No. 5367x
(Ref. SAE No. 070302)
Example assembly No. C35355x4**

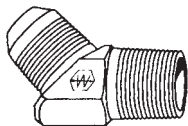
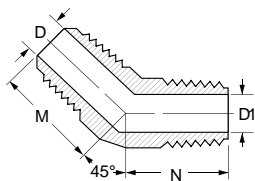
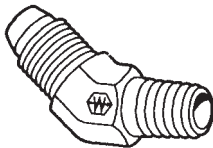

Tube O.D.	Male Pipe Thread	Catalog Number	D	D1	M	N	Across Flats
1/8	1/8	C5355x2	.062	.188	.66	.52	7/16
3/16	1/8	C5355x3	.125	.188	.66	.52	7/16
1/4	1/8	C5355x4	.172	.188	.72	.64	7/16
1/4	1/4	C5355x4x4*	.172	.281	.83	.86	9/16
5/16	1/8	C5355x5	.234	.188	.77	.67	9/16
5/16	1/4	C5355x5x4	.234	.281	.83	.86	9/16
3/8	1/8	C5355x6x2	.297	.188	.83	.69	9/16
3/8	1/4	C5355x6*	.297	.281	.83	.86	9/16
3/8	3/8	C5355x6x6	.297	.406	.98	.95	3/4
3/8	1/2	C5355x6x8	.297	.531	1.06	1.17	7/8
1/2	1/4	C5355x8x4	.391	.281	.98	.95	3/4
1/2	3/8	C5355x8*	.391	.406	.98	.95	3/4
1/2	1/2	C5355x8x8*	.391	.531	.99	1.17	7/8
5/8	3/8	C5355x10x6	.484	.406	1.11	1.00	7/8
5/8	1/2	C5355x10	.484	.531	1.11	1.17	7/8
3/4	1/2	C5355x12x8	.609	.531	1.28	1.20	1-1/16
3/4	3/4	C5355x12*	.609	.719	1.28	1.20	1-1/16
1	3/4	C5355x16x12	.844	.719	1.47	1.27	1-5/16
1	1	C5355x16	.844	.938	1.47	1.48	1-5/16
1-1/2	1-1/2	C5355x24	1.312	1.500	1.78	1.77	1-7/8
1/8	1/8	TF5355x2	.062	.188	.66	.52	7/16
1/4	1/8	TF5355x4	.172	.188	.72	.64	1/2
1/4	1/4	TF5355x4x4	.172	.281	.81	.86	5/8
5/16	1/8	TF5355x5	.234	.188	.76	.64	9/16
5/16	1/4	TF5355x5x4	.234	.281	.83	.86	5/8
3/8	1/8	TF5355x6x2	.297	.188	.81	.66	5/8
3/8	1/4	TF5355x6	.297	.281	.82	.86	5/8
3/8	3/8	TF5355x6x6	.297	.406	.91	.95	13/16
3/8	1/2	TF5355x6x8	.297	.531	1.03	1.17	15/16
1/2	1/4	TF5355x8x4	.391	.281	.98	.94	13/16
1/2	3/8	TF5355x8	.391	.406	.98	.95	13/16
1/2	1/2	TF5355x8x8	.391	.531	1.12	1.17	15/16
5/8	3/8	TF5355x10x6	.484	.406	1.11	1.06	15/16
5/8	1/2	TF5355x10	.484	.531	1.11	1.17	15/16
5/8	3/4	TF5355x10x12	.484	.719	1.26	1.20	1-1/8
3/4	1/2	TF5355x12x8	.609	.531	1.28	1.17	1-1/8
3/4	3/4	TF5355x12	.609	.719	1.28	1.20	1-1/8
3/4	1	TF5355x12x16	.609	.938	1.42	1.48	1-3/8
1	3/4	TF5355x16x12	.844	.719	1.47	1.28	1-3/8
1	1	TF5355x16	.844	.938	1.47	1.48	1-3/8
1-1/4	1-1/4	TF5355x20	1.078	1.250	1.59	1.67	1-3/4
1-1/2	1-1/2	TF5355x24	1.312	1.500	1.78	1.77	2
2	2	TF5355x32	1.781	1.938	2.22	2.11	2-5/8

* Available in stainless steel.

45° Elbow - Swivel Nut
 Stainless Steel No. **5368x**
 (Ref. SAE No. 070321)
 Example assembly No. C35356x4

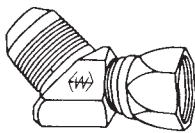
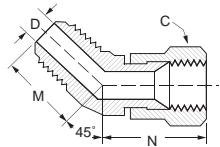
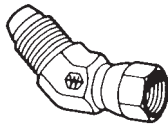

Tube O.D.	Catalog Number	Hex C	D	M	N	Across Flats
1/4	C5356x4	9/16	.172	.72	.94	7/16
5/16	C5356x5*	5/8	.234	.77	1.00	9/16
3/8	C5356x6*	11/16	.297	.83	1.12	9/16
1/2	C5356x8*	7/8	.391	.98	1.28	3/4
5/8	C5356x10	1	.484	1.11	1.44	7/8
3/4	C5356x12	1-1/4	.609	1.28	1.50	1-1/16
7/8	C5356x14	1-3/8	.718	1.39	1.62	1-5/16
1	C5356x16	1-1/2	.845	1.47	1.75	1-5/16
1-1/4	C5356x20*	2	1.078	1.59	2.03	1-5/8
1-1/2	C5356x24	2-1/4	1.312	1.78	2.25	1-7/8
1/4	TF5356x4	9/16	.172	.72	.94	1/2
5/16	TF5356x5	5/8	.234	.77	1.00	9/16
3/8	TF5356x6	11/16	.297	.83	1.12	5/8
1/2	TF5356x8	7/8	.391	.98	1.28	13/16
5/8	TF5356x10	1	.484	1.11	1.44	15/16
3/4	TF5356x12	1-1/4	.609	1.28	1.50	1-1/8
1	TF5356x16	1-1/2	.845	1.47	1.75	1-3/8
1-1/4	TF5356x20	2	1.078	1.59	2.03	1-3/4
1-1/2	TF5356x24	2-1/4	1.312	1.78	2.25	2
2	TF5356x32	2-7/8	1.781	2.22	2.91	2-5/8

*Special Order Only

45° Bulkhead Union Elbow
 (Ref. SAE No. 070801)

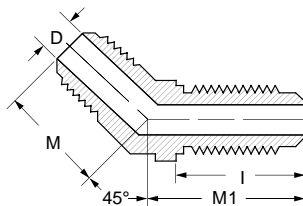
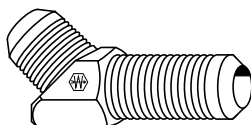

Tube O.D.	Catalog Number	D	M	M1	Across Flats	I
1/4	TF5375x4	.172	.72	1.53	1/2	1.11
5/16	TF5375x5	.234	.76	1.53	9/16	1.11
3/8	TF5375x6	.297	.83	1.67	5/8	1.18
1/2	TF5375x8	.391	.98	1.94	13/16	1.38
5/8	TF5375x10	.484	1.11	2.17	15/16	1.52
3/4	TF5375x12	.609	1.28	2.44	1-1/8	1.69
1	TF5375x16	.844	1.47	2.56	1-3/8	1.69

For Bulkhead nut see page 167. Included with assembly.

• Available in stainless steel.

STEEL

**45° Elbow - Straight Thread
O-Ring**
(Ref. SAE No. 070320)
Example assembly No. C35365x4

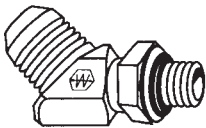
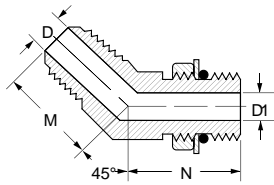
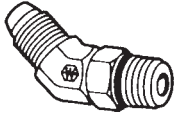

Replacement O-rings page 183.
*Special Order Only.

Tube O.D.	Port Size	Catalog Number	D	D1	M	N	Across Flats
1/4	1/4	C5365x4	.172	.172	.72	1.05	7/16
5/16	5/16	C5365x5	.234	.234	.77	1.05	9/16
3/8	3/8	C5365x6	.297	.297	.83	1.14	9/16
1/2	1/2	C5365x8	.391	.391	.98	1.30	3/4
1/2	5/8	C5365x8x10	.391	.484	.99	1.52	7/8
5/8	5/8	C5365x10	.484	.484	1.11	1.52	7/8
3/4	5/8	C5365x12x10	.609	.484	1.28	1.57	1-1/16
3/4	3/4	C5365x12	.609	.609	1.28	1.73	1-1/16
1	1	C5365x16	.844	.844	1.47	1.86	1-5/16
1-1/4	1-1/4	C5365x20	1.078	1.078	1.59	1.91	1-5/8
1-1/2	1-1/2	C5365x24*	1.312	1.312	1.78	1.91	1-7/8
1/4	1/4	TF5365x4	.172	.172	.72	1.05	1/2
5/16	5/16	TF5365x5	.234	.234	.77	1.05	9/16
3/8	3/8	TF5365x6	.297	.297	.83	1.14	5/8
3/8	1/2	TF5365x6x8	.297	.391	.87	1.30	13/16
1/2	3/8	TF5365x8x6	.391	.297	.98	1.17	13/16
1/2	1/2	TF5365x8	.391	.391	.98	1.30	13/16
1/2	5/8	TF5365x8x10	.391	.484	.99	1.52	15/16
5/8	1/2	TF5365x10x8	.484	.391	1.09	1.41	15/16
5/8	5/8	TF5365x10	.484	.484	1.09	1.52	15/16
5/8	3/4	TF5365x10x12	.484	.609	1.22	1.73	1-1/8
3/4	5/8	TF5365x12x10	.609	.484	1.30	1.58	1-1/8
3/4	3/4	TF5365x12	.609	.609	1.28	1.73	1-1/8
3/4	1	TF5365x12x16	.609	.844	1.45	1.86	1-3/8
7/8	7/8	TF5365x14	.718	.718	1.39	1.80	1-1/4
1	3/4	TF5365x16x12	.844	.609	1.47	1.86	1-3/8
1	1	TF5365x16	.844	.844	1.47	1.86	1-3/8
1-1/4	1-1/4	TF5365x20	1.078	1.250	1.59	1.91	1-3/4
1-1/2	1-1/2	TF5365x24	1.312	1.312	1.78	1.91	2
2	2	TF5365x32	1.781	1.938	2.22	1.86	2-5/8

90° Union Elbow
Stainless Steel No. 5517x
(Ref. SAE No. 070201)
Example assembly No. C35505x4

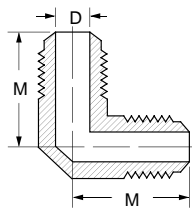
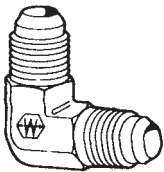

*Special Order Only

Tube O.D.	Catalog Number	D	M	Across Flats
1/4	C5505x4*	.172	.89	7/16
5/16	C5505x5*	.234	.95	9/16
3/8	C5505x6*	.297	1.06	9/16
1/2	C5505x8*	.391	1.25	3/4
5/8	C5505x10*	.484	1.45	7/8
3/4	C5505x12*	.609	1.66	1-1/16
1	C5505x16*	.844	1.81	1-5/16
1-1/4	C5505x20*	1.078	2.06	1-5/8
1-1/2	C5505x24*	1.312	2.33	1-7/8
1/4	TF5505x4	.172	.89	1/2
5/16	TF5505x5	.234	.95	1/2
3/8	TF5505x6	.297	1.06	5/8
1/2	TF5505x8	.391	1.25	13/16
5/8	TF5505x10	.484	1.45	15/16
3/4	TF5505x12	.609	1.66	1-1/8
7/8	TF5505x14	.718	1.73	1-1/4
1	TF5505x16	.844	1.81	1-3/8
1-1/4	TF5505x20	1.078	2.06	1-3/4
1-1/2	TF5505x24	1.312	2.33	2
2	TF5505x32	1.781	3.06	2-5/8

• Available in stainless steel.

90° Male Elbow
Stainless Steel No. 5417x
 (Ref. SAE No. 070202)
 Example assembly No. C35405x4

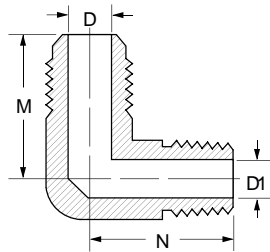
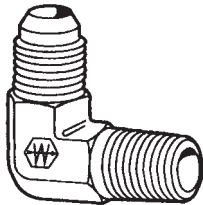

Tube O.D.	Male Pipe Thread	Catalog Number	D	D1	M	N	Across Flats
1/8	1/8	C5405x2•	.062	.188	.77	.72	7/16
3/16	1/8	C5405x3	.125	.188	.83	.72	7/16
1/4	1/8	C5405x4•	.172	.188	.89	.78	7/16
1/4	1/4	C5405x4x4•	.172	.281	1.05	1.09	9/16
5/16	1/8	C5405x5	.234	.188	.95	.78	9/16
5/16	1/4	C5405x5x4•	.234	.281	1.05	1.09	9/16
3/8	1/8	C5405x6x2•	.297	.188	1.06	.90	9/16
3/8	1/4	C5405x6•	.297	.281	1.06	1.09	9/16
3/8	3/8	C5405x6x6•	.297	.406	1.14	1.22	3/4
3/8	1/2	C5405x6x8•	.297	.531	1.22	1.47	7/8
1/2	1/4	C5405x8x4•	.391	.281	1.25	1.22	3/4
1/2	3/8	C5405x8•	.391	.406	1.25	1.22	3/4
1/2	1/2	C5405x8x8•	.391	.531	1.33	1.47	7/8
1/2	3/4	C5405x8x12•	.391	.719	1.42	1.59	1-1/16
5/8	3/8	C5405x10x6	.484	.406	1.45	1.28	7/8
5/8	1/2	C5405x10•	.484	.531	1.45	1.47	7/8
5/8	3/4	C5405x10x12	.484	.719	1.54	1.59	1-1/16
3/4	1/2	C5405x12x8•	.609	.531	1.66	1.59	1-1/16
3/4	3/4	C5405x12	.609	.719	1.66	1.59	1-1/16
7/8	3/4	C5405x14*	.719	.719	1.73	1.69	1-5/16
1	3/4	C5405x16x12	.844	.719	1.81	1.78	1-5/16
1	1	C5405x16•	.844	.938	1.81	1.97	1-5/16
1-1/4	1	C5405x20x16	1.078	.938	2.06	2.38	1-5/8
1-1/4	1-1/4	C5405x20	1.078	1.250	2.06	2.38	1-5/8
1-1/2	1-1/2	C5405x24	1.312	1.500	2.33	2.64	1-7/8
2	2	C5405x32	1.781	1.938	3.06	3.00	2-9/16
1/4	1/8	TF5405x4	.172	.188	.89	.78	1/2
1/4	1/4	TF5405x4x4	.172	.281	.95	1.09	5/8
1/4	3/8	TF5405x4x6	.172	.406	1.05	1.22	13/16
1/4	1/2	TF5405x4x8	.172	.531	1.11	1.47	15/16
5/16	1/8	TF5405x5	.234	.188	.95	.78	9/16
5/16	1/4	TF5405x5x4	.234	.281	.98	1.09	5/8
5/16	3/8	TF5405x5x6	.234	.406	1.08	1.22	13/16
3/8	1/8	TF5405x6x2	.297	.188	1.06	.81	5/8
3/8	1/4	TF5405x6	.297	.281	1.06	1.09	5/8
3/8	3/8	TF5405x6x6	.297	.406	1.16	1.22	13/16
3/8	1/2	TF5405x6x8	.297	.531	1.22	1.47	15/16
3/8	3/4	TF5405x6x12	.297	.719	1.31	1.59	1-1/8
1/2	1/4	TF5405x8x4	.391	.281	1.25	1.19	13/16
1/2	3/8	TF5405x8	.391	.406	1.25	1.22	13/16
1/2	1/2	TF5405x8x8	.391	.531	1.31	1.47	15/16
1/2	3/4	TF5405x8x12	.391	.719	1.41	1.59	1-1/8
5/8	3/8	TF5405x10x6	.484	.406	1.45	1.28	15/16
5/8	1/2	TF5405x10	.484	.531	1.45	1.47	15/16
5/8	3/4	TF5405x10x12	.484	.719	1.55	1.59	1-1/8
3/4	1/2	TF5405x12x8	.609	.531	1.66	1.56	1-1/8
3/4	3/4	TF5405x12	.609	.719	1.66	1.59	1-1/8
3/4	1	TF5405x12x16	.609	.938	1.78	1.97	1-3/8
7/8	3/4	TF5405x14	.718	.719	1.73	1.69	1-1/4
1	3/4	TF5405x16x12	.844	.719	1.81	1.72	1-3/8
1	1	TF5405x16	.844	.938	1.81	1.97	1-3/8
1	1-1/4	TF5405x16x20	.844	1.250	2.00	2.37	1-3/4
1-1/4	1	TF5405x20x16	1.078	.938	2.06	2.16	1-3/4
1-1/4	1-1/4	TF5405x20	1.078	1.250	2.06	2.37	1-3/4
1-1/4	1-1/2	TF5405x20x24	1.078	1.500	2.19	2.64	2
1-1/2	1-1/4	TF5405x24x20	1.312	1.250	2.33	2.50	2
1-1/2	1-1/2	TF5405x24	1.312	1.500	2.33	2.64	2
2	2	TF5405x32	1.781	1.938	3.06	3.00	2-5/8

*Special Order Only

• Available in stainless steel.

STEEL

90° Male Elbow Long

(Ref. SAE No. 071502)

Example assembly No. C35425x4

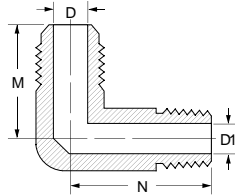
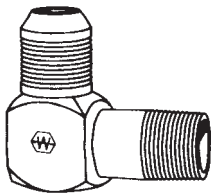
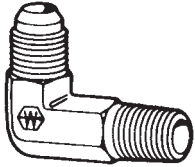

*Special Order Only.

Tube O.D.	Male Pipe Thread	Catalog Number	D	D1	M	N	Across Flats
1/4	1/4	C5425x4x4*	.172	.281	1.05	1.58	9/16
3/8	1/4	C5425x6	.297	.281	1.06	1.58	9/16
1/2	3/8	C5425x8*	.391	.406	1.25	1.82	3/4
3/4	3/4	C5425x12	.609	.719	1.66	2.44	1-1/16
1/4	1/8	TF5425x4	.172	.188	.89	1.17	1/2
1/4	1/4	TF5425x4x4	.172	.281	.95	1.58	5/8
5/16	1/4	TF5425x5x4	.234	.281	.95	1.55	9/16
3/8	1/4	TF5425x6	.297	.281	1.06	1.58	5/8
3/8	3/8	TF5425x6x6	.297	.406	1.16	1.83	13/16
1/2	3/8	TF5425x8	.391	.406	1.25	1.83	13/16
1/2	1/2	TF5425x8x8	.391	.531	1.31	2.17	15/16
1/2	3/4	TF5425x8x12	.391	.719	1.41	2.44	1-1/8
5/8	1/2	TF5425x10	.484	.531	1.45	2.17	15/16
3/4	3/4	TF5425x12	.609	.719	1.66	2.44	1-1/8
7/8	3/4	TF5425x14	.718	.719	1.73	2.66	1-1/4
1	1	TF5425x16	.844	.938	1.81	3.02	1-3/8
1-1/4	1-1/4	TF5425x20	1.078	1.250	2.06	3.69	1-3/4
1-1/2	1-1/2	TF5425x24	1.312	1.500	2.32	4.11	2

90° Male Elbow Extra Long

(Ref. SAE No. 071602)

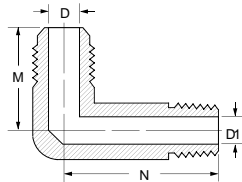
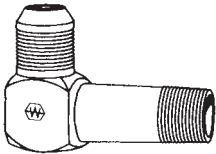

Tube O.D.	Male Pipe Thread	Catalog Number	D	D1	M	N	Across Flats
1/4	1/8	TF5435x4	.172	.188	.89	1.56	1/2
1/4	1/4	TF5435x4x4	.172	.281	.95	2.07	5/8
5/16	1/8	TF5435x5	.234	.188	.95	1.62	9/16
5/16	1/4	TF5435x5x4	.234	.281	.95	2.04	9/16
3/8	1/4	TF5435x6	.297	.281	1.06	2.08	5/8
3/8	3/8	TF5435x6x6	.297	.406	1.06	2.42	13/16
1/2	3/8	TF5435x8	.391	.406	1.25	2.42	13/16
1/2	1/2	TF5435x8x8	.391	.531	1.31	2.88	15/16
5/8	1/2	TF5435x10	.484	.531	1.45	2.88	15/16
3/4	3/4	TF5435x12	.609	.719	1.66	3.28	1-1/8
7/8	3/4	TF5435x14	.718	.719	1.73	3.62	1-1/4
1	1	TF5435x16	.844	.938	1.81	4.05	1-3/8
1-1/4	1-1/4	TF5435x20	1.078	1.250	2.06	5.00	1-3/4

90° Bulkhead Union Elbow

Stainless Steel No. 5537x

(Ref. SAE No. 070701)

Example assembly No. C35525x4

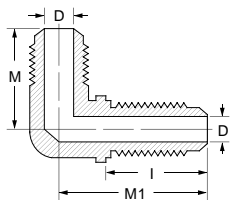
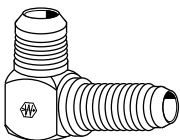
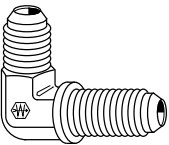

*Special Order Only.

For Bulkhead nut see page 167. Included with assembly.

Tube O.D.	Catalog Number	D	I	M	M1	Across Flats
1/4	C5525x4*	.172	1.11	.97	1.59	7/16
5/16	C5525x5*	.234	1.11	1.03	1.62	9/16
3/8	C5525x6*	.297	1.18	1.09	1.81	9/16
1/2	C5525x8	.391	1.38	1.36	2.11	3/4
5/8	C5525x10*	.484	1.52	1.56	2.39	7/8
3/4	C5525x12*	.609	1.69	1.78	2.67	1-1/16
1	C5525x16	.844	1.69	1.94	2.80	1-5/16
1-1/4	C5525x20	1.078	1.74	2.17	3.12	1-5/8
1/4	TF5525x4	.172	1.11	.97	1.59	1/2
5/16	TF5525x5	.234	1.11	1.03	1.62	9/16
3/8	TF5525x6	.297	1.18	1.09	1.81	5/8
1/2	TF5525x8	.391	1.38	1.36	2.11	13/16
5/8	TF5525x10	.484	1.52	1.56	2.39	15/16
3/4	TF5525x12	.609	1.69	1.78	2.67	1-1/8
1	TF5525x16	.844	1.69	1.94	2.80	1-3/8

• Available in stainless steel.

90° Female Elbow
Stainless Steel No. 5467x
 (Ref. SAE No. 070203)
 Example assembly No. C35455x4

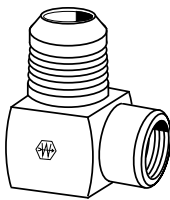
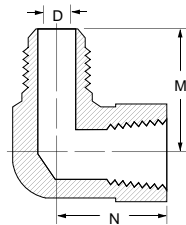
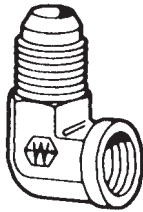

Tube O.D.	Fem. Pipe Thread	Catalog Number	D	M	N	Across Flats
1/4	1/8	C5455x4•	.172	1.08	.66	9/16
1/4	1/4	C5455x4x4*	.172	1.22	.88	3/4
5/16	1/8	C5455x5*	.234	1.08	.66	9/16
3/8	1/8	C5455x6x2	.297	1.06	.66	9/16
3/8	1/4	C5455x6•	.297	1.23	.88	3/4
3/8	3/8	C5455x6x6•	.297	1.31	1.02	7/8
1/2	1/4	C5455x8x4	.391	1.23	.88	3/4
1/2	3/8	C5455x8•	.391	1.42	1.02	7/8
1/2	1/2	C5455x8x8•	.391	1.52	1.23	1-1/16
5/8	1/2	C5455x10	.484	1.64	1.23	1-1/16
3/4	1/2	C5455x12x8	.609	1.66	1.23	1-1/16
3/4	3/4	C5455x12•	.609	1.89	1.36	1-5/16
7/8	3/4	C5455x14	.718	1.86	1.42	1-5/16
1	1	C5455x16•	.844	2.17	1.62	1-5/8
1-1/4	1-1/4	C5455x20*	1.078	2.33	1.70	1-7/8
1/4	1/8	TF5455x4	.172	1.08	.66	5/8
1/4	1/4	TF5455x4x4	.172	1.14	.88	3/4
5/16	1/8	TF5455x5	.234	1.08	.66	5/8
5/16	1/4	TF5455x5x4	.234	1.30	1.02	7/8
3/8	1/4	TF5455x6	.297	1.23	.88	3/4
3/8	3/8	TF5455x6x6	.297	1.14	.88	3/4
1/2	3/8	TF5455x8	.391	1.42	1.02	7/8
1/2	1/2	TF5455x8x8	.391	1.55	1.23	1-1/8
5/8	1/2	TF5455x10	.484	1.64	1.23	1-1/8
3/4	3/4	TF5455x12	.609	1.89	1.36	1-3/8
7/8	3/4	TF5455x14	.718	1.86	1.42	1-3/8
1	1	TF5455x16	.814	2.17	1.62	1-5/8
1-1/4	1-1/4	TF5455x20	1.078	2.33	1.70	2
1-1/2	1-1/2	TF5455x24	1.312	2.89	2.08	2-3/8
2	2	TF5455x32	1.781	3.30	2.39	2-7/8

*Special Order Only.

90° Elbow - Swivel Nut
Stainless Steel No. 5518x
 (Ref. SAE No. 070221)
 Example assembly No. C35506x4

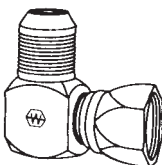
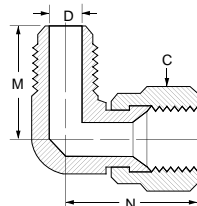
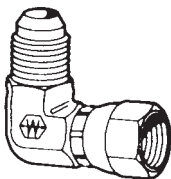

Tube O.D.	Catalog Number	Hex C	D	M	N	Across Flats
1/4	C5506x4•	9/16	.172	.89	1.00	7/16
5/16	C5506x5	5/8	.234	.95	1.06	9/16
3/8	C5506x6•	11/16	.297	1.06	1.25	9/16
1/2	C5506x8•	7/8	.391	1.25	1.42	3/4
5/8	C5506x10	1	.484	1.43	1.62	7/8
3/4	C5506x12•	1-1/4	.609	1.66	1.75	1-1/16
7/8	C5506x14*	1-3/8	.718	1.73	1.72	1-5/16
1	C5506x16•	1-1/2	.844	1.81	2.00	1-5/16
1-1/4	C5506x20	2	1.078	2.06	2.31	1-5/8
1/4	TF5506x4	9/16	.172	.89	1.00	1/2
5/16	TF5506x5	5/8	.234	.95	1.06	9/16
3/8	TF5506x6	11/16	.297	1.06	1.25	5/8
1/2	TF5506x8	7/8	.391	1.25	1.38	13/16
5/8	TF5506x10	1	.484	1.45	1.62	15/16
3/4	TF5506x12	1-1/4	.609	1.66	1.75	1-1/8
7/8	TF5506x14	1-3/8	.718	1.73	1.78	1-1/4
1	TF5506x16	1-1/2	.844	1.81	2.00	1-3/8
1-1/4	TF5506x20	2	1.078	2.06	2.31	1-3/4
1-1/2	TF5506x24	2-1/4	1.312	2.33	2.59	2
2	TF5506x32	2-7/8	1.781	3.06	3.38	2-5/8

*Special Order Only.

• Available in stainless steel.

90° Male Pipe to 37° JIC Swivel

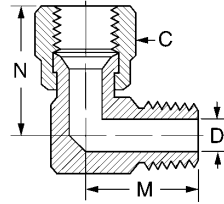
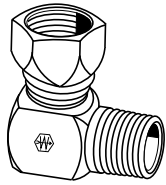

Tube O.D.	Male Pipe	Catalog Number	D	M	N	Across Flats	Hex C
1/4	1/8	TF5406x4	.188	.78	1.00	1/2	9/16
3/8	1/4	TF5406x6	.281	1.09	1.25	5/8	11/16
1/2	3/8	TF5406x8	.406	1.22	1.38	13/16	7/8
5/8	1/2	TF5406x10	.531	1.47	1.62	15/16	1
3/4	3/4	TF5406x12	.719	1.59	1.75	1-1/8	1-1/4
1	1	TF5406x16	.938	1.97	2.00	1-3/8	1-1/2
1-1/4	1-1/4	TF5406x20	1.250	2.38	2.31	1-3/4	2
1-1/2	1-1/2	TF5406x24	1.500	2.64	2.59	2	2-1/4
2	2	TF5406x32	1.938	3.00	3.38	2-5/8	2-7/8

90° Elbow - Straight Thread O-Ring

Stainless Steel No. **5527x**

(Ref. SAE No. 070220)

Example assembly No. **C35515x4**

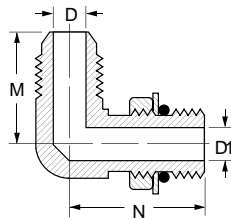
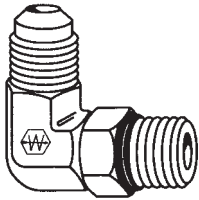

Tube O.D.	Port Size	Catalog Number	D	D1	M	N	Across Flats
3/16	3/16	C5515x3	.125	.125	.83	.94	7/16
1/4	1/4	C5515x4	.172	.172	.89	1.03	7/16
5/16	5/16	C5515x5	.234	.234	.95	1.13	9/16
3/8	3/8	C5515x6	.297	.297	1.06	1.25	9/16
3/8	1/2	C5515x6x8	.297	.391	1.14	1.45	3/4
1/2	3/8	C5515x8x6	.391	.297	1.25	1.32	3/4
1/2	1/2	C5515x8	.391	.391	1.25	1.45	3/4
1/2	5/8	C5515x8x10	.391	.484	1.33	1.70	7/8
5/8	5/8	C5515x10	.484	.484	1.45	1.70	7/8
3/4	5/8	C5515x12x10	.609	.484	1.66	1.78	1-1/16
3/4	3/4	C5515x12	.609	.609	1.66	1.94	1-1/16
7/8	7/8	C5515x14	.718	.718	1.73	2.00	1-5/16
1	3/4	C5515x16x12	.844	.609	1.81	2.05	1-5/16
1	1	C5515x16	.844	.844	1.81	2.05	1-5/16
1-1/4	1-1/4	C5515x20	1.078	1.078	2.06	2.25	1-5/8
1-1/2	1-1/2	C5515x24	1.312	1.312	2.33	2.39	1-7/8

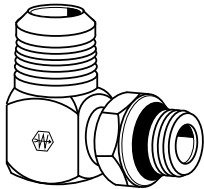

1/4	1/4	TF5515x4	.172	.172	.89	1.03	1/2
1/4	5/16	TF5515x4x5	.172	.234	.95	1.12	5/8
1/4	3/8	TF5515x4x6	.172	.297	.95	1.25	5/8
5/16	1/4	TF5515x5x4	.234	.172	.98	1.06	9/16
5/16	5/16	TF5515x5	.234	.234	.95	1.09	9/16
5/16	3/8	TF5515x5x6	.234	.297	.98	1.25	5/8
3/8	1/4	TF5515x6x4	.297	.172	1.06	1.09	5/8
3/8	5/16	TF5515x6x5	.297	.234	1.06	1.12	5/8
3/8	3/8	TF5515x6	.297	.297	1.06	1.25	5/8
3/8	1/2	TF5515x6x8	.297	.391	1.16	1.45	13/16
3/8	5/8	TF5515x6x10	.297	.484	1.22	1.70	15/16
1/2	3/8	TF5515x8x6	.391	.297	1.25	1.34	13/16
1/2	1/2	TF5515x8	.391	.391	1.25	1.45	13/16
1/2	5/8	TF5515x8x10	.391	.484	1.31	1.70	15/16
1/2	3/4	TF5515x8x12	.391	.609	1.41	1.94	1-1/8
5/8	1/2	TF5515x10x8	.484	.391	1.45	1.52	15/16
5/8	5/8	TF5515x10	.484	.484	1.45	1.70	15/16
5/8	3/4	TF5515x10x12	.484	.609	1.55	1.94	1-1/8
3/4	1/2	TF5515x12x8	.609	.391	1.66	1.61	1-1/8
3/4	5/8	TF5515x12x10	.609	.484	1.66	1.80	1-1/8
3/4	3/4	TF5515x12	.609	.609	1.66	1.94	1-1/8
3/4	7/8	TF5515x12x14	.609	.718	1.72	2.00	1-1/4
3/4	1	TF5515x12x16	.609	.844	1.78	2.05	1-3/8
7/8	7/8	TF5515x14	.718	.718	1.73	2.00	1-5/16
1	3/4	TF5515x16x12	.844	.609	1.81	2.06	1-3/8
1	7/8	TF5515x16x14	.844	.718	1.81	2.06	1-3/8
1	1	TF5515x16	.844	.844	1.81	2.05	1-3/8
1	1-1/4	TF5515x16x20	.844	1.078	2.00	2.25	1-3/4
1-1/4	1	TF5515x20x16	1.078	.844	2.06	2.23	1-3/4
1-1/4	1-1/4	TF5515x20	1.078	1.078	2.06	2.25	1-3/4
1-1/2	1-1/4	TF5515x24x20	1.312	1.078	2.33	2.37	2
1-1/2	1-1/2	TF5515x24	1.312	1.312	2.33	2.39	2
2	2	TF5515x32	1.781	1.781	3.06	2.89	2-5/8

Replacement O-rings page 183.

• Available in stainless steel.

90° Elbow Long - Straight Thread O-Ring (Ref. SAE No. 071520)

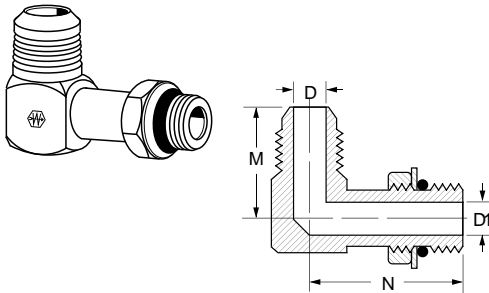

Replacement O-rings page 183.

Tube O.D.	Port Size	Catalog Number	D	D1	M	N	Across Flats
3/8	3/8	TF5515x6L	.297	.297	1.06	1.66	5/8
1/2	1/2	TF5515x8L	.391	.391	1.25	1.81	13/16
5/8	5/8	TF5515x10L	.484	.484	1.45	2.16	15/16
3/4	3/4	TF5515x12L	.609	.609	1.66	2.47	1-1/8

90° Elbow Extra Long - Straight Thread O-Ring (Ref. SAE No. 071620)

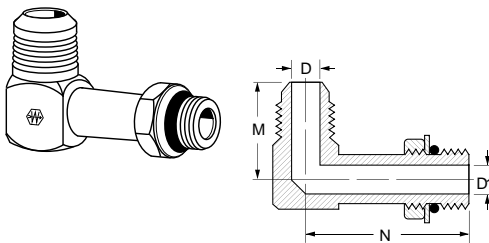

Replacement O-rings page 183.

Tube O.D.	Port Size	Catalog Number	D	D1	M	N	Across Flats
3/8	3/8	TF5515x6LL	.297	.297	1.06	2.08	5/8
1/2	1/2	TF5515x8LL	.391	.391	1.25	2.50	13/16
5/8	5/8	TF5515x10LL	.484	.484	1.45	3.25	15/16
3/4	3/4	TF5515x12LL	.609	.609	1.66	3.34	1-1/8

Union Tee Stainless Steel No. 5717x (Ref. SAE No. 070401) Assembly No. C35705x4

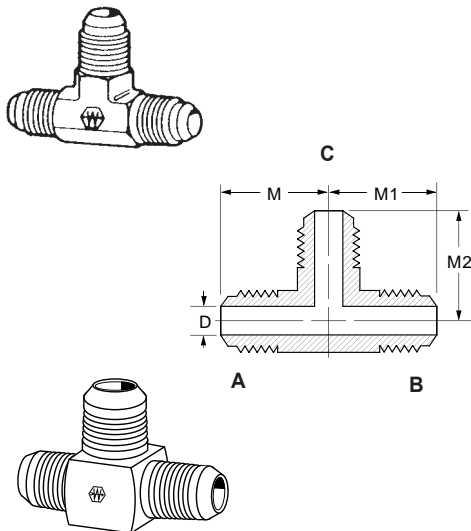

*Special Order Only.

Tube O.D. A	Tube O.D. B	Tube O.D. C	Catalog Number	D	M	M1	M2	Across Flats
1/8	1/8	1/8	C5705x2	.062	.77	.77	.77	7/16
3/16	3/16	3/16	C5705x3	.125	.83	.83	.83	7/16
1/4	1/4	1/4	C5705x4*	.172	.89	.89	.89	7/16
5/16	5/16	5/16	C5705x5*	.234	.95	.95	.95	9/16
3/8	3/8	3/8	C5705x6*	.297	1.06	1.06	1.06	9/16
1/2	1/2	1/2	C5705x8*	.391	1.25	1.25	1.25	3/4
5/8	5/8	5/8	C5705x10*	.484	1.45	1.45	1.45	7/8
3/4	3/4	3/4	C5705x12*	.609	1.66	1.66	1.66	1-1/16
7/8	7/8	7/8	C5705x14	.718	1.73	1.73	1.73	1-5/16
1	1	1	C5705x16	.844	1.81	1.81	1.81	1-5/16
1-1/4	1-1/4	1-1/4	C5705x20	1.078	2.06	2.06	2.06	1-5/8
1-1/2	1-1/2	1-1/2	C5705x24	1.312	2.33	2.33	2.33	1-7/8
1/4	1/4	1/4	TF5705x4	.172	.89	.89	.89	1/2
5/16	5/16	5/16	TF5705x5	.234	.95	.95	.95	1/2
3/8	3/8	3/8	TF5705x6	.297	1.06	1.06	1.06	5/8
1/2	1/2	1/2	TF5705x8	.391	1.25	1.25	1.25	13/16
5/8	1/2	1/2	TF5705x10x8x8	.484	1.45	1.31	1.31	15/16
5/8	5/8	5/8	TF5705x10	.484	1.45	1.45	1.45	15/16
5/8	5/8	1/2	TF5705x10x10x8	.484	1.45	1.45	1.31	15/16
3/4	3/4	3/4	TF5705x12	.609	1.66	1.66	1.66	1-1/8
7/8	7/8	7/8	TF5705x14	.718	1.73	1.73	1.73	1-1/4
1	1	1	TF5705x16	.844	1.81	1.81	1.81	1-3/8
1-1/4	1-1/4	1-1/4	TF5705x20	1.078	2.06	2.06	2.06	1-3/4
1-1/2	1-1/2	1-1/2	TF5705x24	1.312	2.33	2.33	2.33	1-7/8
2	2	2	TF5705x32	1.781	3.06	3.06	3.06	2-5/8

• Available in stainless steel.

Male Run Tee
Stainless Steel No. **5767x**
(Ref. SAE No. 070424)
Example assembly No. **C35755x4**

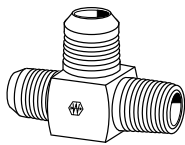
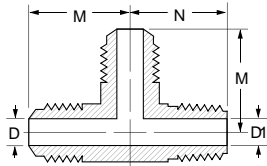
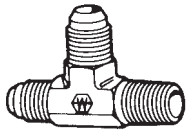

*Special Order Only

Tube O.D.	Male Pipe Thread	Catalog Number	D	D1	M	N	Across Flats
1/4	1/8	C5755x4•	.172	.188	.89	.78	7/16
1/4	1/4	C5755x4x4x4*	.172	.281	1.05	1.09	9/16
1/2	3/8	C5755x8•	.391	.406	1.25	1.22	3/4
1/2	1/2	C5755x8x8x8*	.391	.531	1.33	1.47	7/8
5/8	1/2	C5755x10	.484	.531	1.45	1.47	7/8
3/4	3/4	C5755x12	.609	.719	1.66	1.59	1-1/16
1	1	C5755x16	.844	.938	1.81	1.97	1-5/16
1/4	1/8	TF5755x4	.172	.188	.89	.78	1/2
1/4	1/4	TF5755x4x4x4	.172	.281	.95	1.09	9/16
5/16	1/8	TF5755x5	.234	.188	.95	.78	1/2
3/8	1/4	TF5755x6	.297	.281	1.06	1.09	9/16
3/8	3/8	TF5755x6x6x6	.297	.406	1.16	1.22	9/16
1/2	3/8	TF5755x8	.391	.406	1.25	1.22	13/16
1/2	1/2	TF5755x8x8x8	.391	.531	1.31	1.47	7/8
5/8	1/2	TF5755x10	.484	.531	1.45	1.47	15/16
3/4	3/4	TF5755x12	.609	.719	1.66	1.59	1-1/8
7/8	3/4	TF5755x14	.718	.719	1.73	1.69	1-1/4
1	1	TF5755x16	.844	.938	1.81	1.97	1-3/8
1-1/4	1-1/4	TF5755x20	1.078	1.250	2.06	2.38	1-3/4
1-1/2	1-1/2	TF5755x24	1.312	1.500	2.33	2.64	2
2	2	TF5755x32	1.781	1.938	3.06	3.00	2-5/8

Female Run Tee
(Ref. SAE No. 070426)

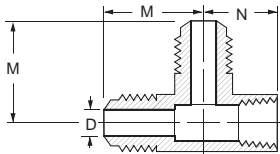
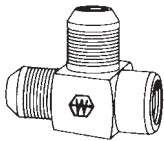

Tube O.D.	Fem. Pipe Thread	Catalog Number	D	M	N	Across Flats
1/4	1/8	TF5805x4	.172	1.08	.66	5/8
3/8	1/4	TF5805x6	.297	1.23	.88	3/4
1/2	3/8	TF5805x8	.391	1.42	1.02	7/8
5/8	1/2	TF5805x10	.484	1.64	1.23	1-1/8
3/4	3/4	TF5805x12	.609	1.89	1.36	1-3/8
7/8	3/4	TF5805x14	.718	1.86	1.42	1-3/8
1	1	TF5805x16	.844	2.17	1.62	1-5/8

Swivel Nut Run Tee
Stainless Steel No. **5718x**
(Ref. SAE No. 070432)
Example assembly No. **C35706x4**

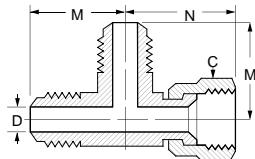
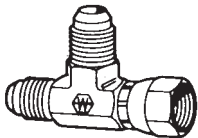

Tube O.D.	Catalog Number	Hex C	D	M	N	Across Flats
1/4	C5706x4•	9/16	.172	.89	1.00	7/16
5/16	C5706x5	5/8	.234	.95	1.06	9/16
3/8	C5706x6•	11/16	.297	1.06	1.25	9/16
1/2	C5706x8•	7/8	.391	1.25	1.44	3/4
5/8	C5706x10	1	.484	1.45	1.62	7/8
3/4	C5706x12•	1-1/4	.609	1.66	1.75	1-1/16
1	C5706x16	1-1/2	.844	1.81	2.00	1-5/16
1-1/4	C5706x20	2	1.078	2.06	2.36	1-5/8
1/4	TF5706x4	9/16	.172	.89	1.00	1/2
5/16	TF5706x5	5/8	.234	.95	1.06	9/16
3/8	TF5706x6	11/16	.297	1.06	1.25	5/8
1/2	TF5706x8	7/8	.391	1.25	1.38	13/16
5/8	TF5706x10	1	.484	1.45	1.62	15/16
3/4	TF5706x12	1-1/4	.609	1.66	1.75	1-1/8
7/8	TF5706x14	1-3/8	.719	1.73	1.78	1-1/4
1	TF5706x16	1-1/2	.844	1.81	2.00	1-3/8
1-1/4	TF5706x20	2	1.078	2.06	2.31	1-3/4
1-1/2	TF5706x24	2-1/4	1.312	2.33	2.59	2
2	TF5706x32	2-7/8	1.781	3.06	3.38	2-5/8

• Available in stainless steel.

Bulkhead Run Tee

(Ref. SAE No. 070958)

Example assembly No. C35726x6

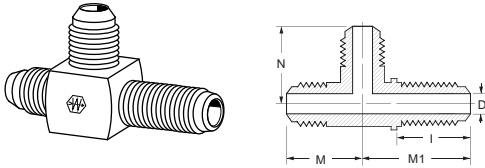

For Bulkhead nut see page 167.
Included with assembly.

Tube O.D.	Catalog Number	D	I	N	M	M1	Across Flats
3/8	C5726x6	.297	1.18	1.09	1.06	1.81	9/16
1/2	TF5726x8	.391	1.38	1.36	1.36	2.11	3/4

Straight Thread O-Ring Run Tee

(Ref. SAE No. 070428)

Example assembly No. C35716x4

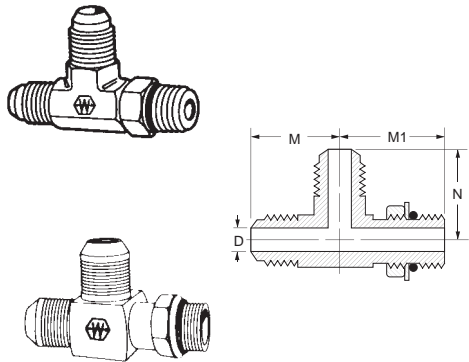

Replacement O-rings page 183.

Tube O.D.	Port Size	Catalog Number	D	M	M1	Across Flats	N
1/4	1/4	C5716x4	.172	.89	1.03	7/16	.89
5/16	5/16	C5716x5	.234	.95	1.09	9/16	.95
3/8	3/8	C5716x6	.297	1.06	1.25	9/16	1.06
1/2	1/2	C5716x8	.391	1.25	1.45	3/4	1.25
5/8	5/8	C5716x10	.484	1.45	1.70	7/8	1.45
3/4	3/4	C5716x12	.609	1.66	1.94	1-1/16	1.66
1	1	C5716x16	.844	1.81	2.05	1-5/16	1.81
1-1/4	1-1/4	C5716x20	1.078	2.06	2.25	1-5/8	2.06
1/4	1/4	TF5716x4	.172	.89	1.03	1/2	.89
5/16	5/16	TF5716x5	.234	.95	1.09	9/16	.95
3/8	3/8	TF5716x6	.297	1.06	1.25	5/8	1.06
1/2	1/2	TF5716x8	.391	1.25	1.45	13/16	1.25
5/8	5/8	TF5716x10	.484	1.45	1.70	15/16	1.45
3/4	3/4	TF5716x12	.609	1.66	1.94	1-1/8	1.66
7/8	7/8	TF5716x14	.718	1.73	2.00	1-1/4	1.73
1	1	TF5716x16	.844	1.81	2.05	1-3/8	1.81
1-1/4	1-1/4	TF5716x20	1.078	2.06	2.25	1-3/4	2.06
1-1/2	1-1/2	TF5716x24	1.312	2.33	2.39	2	2.33

Male Branch Tee

Stainless Steel No. 5617x

(Ref. SAE No. 070425)

Example assembly No. C35605x4

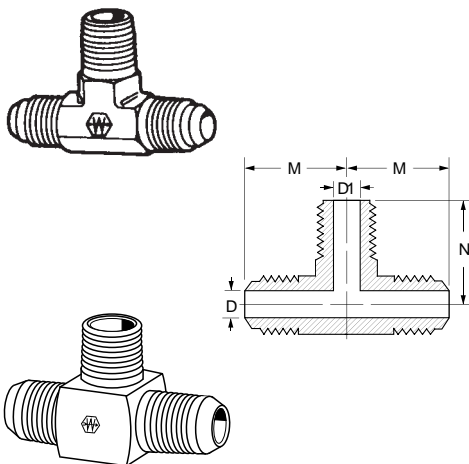

*Special Order Only

Tube O.D.	Male Pipe Thread	Catalog Number	D	D1	M	N	Across Flats
1/4	1/8	C5605x4*	.172	.188	.89	.78	7/16
1/4	1/4	C5605x4x4x4	.172	.281	1.05	1.09	9/16
5/16	1/8	C5605x5	.234	.188	.95	.78	9/16
3/8	1/4	C5605x6*	.297	.281	1.06	1.09	9/16
1/2	3/8	C5605x8	.391	.406	1.25	1.22	3/4
5/8	1/2	C5605x10	.484	.531	1.45	1.47	7/8
3/4	3/4	C5605x12	.609	.719	1.66	1.59	1-1/16
7/8	3/4	C5605x14*	.718	.719	1.73	1.69	1-5/16
1	1	C5605x16	.844	.938	1.81	1.97	1-5/16
1-1/4	1-1/4	C5605x20*	1.078	1.250	2.06	2.38	1-5/8
1/4	1/8	TF5605x4	.172	.188	.89	.78	1/2
1/4	1/4	TF5605x4x4x4	.172	.281	.95	1.09	5/8
5/16	1/8	TF5605x5	.234	.188	.95	.78	9/16
3/8	1/4	TF5605x6	.297	.281	1.08	1.09	5/8
3/8	3/8	TF5605x6x6x6	.297	.406	1.16	1.22	13/16
1/2	3/8	TF5605x8	.391	.406	1.25	1.22	13/16
1/2	1/2	TF5605x8x8x8	.391	.531	1.31	1.47	15/16
5/8	1/2	TF5605x10	.484	.531	1.45	1.47	15/16
3/4	3/4	TF5605x12	.609	.719	1.66	1.59	1-1/8
7/8	3/4	TF5605x14	.718	.719	1.73	1.69	1-1/4
1	1	TF5605x16	.844	.938	1.81	1.97	1-3/8
1-1/4	1-1/4	TF5605x20	1.078	1.250	2.06	2.38	1-3/4
1-1/2	1-1/2	TF5605x24	1.312	1.500	2.33	2.64	2
2	2	TF5605x32	1.781	1.938	3.06	3.00	2-5/8

• Available in stainless steel.

Female Branch Tee

Stainless Steel No. 5667x

(Ref. SAE No. 070427)

Example assembly No. C35655x4

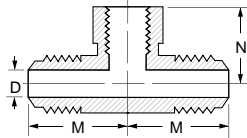
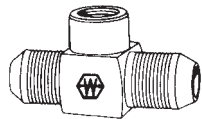
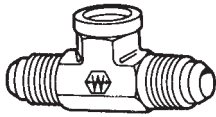

*Special Order Only

Tube O.D.	Fem. Pipe Thread	Catalog Number	D	M	N	Across Flats
1/4	1/8	C5655x4*	.172	1.08	.66	9/16
3/8	1/4	C5655x6*	.297	1.23	.88	3/4
1/2	3/8	C5655x8*	.391	1.42	1.02	7/8
5/8	1/2	C5655x10	.484	1.64	1.23	1-1/16
3/4	3/4	C5655x12	.609	1.89	1.36	1-5/16
1	1	C5655x16*	.844	2.17	1.62	1-5/8
1/4	1/8	TF5655x4	.172	1.08	.66	5/8
1/4	1/4	TF5655x4x4x4	.172	1.14	.88	3/4
5/16	1/8	TF5655x5	.234	1.08	.66	5/8
3/8	1/4	TF5655x6	.297	1.23	.88	3/4
3/8	3/8	TF5655x6x6x6	.297	1.30	1.02	7/8
1/2	3/8	TF5655x8	.391	1.42	1.02	7/8
1/2	1/2	TF5655x8x8x8	.391	1.55	1.23	1-1/8
5/8	1/2	TF5655x10	.484	1.64	1.23	1-1/8
3/4	3/4	TF5655x12	.609	1.89	1.36	1-3/8
7/8	3/4	TF5655x14	.718	1.86	1.42	1-3/8
1	1	TF5655x16	.844	2.17	1.62	1-5/8
1-1/4	1-1/4	TF5655x20	1.078	2.33	1.70	2
1-1/2	1-1/2	TF5655x24	1.312	2.89	2.08	2-3/8
2	2	TF5655x32	1.781	3.30	2.39	2-7/8

Swivel Nut Branch Tee

Stainless Steel No. 5719x

(Ref. SAE No. 070433)

Example assembly No. C35707x4

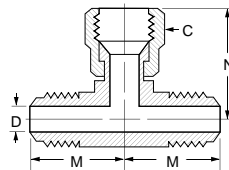
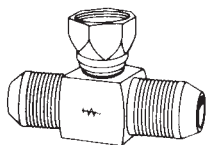
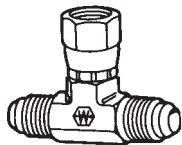

*Special Order Only

Tube O.D.	Catalog Number	Hex C	D	M	N	Across Flats
1/4	C5707x4*	9/16	.172	.89	1.00	7/16
3/8	C5707x6*	11/16	.297	1.06	1.25	9/16
1/2	C5707x8*	7/8	.391	1.25	1.43	3/4
5/8	C5707x10*	1	.484	1.45	1.62	7/8
3/4	C5707x12*	1-1/4	.609	1.66	1.75	1-1/16
1	C5707x16	1-1/2	.844	1.81	2.00	1-5/16
1/4	TF5707x4	9/16	.172	.89	1.00	7/16
5/16	TF5707x5	5/8	.234	.95	1.06	9/16
3/8	TF5707x6	11/16	.297	1.06	1.25	5/8
1/2	TF5707x8	7/8	.391	1.25	1.38	13/16
5/8	TF5707x10	1	.484	1.45	1.62	7/8
3/4	TF5707x12	1-1/4	.609	1.66	1.75	1-1/8
7/8	TF5707x14	1-3/8	.719	1.73	1.78	1-1/4
1	TF5707x16	1-1/2	.844	1.81	2.00	1-3/8
1-1/4	TF5707x20	2	1.078	2.06	2.31	2
1-1/2	TF5707x24	2-1/4	1.312	2.33	2.59	2
2	TF5707x32	2-7/8	1.781	3.06	3.38	2-5/8

Bulkhead Union Tee

(Ref. SAE No. 070959)

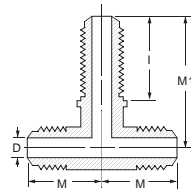
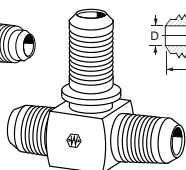
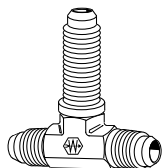

#Stainless Steel Construction

For bulkhead nut see page 167. Included with assembly.

Tube O.D.	Catalog Number	I	D	M	M1	Across Flats
1/4	TF5725x4	1.11	.172	.97	1.59	1/2
3/8	TF5725x6	1.18	.297	1.06	1.81	5/8
1/2	TF5725x8	1.38	.391	1.36	2.11	13/16
5/8	TF5725x10	1.52	.484	1.56	2.39	15/16
3/4	TF5725x12	1.69	.609	1.78	2.67	1-1/8
1	TF5725x16	1.69	.844	1.94	2.80	1-3/8
1/4	5737x4#	1.11	.172	.97	1.59	7/16
3/8	5737x6#	1.18	.297	1.09	1.81	9/16

• Available in stainless steel.

Straight Thread O-Ring Branch Tee

(Ref. SAE No. 070429)

Example assembly No. C35715x4

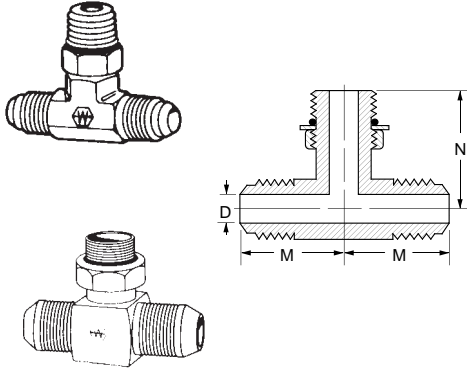

Replacement O-rings listed below.
*Special Order Only.

Tube O.D.	Port Size	Catalog Number	D	M	N	Across Flats
1/4	1/4	C5715x4	.172	.89	1.03	7/16
5/16	5/16	C5715x5*	.234	.95	1.09	9/16
3/8	3/8	C5715x6	.297	1.06	1.25	9/16
1/2	1/2	C5715x8	.391	1.25	1.45	3/4
5/8	5/8	C5715x10	.484	1.45	1.70	7/8
3/4	3/4	C5715x12	.609	1.66	1.94	1-1/16
1	1	C5715x16	.844	1.81	2.05	1-5/16
1/4	1/4	TF5715x4	.172	.89	1.03	7/16
5/16	5/16	TF5715x5	.234	.95	1.09	9/16
3/8	3/8	TF5715x6	.297	1.06	1.25	5/8
1/2	1/2	TF5715x8	.391	1.25	1.45	3/4
5/8	5/8	TF5715x10	.484	1.45	1.70	15/16
3/4	3/4	TF5715x12	.609	1.66	1.94	1-1/8
7/8	7/8	TF5715x14	.719	1.73	2.00	1-1/4
1	1	TF5715x16	.844	1.81	2.05	1-3/8
1-1/4	1-1/4	TF5715x20	1.078	2.06	2.25	1-3/4
1-1/2	1-1/2	TF5715x24	1.312	2.33	2.39	2

Cross

(Ref. SAE No. 070501)

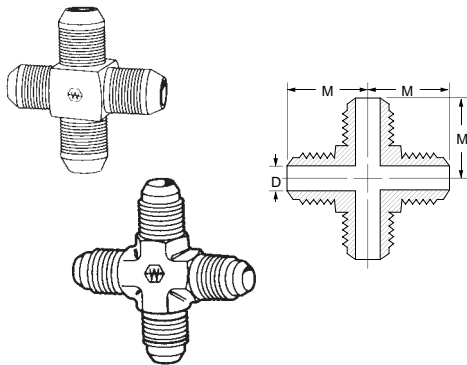

#Stainless Steel Construction

Tube O.D.	Catalog Number	D	M	Across Flats
1/4	TF5955x4	.172	.89	1/2
5/16	TF5955x5	.234	.95	9/16
3/8	TF5955x6	.297	1.06	5/8
1/2	TF5955x8	.391	1.25	13/16
5/8	TF5955x10	.484	1.45	15/16
3/4	TF5955x12	.609	1.66	1-1/8
7/8	TF5955x14	.718	1.73	1-1/4
1	TF5955x16	.844	1.81	1-3/8
1-1/4	TF5955x20	1.078	2.06	1-3/4
1-1/2	TF5955x24	1.312	2.33	2
1/4	5967x4#	.172	.89	7/16
3/8	5967x6#	.297	1.06	9/16
1/2	5967x8#	.391	1.25	3/4

Straight Thread O-Ring

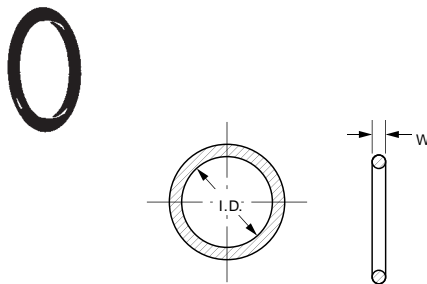

Material: Buna-N 90 Durometer
Temperature Range: -40°F to +250°F
 (-40°C to +121°C)
 Standard O-ring complies with SAE specification
 SAE J515 Type CH.

Tube O.D.	Catalog Number	W	I.D.
1/16	7629x1	.058	.185
1/8	7629x2	.064	.239
3/16	7629x3	.064	.301
1/4	7629x4	.072	.351
5/16	7629x5	.072	.414
3/8	7629x6	.078	.468
7/16	7629x7	.082	.530
1/2	7629x8	.087	.644
5/8	7629x10	.097	.755
3/4	7629x12	.116	.924
7/8	7629x14	.116	1.048
1	7629x16	.116	1.171
1-1/4	7629x20	.118	1.475
1-1/2	7629x24	.118	1.720
2	7629x32	.118	2.337

 Refer to safety information regarding tubing selection on page 1.

- **Typical Application:** Pressure hydraulic systems.
- **Sealing Method:** Performed by an elastometric O-ring.
- **NOTE:** For pressure, material and plating information, refer to appropriate steel fitting sections of this catalog:

Pipe - See page 141. **For-Seal** - See page 149. **JIC 37°** - See page 159.

Ermeto - See page 190. **Swivel Adapters** - See page 214.

Straight Thread O-Ring Hex Socket Plug (Ref. SAE No. 090109B)

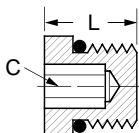

Replacement O-rings page 194.
NOTE: Parts furnished with zinc plate.

Port Size	Catalog Number	Hex C	L
1/8	7238x2	1/8	.40
3/16	7238x3	1/8	.40
1/4	7238x4	3/16	.47
5/16	7238x5	3/16	.47
3/8	7238x6	1/4	.50
1/2	7238x8	5/16	.58
5/8	7238x10	3/8	.65
3/4	7238x12	9/16	.77
7/8	7238x14	9/16	.77
1	7238x16	5/8	.77
1-1/4	7238x20	3/4	.78

Straight Thread O-Ring Hex Head Plug (Ref. SAE No. 090109A)

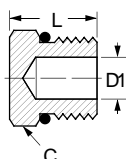

Replacement O-rings page 194.
NOTE: Parts furnished with zinc plate.

Port Size	Catalog Number	Hex C	L	D1 Opt.
1/8	7237x2	7/16	.60	.093
3/16	7237x3	1/2	.60	.125
1/4	7237x4	9/16	.67	.203
5/16	7237x5	5/8	.67	.234
3/8	7237x6	11/16	.73	.297
1/2	7237x8	7/8	.80	.422
5/8	7237x10	1	.93	.500
3/4	7237x12	1-1/4	1.09	.656
7/8	7237x14	1-3/8	1.09	.718
1	7237x16	1-1/2	1.12	.875
1-1/4	7237x20	1-7/8	1.20	1.093
1-1/2	7237x24	2-1/8	1.27	1.344
2	7237x32	2-3/4	1.42	1.815

Male Straight Thread/Female Straight Thread O-Ring Boss

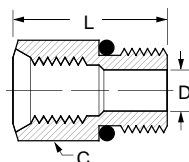

Replacement O-rings page 194.
NOTE: Parts furnished with zinc plate.

Male Port Size	Fem. Port Size	Catalog Number	Hex C	D	L
1/2	3/8	7033x8x6	7/8	.391	1.16
5/8	1/2	7033x10x8	1	.484	1.34
3/4	1/2	7033x12x8	1-1/4	.671	1.44
7/8	3/4	7033x14x12	1-3/8	.719	1.72
1	1/2	7033x16x8	1-1/2	.687	1.12
1	3/4	7033x16x12	1-1/2	.844	1.70
1-1/4	3/4	7033x20x12	1-7/8	.968	1.20
1-1/2	1-1/4	7033x24x20	2-1/8	1.312	1.75
2	1-1/2	7033x32x24	2-3/4	1.781	1.44

Straight Thread O-Ring Union

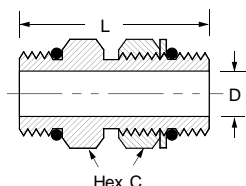
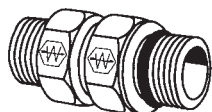

Replacement O-rings page 194.

Port Size	Catalog Number	Hex C	D	L
1/4	C5314x4x4	9/16	.172	1.37
3/8	C5314x6x6	11/16	.297	1.50
1/2	C5314x8x8	7/8	.391	1.56
5/8	C5314x10x10	1	.484	1.80
3/4	C5314x12x12	1-1/4	.609	2.33
1	C5314x16x16	1-1/2	.844	2.28
1-1/4	C5314x20x20	1-7/8	1.078	2.13
1-1/2	C5314x24x24	2-1/8	1.312	2.13
2	C5314x32x32	2-3/4	1.781	2.13

Straight Thread O-Ring

Steel Fittings

Male Straight Thread O-Ring to Male Pipe Adapter

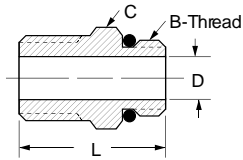
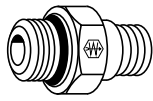

Replacement O-rings page 194.

Port Size	Male Pipe Thread	Catalog Number	Straight Thread B	Hex C	D	L
1/4	1/8	C3249x4x2	7/16-20	9/16	.172	1.05
3/8	1/4	C3249x6x4	9/16-18	11/16	.281	1.30
1/2	3/8	C3249x8x6	3/4-16	7/8	.391	1.36
1/2	1/2	C3249x8x8	3/4-16	7/8	.391	1.55
5/8	1/2	C3249x10x8	7/8-14	1	.484	1.69
3/4	3/4	C3249x12x12	1-1/16-12	1-1/4	.609	1.73
1	1	C3249x16x16	1-5/16-12	1-1/2	.844	2.06
1-1/4	1-1/4	C3249x20x20	1-5/8-12	1-7/8	1.078	2.17
1-1/2	1-1/2	C3249x24x24	1-7/8-12	2-1/8	1.312	2.26
2	2	C3249x32x32	2-1/2-12	2-3/4	1.781	2.47

Straight Thread O-Ring to Female Pipe Adapter

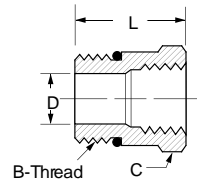
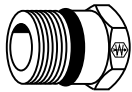

Replacement O-rings page 194.

Port Size	Female Pipe Thread	Catalog Number	Straight Thread B	Hex C	D	L
1/4	1/8	C3269x4x2	7/16-20	9/16	.172	.97
1/4	1/4	C3269x4x4	7/16-20	3/4	.172	1.16
5/16	1/8	C3269x5x2	1/2-20	5/8	.234	.94
3/8	1/4	C3269x6x4	9/16-18	3/4	.297	1.09
3/8	3/8	C3269x6x6	9/16-18	7/8	.281	1.30
3/8	1/2	C3269x6x8	9/16-18	1-1/8	.281	1.44
1/2	1/4	C3269x8x4	3/4-16	7/8	.421	1.06
1/2	3/8	C3269x8x6	3/4-16	7/8	.421	1.22
1/2	1/2	C3269x8x8	3/4-16	1-1/16	.421	1.50
5/8	1/4	C3269x10x4	7/8-14	1	.422	.81
5/8	3/8	C3269x10x6	7/8-14	1	.500	1.25
5/8	1/2	C3269x10x8	7/8-14	1-1/8	.500	1.50
5/8	3/4	C3269x10x12	7/8-14	1-3/8	.500	1.62
3/4	1/2	C3269x12x8	1-1/16-12	1-1/4	.688	1.34
3/4	3/4	C3269x12x12	1-1/16-12	1-3/8	.656	1.66
7/8	3/4	C3269x14x12	1-3/16-12	1-3/8	.718	1.63
1	1/2	C3269x16x8	1-5/16-12	1-1/2	.688	1.00
1	3/4	C3269x16x12	1-5/16-12	1-1/2	.876	1.50
1	1	C3269x16x16	1-5/16-12	1-5/8	.876	1.88
1-1/4	1	C3269x20x16	1-5/8-12	1-7/8	1.080	1.00
1-1/4	1-1/4	C3269x20x20	1-5/8-12	2	1.080	1.94
1-1/2	1-1/2	C3269x24x24	1-7/8-12	2-3/8	1.312	1.88
2	2	C3269x32x32	2-1/2-12	2-7/8	1.781	1.91

Straight Thread O-Ring Connector to For-Seal® (Ref. SAE No. 520120)

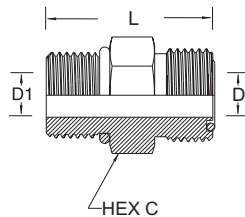
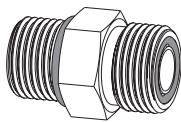

For replacement For-Seal® O-rings, see page 163.

Male Tube O.D.	Port Size	Catalog Number	Hex C	D	D1	L
1/4	1/4	4315x4	5/8	.172	.172	1.133
1/4	3/8	4315x4x6	11/16	.172	.172	1.202
3/8	1/4	4315x6x4	3/4	.264	.172	1.343
3/8	3/8	4315x6	3/4	.264	.264	1.252
3/8	1/2	4315x6x8	7/8	.378	.264	1.378
3/8	5/8	4315x6x10	1-1/16	.264	.484	1.530
1/2	3/8	4315x8x6	7/8	.378	.264	1.472
1/2	1/2	4315x8	7/8	.378	.378	1.441
1/2	5/8	4315x8x10	1	.378	.484	1.590
1/2	3/4	4315x8x12	1-1/4	.378	.609	1.748
5/8	5/8	4315x10	1-1/16	.484	.484	1.700
3/4	3/4	4315x12	1-1/4	.609	.609	1.918
3/4	1	4315x12x16	1-1/2	.609	.609	1.960
1	3/4	4315x16x12	1-1/2	.812	.609	2.138
1	1	4315x16	1-1/2	.811	.811	1.978
1	1-1/4	4315x16x20	1-7/8	.812	1.709	2.058
1-1/4	1	4315x20x16	1-3/4	1.024	.843	2.278
1-1/4	1-1/4	4315x20	1-7/8	1.024	1.024	2.058
1-1/2	1-1/2	4315x24	2-1/8	1.260	1.260	2.125

STEEL

Straight Thread O-Ring to For-Seal® Extended (Ref. SAE No. 520122)

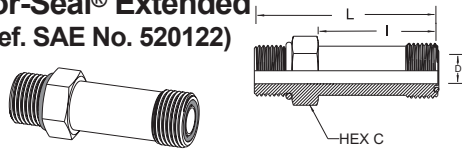

For replacement straight thread O-ring, see page 194.
Replacement For-Seal O-ring page 163.

Tube O.D.	Port Size	Catalog Number	Hex C	D	I	L
3/8	3/8	4316x6	3/4	.264	1.46	2.27
1/2	1/2	4316x8	7/8	.378	1.75	2.67
3/4	3/4	4316x12	1-1/4	.609	2.52	3.76
1	1	4316x16	1-1/2	.811	2.87	4.14
1-1/4	1-1/4	4316x20	1-7/8	1.024	3.41	4.76
1-1/2	1-1/2	4316x24	2-1/8	1.260	3.82	5.26

Female Straight Thread O-Ring to Male Pipe Adapter

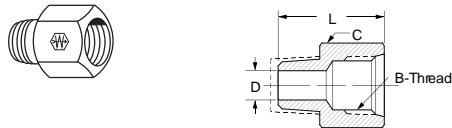

Fem. Port Size	Male Pipe Thread	Catalog Number	Straight Thread B	Hex C	D	L
3/8	3/8	C3239x6x6	9/16-18	13/16	.406	1.38
3/8	1/2	C3239x6x8	9/16-18	7/8	.500	1.61
1/2	3/8	C3239x8x6	3/4-16	1	.406	1.46
1/2	1/2	C3239x8x8	3/4-16	1	.562	1.69
5/8	1/2	C3239x10x8	7/8-14	1-1/4	.531	1.81

Straight Thread O-Ring Connector to Ermeto® Stainless Steel No. 7327x (Ref. SAE No. 080120)

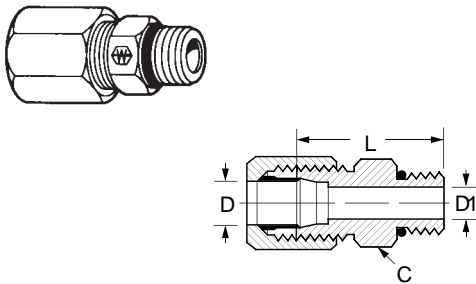

Replacement O-rings page 194.

Tube O.D.	Port Size	Catalog Number	Hex C	D	L	D1 Opt.
3/16	3/16	7315x3	1/2	.125	1.04	—
1/4	1/4	7315x4*	9/16	.203	1.13	—
1/4	5/16	7315x4x5*	5/8	.203	1.13	—
1/4	3/8	7315x4x6*	11/16	.203	1.19	.281
5/16	5/16	7315x5	5/8	.234	1.13	—
3/8	3/8	7315x6*	11/16	.281	1.21	—
3/8	1/2	7315x6x8	7/8	.281	1.29	.422
1/2	1/2	7315x8*	7/8	.422	1.38	—
1/2	5/8	7315x8x10	1	.422	1.51	.500
1/2	3/4	7315x8x12*	1-1/4	.422	1.67	.656
5/8	5/8	7315x10*	1	.500	1.57	—
3/4	3/4	7315x12*	1-1/4	.656	1.79	—
3/4	1	7315x12x16	1-1/2	.656	1.82	.876
7/8	7/8	7315x14	1-3/8	.718	1.79	—
1	3/4	7315x16x12	1-1/2	.875	1.82	.656
1	1	7315x16*	1-1/2	.875	1.82	—
1-1/4	1-1/4	7315x20	1-7/8	1.093	1.90	—
1-1/2	1-1/2	7315x24	2-1/8	1.344	1.97	—
2	2	7315x32	2-3/4	1.813	2.13	—

Male Straight Thread O-Ring to Female Pipe Swivel (Ref. SAE No. 140157)

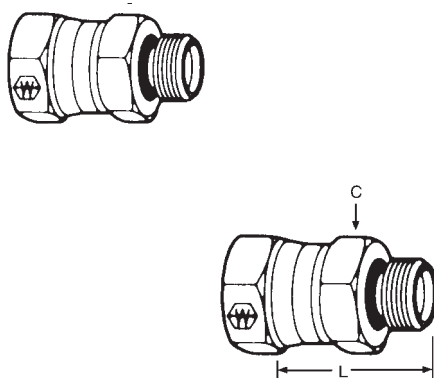

Replacement O-rings page 194.

Port Size	NPSM Swivel Nut	Catalog Number	Hex C	L
1/4	1/4-18	9315x4x4	9/16	.970
1/4	3/8-18	9315x4x6	5/8	1.060
5/16	1/4-18	9315x5x4	5/8	1.109
3/8	1/4-18	9315x6x4	11/16	1.171
3/8	3/8-18	9315x6x6	11/16	1.090
3/8	1/2-14	9315x6x8	13/16	1.210
1/2	1/4-18	9315x8x4	7/8	1.234
1/2	3/8-18	9315x8x6	7/8	1.200
1/2	1/2-14	9315x8x8	7/8	1.260
1/2	3/4-14	9315x8x12	1	1.406
5/8	3/8-18	9315x10x6	1	1.375
5/8	1/2-14	9315x10x8	1	1.400
5/8	3/4-14	9315x10x12	1	1.546
3/4	1/2-14	9315x12x8	1-1/4	1.540
3/4	3/4-14	9315x12x12	1-1/4	1.600
7/8	3/4-14	9315x14x12	1-3/8	1.703
1	3/4-14	9315x16x12	1-1/2	1.734
1	1-11-1/2	9315x16x16	1-1/2	1.710
1-1/4	1-11-1/2	9315x20x16	1-7/8	1.828
1-1/4	1-1/2-11-1/2	9315x20x20	1-7/8	1.890
1-1/2	1-1/2-11-1/2	9315x24x24	2-1/8	1.953
2	2-11-1/2	9315x32x32	2-3/4	2.156

* Available in stainless steel.

Straight Thread O-Ring

Steel
Fittings

**Straight Thread O-Ring
Connector to Male JIC 37°**
Stainless Steel No. **5327x**
(Ref. SAE No. 070120)
Example assembly No. **C35315x4**

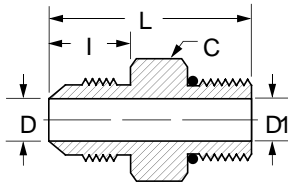
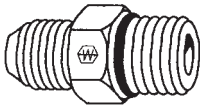

Replacement O-rings page 213.

Tube O.D.	Port Size	Catalog Number	Hex C	D	D1 Opt.	I	L
1/8	1/8	C5315x2•	7/16	.062	.062	.45	1.06
3/16	3/16	C5315x3	1/2	.125	.125	.48	1.10
1/4	1/4	C5315x4•	9/16	.172	.172	.55	1.23
1/4	5/16	C5315x4x5•	5/8	.172	.234	.55	1.23
1/4	3/8	C5315x4x6	11/16	.172	.172	.55	1.29
1/4	1/2	C5315x4x8	7/8	.172	.391	.55	1.38
5/16	1/4	C5315x5x4	9/16	.234	.172	.55	1.23
5/16	5/16	C5315x5	5/8	.234	.234	.55	1.23
5/16	3/8	C5315x5x6	11/16	.234	.297	.55	1.30
3/8	1/4	C5315x6x4	5/8	.297	.172	.56	1.33
3/8	5/16	C5315x6x5	5/8	.297	.234	.56	1.30
3/8	3/8	C5315x6•	11/16	.297	.297	.56	1.30
3/8	1/2	C5315x6x8•	7/8	.297	.391	.56	1.38
3/8	5/8	C5315x6x10	1	.297	.484	.56	1.50
1/2	3/8	C5315x8x6	13/16	.391	.297	.66	1.44
1/2	1/2	C5315x8•	7/8	.391	.391	.66	1.48
1/2	5/8	C5315x8x10•	1	.391	.484	.66	1.60
1/2	3/4	C5315x8x12•	1-1/4	.391	.609	.66	1.76
5/8	1/2	C5315x10x8	15/16	.484	.391	.76	1.67
5/8	5/8	C5315x10•	1	.484	.484	.76	1.70
5/8	3/4	C5315x10x12	1-1/4	.484	.609	.76	1.86
5/8	1	C5315x10x16	1-1/2	.484	.844	.76	1.89
3/4	1/2	C5315x12x8	1-1/8	.609	.391	.86	1.94
3/4	5/8	C5315x12x10	1-1/8	.609	.484	.86	1.88
3/4	3/4	C5315x12•	1-1/4	.609	.609	.86	1.97
3/4	7/8	C5315x12x14	1-3/8	.609	.718	.86	1.97
3/4	1	C5315x12x16	1-1/2	.609	.844	.86	1.99
3/4	1-1/4	C5315x12x20	1-7/8	.609	1.078	.86	2.08
7/8	7/8	C5315x14	1-3/8	.718	.718	.89	1.99
1	5/8	C5315x16x10	1-3/8	.844	.484	.91	1.95
1	3/4	C5315x16x12	1-3/8	.844	.609	.91	2.04
1	1	C5315x16•	1-1/2	.844	.844	.91	2.04
1	1-1/4	C5315x16x20	1-7/8	.844	1.078	.91	2.12
1-1/4	1	C5315x20x16	1-11/16	1.078	.844	.96	2.20
1-1/4	1-1/4	C5315x20	1-7/8	1.078	1.078	.96	2.17
1-1/4	1-1/2	C5315x20x24	2-1/8	1.078	1.312	.96	2.25
1-1/2	1-1/4	C5315x24x20	2	1.312	1.078	1.08	2.34
1-1/2	1-1/2	C5315x24	2-1/8	1.312	1.312	1.08	2.37
1-1/2	2	C5315x24x32	2-3/4	1.312	1.781	1.08	2.53
2	1-1/2	C5315x32x24	2-5/8	1.781	1.312	1.33	2.78
2	2	C5315x32	2-3/4	1.784	1.784	1.33	2.78

**Straight Thread O-Ring
Extended Connector to Male
JIC 37°**
(Ref. SAE No. 070122)
Example assembly No. **C35316x4**

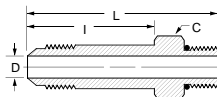
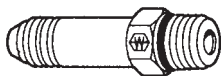

Replacement O-rings page 194.

Tube O.D.	Port Size	Catalog Number	Hex C	D	I	L
1/4	1/4	C5316x4	9/16	.172	1.39	2.08
3/8	3/8	C5316x6	11/16	.297	1.56	2.31
1/2	1/2	C5316x8	7/8	.391	1.88	2.70
5/8	5/8	C5316x10	1	.484	2.09	3.04
3/4	3/4	C5316x12	1-1/4	.609	2.50	3.61
1	1	C5316x16	1-1/2	.844	2.84	3.98
1-1/4	1-1/4	C5316x20	1-7/8	1.078	3.47	4.69

• Available in stainless steel.

STEEL

JIC 37° Female Swivel to Straight Thread O-Ring

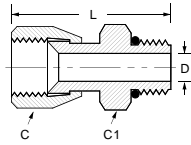
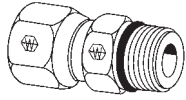

Replacement O-rings page 194.

Tube O.D.	Port Size	Catalog Number	Hex C	Hex C1	L	D
1/4	1/4	C5216x4x4	9/16	.56	.95	.172
1/4	3/8	C5216x4x6	9/16	.69	1.00	.172
3/8	3/8	C5216x6x6	11/16	.69	1.11	.297
3/8	1/2	C5216x6x8	11/16	.88	1.18	.297
1/2	3/8	C5216x8x6	7/8	3/4	1.71	.297
1/2	1/2	C5216x8x8	7/8	.88	1.17	.391
5/8	5/8	C5216x10x10	1	1.00	1.45	.484
3/4	3/4	C5216x12x12	1-1/4	1.25	1.61	.609
1	1	C5216x16x16	1-1/2	1.50	1.69	.844
1-1/4	1-1/4	C5216x20x20	2	1.88	1.82	1.078
1-1/2	1-1/2	C5216x24x24	2-1/8	2.12	1.88	1.312
2	2	C5216x32x32	2-3/4	2.75	2.01	1.781

45° Elbow - Male Straight Thread O-Ring to Male JIC 37° (Ref. SAE No. 070320) Example assembly No. C35365x4

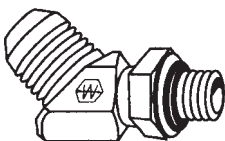
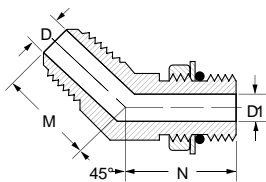
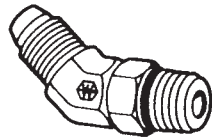

Replacement O-rings page 194.

*Special order only.

Tube O.D.	Port Size	Catalog Number	D	D1	M	N	Across Flats
1/4	1/4	C5365x4	.172	.172	.72	1.05	7/16
5/16	5/16	C5365x5*	.234	.234	.77	1.05	9/16
3/8	3/8	C5365x6	.297	.297	.83	1.14	9/16
1/2	1/2	C5365x8	.391	.391	.98	1.30	3/4
1/2	5/8	C5365x8x10	.391	.484	.99	1.52	7/8
5/8	5/8	C5365x10	.484	.484	1.11	1.52	7/8
3/4	5/8	C5365x12x10	.609	.484	1.28	1.57	1-1/16
3/4	3/4	C5365x12	.609	.609	1.28	1.73	1-1/16
1	1	C5365x16	.844	.844	1.47	1.86	1-5/16
1-1/4	1-1/4	C5365x20	1.078	1.078	1.59	1.91	1-5/8
1-1/2	1-1/2	C5365x24*	1.312	1.312	1.78	1.91	1-7/8
1/4	1/4	TF5365x4	.172	.172	.72	1.05	1/2
5/16	5/16	TF5365x5	.234	.234	.77	1.05	9/16
3/8	3/8	TF5365x6	.297	.297	.83	1.14	5/8
3/8	1/2	TF5365x6x8	.297	.391	.87	1.30	13/16
1/2	3/8	TF5365x8x6	.391	.297	.98	1.17	13/16
1/2	1/2	TF5365x8	.391	.391	.98	1.30	13/16
1/2	5/8	TF5365x8x10	.391	.484	.99	1.52	15/16
5/8	1/2	TF5365x10x8	.484	.391	1.09	1.41	15/16
5/8	5/8	TF5365x10	.484	.484	1.09	1.52	15/16
3/4	5/8	TF5365x12x10	.609	.484	1.30	1.58	1-1/8
3/4	3/4	TF5365x12	.609	.609	1.28	1.73	1-1/8
3/4	1	TF5365x12x16	.609	.844	1.45	1.86	1-3/8
7/8	7/8	TF5365x14	.718	.718	1.39	1.80	1-1/4
1	3/4	TF5365x16x12	.844	.609	1.47	1.86	1-3/8
1	1	TF5365x16	.844	.844	1.47	1.86	1-3/8
1-1/4	1-1/4	TF5365x20	1.078	1.078	1.59	1.91	1-3/4
1-1/2	1-1/2	TF5365x24	1.312	1.312	1.78	1.91	2
2	2	TF5365x32	1.781	1.781	2.22	1.86	2-5/8

Straight Thread O-Ring

Steel Fittings

45° Elbow - For-Seal® to Straight Thread O-Ring (Ref. SAE No. 520320)

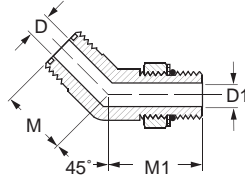
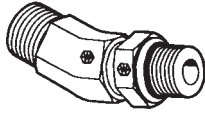

For replacement straight thread O-rings, see page 194.
For replacement For-Seal® o-rings, see page 163.

Tube O.D.	Port Size	Catalog Number	D	D1	M	M1	Across Flats
1/4	1/4	4365x4	.172	.172	.63	1.18	9/16
1/4	3/8	4365x4x6	.172	.264	.68	1.30	3/4
3/8	1/4	4365x6x4	.264	.172	.74	1.22	3/4
3/8	3/8	4365x6	.264	.264	.74	1.30	3/4
3/8	1/2	4365x6x8	.264	.390	.74	1.43	3/4
1/2	3/8	4365x8x6	.378	.264	.80	1.27	3/4
1/2	1/2	4365x8	.378	.390	.80	1.43	3/4
1/2	5/8	4365x8x10	.378	.484	.82	1.76	1-1/16
1/2	3/4	4365x8x12	.378	.609	.87	1.97	1-3/16
5/8	1/2	4365x10x8	.484	.390	.92	1.59	1-1/16
5/8	5/8	4365x10	.484	.484	.92	1.76	1-1/16
5/8	3/4	4365x10x12	.484	.609	.94	1.97	1-3/16
3/4	5/8	4365x12x10	.609	.484	1.02	1.81	1-3/16
3/4	3/4	4365x12	.609	.609	1.02	1.97	1-5/16
3/4	1	4365x12x16	.609	.811	1.16	2.06	1-5/16
1	3/4	4365x16x12	.811	.609	1.12	2.03	1-7/16
1	1	4365x16	.812	.811	1.18	2.06	1-1/2
1	1-1/4	4365x16x20	.811	1.081	1.26	1.11	1-5/8
1-1/4	1-1/4	4365x20	1.024	1.081	1.26	1.11	1-5/8
1-1/2	1-1/2	4365x24	1.260	1.312	1.45	1.11	1-7/8

45° Elbow - Male Straight Thread O-Ring to Female Pipe Swivel (Ref. SAE No. 140357)

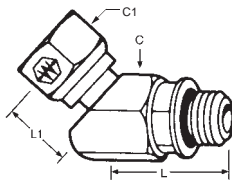
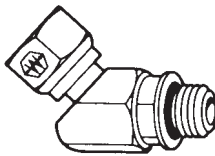

Replacement O-rings page 194.

Port Size	NPSM Swivel Nut	Catalog Number	Hex C	Hex C1	L	L1
1/4	1/4-18	9365x4x4	7/16	11/16	1.06	.66
1/4	3/8-18	9365x4x6	7/16	7/8	1.00	.75
3/8	3/8-18	9365x6x6	9/16	7/8	1.06	.70
3/8	1/2-14	9365x6x8	9/16	1	1.13	.82
1/2	3/8-18	9365x8x6	3/4	1	1.13	.88
1/2	1/2-14	9365x8x8	3/4	1	1.13	.82
5/8	1/2-14	9365x10x8	7/8	1	1.50	.78
3/4	3/4-14	9365x12x12	1-1/16	1-1/4	1.50	1.05
1	1-11-1/2	9365x16x16	1-5/16	1-1/2	1.62	1.06
1-1/4	1-1/4-11-1/2	9365x20x20	1-5/8	1-7/8	2.28	1.17
1-1/2	1-1/2-11-1/2	9365x24x24	1-7/8	2-1/8	2.61	1.34

90° Elbow - Straight Thread O-Ring to Male Pipe

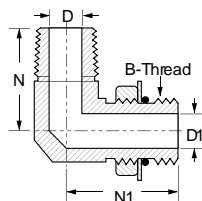
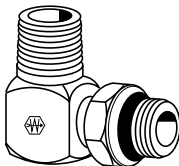

Replacement O-rings page 194.

Port Size	Male Pipe Thread	Catalog Number	Straight Thread B	D1	D	N	N1	Across Flats
1/4	1/8	TF3569x4	7/16-20	.172	.188	.78	1.03	1/2
5/16	1/8	TF3569x5	1/2-20	.234	.188	.78	1.09	9/16
3/8	1/4	TF3569x6	9/16-18	.297	.281	1.09	1.25	5/8
1/2	3/8	TF3569x8	3/4-16	.391	.406	1.22	1.45	13/16
5/8	1/2	TF3569x10	7/8-14	.484	.531	1.47	1.70	15/16
3/4	3/4	TF3569x12	1-1/16-12	.609	.719	1.59	1.94	1-1/8
7/8	3/4	TF3569x14	1-3/16-12	.719	.719	1.69	2.00	1-1/4
1	1	TF3569x16	1-5/16-12	.844	.938	1.97	2.05	1-3/8
1-1/4	1-1/4	TF3569x20	1-5/8-12	1.078	1.250	2.38	2.25	1-3/4
1-1/2	1-1/2	TF3569x24	1-7/8-12	1.312	1.500	2.64	2.39	2
2	2	TF3569x32	2-1/2-12	1.781	1.938	3.00	2.89	2-5/8

STEEL

**90° Elbow - Straight Thread
O-Ring to Male JIC 37°**
Stainless Steel **5527x**
(Ref. SAE No. 070220)
Example assembly No. **C35515x4**

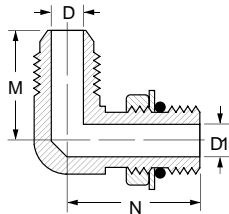
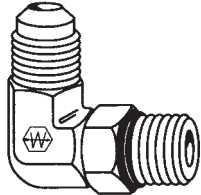

Replacement O-rings page 194.
*Special Order Only

**90° Elbow Long - Straight
Thread O-Ring to Male JIC 37°**

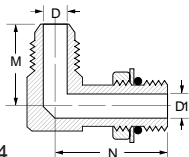
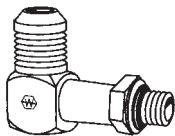

Replacement O-rings page 194.

Tube O.D.	Port Size	Catalog Number	D	D1	M	N	Across Flats
3/16	3/16	C5515x3	.125	.125	.83	.94	7/16
1/4	1/4	C5515x4	.172	.172	.89	1.03	7/16
5/16	5/16	C5515x5	.234	.234	.95	1.13	9/16
3/8	3/8	C5515x6	.297	.297	1.06	1.25	9/16
3/8	1/2	C5515x6x8	.297	.391	1.14	1.45	3/4
1/2	3/8	C5515x8x6	.391	.297	1.25	1.32	3/4
1/2	1/2	C5515x8	.391	.391	1.25	1.45	3/4
1/2	5/8	C5515x8x10	.391	.484	1.33	1.70	7/8
5/8	5/8	C5515x10	.484	.484	1.45	1.70	7/8
3/4	5/8	C5515x12x10	.609	.484	1.66	1.78	1-1/16
3/4	3/4	C5515x12	.609	.609	1.66	1.94	1-1/16
7/8	7/8	C5515x14	.718	.718	1.73	2.00	1-5/16
1	3/4	C5515x16x12	.844	.609	1.81	2.05	1-5/16
1	1	C5515x16	.844	.844	1.81	2.05	1-5/16
1-1/4	1-1/4	C5515x20	1.078	1.078	2.06	2.25	1-5/8
1-1/2	1-1/2	C5515x24*	1.312	1.312	2.33	2.39	1-7/8
1/4	1/4	TF5515x4	.172	.172	.89	1.03	1/2
1/4	5/16	TF5515x4x5	.172	.234	.95	1.12	5/8
1/4	3/8	TF5515x4x6	.172	.297	.95	1.25	5/8
5/16	1/4	TF5515x5x4	.234	.172	.98	1.06	9/16
5/16	5/16	TF5515x5	.234	.234	.95	1.09	9/16
5/16	3/8	TF5515x5x6	.234	.297	.98	1.25	5/8
3/8	1/4	TF5515x6x4	.297	.172	1.06	1.09	5/8
3/8	5/16	TF5515x6x5	.297	.234	1.06	1.12	5/8
3/8	3/8	TF5515x6	.297	.297	1.06	1.25	5/8
3/8	1/2	TF5515x6x8	.297	.391	1.16	1.45	13/16
3/8	5/8	TF5515x6x10	.297	.484	1.22	1.70	15/16
1/2	3/8	TF5515x8x6	.391	.297	1.25	1.34	13/16
1/2	1/2	TF5515x8	.391	.391	1.25	1.45	13/16
1/2	5/8	TF5515x8x10	.391	.484	1.31	1.70	15/16
1/2	3/4	TF5515x8x12	.391	.609	1.41	1.94	1-1/8
5/8	1/2	TF5515x10x8	.484	.391	1.45	1.52	15/16
5/8	5/8	TF5515x10	.484	.484	1.45	1.70	15/16
5/8	3/4	TF5515x10x12	.484	.609	1.55	1.94	1-1/8
3/4	1/2	TF5515x12x8	.609	.391	1.66	1.61	1-1/8
3/4	5/8	TF5515x12x10	.609	.484	1.66	1.80	1-1/8
3/4	3/4	TF5515x12	.609	.609	1.66	1.94	1-1/8
3/4	7/8	TF5515x12x14	.609	.718	1.72	2.00	1-1/4
3/4	1	TF5515x12x16	.609	.844	1.78	2.05	1-3/8
7/8	7/8	TF5515x14	.718	.718	1.73	2.00	1-5/16
1	3/4	TF5515x16x12	.844	.609	1.81	2.06	1-3/8
1	7/8	TF5515x16x14	.844	.718	1.81	2.06	1-3/8
1	1	TF5515x16	.844	.844	1.81	2.05	1-3/8
1	1-1/4	TF5515x16x20	.844	1.078	2.00	2.25	1-3/4
1-1/4	1	TF5515x20x16	1.078	.844	2.06	2.23	1-3/4
1-1/4	1-1/4	TF5515x20	1.078	1.078	2.06	2.25	1-3/4
1-1/2	1-1/4	TF5515x24x20	1.312	1.078	2.33	2.37	2
1-1/2	1-1/2	TF5515x24	1.312	1.312	2.33	2.39	2
2	2	TF5515x32	1.781	1.781	3.06	2.89	2-5/8

Tube O.D.	Port Size	Catalog Number	D	D1	M	N	Across Flats
3/8	3/8	TF5515x6L	.297	.297	1.06	1.66	5/8
1/2	1/2	TF5515x8L	.391	.391	1.25	1.81	13/16
5/8	5/8	TF5515x10L	.484	.484	1.45	2.16	15/16
3/4	3/4	TF5515x12L	.609	.609	1.66	2.47	1-1/8

• Available in stainless steel.

Straight Thread O-Ring

Steel Fittings

90° Elbow Extra Long - Male JIC 37° to Straight Thread O-Ring

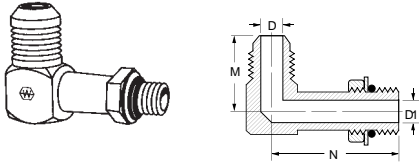

Replacement O-rings page 194.

Tube O.D.	Port Size	Catalog Number	D	D1	M	N	Across Flats
3/8	3/8	TF5515x6LL	.297	.297	1.06	2.08	5/8
1/2	1/2	TF5515x8LL	.391	.391	1.25	2.50	13/16
5/8	5/8	TF5515x10LL	.484	.484	1.45	3.25	15/16
3/4	3/4	TF5515x12LL	.609	.609	1.66	3.34	1-1/8

90° Elbow - For-Seal® Female Swivel to Male Straight Thread O-Ring (Ref. SAE No. 520281)

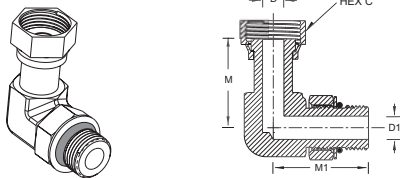

Tube O.D.	Port Size	Catalog Number	D	D1	M	M1	Hex C	Across Flats
1/4	1/4	4535x4	.165	.180	1.04	1.29	11/16	9/16
3/8	3/8	4535x6	.264	.300	1.15	1.45	13/16	3/4
1/2	1/2	4535x8	.358	.398	1.49	1.60	15/16	7/8
5/8	5/8	4535x10	.453	.498	1.62	1.97	1-1/8	1-1/16
3/4	3/4	4535x12	.547	.616	1.82	2.17	1-3/8	1-3/8
1	1	4535x16	.783	.852	2.10	2.35	1-5/8	1-5/8
1-1/4	1-1/4	4535x20	1.026	1.090	2.29	2.45	1-7/8	1-5/8
1-1/2	1-1/2	4535x24	1.262	1.326	2.41	2.59	2-1/4	1-7/8

90° Elbow - For-Seal® to Straight Thread O-Ring (Ref. SAE No. 520220)

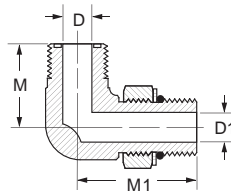
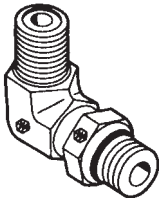

Tube O.D.	Port Size	Catalog Number	D	D1	M	M1	Across Flats
1/4	1/4	4515x4	.172	.172	.85	1.29	9/16
1/4	5/16	4515x4x5	.172	.234	.85	1.29	9/16
1/4	3/8	4515x4x6	.172	.264	.92	1.45	3/4
1/4	1/2	4515x4x8	.172	.390	.97	1.60	3/4
3/8	1/4	4515x6x4	.264	.172	.98	1.37	3/4
3/8	5/16	4515x6x5	.264	.234	.98	1.37	3/4
3/8	3/8	4515x6	.264	.264	.98	1.45	3/4
3/8	1/2	4515x6x8	.264	.390	1.04	1.60	3/4
3/8	5/8	4515x6x10	.264	.484	1.15	1.97	3/4
3/8	3/4	4515x6x12	.264	.609	1.25	2.17	1-3/16
1/2	3/8	4515x8x6	.378	.264	1.10	1.44	3/4
1/2	1/2	4515x8	.378	.390	1.10	1.60	3/4
1/2	5/8	4515x8x10	.378	.484	1.21	1.97	1-1/16
1/2	3/4	4515x8x12	.378	.484	1.32	2.17	1-1/16
5/8	1/2	4515x10x8	.484	.390	1.31	1.80	1-1/16
5/8	5/8	4515x10	.484	.484	1.31	1.97	1-1/16
5/8	3/4	4515x10x12	.484	.609	1.41	2.17	1-3/16
3/4	1/2	4515x12x8	.609	.390	1.47	1.84	1-3/16
3/4	5/8	4515x12x10	.609	.484	1.47	2.01	1-5/16
3/4	3/4	4515x12	.609	.609	1.47	2.17	1-5/16
3/4	1	4515x12x16	.609	.811	1.62	2.35	1-5/16
1	3/4	4515x16x12	.811	.609	1.64	2.32	1-5/8
1	7/8	4515x16x14	.811	.609	1.64	2.32	1-5/8
1	1	4515x16	.811	.811	1.64	2.35	1-5/8
1	1-1/4	4515x16x20	.811	1.081	1.76	2.45	1-5/8
1-1/4	1	4515x20x16	1.024	.811	1.76	2.42	1-5/8
1-1/4	1-1/4	4515x20	1.024	1.081	1.76	2.45	1-7/8
1-1/4	1-1/2	4515x20x24	1.024	1.312	1.92	2.59	1-7/8
1-1/2	1-1/4	4515x24x20	1.312	1.081	1.92	2.59	1-7/8
1-1/2	1-1/2	4515x24	1.312	1.312	1.92	2.59	1-7/8

Replacement Straight Thread O-rings page 194.
Replacement For-Seal O-rings page 163.

• Available in stainless steel.

STEEL

90° Elbow - Ermeto® to Straight Thread O-Ring
Stainless Steel No. 7527x
 (Ref. SAE No. 080220)

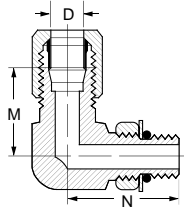
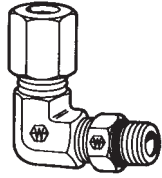

Replacement O-rings page 194.

Tube O.D.	Port Size	Catalog Number	D	M	N	Across Flats
1/4	1/4	7515x4	.203	.89	1.03	7/16
5/16	5/16	7515x5	.234	.96	1.13	9/16
3/8	3/8	7515x6	.281	1.05	1.25	9/16
1/2	1/2	7515x8	.422	1.25	1.45	3/4
5/8	5/8	7515x10	.500	1.42	1.70	7/8
3/4	3/4	7515x12	.656	1.58	1.94	1-1/16
1	1	7515x16	.875	1.73	2.05	1-5/16
1	3/4	7515x16x12	.875	1.73	2.05	1-5/16
1-1/4	1-1/4	7515x20	1.093	1.89	2.25	1-5/8

90° Elbow - Male Straight Thread O-Ring to Female Pipe Swivel
 (Ref. SAE No. 140257)

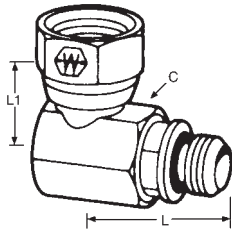

Replacement O-rings page 194.

Port Size	NPSM Swivel Nut	Catalog Number	Hex C	L	L1	Across Flats
1/4	1/4-18	9515x4x4	11/16	1.02	.75	11/16
1/4	3/8-18	9515x4x6	7/8	1.10	.90	7/8
3/8	1/4-18	9515x6x4	11/16	1.19	.78	11/16
3/8	3/8-18	9515x6x6	7/8	1.17	.90	7/8
3/8	1/2-14	9515x6x8	1	1.25	1.02	1
1/2	3/8-18	9515x8x6	1	1.36	1.00	1
1/2	1/2-14	9515x8x8	1	1.36	1.02	1
1/2	3/4-14	9515x8x12	1-1/4	1.66	1.25	1-1/4
5/8	3/8-18	9515x10x6	1	1.64	1.00	1
5/8	1/2-14	9515x10x8	1	1.50	1.02	1
5/8	3/4-14	9515x10x12	1-1/4	1.78	1.25	1-1/4
3/4	1/2-14	9515x12x8	1-1/4	1.92	1.12	1-1/4
3/4	3/4-14	9515x12x12	1-1/4	1.79	1.20	1-1/4
7/8	3/4-14	9515x14x12	1-1/4	1.92	1.25	1-1/4
1	3/4-14	9515x16x12	1-1/2	2.09	1.38	1-1/2
1	1-11-1/2	9515x16x16	1-1/2	2.09	1.39	1-1/2
1-1/4	3/4-14	9515x20x12	1-7/8	2.48	1.56	1-7/8
1-1/4	1-1/4-11-1/2	9515x20x20	1-7/8	2.48	1.66	1-7/8
1-1/2	1-1/2-11-1/2	9515x24x24	2-1/8	2.61	1.73	2-1/8
2	2-11-1/2	9515x32x32	2-5/8	3.25	2.31	2-5/8

90° Elbow - Straight Thread O-Ring to Female Pipe

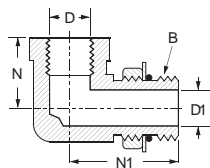

Replacement O-rings page 194.

Port Size	Fem. Pipe Thread	Catalog Number	Straight Thread B	D	D1	N	N1	Across Flats
1/2	3/8	C3459x8	3/4-16	.562	.422	.63	1.47	7/8
5/8	1/2	C3459x10	7/8-14	.687	.500	.75	1.81	1-1/16
3/4	3/4	C3459x12	1-1/16-12	.906	.656	.81	2.00	1-5/16
1	1	C3459x16	1-5/16-12	1.125	.876	1.00	2.25	1-5/8
1/4	1/8	TF3459x4	7/16-20	.332	.172	.66	1.09	5/8
5/16	1/8	TF3459x5	1/2-20	.332	.234	.66	1.13	5/8
3/8	1/4	TF3459x6	9/16-18	.437	.297	.88	1.31	3/4
1/2	3/8	TF3459x8	3/4-16	.562	.391	1.02	1.49	7/8
5/8	1/2	TF3459x10	7/8-14	.687	.484	1.23	1.80	1-1/8
3/4	3/4	TF3459x12	1-1/16-12	.906	.609	1.36	2.06	1-3/8
7/8	3/4	TF3459x14	1-3/16-12	.906	.719	1.42	2.06	1-3/8
1	1	TF3459x16	1-5/16-12	1.125	.844	1.62	2.17	1-5/8
1-1/4	1-1/4	TF3459x20	1-5/8-12	1.468	1.078	1.70	2.38	2
1-1/2	1-1/2	TF3459x24	1-7/8-12	1.703	1.312	2.08	2.58	2-3/8
2	2	TF3459x32	2-1/2-12	2.180	1.781	2.39	3.02	2-7/8

Straight Thread O-Ring

Steel Fittings

90° Elbow Long - Straight Thread O-Ring to Female Pipe

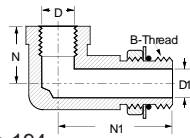
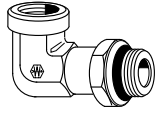

Replacement O-rings page 194.

Port Size	Fem. Pipe Thread	Catalog Number	Straight Thread B	D	D1	N	N1	Across Flats
1/2	3/8	C3469x8	3/4-16	.562	.422	.63	2.94	7/8
5/8	1/2	C3469x10	7/8-14	.687	.500	.75	3.56	1-1/16
3/4	3/4	C3469x12	1-1/16-12	.906	.656	.81	4.13	1-5/16
1	1	C3469x16	1-5/16-12	1.125	.876	1.00	4.63	1-5/8

Male JIC 37° to Straight Thread O-Ring Run Tee

(Ref. SAE No. 070428)

Example assembly No. C35716x4

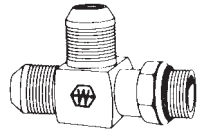
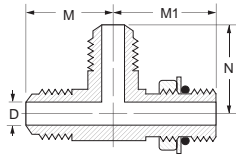
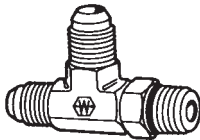

Replacement O-rings page 194.

Tube O.D.	Port Size	Catalog Number	D	M	N	M1	Across Flats
1/4	1/4	C5716x4	.172	.89	.89	1.03	7/16
5/16	5/16	C5716x5	.234	.95	.95	1.09	9/16
3/8	3/8	C5716x6	.297	1.06	1.06	1.25	9/16
1/2	1/2	C5716x8	.391	1.25	1.25	1.45	3/4
5/8	5/8	C5716x10	.484	1.45	1.45	1.70	7/8
3/4	3/4	C5716x12	.609	1.66	1.66	1.94	1-1/16
1	1	C5716x16	.844	1.81	1.81	2.05	1-5/16
1-1/4	1-1/4	C5716x20	1.078	2.06	2.06	2.25	1-5/8
1/4	1/4	TF5716x4	.172	.89	.89	1.03	1/2
5/16	5/16	TF5716x5	.234	.95	.95	1.09	9/16
3/8	3/8	TF5716x6	.297	1.06	1.06	1.25	5/8
1/2	1/2	TF5716x8	.391	1.25	1.25	1.45	13/16
5/8	5/8	TF5716x10	.484	1.45	1.45	1.70	15/16
3/4	3/4	TF5716x12	.609	1.66	1.66	1.94	1-1/8
7/8	7/8	TF5716x14	.718	1.73	1.73	2.00	1-1/4
1	1	TF5716x16	.844	1.81	1.81	2.05	1-3/8
1-1/4	1-1/4	TF5716x20	1.078	2.06	2.06	2.25	1-3/4
1-1/2	1-1/2	TF5716x24	1.312	2.33	2.33	2.39	2

Male JIC 37° to straight Thread O-Ring Branch Tee

(Ref. SAE No. 070429)

Example assembly No. C35715x4

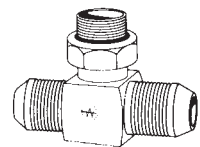
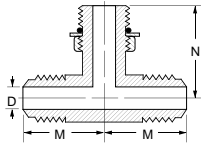
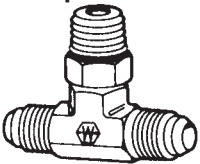

Replacement O-rings page 194.

*Special order only.

Tube O.D.	Port Size	Catalog Number	D	M	N	Across Flats
1/4	1/4	C5715x4	.172	.89	1.03	7/16
5/16	5/16	C5715x5*	.234	.95	1.09	9/16
3/8	3/8	C5715x6	.297	1.06	1.25	9/16
1/2	1/2	C5715x8	.391	1.25	1.45	3/4
5/8	5/8	C5715x10	.484	1.45	1.70	7/8
3/4	3/4	C5715x12	.609	1.66	1.94	1-1/16
1	1	C5715x16	.844	1.81	2.05	1-5/16
1/4	1/4	TF5715x4	.172	.89	1.03	7/16
5/16	5/16	TF5715x5	.234	.95	1.09	9/16
3/8	3/8	TF5715x6	.297	1.06	1.25	5/8
1/2	1/2	TF5715x8	.391	1.25	1.45	3/4
5/8	5/8	TF5715x10	.484	1.45	1.70	15/16
3/4	3/4	TF5715x12	.609	1.66	1.94	1-1/8
7/8	7/8	TF5715x14	.719	1.73	2.00	1-1/4
1	1	TF5715x16	.844	1.81	2.05	1-3/8
1-1/4	1-1/4	TF5715x20	1.078	2.06	2.25	1-3/4
1-1/2	1-1/2	TF5715x24	1.312	2.33	2.39	2

Ermeto® Straight Thread O-Ring Run Tee

(Stainless Steel No. 7728x)

(Ref. SAE No. 080428)

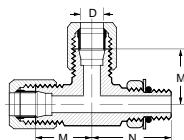
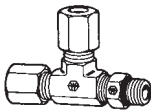

Replacement O-rings page 194.

Tube O.D.	Port Size	Catalog Number	D	M	N	Across Flats
1/4	1/4	7716x4*	.203	.89	1.03	7/16
3/8	3/8	7716x6*	.281	1.05	1.25	9/16
1/2	1/2	7716x8*	.422	1.25	1.45	3/4

* Available in stainless steel.

STEEL

Ermeto® Straight Thread O-Ring Branch Tee

Stainless Steel No. **7727x**
(Ref. SAE No. 080429)

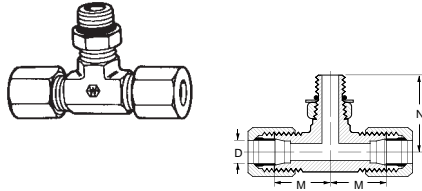

Replacement O-rings see below.

Tube O.D.	Port Size	Catalog Number	D	M	N	Across Flats
1/4	1/4	7715x4	.203	.89	1.03	7/16
3/8	3/8	7715x6	.281	1.05	1.25	9/16
1/2	1/2	7715x8	.422	1.25	1.45	3/4

For-Seal® to Straight Thread O-Ring Branch Tee

(Ref. SAE No. 520429)

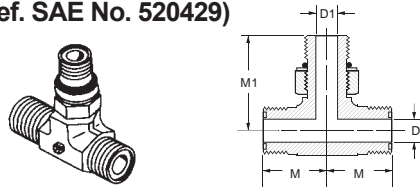

For replacement straight thread O-ring, see below.
For replacement FOR-SEAL® O-ring, see page 163.

Tube O.D.	Port Size	Catalog Number	D	D1	M	M1	Across Flats
1/4	1/4	4715x4	.172	.172	.85	1.29	9/16
3/8	3/8	4715x6	.264	.264	.98	1.45	3/4
3/8	1/2	4715x6x8	.264	.391	1.04	1.60	3/4
1/2	1/2	4715x8	.378	.390	1.10	1.60	3/4
5/8	5/8	4715x10	.484	.484	1.31	1.97	1-1/16
3/4	3/4	4715x12	.609	.609	1.47	2.17	1-3/16
1	1	4715x16	.811	.811	1.64	2.35	1-1/16

For-Seal® to Straight Thread Run Tee

(Ref. SAE No. 520428)

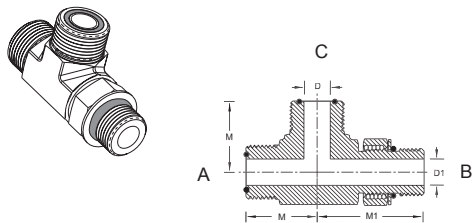

For replacement straight thread O-ring, see below.
For replacement FOR-SEAL® O-ring, see page 163.

Tube O.D. A	Tube O.D. B	Port Size C	Catalog Number	D	D1	M	M1	Across Flats
1/4	1/4	1/4	4716x4	.172	.172	.85	1.29	9/16
1/4	3/8	1/4	4716x4x4x6	.172	.264	1.39	1.45	3/4
3/8	3/8	3/8	4716x6	.264	.264	.98	1.45	3/4
1/2	1/2	1/2	4716x8	.378	.391	1.10	1.60	7/8
5/8	5/8	5/8	4716x10	.484	.484	1.31	1.97	1-1/16
3/4	3/4	3/4	4716x12	.609	.609	1.47	2.17	1-3/16
3/4	1	3/4	4716x12x12x16	.609	.812	1.62	2.32	1-7/16
3/4	3/4	1	4716x12x16x12	.609	.812	1.62	2.35	1-7/16
1	3/4	1	4716x16x16x12	.812	.609	1.64	2.35	1-7/16
1	1	1	4716x16	.812	.812	1.64	2.35	1-7/16
1-1/4	1-1/4	1-1/4	4716x20	1.046	1.046	1.76	2.45	1-7/8
1-1/2	1-1/2	1-1/2	4716x24	1.313	1.313	1.92	2.59	1-7/8

Straight Thread O-Ring

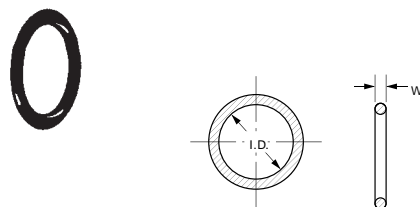

Material: Buna-N, 90 Durometer
Temperature Range: -40°F to +250°F
(-40°C to +121°C)
Standard O-ring complies with SAE specification J515 Type CH.

Port Size	Catalog Number	W	I.D.
1/16	7629x1	.058 ± .003	.185 ± .005
1/8	7629x2	.064 ± .003	.239 ± .005
3/16	7629x3	.064 ± .003	.301 ± .005
1/4	7629x4	.072 ± .003	.351 ± .005
5/16	7629x5	.072 ± .003	.414 ± .005
3/8	7629x6	.078 ± .003	.468 ± .005
7/16	7629x7	.082 ± .003	.530 ± .005
1/2	7629x8	.087 ± .003	.644 ± .005
5/8	7629x10	.097 ± .003	.755 ± .005
3/4	7629x12	.116 ± .004	.924 ± .006
7/8	7629x14	.116 ± .004	1.048 ± .006
1	7629x16	.116 ± .004	1.171 ± .006
1-1/4	7629x20	.118 ± .004	1.475 ± .010
1-1/2	7629x24	.118 ± .004	1.720 ± .010
2	7629x32	.118 ± .004	2.337 ± .010

• Available in stainless steel.

⚠ Refer to safety information regarding tubing selection on page 1.

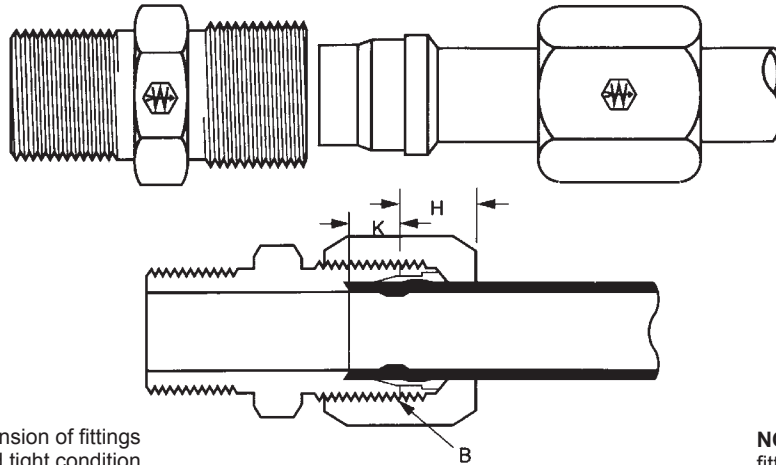

NOTE: "H" is dimension of fittings assembled to hand tight condition.

NOTE: Illustration shows fitting fully assembled.

Tube O.D.	1/8	3/16	1/4	5/16	3/8	1/2	5/8	3/4	7/8	1	1-1/4	1-1/2	2
Thread Size-B	5/16-24	3/8-24	7/16-20	1/2-20	9/16-18	3/4-16	7/8-14	1-1/16-12	1-3/16-12	1-5/16-12	1-5/8-12	1-7/8-12	2-1/2-12
Seat Depth-K	.19	.24	.24	.26	.26	.31	.36	.36	.36	.42	.42	.49	.49
H (Ref.)	.31	.30	.39	.41	.47	.48	.53	.55	.53	.63	.56	.61	.64

• **Typical Application**

Hydraulic, instrumentation and chemical processing systems. Highly recommended for high pressure applications.

• **Pressure**

Operating pressure up to 10,000 psi depending on tube and fitting size. See steel fittings recommendations, pages 199.

• **Vibration**

Excellent resistance.

• **Temperature Range**

-65°F to +400°F (-53°C to +204°C) at maximum operating pressures. Has been used at 800°F and 1000 psi to 4000 psi depending on tube size. Stainless steel has been used at +1000°F and 2000 psi.

• **Material**

Carbon Steel - AISI/SAE 12L14
Plating - Weathercote®
Stainless Steel - Bodies and nuts: type 316. Sleeves: 17-4PH.

• **Used With**

Aluminum, hard or half copper, steel, stainless steel, monel, titanium and extra heavy wall tubing that cannot be flared. See page 28-32 for material compatibility.

• **Advantages**

An excellent high pressure fitting - NO TUBE FLARING. Used with extra heavy wall tubing. Broad selection of sizes and styles.

• **Conformance**

Meets specifications and standards of ASA, ASME and SAE.

• **How to Order**

For complete assembly (body, nut and sleeve) order individually by catalog number. Example: 7205x4. To order body only (less nut and sleeve), prefix the catalog number with the letter "B". Example: B7205x4. Nuts and sleeves can be ordered separately by catalog number.

• **NOTE**

Refer to current price list for availability of cataloged items. Quotations and delivery of non-stock items supplied on request. Configurations and dimensions subject to change without notice. Additional information can be found in SAE J514.

• **Assembly Instructions**

See page 196.

• **Label Set:** FS-1600 (adhesive)

⚠ Refer to safety information regarding tubing selection on page 1.

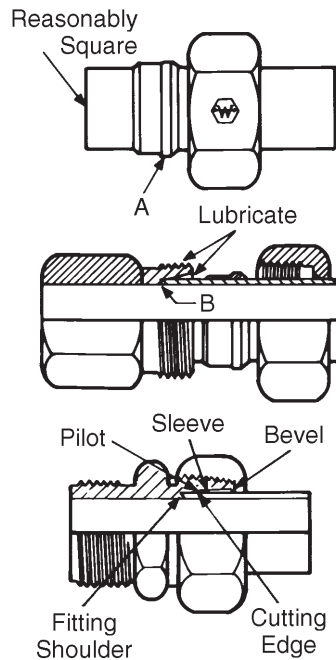

PRESETTING OPERATION

Preset with Preset Tool: (Preset tools are listed on page 222.)

1. **CAUTION:** All stainless steel sleeves should be preset in tool prior to installation.
2. Slide nut and then sleeve on tube. Shoulder of sleeve "A" must be toward nut.
3. Insert tube into presetting tool. Be sure that tube is bottomed on fitting tube stop at point "B". Lubricate threads, seat of fitting and shoulder of sleeve with good grade of lubricant.
4. Turn nut slowly with wrench while turning tube with other hand. When the sleeve grips the tube, that is, when the tube can no longer be turned by hand – **STOP** – and note the position of the wrench. This is the "Ring Grip" point.
5. Tighten nut an additional number of turns past the ring grip point per tube size and wall thickness as shown in Table 1, page 197.
6. Disassemble from preset tool.

Preset in Fitting Body:

1. Follow same procedure as when presetting with preset tool. Once the fitting nut has been turned the proper number of turns past ring grip, the fitting assembly is complete and ready for use.

NOTE: Only Carbon Steel Sleeves can be preset directly into the fitting body. Due to possible thread galling, the use of presetting tools is required when stainless steel fittings are to be assembled.

FITTING INSTALLATION

1. After sleeve and nut have been preset on the tubing and checked as described, the assembly is ready for installation into the Ermeto® fitting seat.
2. Lubricate threads, seat of fitting and shoulder of sleeve with a good grade of lubricant compatible with system fluid.
3. Insert tube assembly into fitting and tighten nut until sharp rise in torque is felt.
4. Starting at the position of sharp torque rise, tighten nut 1/4 turn to complete assembly.

When the assembly procedure for Ermeto fittings is followed correctly, these points will be evident:

1. Cutting edge of sleeve will be imbedded in tubing to its full depth.
2. Pilot edge of sleeve should be close to or touching O.D. of tubing.
3. Distance between end of tube and leading or pilot edge of sleeve will be at least 1/8".
4. Metal will be piled ahead of cutting edge of sleeve under pilot.
5. Contact area of sleeve will show evidence of being in perfect contact with tapered seat of fitting.
6. Sleeve will show evidence of being bowed within its elastic limits.
7. Back of sleeve will be in contact with tube.

NOTE: Performance of fitting will not be affected if sleeve rotates on tube after disassembly.

FOR RE-INSTALLATION OF FITTING AFTER DISASSEMBLING

1. Insert tube assembly into fitting, tighten nut until a sharp rise in torque is felt.
2. Starting at the position of sharp torque rise, tighten nut 1/4 turn to complete the reinstallation.

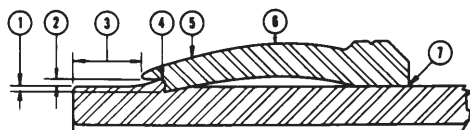

 Refer to safety information regarding tubing selection on page 1.

7000 SERIES

TABLE 1: Number of Additional Turns from “Ring Grip” for Hand Presetting Operation-Ermeto® Sleeve

Tube Size	Tube Material **	Tube Wall Thickness									
		.018	.022	.028	.035	.049	.065	.083	.095	.109	.120
2	C 1010	1-1/6	1-1/6	1-1/6	1-1/6						
	MIL T 8504	1-1/6	1-1/6	1-1/6	1-1/6						
3	C 1010	1-1/6	1-1/6	1-1/6	1						
	MIL T 8504	1-1/6	1-1/6	1-1/6	1						
4	C 1010			1-1/6	1-1/6	1-1/6	1				
	MIL T 8504			1-1/6	1	1	5/6				
5	C 1010			1-1/6	1-1/6	1-1/6	1				
	MIL T 8504			1-1/6	1-1/6	1	1				
6	C 1010				1-1/6	1-1/6	1	1			
	MIL T 8504				1-1/6	1	5/6	5/6			
8	C 1010				1-1/6	1-1/6	1	1	1		
	MIL T 8504				1-1/6	1	5/6	5/6	5/6		
10	C 1010					1-1/6	1	5/6	5/6	5/6	5/6
	MIL T 8504					1-1/6	1	5/6	5/6	5/6	5/6
12	C 1010					1	1	5/6	5/6	5/6	
	MIL T 8504					1-1/6	1	5/6	5/6	5/6	
16	C 1010					1-1/6	1-1/6	5/6	5/6	5/6	
	MIL T 8504					1-1/6	1-1/6	5/6	5/6	5/6	
20	C 1010					1-1/6	1	1	1	5/6	5/6
	MIL T 8504					1	1	1	1	5/6	5/6
24	C 1010								1	1	1
	MIL T 8504								1	1	1
32	C 1010								1	1	1
	MIL T 8504								1	1	1

** C 1010 – Carbon Steel Tubing

** MIL T 8504 – Annealed Stainless Steel

STEEL

⚠ Refer to safety information regarding tubing selection on page 1.

Ermeto® Fittings (7000 Series) are especially designed for making leak-proof tube connections. This fitting will effectively withstand high pressure, severe vibration and extreme temperature. No special tools are needed for assembly. Simply cut tube square, preset sleeve on tubing and assemble.

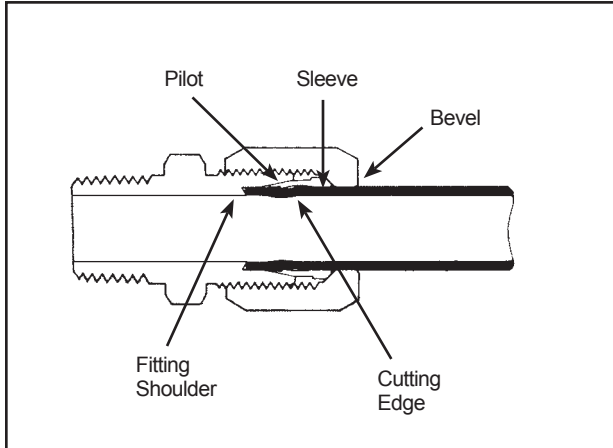

ERMETO® DESIGN PRINCIPLE PROVIDES POSITIVE SEAL

1. In presetting, as the nut is tightened it forces the sleeve forward into the body taper. See page 196 for preset instructions.
2. Pilot of sleeve contracts, forcing the cutting edge of sleeve to shear a groove into outer surface of the tube, making a tight joint between fitting and tube.
3. In assembling the preset sleeve and tube into the fitting body, the nut presses on the bevel at rear of sleeve causing it to clamp tightly to the tube. Resistance to vibration is concentrated at this point rather than at the sleeve cut.
4. When fully tightened, the case hardened sleeve is bowed slightly at the midsection and acts as a spring. This spring action of the sleeve maintains a constant tension between the body and the nut, and thus prevents the nut from loosening.
5. After the first assembly, the sleeve is permanently attached to the tube. Disassembly and reassembly of the fitting can be made without loss of strength or sealing qualities.

“7000” SERIES FITTINGS

Specifically designed to meet all SAE approved standards for hydraulic flareless tube fittings. Available in a complete range of standard body styles. In addition, the “7000” Series includes all body styles for SAE straight thread O-ring boss mounting. Complete size range to 2”.

CARBON STEEL “7000” SERIES

Weatherhead Ermeto® Fittings have the exclusive “Weathercote” finish, which fully resists the effects of non-flammable hydraulic fluids.

STAINLESS STEEL “7000” SERIES

Fittings also available in a complete range of body styles and sizes.

Standard stainless steel assemblies may be ordered by quoting the stainless steel part numbers appearing in this catalog. Standard stainless steel assemblies are composed of the following types of material:

BODY – Type 316 Stainless Steel

NUT – Type 316 Stainless Steel

SLEEVE – Type 17-4PH Stainless Steel

Any deviation from the standard assembly must be ordered as component parts. Example: If Type 316 bodies and 17-4PH sleeves are to be used, they can be ordered as follows:

B7217x8 Body only (Type 316 Stainless Steel)

7176x8 Sleeves (Type 17-4PH Stainless Steel)

7105x8 Nuts (Standard Carbon Steel)

In general, the “bite-action” of the sleeves in any given material varies as shown in the following table:

STAINLESS STEEL SLEEVES

Cat. No. 7176 sleeves are made from Armco 17-4PH pre-precipitation hardened stainless steel. When used on “fully-annealed” to 1/8 hard tubing in the 303 to 316 stainless range, they provide the typical seal.

“7000” Series Sleeve	SLEEVE MATERIAL	TUBING USED 303 to 316 Stainless and Cupro-Nickel	“BITE-ACTION”
7165	Heat Treated Carbon Steel (Standard Carbon)	Fully annealed to 1/8 hard	Excellent
7176	17-4PH Stainless (Standard Stainless)	Fully annealed	Excellent

When stainless steel tubing is used for strength and no corrosive conditions exist, use the 7165 sleeve for better performance.

HYDRAULIC PRESSURE DATA – ERMETO® FLARELESS FITTINGS

Ermeto® fittings have been used with success on many and varied applications far exceeding the conservative conditions presented below. Specifically:

- Temperatures up to 800°F, in carbon steel and 1000°F, in stainless steel have been handled without failure.*
- Burst pressures up to 32,000 psi with 1/4" tubing.
- Vibration conditions of 1/8" off-center amplitude with 12" overhang in 1/4" tubing have been withstood at rated operating pressure with 4-to-1 safety factors for over ten million cycles.

Obviously under extreme conditions of pressure, temperature and/or vibration, the safety factor is proportionately reduced.

The Ermeto® flareless fitting is the ultimate hydraulic fitting available today. Special performance conditions as outlined can be accommodated; however, it is recommended that your local Weatherhead representative be consulted for engineering assistance prior to finalizing design.

The values shown in the following table are pressure ratings of Ermeto® flareless fittings under various surge conditions. They apply and are recommended for conservative operating conditions. Consult tubing selection charts on pages 22 and 23.

Size No.	Size in Inches	Maximum Pressure† No Surges PSI	Maximum Pressure† With Surges to 50%	Maximum Pressure† With Surges of 50% to 100%	Maximum Pressure† With Surges up to 150%
2	1/8	10,000	6,500	5,000	4,000
3	3/16	9,000	6,000	4,500	3,600
4	1/4	8,000	5,250	4,000	3,200
5	5/16	8,000	5,250	4,000	3,200
6	3/8	7,500	5,000	3,750	3,000
8	1/2	7,000	4,500	3,500	2,700
10	5/8	5,000	3,250	2,500	2,000
12	3/4	5,000	3,250	2,500	2,000
14	7/8	3,750	2,500	1,800	1,500
16	1	3,600	2,400	1,800	1,400
20	1-1/4	3,200	2,100	1,600	1,275
24	1-1/2	3,000	2,000	1,500	1,200
32	2	2,750	1,800	1,350	1,100

† Pressures shown do not apply to pneumatic applications or stainless steel tubing installations.

* Zinc plating discolours at temperatures over 400°F and melts at 750°F.

Straight Thread O-Ring Thread Sizes

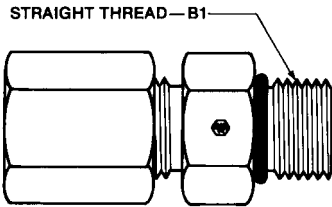

Port Size	Thread Size B1	Port Size	Thread Size B1
1/8	5/16-24	3/4	1-1/16-12
3/16	3/8-24	7/8	1-3/16-12
1/4	7/16-20	1	1-5/16-12
5/16	1/2-20	1-1/4	1-5/8-12
3/8	9/16-18	1-1/2	1-7/8-12
1/2	3/4-16	2	2-1/2-12
5/8	7/8-14		

7000 Series Reducer

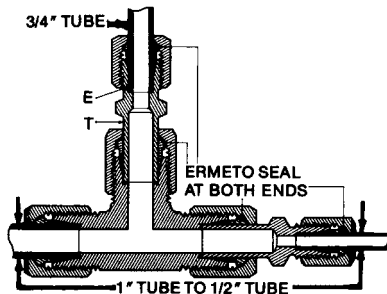

Enables You to Fabricate Special Fittings from Standard Parts

The Weatherhead reducer consists of body, nut and sleeve. It has one end (T) machined in the form of a tube with a flareless tube connection on the opposite end (E). A convenient hex wrench pad is provided to facilitate assembly.

1. Connect the tube end (T) of the reducer to the flareless fitting already assembled in the tubing system.
2. Connect the smaller O.D. tubing to end (E).

CAUTION: Be sure to hold reducer by the hex wrench pad while performing Step 2.

Our example of 7705x12x6x8 is made up by using reducers 7015x12x6 and 7015x12x8 with the standard 7705x12 tee.

Straight Thread O-Ring Fitting

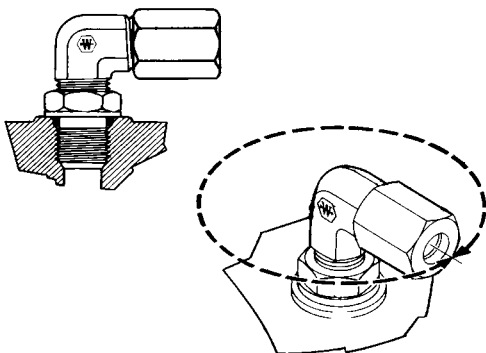



Adjustable Fittings

- Permit exact positioning of tees and elbows.
 - Provide a leakproof joint.
 - Eliminate distorted bosses from overtightening.
1. Lubricate O-ring by coating with a light oil or petrolatum and push back-up washer and O-ring to the extreme rear of the O-ring groove.
 2. Turn the lock nut down until it just contacts the back-up washer.
 3. Screw fitting by hand into straight thread boss until the back-up washer contacts the face of the boss.
 4. Position the fitting by backing out (counter-clockwise) up to one full turn. Hold fitting in desired position and tighten lock nut with a wrench.
 5. Assemble tube to fitting. Re-tighten lock nut.
- NOTE:** O-Rings, lock nuts and back-up washers are preassembled on all straight thread fittings.

Flareless – 7000 Series Ermeto®

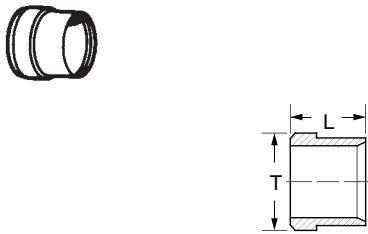
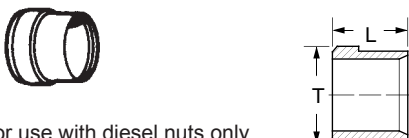
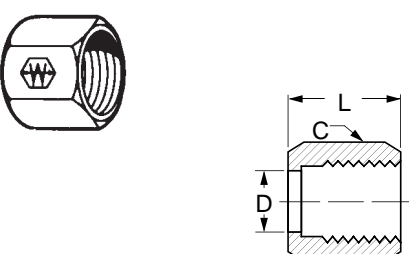
Steel Fittings

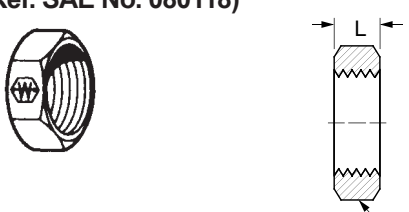
<p>Sleeve Stainless Steel No. 7176x (Ref. SAE No. 080115B)</p> 	<table border="1"> <thead> <tr> <th>Tube O.D.</th> <th>Catalog Number</th> <th>L</th> <th>Dia. T</th> </tr> </thead> <tbody> <tr><td>1/8</td><td>7165x2•</td><td>.28</td><td>.20</td></tr> <tr><td>3/16</td><td>7165x3•</td><td>.28</td><td>.31</td></tr> <tr><td>1/4</td><td>7165x4•</td><td>.34</td><td>.36</td></tr> <tr><td>5/16</td><td>7165x5•</td><td>.34</td><td>.42</td></tr> <tr><td>3/8</td><td>7165x6•</td><td>.38</td><td>.48</td></tr> <tr><td>1/2</td><td>7165x8•</td><td>.38</td><td>.63</td></tr> <tr><td>5/8</td><td>7165x10•</td><td>.42</td><td>.75</td></tr> <tr><td>3/4</td><td>7165x12•</td><td>.42</td><td>.88</td></tr> <tr><td>7/8</td><td>7165x14•</td><td>.42</td><td>1.00</td></tr> <tr><td>1</td><td>7165x16•</td><td>.42</td><td>1.13</td></tr> <tr><td>1-1/4</td><td>7165x20•</td><td>.42</td><td>1.41</td></tr> <tr><td>1-1/2</td><td>7165x24•</td><td>.42</td><td>1.66</td></tr> <tr><td>2</td><td>7165x32•</td><td>.45</td><td>2.19</td></tr> </tbody> </table>	Tube O.D.	Catalog Number	L	Dia. T	1/8	7165x2•	.28	.20	3/16	7165x3•	.28	.31	1/4	7165x4•	.34	.36	5/16	7165x5•	.34	.42	3/8	7165x6•	.38	.48	1/2	7165x8•	.38	.63	5/8	7165x10•	.42	.75	3/4	7165x12•	.42	.88	7/8	7165x14•	.42	1.00	1	7165x16•	.42	1.13	1-1/4	7165x20•	.42	1.41	1-1/2	7165x24•	.42	1.66	2	7165x32•	.45	2.19														
Tube O.D.	Catalog Number	L	Dia. T																																																																				
1/8	7165x2•	.28	.20																																																																				
3/16	7165x3•	.28	.31																																																																				
1/4	7165x4•	.34	.36																																																																				
5/16	7165x5•	.34	.42																																																																				
3/8	7165x6•	.38	.48																																																																				
1/2	7165x8•	.38	.63																																																																				
5/8	7165x10•	.42	.75																																																																				
3/4	7165x12•	.42	.88																																																																				
7/8	7165x14•	.42	1.00																																																																				
1	7165x16•	.42	1.13																																																																				
1-1/4	7165x20•	.42	1.41																																																																				
1-1/2	7165x24•	.42	1.66																																																																				
2	7165x32•	.45	2.19																																																																				
<p>Sleeve</p>  <p>For use with diesel nuts only.</p>	<table border="1"> <thead> <tr> <th>Tube O.D.</th> <th>Catalog Number</th> <th>L</th> <th>Dia. T</th> </tr> </thead> <tbody> <tr><td>1/4</td><td>8165x4</td><td>.34</td><td>.38</td></tr> <tr><td>5/16</td><td>8165x5</td><td>.34</td><td>.44</td></tr> <tr><td>3/8</td><td>8165x6</td><td>.38</td><td>.50</td></tr> </tbody> </table>	Tube O.D.	Catalog Number	L	Dia. T	1/4	8165x4	.34	.38	5/16	8165x5	.34	.44	3/8	8165x6	.38	.50																																																						
Tube O.D.	Catalog Number	L	Dia. T																																																																				
1/4	8165x4	.34	.38																																																																				
5/16	8165x5	.34	.44																																																																				
3/8	8165x6	.38	.50																																																																				
<p>Nut Stainless Steel No. 7117x (Ref. SAE No. 080110)</p> 	<table border="1"> <thead> <tr> <th>Tube O.D.</th> <th>Catalog Number</th> <th>Hex C</th> <th>L</th> <th>D Dia.</th> </tr> </thead> <tbody> <tr><td>1/8</td><td>7105x2•</td><td>3/8</td><td>.53</td><td>.132</td></tr> <tr><td>3/16</td><td>7105x3•</td><td>7/16</td><td>.61</td><td>.195</td></tr> <tr><td>1/4</td><td>7105x4•</td><td>9/16</td><td>.70</td><td>.257</td></tr> <tr><td>5/16</td><td>7105x5•</td><td>5/8</td><td>.72</td><td>.320</td></tr> <tr><td>3/8</td><td>7105x6•</td><td>11/16</td><td>.75</td><td>.382</td></tr> <tr><td>1/2</td><td>7105x8•</td><td>7/8</td><td>.84</td><td>.508</td></tr> <tr><td>5/8</td><td>7105x10•</td><td>1</td><td>.92</td><td>.634</td></tr> <tr><td>3/4</td><td>7105x12•</td><td>1-1/4</td><td>.97</td><td>.759</td></tr> <tr><td>7/8</td><td>7105x14•</td><td>1-3/8</td><td>1.00</td><td>.884</td></tr> <tr><td>1</td><td>7105x16•</td><td>1-1/2</td><td>1.05</td><td>1.009</td></tr> <tr><td>1-1/4</td><td>7105x20•</td><td>2</td><td>1.05</td><td>1.263</td></tr> <tr><td>1-1/2</td><td>7105x24•</td><td>2-1/4</td><td>1.03</td><td>1.513</td></tr> <tr><td>2</td><td>7105x32•</td><td>2-7/8</td><td>1.12</td><td>2.017</td></tr> </tbody> </table>	Tube O.D.	Catalog Number	Hex C	L	D Dia.	1/8	7105x2•	3/8	.53	.132	3/16	7105x3•	7/16	.61	.195	1/4	7105x4•	9/16	.70	.257	5/16	7105x5•	5/8	.72	.320	3/8	7105x6•	11/16	.75	.382	1/2	7105x8•	7/8	.84	.508	5/8	7105x10•	1	.92	.634	3/4	7105x12•	1-1/4	.97	.759	7/8	7105x14•	1-3/8	1.00	.884	1	7105x16•	1-1/2	1.05	1.009	1-1/4	7105x20•	2	1.05	1.263	1-1/2	7105x24•	2-1/4	1.03	1.513	2	7105x32•	2-7/8	1.12	2.017
Tube O.D.	Catalog Number	Hex C	L	D Dia.																																																																			
1/8	7105x2•	3/8	.53	.132																																																																			
3/16	7105x3•	7/16	.61	.195																																																																			
1/4	7105x4•	9/16	.70	.257																																																																			
5/16	7105x5•	5/8	.72	.320																																																																			
3/8	7105x6•	11/16	.75	.382																																																																			
1/2	7105x8•	7/8	.84	.508																																																																			
5/8	7105x10•	1	.92	.634																																																																			
3/4	7105x12•	1-1/4	.97	.759																																																																			
7/8	7105x14•	1-3/8	1.00	.884																																																																			
1	7105x16•	1-1/2	1.05	1.009																																																																			
1-1/4	7105x20•	2	1.05	1.263																																																																			
1-1/2	7105x24•	2-1/4	1.03	1.513																																																																			
2	7105x32•	2-7/8	1.12	2.017																																																																			
<p>Diesel Nut</p> 	<table border="1"> <thead> <tr> <th>Tube O.D.</th> <th>Thread Size</th> <th>Catalog Number</th> <th>Hex C</th> <th>L</th> </tr> </thead> <tbody> <tr><td>1/4</td><td>9/16-18</td><td>8112x4</td><td>3/4</td><td>.94</td></tr> <tr><td>5/16</td><td>5/8-18</td><td>8112x5</td><td>13/16</td><td>1.00</td></tr> <tr><td>3/8</td><td>3/4-16</td><td>8112x6</td><td>15/16</td><td>1.13</td></tr> </tbody> </table>	Tube O.D.	Thread Size	Catalog Number	Hex C	L	1/4	9/16-18	8112x4	3/4	.94	5/16	5/8-18	8112x5	13/16	1.00	3/8	3/4-16	8112x6	15/16	1.13																																																		
Tube O.D.	Thread Size	Catalog Number	Hex C	L																																																																			
1/4	9/16-18	8112x4	3/4	.94																																																																			
5/16	5/8-18	8112x5	13/16	1.00																																																																			
3/8	3/4-16	8112x6	15/16	1.13																																																																			
<p>Bulkhead Nut Stainless Steel No. 7936x (Ref. SAE No. 080118)</p> 	<table border="1"> <thead> <tr> <th>Tube O.D.</th> <th>Catalog Number</th> <th>Hex C</th> <th>L</th> </tr> </thead> <tbody> <tr><td>1/4</td><td>7924x4•</td><td>11/16</td><td>.28</td></tr> <tr><td>3/8</td><td>7924x6•</td><td>13/16</td><td>.27</td></tr> <tr><td>1/2</td><td>7924x8•</td><td>1</td><td>.31</td></tr> <tr><td>5/8</td><td>7924x10•</td><td>1-1/8</td><td>.36</td></tr> <tr><td>3/4</td><td>7924x12•</td><td>1-3/8</td><td>.41</td></tr> <tr><td>7/8</td><td>7924x14</td><td>1-1/2</td><td>.41</td></tr> <tr><td>1</td><td>7924x16•</td><td>1-5/8</td><td>.41</td></tr> <tr><td>1-1/4</td><td>7924x20</td><td>1-7/8</td><td>.41</td></tr> </tbody> </table>	Tube O.D.	Catalog Number	Hex C	L	1/4	7924x4•	11/16	.28	3/8	7924x6•	13/16	.27	1/2	7924x8•	1	.31	5/8	7924x10•	1-1/8	.36	3/4	7924x12•	1-3/8	.41	7/8	7924x14	1-1/2	.41	1	7924x16•	1-5/8	.41	1-1/4	7924x20	1-7/8	.41																																		
Tube O.D.	Catalog Number	Hex C	L																																																																				
1/4	7924x4•	11/16	.28																																																																				
3/8	7924x6•	13/16	.27																																																																				
1/2	7924x8•	1	.31																																																																				
5/8	7924x10•	1-1/8	.36																																																																				
3/4	7924x12•	1-3/8	.41																																																																				
7/8	7924x14	1-1/2	.41																																																																				
1	7924x16•	1-5/8	.41																																																																				
1-1/4	7924x20	1-7/8	.41																																																																				

• Available in stainless steel.

STEEL

Cap
Stainless Steel No. **7141x**

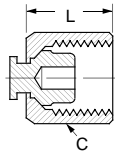
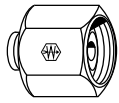

Tube O.D.	Catalog Number	Hex C	L
1/4	7129x4•	9/16	.70
3/8	7129x6•	11/16	.75
1/2	7129x8•	7/8	.84
5/8	7129x10•	1	.92
3/4	7129x12•	1-1/4	.97
1	7129x16•	1-1/2	1.05
1-1/4	7129x20	2	1.05

Plug
Stainless Steel No. **7241x**
(Ref. SAE No. 080109)

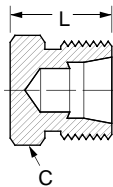

Tube O.D.	Catalog Number	Hex C	L
1/8	7229x2	7/16	.63
1/4	7229x4•	1/2	.71
5/16	7229x5	9/16	.71
3/8	7229x6•	5/8	.75
1/2	7229x8•	13/16	.85
5/8	7229x10	15/16	.97
3/4	7229x12•	1-1/8	1.10
1	7229x16	1-3/8	1.10

Reducer
Stainless Steel No. **7027x**
(Ref. SAE No. 080123)

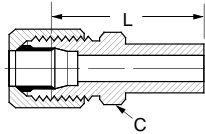
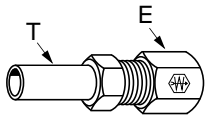

• 7028x16x8

Body Size T	Tube Size E	Catalog Number	Hex C	L
3/8	1/4	7015x6x4•	1/2	1.61
1/2	1/4	7015x8x4•	9/16	1.73
1/2	3/8	7015x8x6•	5/8	1.77
5/8	1/2	7015x10x8•	13/16	1.96
3/4	3/8	7015x12x6•	13/16	1.93
3/4	1/2	7015x12x8•	13/16	2.03
1	3/4	7015x16x12•	1-1/8	2.24
1-1/4	1	7015x20x16•	1-3/8	2.28

Small Hex Union
Stainless Steel No. **7317x**
(Ref. SAE No. 080101)

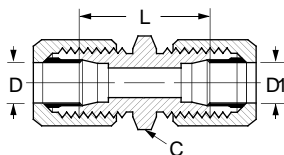
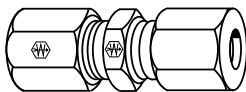

Tube O.D.	Tube O.D.	Catalog Number	Hex C	D	D1	L
1/8	1/8	7305x2•	7/16	.093	.093	1.02
3/16	3/16	7305x3•	7/16	.125	.125	1.11
1/4	1/4	7305x4•	1/2	.203	.203	1.18
5/16	5/16	7305x5•	9/16	.234	.234	1.18
3/8	1/4	7305x6x4•	5/8	.281	.203	1.22
3/8	3/8	7305x6•	5/8	.281	.281	1.24
1/2	3/8	7305x8x6	13/16	.422	.281	1.33
1/2	1/2	7305x8•	13/16	.422	.422	1.42
5/8	5/8	7305x10•	15/16	.500	.500	1.61
3/4	3/4	7305x12•	1-1/8	.656	.656	1.81
7/8	7/8	7305x14	1-1/4	.718	.718	1.81
1	1	7305x16•	1-3/8	.875	.875	1.81
1-1/4	1-1/4	7305x20	1-11/16	1.093	1.093	1.89
1-1/2	1-1/2	7305x24	2	1.344	1.344	1.96
2	2	7305x32	2-5/8	1.813	1.813	2.11

Large Hex Union
Stainless Steel No. **7318x**
(Ref. SAE No. 080119)

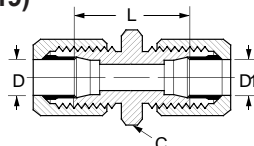
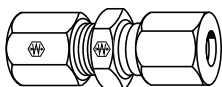

Tube O.D.	Tube O.D.	Catalog Number	Hex C	D	D1	L
1/4	1/4	7306x4•	11/16	.203	.203	1.18
3/8	3/8	7306x6•	13/16	.281	.281	1.24
1/2	3/8	7306x8x6•	1	.422	.281	1.33
1/2	1/2	7306x8•	1	.422	.422	1.42
3/4	3/4	7306x12•	1-3/8	.656	.656	1.81
1	1	7306x16	1-5/8	.875	.875	1.81

• Available in stainless steel.

Bulkhead Union

Stainless Steel No. 7337x
(Ref. SAE No. 080601)

Bulkhead nut included, for replacement nuts see page 201.

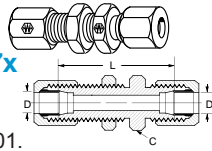

Tube O.D.	Catalog Number	Hex C	D	L
1/4	7325x4•	11/16	.203	1.89
3/8	7325x6•	13/16	.281	1.98
1/2	7325x8•	1	.422	2.22
3/4	7325x12•	1-3/8	.656	2.72
1	7325x16	1-5/8	.875	2.72

Male Connector

Stainless Steel No. 7217x
(Ref. SAE No. 080102)

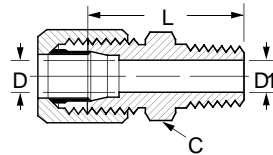
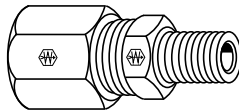

Tube O.D.	Male Pipe Thread	Catalog Number	Hex C	D	D1 Opt.	L
1/8	1/8	7205x2•	7/16	.093	.188	1.04
1/8	1/4	7205x2x4•	9/16	.093	.281	1.25
3/16	1/8	7205x3•	7/16	.125	.188	1.09
1/4	1/8	7205x4•	1/2	.203	.188	1.12
1/4	1/4	7205x4x4•	9/16	.203	.281	1.32
1/4	3/8	7205x4x6•	3/4	.203	.406	1.33
1/4	1/2	7205x4x8•	7/8	.203	.531	1.58
5/16	1/8	7205x5•	9/16	.234	.188	1.12
5/16	1/4	7205x5x4•	9/16	.234	.281	1.32
3/8	1/8	7205x6x2•	5/8	.281	.188	1.15
3/8	1/4	7205x6•	5/8	.281	.281	1.34
3/8	3/8	7205x6x6•	3/4	.281	.406	1.35
3/8	1/2	7205x6x8•	7/8	.281	.531	1.60
1/2	1/4	7205x8x4•	13/16	.422	.281	1.44
1/2	3/8	7205x8•	13/16	.422	.406	1.44
1/2	1/2	7205x8x8•	7/8	.422	.531	1.69
1/2	3/4	7205x8x12•	1-1/8	.422	.719	1.76
5/8	3/8	7205x10x6•	15/16	.500	.406	1.56
5/8	1/2	7205x10•	15/16	.500	.531	1.75
3/4	1/2	7205x12x8•	1-1/8	.656	.531	1.88
3/4	3/4	7205x12•	1-1/8	.656	.719	1.88
7/8	3/4	7205x14•	1-1/4	.718	.719	1.88
1	3/4	7205x16x12•	1-3/8	.875	.719	1.88
1	1	7205x16•	1-3/8	.875	.938	2.07
1-1/4	1-1/4	7205x20	1-11/16	1.093	1.250	2.18
1-1/2	1-1/2	7205x24	2	1.344	1.500	2.28
2	2	7205x32	2-5/8	1.813	1.938	2.46

Female Connector

Stainless Steel No. 7267x
(Ref. SAE No. 080103)

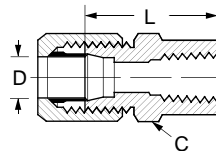
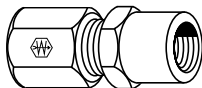

Tube O.D.	Fem. Pipe Thread	Catalog Number	Hex C	D	L
1/8	1/8	7255x2•	9/16	.093	1.05
3/16	1/8	7255x3•	9/16	.125	1.08
1/4	1/8	7255x4•	9/16	.203	1.09
1/4	1/4	7255x4x4•	3/4	.203	1.20
5/16	1/8	7255x5•	9/16	.234	1.08
3/8	1/4	7255x6•	3/4	.281	1.31
3/8	3/8	7255x6x6•	7/8	.281	1.40
1/2	1/4	7255x8x4•	7/8	.422	1.38
1/2	3/8	7255x8•	7/8	.422	1.47
1/2	1/2	7255x8x8•	1-1/8	.422	1.63
5/8	1/2	7255x10	1-1/8	.500	1.76
3/4	3/4	7255x12•	1-3/8	.656	1.89
7/8	3/4	7255x14	1-3/8	.718	1.86
1	1	7255x16•	1-5/8	.875	2.13
1-1/4	1-1/4	7255x20	2	1.093	2.22

Straight Thread O-Ring Connector

Stainless Steel No. 7327x
(Ref. SAE No. 080120)

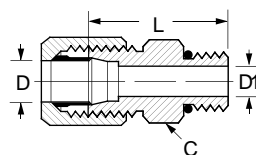
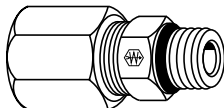

Tube O.D.	Port Size	Catalog Number	Hex C	D	L	D1 Opt.
3/16	3/16	7315x3	1/2	.125	1.04	–
1/4	1/4	7315x4•	9/16	.203	1.13	–
1/4	5/16	7315x4x5•	5/8	.203	1.13	–
1/4	3/8	7315x4x6•	11/16	.203	1.19	.281
5/16	5/16	7315x5	5/8	.234	1.13	–
3/8	3/8	7315x6•	11/16	.281	1.21	–
3/8	1/2	7315x6x8	7/8	.281	1.29	.422
1/2	1/2	7315x8•	7/8	.422	1.38	–
1/2	5/8	7315x8x10	1	.422	1.51	.500
1/2	3/4	7315x8x12•	1-1/4	.422	1.67	.656
5/8	5/8	7315x10•	1	.500	1.57	–
3/4	3/4	7315x12•	1-1/4	.656	1.79	–
3/4	1	7315x12x16	1-1/2	.656	1.82	.876
7/8	7/8	7315x14	1-3/8	.718	1.79	–
1	3/4	7315x16x12	1-1/2	.875	1.82	.656
1	1	7315x16•	1-1/2	.875	1.82	–
1-1/4	1-1/4	7315x20	1-7/8	1.093	1.90	–
1-1/2	1-1/2	7315x24	2-1/8	1.344	1.97	–
2	2	7315x32	2-3/4	1.813	2.13	–

Replacement O-rings page 207.

• Available in stainless steel.

45° Male Elbow
Stainless Steel No. **7367x**
(Ref. SAE No. 080302)

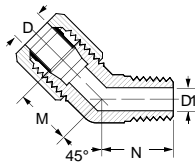
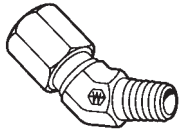

Tube O.D.	Male Pipe Thread	Catalog Number	D	D1	M	N	Across Flats
1/4	1/8	7355x4•	.203	.188	.70	.64	7/16
1/4	1/4	7355x4x4•	.203	.281	.83	.86	9/16
5/16	1/8	7355x5	.234	.188	.75	.64	9/16
3/8	1/4	7355x6•	.281	.281	.83	.86	9/16
1/2	3/8	7355x8•	.422	.406	.98	.95	3/4
5/8	1/2	7355x10	.500	.531	1.08	1.17	7/8
3/4	3/4	7355x12	.656	.719	1.27	1.20	1-1/16
1	1	7355x16	.875	.938	1.36	1.48	1-5/16

90° Union Elbow
Stainless Steel No. **7517x**
(Ref. SAE No. 080201)

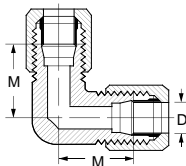
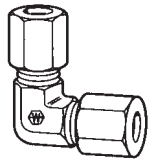

Tube O.D.	Catalog Number	D	M	Across Flats
1/4	7505x4•	.203	.89	7/16
5/16	7505x5	.234	.95	1/2
3/8	7505x6•	.281	1.05	9/16
1/2	7505x8•	.422	1.25	3/4
5/8	7505x10•	.500	1.42	7/8
3/4	7505x12•	.656	1.58	1-1/16
7/8	7505x14•	.718	1.66	1-5/16
1	7505x16•	.875	1.73	1-5/16
1-1/4	7505x20	1.093	1.89	1-5/8
1-1/2	7505x24	1.346	2.02	1-7/8

90° Male Elbow
Stainless Steel No. **7417x**
(Ref. SAE No. 080202)

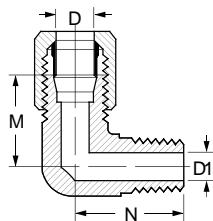
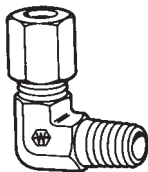

Tube O.D.	Male Pipe Thread	Catalog Number	D	D1	M	N	Across Flats
1/8	1/8	7405x2•	.093	.188	.77	.72	7/16
3/16	1/8	7405x3	.125	.188	.83	.72	7/16
1/4	1/8	7405x4•	.203	.188	.89	.78	7/16
1/4	1/4	7405x4x4•	.203	.281	1.03	1.09	9/16
5/16	1/8	7405x5•	.234	.188	.95	.81	1/2
5/16	1/4	7405x5x4•	.234	.281	1.03	1.09	9/16
3/8	1/8	7405x6x2•	.281	.188	1.05	.90	9/16
3/8	1/4	7405x6•	.281	.281	1.05	1.09	9/16
3/8	3/8	7405x6x6•	.281	.406	1.16	1.22	3/4
3/8	1/2	7405x6x8•	.281	.531	1.24	1.47	7/8
1/2	1/4	7405x8x4•	.422	.281	1.25	1.22	3/4
1/2	3/8	7405x8•	.422	.406	1.25	1.22	3/4
1/2	1/2	7405x8x8•	.422	.531	1.35	1.47	7/8
5/8	3/8	7405x10x6•	.500	.406	1.42	1.28	7/8
5/8	1/2	7405x10•	.500	.531	1.42	1.47	7/8
3/4	1/2	7405x12x8	.656	.531	1.58	1.59	1-1/16
3/4	3/4	7405x12•	.656	.719	1.58	1.59	1-1/16
7/8	3/4	7405x14	.718	.719	1.62	1.69	1-5/16
1	3/4	7405x16x12	.875	.719	1.73	1.78	1-5/16
1	1	7405x16•	.875	.938	1.73	1.97	1-5/16
1-1/4	1-1/4	7405x20	1.093	1.250	1.89	2.38	1-5/8
1-1/2	1-1/2	7405x24	1.344	1.500	2.02	2.64	1-7/8
2	2	7405x32	1.813	1.938	2.45	3.00	2-9/16

90° Female Elbow
Stainless Steel No. **7467x**
(Ref. SAE No. 080203)

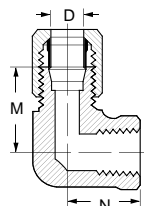
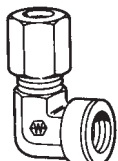

Tube O.D.	Fem. Pipe Thread	Catalog Number	D	M	N	Across Flats
1/4	1/8	7455x4•	.203	.89	.66	9/16
1/4	1/4	7455x4x4•	.203	1.03	.88	3/4
3/8	1/4	7455x6•	.281	1.05	.88	3/4
3/8	3/8	7455x6x6•	.281	1.14	1.02	7/8
1/2	3/8	7455x8•	.422	1.23	1.02	7/8
1/2	1/2	7455x8x8•	.422	1.35	1.23	1-1/16
5/8	1/2	7455x10•	.500	1.42	1.23	1-1/16
3/4	3/4	7455x12•	.656	1.58	1.36	1-5/16
7/8	3/4	7455x14	.718	1.66	1.42	1-5/16
1	1	7455x16	.875	1.73	1.62	1-5/8

• Available in stainless steel.

90° Elbow - Straight Thread O-Ring

Stainless Steel No. **7527x**
(Ref. SAE No. 080220)

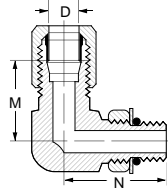
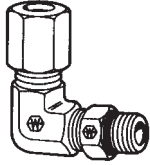

Replacement O-rings page 207.

Tube O.D.	Port Size	Catalog Number	D	M	N	Across Flats
1/4	1/4	7515x4•	.203	.89	1.03	7/16
5/16	5/16	7515x5	.234	.96	1.13	9/16
3/8	3/8	7515x6•	.281	1.05	1.25	9/16
1/2	1/2	7515x8•	.422	1.25	1.45	3/4
5/8	5/8	7515x10•	.500	1.42	1.70	7/8
3/4	3/4	7515x12•	.656	1.58	1.94	1-1/16
1	3/4	7515x16x12	.875	1.73	2.05	1-5/16
1	1	7515x16•	.875	1.73	2.05	1-5/16
1-1/4	1-1/4	7515x20	1.093	1.89	2.25	1-5/8

Union Tee

Stainless Steel No. **7717x**
(Ref. SAE No. 080401)

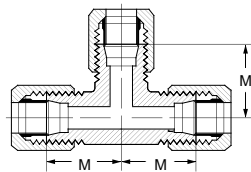
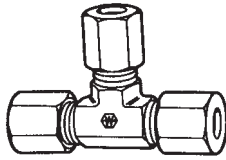

Tube O.D.	Catalog Number	D	M	Across Flats
3/16	7705x3	.125	.83	7/16
1/4	7705x4•	.203	.89	7/16
5/16	7705x5•	.234	.95	9/16
3/8	7705x6•	.281	1.05	9/16
1/2	7705x8•	.422	1.25	3/4
5/8	7705x10•	.500	1.42	7/8
3/4	7705x12•	.656	1.58	1-1/16
7/8	7705x14	.718	1.62	1-5/16
1	7705x16•	.875	1.73	1-5/16

Male Run Tee

Stainless Steel No. **7767x**
(Ref. SAE No. 080424)

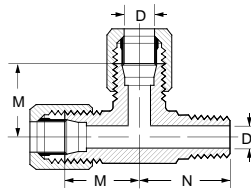
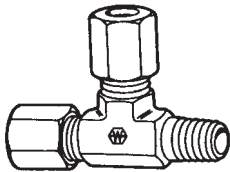

Tube O.D.	Male Pipe Thread	Catalog Number	D	D1	M	N	Across Flats
1/4	1/8	7755x4•	.203	.188	.89	.78	7/16
1/4	1/4	7755x4x4x4•	.203	.281	1.03	1.09	9/16
3/8	1/4	7755x6•	.281	.281	1.05	1.09	9/16
1/2	3/8	7755x8	.422	.422	1.25	1.22	3/4
1/2	1/2	7755x8x8x8•	.422	.531	1.35	1.47	7/8
5/8	1/2	7755x10	.500	.531	1.42	1.47	7/8
3/4	3/4	7755x12	.656	.719	1.58	1.59	1-1/16
1	1	7755x16	.875	.938	1.73	1.97	1-5/16

Female Run Tee

(Ref. SAE No. 080426)

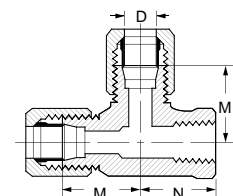
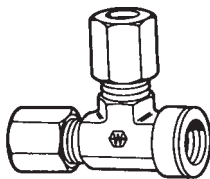

Tube O.D.	Fem. Pipe Thread	Catalog Number	D	M	N	Across Flats
1/4	1/8	7805x4	.203	.89	.66	9/16
1/4	1/4	7805x4x4x4	.203	1.03	.88	3/4
3/8	1/4	7805x6	.281	1.05	.88	3/4
1/2	3/8	7805x8	.422	1.23	1.02	7/8
5/8	1/2	7805x10	.500	1.42	1.23	1-1/16
3/4	3/4	7805x12	.656	1.58	1.36	1-5/16

• Available in stainless steel.

Straight Thread O-Ring Run Tee
Stainless Steel No. **7728x**
(Ref. SAE No. 080428)

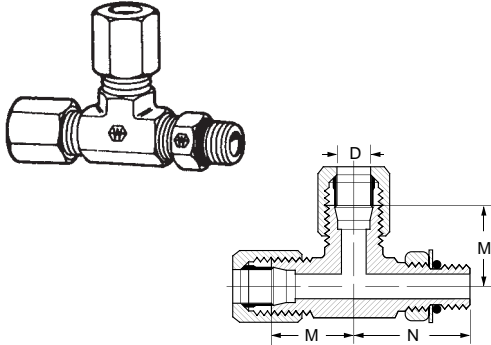

Replacement O-rings page 207.

Tube O.D.	Port Size	Catalog Number	D	M	N	Across Flats
1/4	1/4	7716x4•	.203	.89	1.03	7/16
3/8	3/8	7716x6•	.281	1.05	1.25	9/16
1/2	1/2	7716x8•	.422	1.25	1.45	3/4

Male Branch Tee
Stainless Steel No. **7617x**
(Ref. SAE No. 080425)

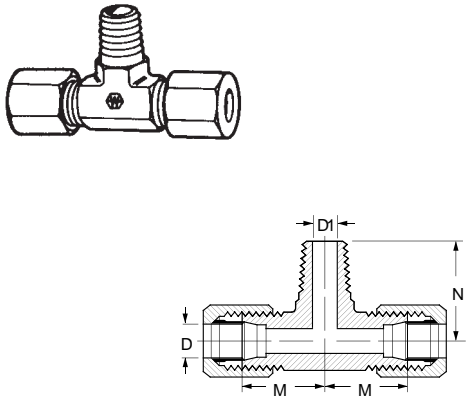

Tube O.D.	Male Pipe Thread	Catalog Number	D	D1	M	N	Across Flats
1/4	1/8	7605x4•	.203	.188	.89	.78	7/16
1/4	1/4	7605x4x4x4•	.203	.281	1.03	1.09	9/16
5/16	1/8	7605x5	.234	.188	.95	.81	9/16
3/8	1/4	7605x6•	.281	.281	1.05	1.09	9/16
1/2	3/8	7605x8•	.422	.406	1.25	1.22	3/4
1/2	1/2	7605x8x8x8•	.422	.531	1.35	1.47	7/8
5/8	1/2	7605x10	.500	.531	1.42	1.47	7/8
3/4	3/4	7605x12	.656	.719	1.58	1.59	1-1/16
1	1	7605x16	.875	.938	1.73	1.97	1-5/16

Female Branch Tee
Stainless Steel No. **7667x**
(Ref. SAE No. 080427)

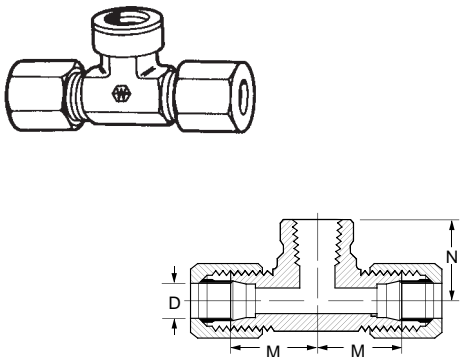

Tube O.D.	Female Pipe Thread	Catalog Number	D	M	N	Across Flats
1/4	1/8	7655x4•	.203	.89	.66	9/16
1/4	1/4	7655x4x4x4•	.203	1.03	.88	3/4
3/8	1/4	7655x6•	.281	1.05	.88	3/4
1/2	3/8	7655x8•	.422	1.23	1.02	7/8
5/8	1/2	7655x10	.500	1.42	1.23	1-1/16
3/4	3/4	7655x12	.656	1.58	1.36	1-5/16
7/8	3/4	7655x14	.718	1.62	1.42	1-5/16
1	1	7655x16	.875	1.73	1.62	1-5/8
1-1/4	1-1/4	7655x20	1.093	2.08	1.70	1-7/8

• Available in stainless steel.

Straight Thread O-Ring Branch Tee

Stainless Steel No. **7727x**
(Ref. SAE No. 080429)

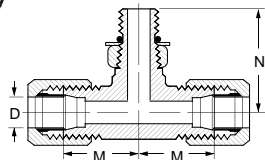
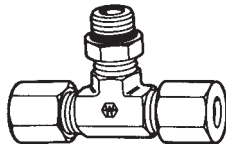

Replacement O-rings see below.

Tube O.D.	Port Size	Catalog Number	D	M	N	Across Flats
1/4	1/4	7715x4*	.203	.89	1.03	7/16
3/8	3/8	7715x6*	.281	1.05	1.25	9/16
1/2	1/2	7715x8	.422	1.25	1.45	3/4

Cross

Stainless Steel No. **7967x**
(Ref. SAE No. 080501)

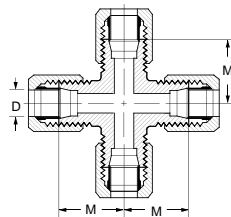
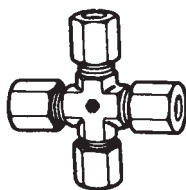

*Brazed construction.

Tube O.D.	Catalog Number	D	M	Across Flats
1/4	7955x4*	.203	.89	9/16
3/8	7955x6*	.281	1.05	9/16
1/2	7955x8	.422	1.25	3/4

Straight Thread O-Ring

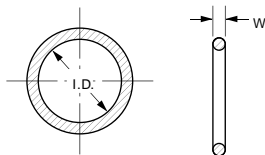

Material: Buna-N 90 Durometer
Temperature Range: -40°F to +250°F
(-40°C to +121°C)
Standard O-ring complies with SAE J515 Type CH.

Tube O.D.	Catalog Number	W	I.D.
1/16	7629x1	.058 ± .003	.185 ± .005
1/8	7629x2	.064 ± .003	.239 ± .005
3/16	7629x3	.064 ± .003	.301 ± .005
1/4	7629x4	.072 ± .003	.351 ± .005
5/16	7629x5	.072 ± .003	.414 ± .005
3/8	7629x6	.078 ± .003	.468 ± .005
7/16	7629x7	.082 ± .003	.530 ± .005
1/2	7629x8	.087 ± .003	.644 ± .005
5/8	7629x10	.097 ± .003	.755 ± .005
3/4	7629x12	.116 ± .004	.924 ± .006
7/8	7629x14	.116 ± .004	1.048 ± .006
1	7629x16	.116 ± .004	1.171 ± .006
1-1/4	7629x20	.118 ± .004	1.475 ± .010
1-1/2	7629x24	.118 ± .004	1.720 ± .010
2	7629x32	.118 ± .004	2.337 ± .010

• Available in stainless steel.

Adapter Used With Standard JIC Female Swivel End (SAE Code 61)

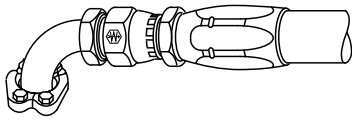

Weatherhead® split flange adapter eliminates the need for special hose ends. Interconnect pumps and valves with SAE flange outlets using low cost standard hose assemblies to replace equipment hose assembly.

Material: Low carbon steel.

Plating: Zinc, Yellow Dichromate finish.

Pressure: Code 61 – 3000 PSI working pressure (32 sizes 2500 PSI W.P.).

Label Set: FS-300

Note: See page 223 for hydraulic o-ring assortment

Straight

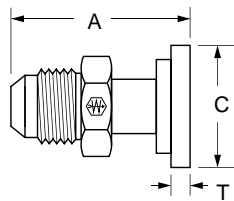

Tube Size	Code 61 Flange Size	Catalog Number	A	Dia. C	T	Thread Size
1/2	1/2	50008	2.66	1.188	.265	3/4-16
1/2	3/4	50008x12	2.72	1.500	.265	3/4-16
3/4	3/4	50012	2.62	1.500	.265	1 1/16-12
1	1	50016	2.74	1.750	.315	1 5/16-12
1	1-1/4	50016x20	2.74	2.000	.315	1 5/16-12
1-1/4	1	50020x16	2.80	1.750	.315	1 5/8-12
1-1/4	1-1/4	50020	3.27	2.000	.315	1 5/8-12
1-1/2	1-1/2	50024	3.42	2.375	.315	1 7/8-12
2	2	50032	4.24	2.812	.375	2 1/2-12

45° Elbow

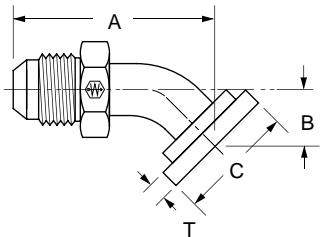

Tube Size	Code 61 Flange Size	Catalog Number	A	B	Dia. C	T	Thread Size
1/2	1/2	54508	2.91	.78	1.188	.265	3/4-16
1/2	3/4	54508x12	2.93	.84	1.500	.265	3/4-16
3/4	3/4	54512	3.28	1.03	1.500	.265	1 1/16-12
1	1	54516	3.61	1.06	1.750	.315	1 5/16-12
1	1-1/4	54516x20	3.61	1.06	2.000	.315	1 5/16-12
1-1/4	1	54520x16	3.67	1.06	1.750	.315	1 5/8-12
1-1/4	1-1/4	54520	3.36	1.15	2.000	.315	1 5/8-12
1-1/2	1-1/2	54524	4.61	1.41	2.375	.315	1 7/8-12
2	2	54532	6.28	2.00	2.812	.375	2 1/2-12

90° Elbow

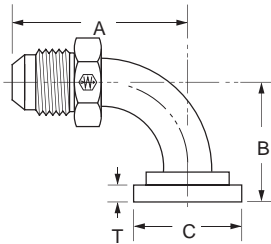

Tube Size	Code 61 Flange Size	Catalog Number	A	B	Dia. C	T	Thread Size
1/2	1/2	59008	2.54	1.63	1.188	.265	3/4-16
1/2	3/4	59008x12	2.54	1.69	1.500	.265	3/4-16
3/4	3/4	59012	2.79	2.19	1.500	.265	1 1/16-12
1	1	59016	3.61	2.38	1.750	.315	1 5/16-12
1	1-1/4	59016x20	3.61	2.38	2.000	.315	1 5/16-12
1-1/4	1	59020x16	3.66	2.38	1.750	.315	1 5/8-12
1-1/4	1-1/4	59020	3.52	2.62	2.000	.315	1 5/8-12
1-1/2	1-1/2	59024	4.32	3.12	2.375	.315	1 7/8-12
2	2	59032	5.95	4.50	2.812	.375	2 1/2-12

Split Flange Kits – SAE Standard Pressure Series (Code 61) SAE J518

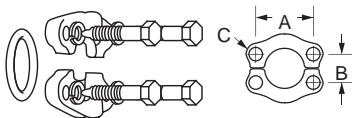

Material: Buna-N 90 Durometer

Temperature Range: -40°F to +250°F (-40°C to +121°C)

Standard O-ring complies with SAE specifications SAE J515 Type CH (See page 138 for O-ring compound and application chart)

Nominal Flange Size	Catalog Number Complete Kit	Flange Halves 2 Req'd.	Included in kit.			A	B	C	Bolt Torque Range Lb.-in.
			O-Ring	Bolts	Lock Washer				
1/2	SFK-08	8x251	8x252	8x853	8x254	1.50	.69	11/32	175-225
3/4	SFK-12	12x251	12x252	12x853	12x254	1.88	.88	13/32	250-350
1	SFK-16	16x251	16x252	16x853	16x254	2.06	1.03	13/32	325-425
1-1/4	SFK-20	20x251	20x252	20x853	20x254	2.31	1.19	15/32	425-550
1-1/2	SFK-24	24x251	24x252	24x853	24x254	2.75	1.41	17/32	550-700
2	SFK-32	32x251	32x252	24x853	24x254	3.06	1.69	17/32	650-800

Flanges conform to SAE J518.

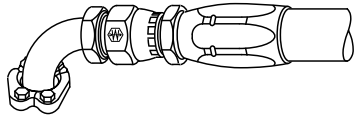

Adapter Used With Standard JIC Female Swivel End (SAE Code 62)

Weatherhead® split flange adapter eliminates the need for special hose ends. Interconnect pumps and valves with SAE flange outlets using low cost standard hose assemblies to replace original equipment hose assembly.

Material: AISI/SAE 12L14 carbon steel.

Plating: Zinc, Yellow Dichromate finish.

Pressure: Code 62 – 5000 PSI working pressure.

Label Set: FS-300

Note: See page 223 for hydraulic o-ring assortment.

Straight

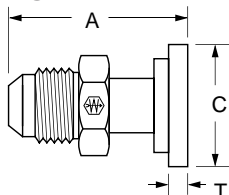

Tube Size	Code 62 Flange Size	Catalog Number	A	Dia. C	T	Thread Size
1/2	1/2	60008	2.32	1.25	.305	3/4-16
3/4	3/4	60012	2.64	1.62	.345	1 1/16-12
1	1	60016	3.44	1.88	.375	1 5/16-12
1-1/4	1-1/4	60020	3.97	2.12	.405	1 5/8-12
1-1/2	1-1/2	60024	4.97	2.50	.495	1 7/8-12
2	2	60032	5.22	3.12	.495	2 1/2-12

45° Elbow

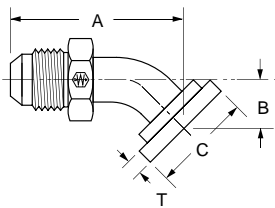

Tube Size	Code 62 Flange Size	Catalog Number	A	B	Dia. C	T	Thread Size
1/2	1/2	64508	2.12	1.10	1.25	.305	3/4-16
3/4	3/4	64512	2.56	1.32	1.62	.345	1 1/16-12
1	1	64516	3.34	1.43	1.88	.375	1 5/16-12
1-1/4	1-1/4	64520	3.49	1.87	2.12	.405	1 5/8-12
1-1/2	1-1/2	64524	6.31	3.07	2.50	.495	1 7/8-12
2	2	64532	8.19	3.74	3.12	.495	2 1/2-12

90° Elbow

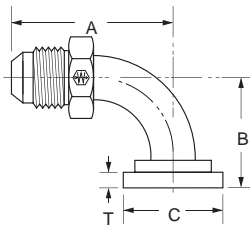

Tube Size	Code 62 Flange Size	Catalog Number	A	B	Dia. C	T	Thread Size
1/2	1/2	69008	1.57	2.11	1.25	.305	3/4-16
3/4	3/4	69012	1.93	2.56	1.62	.345	1 1/16-12
1	1	69016	2.35	2.90	1.88	.375	1 5/16-12
1-1/4	1-1/4	69020	2.91	3.46	2.12	.405	1 5/8-12
1-1/2	1-1/2	69024	5.44	6.53	2.50	.495	1 7/8-12
2	2	69032	7.38	8.22	3.12	.495	2 1/2-12

Split Flange Kits – SAE High Pressure Series (Code 62) SAE J518

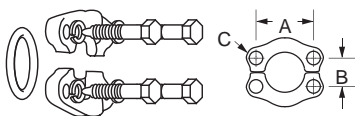

Material: Buna-N 90 Durometer
Temperature Range: -40°F to +250°F (-40°C to +121°C)
 Standard O-ring complies with SAE specifications SAE J515 Type CH (See page 138 for O-ring compound and application chart)

Nominal Flange Size	Catalog Number Complete Kit	Flange Halves 2 Req'd.	Included in kit.				A	B	C	Bolt Torque Range Lb.-in.
			O-Ring	Lock Washer	Bolts	Lock Washer				
1/2	SFK62-8	8x262	8x252	8x863	8x254	1.57	.72	5/16	175-225	
3/4	SFK62-12	12x262	12x252	12x863	12x254	2.00	.94	13/32	300-400	
1	SFK62-16	16x262	16x252	16x863	16x254	2.25	1.09	15/32	500-600	
1-1/4	SFK62-20	20x262	20x252	20x863	20x254	2.63	1.25	17/32	750-900	
1-1/2	SFK62-24	24x262	24x252	24x863	24x264	3.12	1.44	21/32	1400-1600	
2	SFK62-32	32x262	32x252	32x863	32x264	3.81	1.75	25/32	2400-2600	

Flanges conform to SAE J518.

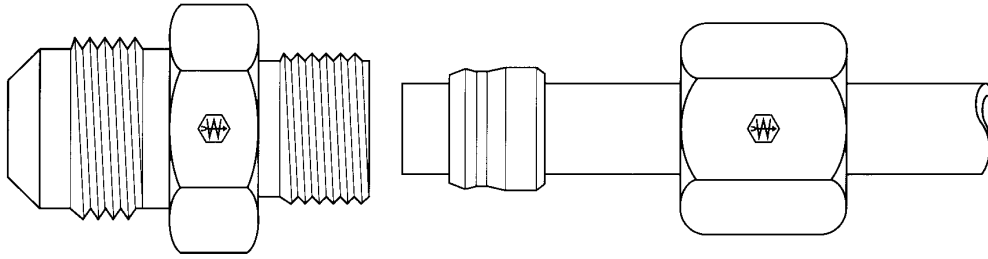

Metric Tube O.D.	6	8	10	12	14	15	16	18	20	22	25	28	30	38
Light	M12x1.5	M14x1.5	M16x1.5	M18x1.5	–	M22x1.5	–	M26x1.5	–	M30x2.0	–	M36x2.0	–	–
Heavy	M14x1.5	M16x1.5	M18x1.5	M20x1.5	M22x1.5	–	M24x1.5	–	M30x2.0	–	M36x2.0	–	M42x2.0	M52x2.0

• **Typical Application**

Used in applications to adapt connections made to DIN (Deutsche Industrie Norme) specifications to male 37° JIC Flare.

• **Sealing Method**

Three-Piece Flareless Bite Type or 60° or 24° Tube Seat, or 37° Flare.

• **Vibration Rating**

Three-Piece Flareless Bite Type or 60° or 24° Tube Seat. Fair Resistance.

• **Material**

Carbon Steel - SAE 12L14

• **Plating**

Bodies and Sleeves - Zinc Yellow Dichromate Finish
Nuts - Phosphate Coating.

• **Advantages**

Provides an adapter to convert a metric hose assembly to JIC 37° allowing the use of standard hose and end fittings. Can also be used in the repair of metric tubing.

• **Presetting Instructions**

1. Preset with preset tool. All sleeves should be preset in tool prior to installation.
2. Lubricate the sleeve, nut and threads with a good grade of lubricant compatible with the system fluid.
3. Slide the nut and sleeve on the tubing. The thicker end of the sleeve should be towards the nut.
4. Insert the tube into the preset tool making sure it is bottomed on the tube stop. Tighten the nut by hand as much as possible.

5. On the tube sizes up to and including 18mm O.D., tighten the nut 1-1/2 turns past hand tight. For larger tube O.D.'s, tighten the nut 1-1/4 turns past hand tight.
6. To inspect preset, mark the nut location and remove nut.
7. To reinstall, tighten the nut 1/6 turn (one hex flat) past the previous nut location.

• **Ordering Information**

Order individually by catalog number. Preset tools found on page 222.

Metric Flareless Sleeve

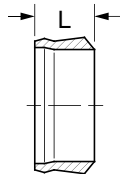
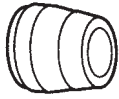

Tube O.D. (mm)	Catalog Number	L (mm)
6	7165x6MM	8.5
8	7165x8MM	8.5
10	7165x10MM	9.5
12	7165x12MM	9.5
14	7165x14MM	10.0
15	7165x15MM	10.0
16	7165x16MM	10.0
18	7165x18MM	10.0
20	7165x20MM	11.5
22	7165x22MM	11.5
25	7165x25MM	11.5
28	7165x28MM	11.5
30	7165x30MM	13.5
38	7165x38MM	13.5

Metric Flareless Nut Light Series (DIN 3901/3902L)

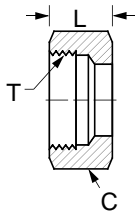
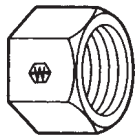

Tube O.D. (mm)	Catalog Number	T Thread	Hex C (mm)	L (mm)
6	ML7105x6	M12x1.5	14	14.5
8	ML7105x8	M14x1.5	17	14.5
10	ML7105x10	M16x1.5	19	15.5
12	ML7105x12	M18x1.5	22	15.5
15	ML7105x15	M22x1.5	27	17.0
18	ML7105x18	M26x1.5	32	18.0
22	ML7105x22	M30x2.0	36	20.0
28	ML7105x28	M36x2.0	41	21.0

Metric Flareless Nut Heavy Series (DIN 3901/3902S)

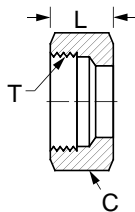
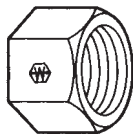

Tube O.D. (mm)	Catalog Number	T Thread	Hex C (mm)	L (mm)
6	MH7105x6	M14x1.5	17	16.5
8	MH7105x8	M16x1.5	19	16.5
10	MH7105x10	M18x1.5	22	17.5
12	MH7105x12	M20x1.5	24	17.5
14	MH7105x14	M22x1.5	27	20.5
16	MH7105x16	M24x1.5	30	20.5
20	MH7105x20	M30x2.0	36	24.0
25	MH7105x25	M36x2.0	46	27.0
30	MH7105x30	M42x2.0	50	29.0
38	MH7105x38	M52x2.0	60	32.5

NOTE: Multiply millimeters (mm) by 0.03937 to obtain inches.

**Male JIC 37° to 24° Metric Tube
Seat (Light)**
(DIN 3901/3902L)

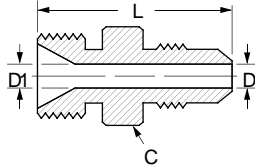
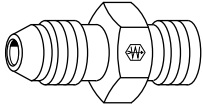

Tube O.D.	Tube O.D. (mm)	Catalog Number	Metric Thread	Hex C	D	D1	L
1/4	6	MC5206x4x6	M12x1.5	5/8	.171	.171	1.22
3/8	8	MC5206x6x8	M14x1.5	3/4	.297	.240	1.22
1/2	10	MC5206x8x10	M16x1.5	7/8	.391	.322	1.41
1/2	12	MC5206x8x12	M18x1.5	15/16	.391	.398	1.48
5/8	15	MC5206x10x15	M22x1.5	1-1/16	.484	.478	1.70
3/4	18	MC5206x12x18	M26x1.5	1-3/4	.609	.596	1.91

**Male JIC 37° to 24° Metric Tube
Seat (Heavy)**
(DIN 3901/3902S)

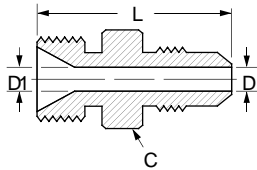
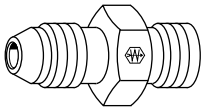

Tube O.D.	Tube O.D. (mm)	Catalog Number	Metric Thread	Hex C	D	D1	L
3/8	6	MC5208x6x6	M14x1.5	3/4	.297	.167	1.22
1/2	10	MC5208x8x10	M18x1.5	15/16	.391	.283	1.48
5/8	14	MC5208x10x14	M22x1.5	1-1/16	.484	.397	1.70
3/4	16	MC5208x12x16	M24x1.5	1-1/8	.609	.476	1.77

**Male JIC 37° to 60° Metric Tube
Seat**
(DIN 7631)

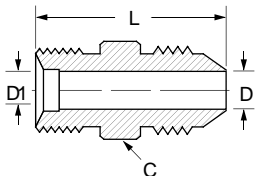
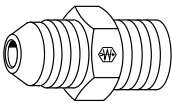

Tube O.D.	Tube O.D. (mm)	Catalog Number	Metric Thread	Hex C	D	D1	L
1/4	6	MC5207x4x6	M12x1.5	1/2	.171	.157	1.22
3/8	8	MC5207x6x8	M14x1.5	5/8	.297	.242	1.22
3/8	10	MC5207x6x10	M16x1.5	7/8	.297	.321	1.32
1/2	12	MC5207x8x12	M18x1.5	15/16	.391	.394	1.48
5/8	15	MC5207x10x15	M22x1.5	1-1/16	.472	.472	1.52
3/4	18	MC5207x12x18	M26x1.5	1-1/8	.609	.596	1.91

**Male JIC 37° to Male Metric
Standpipe**
(DIN 7631)

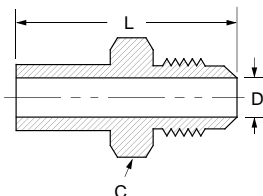
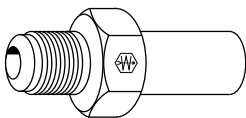

Tube O.D.	Tube O.D. (mm)	Catalog Number	Hex C	L	D
1/4	6MM	MC5019x4x6	9/16	1.58	.16
1/4	8MM	MC5019x4x8	9/16	1.68	.17
3/8	10MM	MC5019x6x10	3/4	1.67	.28
1/2	12MM	MC5019x8x12	7/8	1.97	.32
1/2	14MM	MC5019x8x14	7/8	1.89	.39
5/8	15MM	MC5019x10x15	1	2.03	.43
5/8	16MM	MC5019x10x16	1	2.07	.47
3/4	16MM	MC5019x12x16	1-1/4	2.22	.47
3/4	18MM	MC5019x12x18	1-1/4	2.12	.55
3/4	20MM	MC5019x12x20	1-1/4	2.38	.61
1	22MM	MC5019x16x22	1-1/2	2.21	.67
1	25MM	MC5019x16x25	1-1/2	2.54	.79

NOTE: Multiply millimeters (mm) by 0.03937 to obtain inches.

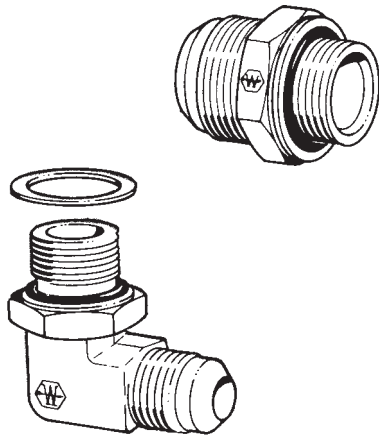

- Typical Application**
 Used in applications to adapt connections and tubing to male and female swivel 37° JIC flare.
- Sealing Method**
 Tapered pipe thread, or o-ring, or 37° flare.
- Vibration Rating**
 Fair resistance.
- Material**
 Carbon Steel – SAE 12L14.
- Plating**
 Zinc yellow dichromate finish.
- Advantages**
 Provides an adapter to convert Metric ports to 37° JIC allowing the use of standard hose and end fittings. Also metric tubing that can be flared can be adapted to a standard 37° JIC connection by the use of sleeves.
- Ordering Information**
 Order individually by catalog number.

Sleeve 3 Piece Metric (Ref. SAE No. 070115)

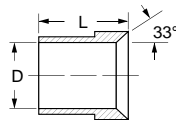

Adapts standard JIC Flare-Twin® fittings for use with metric tubing.

Tube O.D. (Inch Size)	Tube O.D. (Metric Size)	Catalog Number	D	L
1/4	6MM	C5165x4x6MM	.241	.41
5/16	8MM	C5165x5x8MM	.320	.44
3/8	10MM	C5165x6x10MM	.399	.50
1/2	12MM	C5165x8x12MM	.478	.56
5/8	14MM	C5165x10x14MM	.556	.66
5/8	15MM	C5165x10x15MM	.596	.66
5/8	16MM	C5165x10x16MM	.636	.66
3/4	18MM	C5165x12x18MM	.717	.68
7/8	20MM	C5165x14x20MM	.793	.76
7/8	22MM	C5165x14x22MM	.866	.76
1	25MM	C5165x16x25MM	.990	.78
1-1/4	30MM	C5165x20x30MM	1.191	.91
1-1/4	32MM	C5165x20x32MM	1.270	.91
1-1/2	38MM	C5165x24x38MM	1.500	1.12

Male JIC 37° to Male Metric Straight Thread Connector (Port Per ISO 9974)

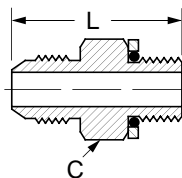

Replacement retaining rings and O-rings page 214.

Tube O.D.	Male Metric Thread	Catalog Number	L	Hex C
1/4	M10x1.0	MC5315x4x10	1.18	5/8
1/4	M12x1.5	MC5315x4x12	1.22	5/8
1/4	M14x1.5	MC5315x4x14	1.22	3/4
3/8	M14x1.5	MC5315x6x14	1.22	3/4
3/8	M16x1.5	MC5315x6x16	1.32	7/8
1/2	M18x1.5	MC5315x8x18	1.48	15/16
1/2	M22x1.5	MC5315x8x22	1.61	1-1/16
5/8	M20x1.5	MC5315x10x20	1.71	1
3/4	M22x1.5	MC5315x12x22	1.81	1-1/8
3/4	M27x2.0	MC5315x12x27	1.95	1-1/4
1	M33x2.0	MC5315x16x33	2.03	1-5/8
1-1/4	M42x2.0	MC5315x20x42	2.19	2

NOTE: Multiply millimeters (mm) by 0.03937 to obtain inches.

Female JIC 37° Swivel to Male Metric Taper Pipe Thread (Pipe Thread Per DIN 3852)

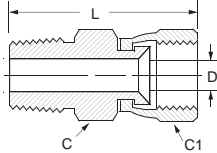
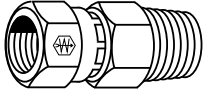

Tube O.D.	Metric Taper Pipe Thread	Catalog Number	Hex C	Hex C1	D	L
1/4	M10 x 1.0	M9700x4x6	9/16	9/16	.172	1.25
5/16	M12 x 1.5	M9700x5x8	11/16	5/8	.234	1.54
3/8	M14 x 1.5	M9700x6x10	11/16	11/16	.297	1.60
1/2	M16 x 1.5	M9700x8x12	7/8	7/8	.391	1.78
5/8	M20 x 1.5	M9700x10x14	1	1	.484	1.91
3/4	M24 x 1.5	M9700x12x20	1-1/8	1-1/8	.609	2.04
1	M27 x 2.0	M9700x16x25	1-3/8	1-1/2	.845	2.30
1-1/4	M36 x 2.0	M9700x20x32	1-7/8	2	1.079	2.43

90° Elbow - Male JIC 37° to Male Metric Straight Thread (For ISO 9974 Port)

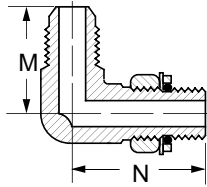
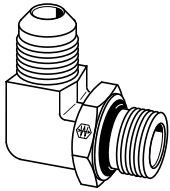

Replacement retaining rings and O-rings see below.

Tube O.D.	Male Metric Thread	Catalog Number	M	N
1/4	M10x1.0	MC5515x4x10	.89	1.03
1/4	M12x1.5	MC5515x4x12	.95	1.09
3/8	M14x1.5	MC5515x6x14	1.06	1.25
3/8	M16x1.5	MC5515x6x16	1.14	1.45
1/2	M18x1.5	MC5515x8x18	1.26	1.47
1/2	M22x1.5	MC5515x8x22	1.33	1.70
5/8	M18x1.5	MC5515x10x18	1.41	1.60
5/8	M20x1.5	MC5515x10x20	1.45	1.70
5/8	M22x1.5	MC5515x10x22	1.45	1.70
3/4	M22x1.5	MC5515x12x22	1.66	1.78
3/4	M27x2.0	MC5515x12x27	1.66	1.94
1	M33x2.0	MC5515x16x33	1.81	2.05

Metric Retaining Ring

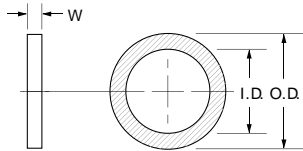

Tube O.D. (mm)	Catalog Number	Ring I.D. (mm)	Ring O.D. (mm)	W (mm)
10	M7630x10	11.33	14.85	1.00
12	M7630x12	13.72	17.85	1.42
14	M7630x14	15.73	19.85	1.42
16	M7630x16	17.73	21.85	1.42
18	M7630x18	19.73	23.80	1.42
20	M7630x20	21.73	25.85	1.42
22	M7630x22	23.73	27.85	1.42
27	M7630x27	29.44	32.85	1.90
33	M7630x33	35.44	39.85	1.90
42	M7630x42	44.44	49.85	1.90

Metric O-Ring (For ISO 9974 Port)

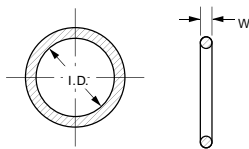

Material: Buna N 90 Durometer
Temperature Range: -40°F to +250°F
 (-40°C to +121°C)

Tube O.D.	Catalog Number	W (mm)	I.D. (mm)
10	M7629x10	1.60	8.10
12	M7629x12	2.40	9.30
14	M7629x14	2.10	11.40
16	M7629x16	2.40	13.30
18	M7629x18	2.40	15.60
20	M7629x20	2.46	18.00
22	M7629x22	2.46	19.80
27	M7629x27	2.95	23.47
33	M7629x33	2.95	29.74
42	M7629x42	3.00	39.20

NOTE: Multiply millimeters (mm) by 0.03937 to obtain inches.

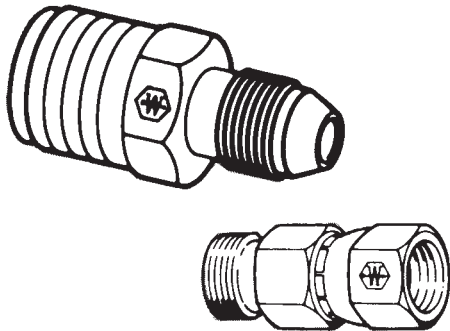

- Typical Application**
 Used in applications to adapt connections made to BSP (British Standard Pipe) specifications to male or female swivel JIC 37° flare.
- Sealing Method**
 Tapered (BSPT) or Parallel Pipe Thread (BSPP), O-ring or 37° flare.
- Vibration Rating**
 Fair resistance.
- Material**
 Carbon Steel – SAE 12L14.
- Plating**
 Zinc with yellow or green dichromate finish.
- Advantages**
 Provides an adapter to convert BSP ports to 37° JIC allowing the use of standard hose and end fittings.
- Ordering Information**
 Order individually by catalog number.

Pipe Size	1/8	1/4	3/8	1/2	5/8	3/4	1	1-1/4
Thread Size	1/8-28	1/4-19	3/8-19	1/2-14	5/8-14	3/4-14	1-11	1-1/4-11

Hex Head Plug

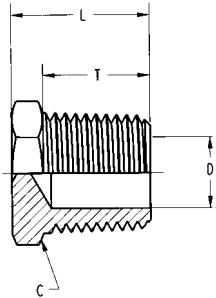
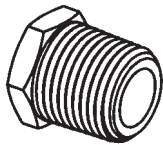

BSPT Pipe Size	Catalog Number	Hex C (mm)	L	T	D Opt. Dia.
1/8	MC3159x2	11	.58	.385	.16
1/4	MC3159x4	14	.76	.577	.25
3/8	MC3159x6	17	.80	.577	.38
1/2	MC3159x8	22	.98	.765	.50
3/4	MC3159x12	27	1.11	.796	.69
1	MC3159x16	36	1.27	.943	.88

Coupling

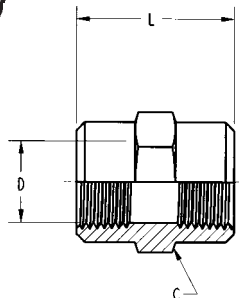
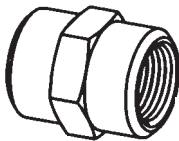

BSPT Pipe Size	Catalog Number	Hex C (mm)	L	D Dia.
1/8	MC3309x2	17	.75	.337
1/4	MC3309x4	19	1.13	.450
3/8	MC3309x6	22	1.13	.588
1/2	MC3309x8	30	1.50	.733
3/4	MC3309x12	36	1.53	.949
1	MC3309x16	41	1.89	1.192

Hex Nipple

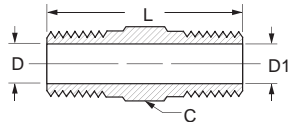
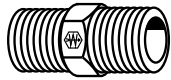

BSPT Pipe Size A	BSPT Pipe Size A1	Catalog Number	Hex C (mm)	L	T	T1	D	D1
1/8	1/8	MC3069x2x2	11	1.06	.395	.395	.188	.188
1/4	1/8	MC3069x4x2	17	1.26	.575	.395	.281	.188
1/4	1/4	MC3069x4x4	17	1.45	.575	.575	.281	.281
3/8	1/4	MC3069x6x4	19	1.45	.575	.575	.406	.281
3/8	3/8	MC3069x6x6	19	1.45	.575	.575	.406	.406
1/2	3/8	MC3069x8x6	22	1.70	.765	.575	.531	.406
1/2	1/2	MC3069x8x8	22	1.89	.765	.765	.531	.531
3/4	1/2	MC3069x12x8	30	1.99	.795	.765	.719	.531
3/4	3/4	MC3069x12x12	30	2.02	.795	.795	.719	.719
1	3/4	MC3069x16x12	36	2.18	.955	.795	.939	.719
1	1	MC3069x16x16	36	2.34	.955	.955	.939	.939
1-1/4	1	MC3069x20x16	46	2.51	1.045	.955	1.252	.939
1-1/4	1-1/4	MC3069x20x20	46	2.60	1.045	1.045	1.252	1.252
1-1/2	1-1/4	MC3069x24x20	50	2.67	1.045	1.045	1.502	1.252
1-1/2	1-1/2	MC3069x24x24	50	2.67	1.045	1.045	1.502	1.502
2	1-1/2	MC3069x32x24	65	2.98	1.205	1.045	1.940	1.502
2	2	MC3069x32x32	65	3.14	1.205	1.205	1.940	1.940

Male Connector to Male JIC 37°

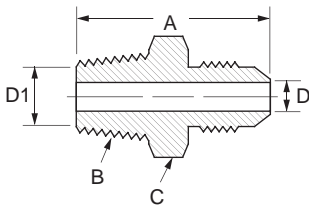
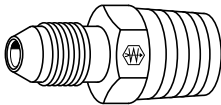

37° Tube O.D.	BSPT Pipe Size	Catalog Number	BSPT Thread B	L	Hex C	D	D1
1/4	1/8	MC5205x4x2	1/8-28	1.22	1/2	.172	.281
1/4	1/4	MC5205x4x4	1/4-19	1.42	9/16	.172	.188
1/4	3/8	MC5205x4x6	1/4-19	1.42	1/2	.172	.406
5/16	1/4	MC5205x5x4	1/4-19	1.22	9/16	.234	.281
5/16	3/8	MC5205x5x6	3/8-19	1.42	47/64	.234	.406
3/8	1/4	MC5205x6x4	1/4-19	1.21	5/8	.297	.406
3/8	3/8	MC5205x6x6	3/8-19	1.29	3/4	.297	.281
3/8	1/2	MC5205x6x8	1/2-14	1.69	55/64	.297	.531
3/8	3/4	MC5205x6x12	3/4-14	1.78	1-5/32	.297	.719
1/2	3/8	MC5205x8x6	3/8-19	1.41	13/16	.391	.531
1/2	1/2	MC5205x8x8	1/2-14	1.59	15/16	.391	.406
1/2	3/4	MC5205x8x12	3/4-14	1.88	1-5/32	.391	.719
5/8	1/2	MC5205x10x8	1/2-14	1.66	15/16	.484	.531
5/8	3/4	MC5205x10x12	3/4-14	1.99	1-1/8	.484	.719
5/8	1	MC5205x10x16	1-11	2.15	1-13/32	.484	.939
3/4	1/2	MC5205x12x8	1/2-14	2.06	1-5/32	.609	.719
3/4	3/4	MC5205x12x12	3/4-14	1.93	1-1/8	.719	.942
3/4	1	MC5205x12x16	1-11	2.25	1-13/32	.609	.531
7/8	3/4	MC5205x14x12	3/4-14	2.12	1-5/32	.609	.939
7/8	1	MC5205x14x16	1-11	2.28	1-13/32	.719	.719
1	3/4	MC5205x16x12	3/4-14	2.14	1-13/32	.845	.939
1	1	MC5205x16x16	1-11	2.13	1-3/8	.845	.719
1-1/4	1-1/4	MC5205x20x20	1-1/4-11	2.34	1-11/16	1.080	1.252
1-1/2	1-1/2	MC5205x24x24	1-1/2-11	2.71	1-15/16	1.314	1.502
2	2	MC5205x32x32	2-11	3.27	2-3/4	1.784	1.940

BSPP Male To NPTF Female Adapter

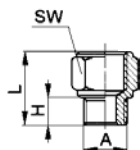

Male BSPP	Female NPTF Thread	Catalog Number	H	L	SW (mm)
1/8	1/8	1150x2x2PP	.27	.67	14
1/4	1/4	1150x4x4PP	.32	.91	17
3/8	3/8	1150x6x6PP	.35	.96	22
1/2	1/2	1150x8x8PP	.39	1.16	27

BSPF Female To NPTF Male Adapter

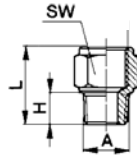

†UNF thread

Female BSPF	Male NPTF Thread	Catalog Number	H	L	SW (mm)
M5*	10-32†	1100x5MMxA	.18	.47	8
1/8	1/8	1100x2PPx2	.37	.77	14
1/4	1/4	1100x4PPx4	.51	1.06	17
3/8	3/8	1100x6PPx6	.51	1.08	19

*M5 has 0.8mm Thread Pitch. M5 seals with nylon washer, included.

Male British Standard Parallel Pipe to Male JIC 37°

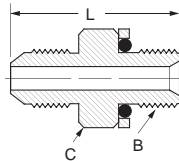
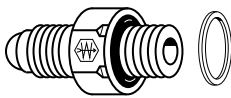

Replacement retaining rings and O-rings page 218.

Tube O.D.	BSPF Pipe Size	Catalog Number	BSPF Thread B	L	Hex C
1/4	1/8	MB5315x4x2	1/8-28	1.10	5/8
1/4	1/4	MB5315x4x4	1/4-19	1.24	3/4
5/16	1/4	MB5315x5x4	1/4-19	1.24	3/4
3/8	1/4	MB5315x6x4	1/4-19	1.25	3/4
3/8	3/8	MB5315x6x6	3/8-19	1.31	7/8
1/2	3/8	MB5315x8x6	3/8-19	1.48	7/8
1/2	1/2	MB5315x8x8	1/2-14	1.67	1-1/8
5/8	3/4	MB5315x10x12	3/4-14	1.83	1-3/8
3/4	3/4	MB5315x12x12	3/4-14	1.93	1-3/8
1	1	MB5315x16x16	1-11	2.20	1-3/4
1-1/4	1-1/4	MB5315x20x20	1-1/4-11	2.32	2

Female JIC 37° Swivel to Male British Standard Pipe Tapered BSPT Thread

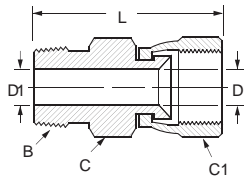
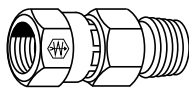

*Optional counterbore.

Tube O.D.	BSPT Pipe Size	Catalog Number	BSPT Thread B	Hex C	Hex C1	D	D1	L
1/4	1/4	M9800x4x4	1/4-19	9/16	9/16	.172	.281*	1.56
5/16	1/4	M9800x5x4	1/4-19	11/16	5/8	.234	.281*	1.63
3/8	1/4	M9800x6x4	1/4-19	11/16	11/16	.297	.281	1.69
1/2	1/4	M9800x8x4	1/4-19	7/8	7/8	.391	.281	1.87
1/2	3/8	M9800x8x6	3/8-19	7/8	7/8	.391	.406*	1.87
1/2	1/2	M9800x8x8	1/2-14	7/8	7/8	.391	.531*	2.06
5/8	1/2	M9800x10x8	1/2-14	1	1	.484	.531*	2.11
3/4	1/2	M9800x12x8	1/2-14	1-1/8	1-1/4	.609	.531	2.21
3/4	3/4	M9800x12x12	3/4-14	1-1/8	1-1/4	.609	.719*	2.24
1	3/4	M9800x16x12	3/4-14	1-3/8	1-1/2	.845	.719	2.39
1	1	M9800x16x16	1-11	1-3/8	1-1/2	.845	.938*	2.55
1-1/4	1-1/4	M9800x20x20	1-1/4-11	1-7/8	2	1.079	1.125*	2.73

Female 37° JIC Swivel to Male British Standard Pipe Parallel BSPP Thread

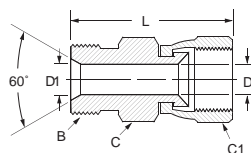
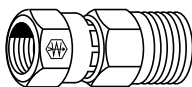

*Optional counterbore.

Tube O.D.	BSPF Pipe Size	Catalog Number	BSPF Thread B	Hex C1	Hex C	D	D1	L
1/4	1/4	M9600x4x4	1/4-19	9/16	9/16	.172	.198*	1.43
5/16	1/4	M9600x5x4	1/4-19	5/8	11/16	.234	.198	1.50
3/8	1/4	M9600x6x4	1/4-19	11/16	11/16	.297	.198	1.56
3/8	3/8	M9600x6x6	3/8-19	11/16	11/16	.297	.322*	1.66
1/2	3/8	M9600x8x6	3/8-19	7/8	7/8	.391	.322	1.77
1/2	1/2	M9600x8x8	1/2-14	7/8	7/8	.391	.448*	1.92
5/8	1/2	M9600x10x8	1/2-14	1	1	.484	.448	1.97
3/4	3/4	M9600x12x12	3/4-14	1-1/4	1-1/8	.609	.666*	2.25
1	1	M9600x16x16	1-11	1-1/2	1-3/8	.845	.885*	2.48
1-1/4	1-1/4	M9600x20x20	1-1/4-11	2	1-7/8	1.078	1.125*	2.64

**90° Elbow - Male British
Standard Pipe Tapered BSPT
to Male JIC 37°**

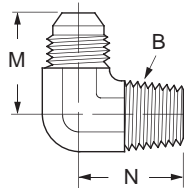
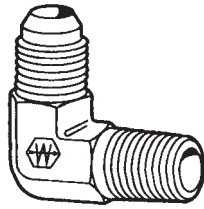

Tube O.D.	BSPT Pipe Size	Catalog Number	BSPT Thread B	M	N	Across Flats
1/4	1/4	MC5405x4x4	1/4-19	1.05	1.09	7/16
5/16	1/4	MC5405x5x4	1/4-19	1.05	1.09	1/2
3/8	1/4	MC5405x6x4	1/4-19	1.06	1.09	9/16
3/8	3/8	MC5405x6x6	3/8-19	1.14	1.22	3/4
1/2	3/8	MC5405x8x6	3/8-19	1.25	1.22	3/4
1/2	1/2	MC5405x8x8	1/2-14	1.33	1.47	7/8
5/8	3/4	MC5405x10x12	3/4-14	1.54	1.59	1-1/16
3/4	3/4	MC5405x12x12	3/4-14	1.66	1.59	1-1/16
1	1	MC5405x16x16	1-11	1.81	1.97	1-5/16
1-1/4	1-1/4	MC5405x20x20	1-1/4-11	2.06	2.38	1-5/8

**90° Elbow - Male British
Standard Pipe Parallel BSPP
to Male JIC 37°**

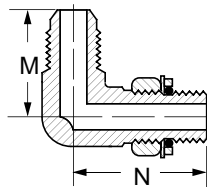
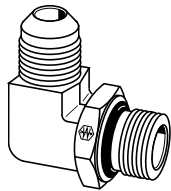

Replacement retaining rings and O-rings see below.

Tube O.D.	BSPP Pipe Size	Catalog Number	BSPP Thread	M	N	Across Flats
1/4	1/4	MB5515x4x4	1/4-19	1.05	1.25	9/16
5/16	1/4	MB5515x5x4	1/4-19	.95	1.25	9/16
3/8	1/4	MB5515x6x4	1/4-19	1.06	1.25	9/16
3/8	3/8	MB5515x6x6	3/8-19	1.14	1.45	3/4
1/2	3/8	MB5515x8x6	3/8-19	1.25	1.45	3/4
1/2	1/2	MB5515x8x8	1/2-14	1.33	1.70	7/8
5/8	3/4	MB5515x10x12	3/4-14	1.34	1.94	1-1/16
3/4	3/4	MB5515x12x12	3/4-14	1.66	1.94	1-1/16
1	1	MB5515x16x16	1-11	1.81	2.05	1-5/16
1-1/4	1-1/4	MB5515x20x20	1-1/4-11	2.06	2.25	1-5/8

British Retaining Ring

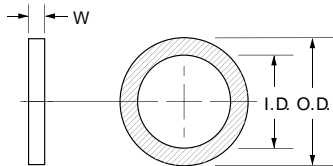

Tube O.D.	Catalog Number	Ring I.D.	Ring O.D.	W
2	MB7630x2	.45	.60	.044
4	MB7630x4	.63	.81	.067
6	MB7630x6	.77	.93	.067
8	MB7630x8	.91	1.12	.067
10	MB7630x10	1.00	1.24	.067
12	MB7630x12	1.12	1.37	.067
16	MB7630x16	1.44	1.74	.092
20	MB7630x20	1.76	2.18	.092
24	MB7630x24	2.02	2.43	.092

British O-Ring

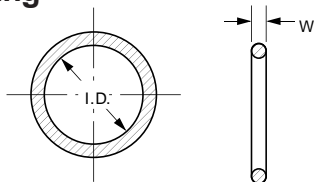

Material: Buna N 90 Durometer
Temperature Range: -40°F to +250°F
(-40°C to +121°C)

Tube O.D.	Catalog Number	W	I.D.
2	MB7629x2	.070	.239
4	MB7629x4	.103	.424
6	MB7629x6	.103	.549
8	MB7629x8	.103	.695
10	MB7629x10	.103	.818
12	MB7629x12	.103	.924
16	MB7629x16	.139	1.171
20	MB7629x20	.139	1.484

 Refer to safety information on page 1 & 2.

Coiled Air Brake Tube Assemblies



Conforms to SAE J844 Type B and SAE J1131.
 Conforms to DOT FMVSS 571.106.
 Maximum Working Pressure 150 PSI. Minimum Burst: 950 PSI.
 Temperature Range -40°F to +200°F.
 Brass end fittings with spring guards and 1/2" male pipe connections.
 Spring guards zinc plated for maximum corrosion resistance.
 Color coding, red for emergency and blue for service, provides you with error free installation.
 Preassembled for immediate installation.

Catalog Number	Tube O.D.	Male Pipe	Working Length	Pigtail Length
W1206*	1/2	1/2	12'	6"
W1212*	1/2	1/2	12'	12"
W1512*	1/2	1/2	15'	12"

*Each catalog number contains a coiled red assembly and a coiled blue assembly.

Gladhand Couplings

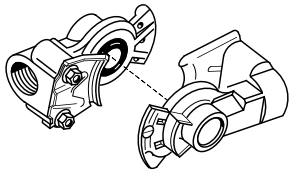

- Die cast aluminum body
- Conforms to SAE J318
- Connects to 1/2" pipe
- Includes seal

Catalog Number

- W79850 SERVICE (Signal) (Blue clip; Connects only to service)
- W79851 EMERGENCY (Supply line) (Red clip; Connects only to emergency)
- W76150 UNIVERSAL (Connects to all three styles)

Gladhand Seal

For use with W79850, W79851, W76150.



Catalog Number

W14630

 Refer to safety information on page 1 & 2.

Vernier Controls

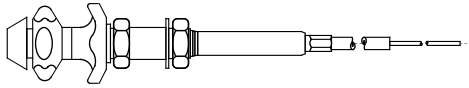

Catalog Number: 8374

New advanced styling. Meets or exceeds OEM specifications. Non-Corrosive aircraft aluminum body and stainless steel shaft assures 400 hour salt spray test without corrosion.

A direct replacement for most "Remote Throttle Controls"; Mack Truck 21QB-180 Series, Kenworth K068B Series, Peterbilt 05-1462 Series, Volvo-White 13401 Series, I.H. 34084 Series, Muncie COCL Series BPC VCG Series. Also replaces most Garage and Service Station Wreckers remote control throttles; Earnest Holmes, Dover, etc.

Turn-To-Lock Controls (T-Locking)

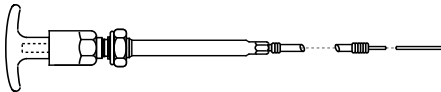

Catalog Numbers: 8370, 8371

New positive action control for small to mid-size engine throttles, governors, chokes, fuel shut-offs and more.

Aluminum body assures rust free performance. Patented Acetal Locking bushing guarantees never before possible settings with one third operator effort. Replaces Muncie COCL Series, and BPC R09 Series.

Power Take Off Controls (Ball Knob)

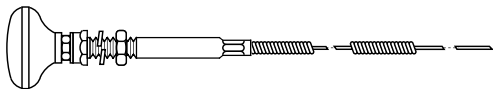

Catalog Numbers: 8372, 8373

Utility grade as exact replacement for most P.T.O. Controls.

Features 2" Round Knobs, Galvanized Steel, vinyl covered casing and steel inner wire. All P.T.O. Controls meet or exceed OEM specifications. Replaces BPC R-38DS, R04, R38 and R38D Series, Muncie COKB Series.

 Refer to safety information on page 1 & 2.

Utility Light Load Controls (Dash)

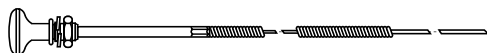

Catalog Numbers: 8375, 8376, 8377, 8378

Universal light load Choke, Fuel-Shutoff, Throttle, Hood, Trunk and more! Controls are designed for most engine applications. Stainless steel inner-wire resists corrosion and assures trouble free operation. Vinyl coated.

Throttle Stop



Catalog Number

1548

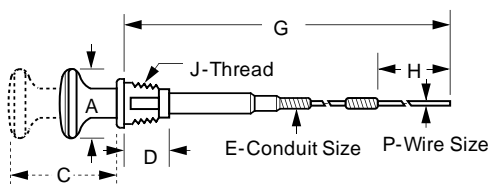

SPECIFICATION CHART ON WEATHERHEAD "PUSH-PULL" CONTROLS

Description	Dash				T-Hood	T-Locking		PTO Control		Vernier	Deluxe PTO Control	
	8375	8376	8377	8378	8367	8370	8371	8372	8373	8374	106370	106470
Catalog Number	8375	8376	8377	8378	8367	8370	8371	8372	8373	8374	106370	106470
Length of "G"	84"	84"	84"	60"	180"	126"	186"	81"	165"	120"	192"	300"
Length of Wire "H"	9-3/8"	9-3/8"	9-3/8"	7"	5"	6"	6"	3"	3"	4-1/2"	12"	12"
Knob Type	Round				T-Handle	T-Handle		Round		Round	Round	
Knob Size "A"	1.06"				2"	2"		2"		2"	2"	
Knob Color	Black				Chrome	Chrome		Black		Black	Red	
Knob Material	Plastic				Cast Zinc	Nylon		Plastic		Plastic	Plastic	
Knob Lettering	Choke	Throttle	None	None	None	Lock		None		None	None	
Knob Travel "C"	2-1/2"				2-1/2"	3"		3-1/2"		3-3/8"	4-1/2"	
Thread Size "J"	3/8"-24				3/8"-24	7/16"-20		7/16"-20		3/4"-16	1/2"-20	
Thread Length "D"	1/2"				1/2"	3/4"		1-5/32"		2-1/2"	1-1/8"	
Conduit Size "E"	3/16"				3/16"	3/16"		1/4"		1/4"	3/8"	
Conduit Material & Style	Galvanized Steel				Steel Vinyl Cover	Galvanized Steel	Galvanized Steel	Galvanized Steel	Galvanized Steel	Galvanized Steel	High Carbon	
	Vinyl	Vinyl	Vinyl	Vinyl		Vinyl Covered	Vinyl Covered	Vinyl Covered	Vinyl Covered	Polyethylene Lining & Cover		
Wire Size "P"	.054"				.054"	.054"		.088"		.0625"	.088"	

 Refer to safety information on page 1 & 2.



T-570-1 • Ermeto-Quick Set™ Preset Machine

The Ermeto-Quick Set Machine is ideal for bulk assemblies. It has a positive-stop action, which guarantees uniform repeatability, and a hand pump operation which yields quick cycle time, reducing assembly time. The T-570 is an easy tool to use that will save you time and money.

T-570 Package includes:

T-460-2	Hand Pump (10,000 PSI)		
T-450-3	Quick Disconnect Hose Assembly		
T-570-1	Ermeto® Preset Machine		
T-570-4	Preset Die	T-571-4	Tube Support
T-570-6	Preset Die	T-571-6	Tube Support
T-570-8	Preset Die	T-571-8	Tube Support
T-570-12	Preset Die	T-571-12	Tube Support
T-570-16	Preset Die	T-571-16	Tube Support

-20, -24, and -32 sizes also available.



Metric Flareless Hand Presetting Tools

Presetting tools provide a more accurate and positive leak-proof method of coupling flareless fittings. Presetting the steel metric sleeves prior to fitting assembly will permit the maximum high performance obtainable with flareless fittings. These tools are available for both the Light (DIN 3901/3902L) and Heavy (DIN 3901/3902S) flareless series.

Light Series 3901/3902L			Heavy Series 3901/3902S		
Catalog Number	Tube O.D. (mm)	Thread Size	Catalog Number	Tube O.D. (mm)	Thread Size
TL7008	8	M14x1.5	TH7008	8	M16x1.5
TL7010	10	M16x1.5	TH7010	10	M18x1.5
TL7012	12	M18x1.5	TH7012	12	M20x1.5
TL7015	15	M22x1.5	TH7014	14	M22x1.5
TL7018	18	M26x1.5	TH7016	16	M24x1.5
TL7022	22	M30x2.0	TH7020	20	M30x2.0
TL7028	28	M36x2.0	TH7025	25	M36x2.0
			TH7030	30	M42x2.0



Ermeto® Hand Presetting Tools 7000 Series

Presetting tools provide a more accurate and positive leak-proof method of coupling flareless fittings. Presetting steel Ermeto® sleeves on tubing prior to fitting assembly will permit the maximum high performance obtainable with flareless fittings. Due to possible thread galling, the use of presetting tools is required when assembling stainless steel fittings.

Catalog Number	Tube O.D. (Inches)	Thread Size	Catalog Number	Tube O.D. (Inches)	Thread Size
T-7002	1/8	5/16-24	T-7012	3/4	1-1/16-12
T-7003	3/16	3/8-24	T-7014	7/8	1-3/16-12
T-7004	1/4	7/16-20	T-7016	1	1-5/16-12
T-7005	5/16	1/2-20	T-7020	1-1/4	1-5/8-12
T-7006	3/8	9/16-18	T-7024	1-1/2	1-7/8-12
T-7008	1/2	3/4-16	T-7032	2	2-1/2-12
T-7010	5/8	7/8-14			

 Refer to safety information on page 1 & 2.

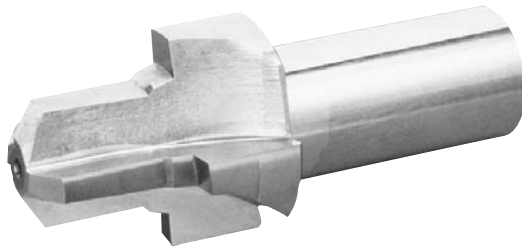

SAE Straight Thread O-Ring Boss Tapping and Counterboring Tools

These Weatherhead precision counterborer and tap tools are available in the full range of sizes. They provide the correct SAE contour and UNF-2B threads for proper containment of Weatherhead Flareless '7000' Series Ermeto® and Weatherhead Flare-Twin® straight-thread o-ring tube fittings.

Thread Tap Catalog No.	UNF-2B Thread Size of Thread Tap	Drill Size	For Fitting Size	For Tube O.D.	Counter-Borer Catalog No.
T-5002	5/16-24	I	2	1/8	T-5102
T-5003	3/8-24	O	3	3/16	T-5103
T-5004	7/16-20	W	4	1/4	T-5104
T-5005	1/2-20	29/64	5	5/16	T-5105
T-5006	9/16-18	1/2	6	3/8	T-5106
T-5008	3/4-16	11/16	8	1/2	T-5108
T-5010	7/8-14	51/64	10	5/8	T-5110
T-5012	1-1/16-12	31/32	12	3/4	T-5112
T-5014	1-3/16-12	1-3/32	14	7/8	T-5114
T-5016	1-5/16-12	1-7/32	16	1	T-5116
T-5020	1-5/8-12	1-17/32	20	1 1/4	T-5120
T-5024	1-7/8-12	1-25/32	24	1 1/2	T-5124
T-5032*	2-1/2-12	2-27/64	32	2	T-5132*

*Special order only.



RG-24 • Hydraulic O-Ring Assortment

Weatherhead's RG-24 is your solution to storing a useful inventory of hydraulic o-rings. This kit contains o-rings for Weatherhead's straight thread and FOR-SEAL® tube fitting applications as well as popular (code 61) split flange hydraulic applications. The RG-24 comes enclosed in a handy steel case with a carrying handle. Consider an RG-24 for an over-the-counter sales merchandiser or keep one in your equipment shop or maintenance trailer to prepare for those critical "got-to-have-it" applications.

Twenty-four individual compartments keep your hydraulic o-ring inventory separated by part number, and labelled illustrations on the inside of the assortment prevent the mix-up of o-rings. Compact, organized and reasonably priced, if you specialize in hydraulic applications which call for o-rings – we've got your number – RG-24.

RG-24 • O-Ring Assortment Contents

Part Number	Split Flange Quantity	Part Number	FOR-SEAL® Quantity	Part Number	Straight Thr. Quantity
8x252	12	4629x4	12	7629x4	12
12x252	12	4629x6	12	7629x5	12
16x252	12	4629x8	12	7629x6	12
20x252	12	4629x10	12	7629x8	12
24x252	12	4629x12	12	7629x10	12
32x252	12	4629x16	12	7629x12	12
		4629x20	12	7629x16	12
		4629x24	12	7629x20	12
				7629x24	12
				7629x32	12

O-rings conform to SAE J515 Type CH.

 Refer to safety information on page 1 & 2.



TA-1002 • Thread Measuring Kit

Measuring tube and pipe fitting threads can be a most difficult task if not completely understood. Tools needed include a thread pitch gauge, calipers and seat angle gauges. To aid you, Weatherhead has a kit to fit your needs, the TA-1002 thread measuring kit.

This handy kit includes:

- Thread Pitch Gauge (American and metric)
- Inside/Outside Caliper (inches and millimeters)
- 2 Seat Angle Gauges (37°/45° and a 12°/30°)
- 24-Page International Measuring and Identification Guide and Instruction Booklet
- Carrying Case for Easy and Convenient Storage



TA-1004 • Metric Thread Identification Kit

Contained in a durable steel carrying case, TA-1004 will help you with identification of metric, British pipe and JIS thread configurations. Identification pieces are configured for 20 metric and 8 British pipe sizes, an increase of three metric sizes compared to the TA-1003.

This handy kit includes:

- Steel Carrying Case
- Stainless Steel Caliper
- Metric and British Thread Pitch Gauges
- British Thread Measuring Templates (4 measuring 8 sizes) made of durable aircraft grade aluminum.
- Metric Thread Measuring Templates (10 measuring 20 sizes) made of durable aircraft grade aluminum.
- Kit Content Identification Chart

 Refer to safety information on page 1 & 2.



Rapid Wrenches

The Rapid Wrench is a heavy-duty, high quality wrench that ratchets for quick installation and removal of tube fittings and hose ends. These wrenches have jaws that snap open and close completely around the fitting giving 6-point contact. Needing only 30° of rotation to ratchet, they allow easy access to tight locations. Available individually or in a set with pouch, these wrenches are a welcome addition to any tool box.

- T-139** 7-Piece Set with Pouch (1/2" through 7/8")
- T-139P** Pouch for 7-Piece Set
- T-152** 11-Piece Set with Pouch
- T-152P** Pouch for 11-Piece Set

Catalog Number	Wrench Hex Size	Catalog Number	Wrench Hex Size
T-140	3/8"	T-145	11/16"
T-141	7/16"	T-146	3/4"
T-142	1/2"	T-147	13/16"
T-143	9/16"	T-148	7/8"
T-144	5/8"	T-149	15/16"
		T-151	1"



T-150 • Utility Tube Cutter

Need to cut stainless steel tubing? This cutting tool is for you. It features an enclosed feed screw to eliminate clogging and jamming. Grooved rolls for close to flare cuts and a fold away reamer.

Capacity: 1/8" to 1-1/8" O.D. Cuts hard and soft copper, aluminum, brass, carbon steel and stainless steel tubing.

Spare Parts: **T-1422R** Replacement Cutting Wheel

 **CAUTION:** Sharp blade! Keep hands and fingers away from cutting surface!



T-1430 • Inner-Outer Reamer

Reams both inside and outside edges of tube with three hollow ground tool steel cutters. Fluted body is shaped to fit comfortably in palm of hand.

Capacity: 3/16" to 1-1/2" O.D. Reams copper, brass, aluminum and other tubing.

 **CAUTION:** Sharp blade! Keep hands and fingers away from cutting surface!

 Refer to safety information on page 1 & 2.



T-1037 • Knife

An inexpensive, reliable knife useful in splitting twin-line hoses quickly and easily.

Replacement Blade: [T-1037B](#)

Replacement Handle: [T-1037H](#)



T-135 • Plastic Tube and Hose Cutter

An economical alternative to quality tube and hose cutting. This versatile tool is lightweight and durable for long service life.

Replacement Blade: [T-135B](#)

Replacement Blade for T-125: [T-125B](#)

Capacity: Up to 1" hose I.D.

NOTE: Not for use with wire-reinforced hose.



T-138 • Hose and Tube Cutter

One hand operation for quick, clean cuts through plastic or nylon compound tubing and solid or fiber-reinforced hose up to 1-1/2" O.D.

- Any wireless hose or tubing.
- Power steering hose (H324)
- Air Conditioning hose (H757)
- Air brake hose (H338)
- Air system nylon tubing (NT100)
- Thermoplastic hose (H435, H436, H335, and H336)
- Low pressure plastic tubing (PT200, PT230, PT240)

Replacement Blade: [T-138B](#)

NOTE: Not for use with wire-reinforced hose.



T-191 • Plastic Tube and Hose Cutter

A tool designed to be small, only 2-7/8" long. The versatile Weatherhead T-191 offers quick and clean square cuts on 1/16" to 1/2" O.D. plastic tubing and non-wire reinforced hose. The T-191 can be either bench or wall mounted and offers the safety of closing automatically when not in use.

Spare Parts: [T-191B](#) Replacement Blade (one per package)

 Refer to safety information on page 1 & 2.

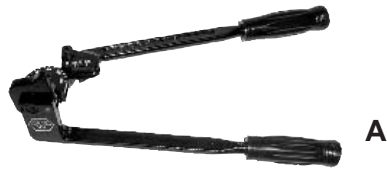

A



B



C

LEVER TYPE TUBE BENDERS

Each tool bends one size. Openside type. Handy in a tight spot. Makes precision short radius bends up to 180° with minimum effort. Keeps tube round, no marks or scrapes, shows bend degree. Unique extra strong hook grips tubing securely.

Catalog Number	Tubing (O.D.)	Nominal Size	Radius to Center of Tube	Weight Each	Type
T-372	1/8	—	3/8	8 ozs.	A
T-373	3/16	—	7/16	9 ozs.	A
T-374	1/4	1/8	9/16	12 ozs.	B
T-375	5/16	—	11/16	1 lb. 4 ozs.	B
T-376	3/8	—	15/16	1 lb. 12 ozs.	B
T-378	1/2	3/8	1-1/2	3 lb. 8 ozs.	B
T-3710*	5/8	1/2	2-1/4	10 lbs.	C
T-3712*	3/4	5/8	3	10 lbs. 8 ozs.	C
T-3716*	1	—	3-1/2	10 lbs. 8 ozs.	C

* Will bend annealed copper and aluminum tubing only.

Capacity: Individual tools for bending eight sizes from 1/8" to 3/4" O.D. tubing. Will bend annealed copper, annealed-steel (inc. JIC), stainless steel and all soft tubing.

SPRING TUBE BENDERS

Low cost, tube bending spring operates perfectly in hand bending copper, aluminum and other thin-walled tubing. Bends are true with minimum tubewall collapsing. Belled at one end to facilitate removal. Bright-plated spring wire finish.



Catalog Number	Tubing (O.D.) (Inches)	Length (Inches)	Weight
T-104	1/4	10	4 ozs.
T-105	5/16	10	4 ozs.
T-106	3/8	10	5 ozs.
T-107	7/16	12	7 ozs.
T-108	1/2	12	8 ozs.
T-1010	5/8	12	10 ozs.
SETS			
T-100	1/4, 3/8, 1/2, 5/8	10 & 12	1-1/2 lbs.
T-200	1/4, 5/16, 3/8, 1/2	10 & 12	1-1/4 lbs.

Refer to safety information on page 1 & 2.



T-345K • Tube Cutting and Flaring Kit

Tube flaring and cutting has just become a little easier with the convenient T-345K Tube Flaring and Cutting Kit.

This kit features a quality-made Double Flaring Tool offering accurate single flares between 3/16" and 5/8" O.D. tubing. Double flares between 3/16" and 2/2" O.D. tubing. Check these features:

- Hardened, smooth cone for fast, accurate 45° flares.
- Single and double flare capability.
- Clamp screw for easy clamping and removal of tubes.
- Flaring Bar installed from either side of yoke.
- Flares soft copper, brass, aluminum and mild steel (JIC and Bundy) tubing.

T-345K Components can be ordered separately:

T-345 45° Flaring Tool, Double Flare Adapters and Plastic Box

T-150 1/8" to 1-1/8" Tube Cutter

T-1422R T-150 Spare Cutting Wheel

Double Flare Adapters:

Catalog Number	Tube O.D.
T-346x3	3/16"
T-346x4	1/4"
T-346x5	5/16"
T-346x6	3/8"
T-346x8	1/2"

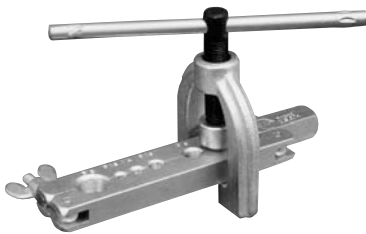

T-1022 • Flaring Tool (45°)

Economical, fast operating tool. Quick slip-on aluminum alloy yoke. Easy operating, swivel-type, hard chrome finished cone assures smooth flares.

Yoke slips down over top of bar and locks into position with a single turn.

Flaring Capacity: 3/16", 1/4", 5/16", 3/8", 7/16", 1/2", and 5/8" O.D. Forms 45° flares in soft copper, aluminum and brass.

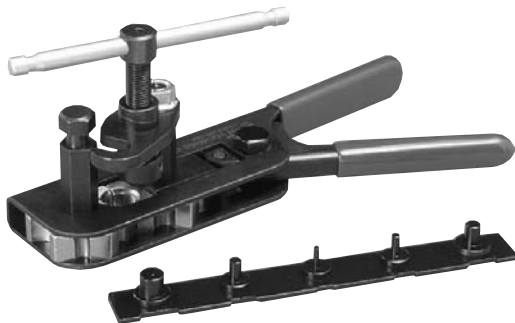

T-220 • Double Flaring Tool (45°)

This new style tool makes single or double flaring easier and quicker than ever. Cam action provides positive, non-slip grip on the tubing with just a squeeze of the handle. Double flaring bar also serves as gauge for correct tubing height to insure perfect flares.

Flaring Capacity: 3/16", 1/4", 5/16", 3/8", 1/2" and 5/8" O.D. for single flares, and up to 1/2" O.D. for double flares. Can be used with copper, aluminum, brass, bundyweld and steel tubing.

Weight: 2 lbs.

T-220 Components can be ordered separately

T-210 Tool for single flaring only

T-221 Double Flaring Bar only.

Flaring Capacity: 3/16", 1/4", 5/16", 3/8" and 1/2"



T-1290 • Segmented Flaring Tool (37°)

Hard chrome finished cone makes exceptionally smooth flares and minimizes amount of effort needed. Forged steel yoke for maximum strength. Sliding die blocks lock in place by lever clamp action.

Flaring Capacity: 3/16", 1/4", 5/16", 3/8", 1/2" and 5/8" O.D. Forms 37° SAE flares in soft copper, aluminum, brass and bundyweld tubing.

Weight: 1 lb., 11 oz.

 Refer to safety information on page 1 & 2.

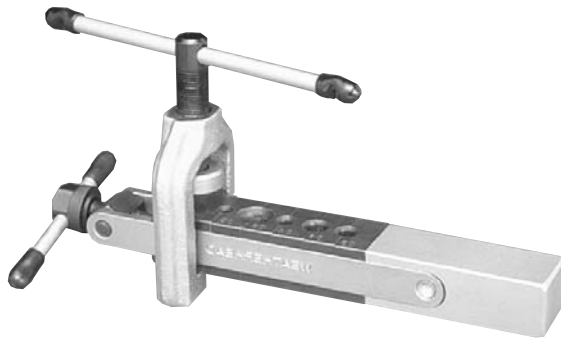

T-1295 • Heavy-Duty Segmented Flaring Tool (37°)

Ideal for use where considerable number of 37° flares in stainless steel tubing must be made. Built to withstand continuous rugged service. Ball thrust mechanism reduces effort required. Hardened tool steel die features non-slip grip of tubing – even after repetitive flaring. Bar has vise extension.

Flaring Capacity: 1/8", 3/16", 1/4", 5/16", 3/8", and 1/2", O.D. tubing. Forms 37° SAE flares in annealed stainless steel (MIL-T-6845 or AMS-5566), cold drawn stainless steel, and annealed copper, brass, steel or aluminum.

Weight: 3 lbs.



T-562 • Circa Torch

This braze tool from Weatherhead provides an excellent way to braze FOR-SEAL® fittings. Heat is evenly distributed among six flame ports creating a fast, convenient way to make tube assemblies.

 **WARNING:** Torch only to be used with acetylene!

 **WARNING:** Must be used in a well ventilated area!

 Refer to safety information on page 1 & 2.



 **WARNING:** Must be used in a well ventilated area!

T-560 • MAGNATORCH BRAZING MACHINE

The new Magnatorch Brazing Machine from Weatherhead is perfect for making large numbers of FOR-SEAL® Tube Fitting Assemblies. By providing 360 degree induction heating, the brazing process is fast, clean and flameless. A heavy duty cart is also provided with table top work area, vise, and storage drawer to make up a complete brazing station. The T-560 includes one each of the following:

Catalog Number	Qty.	Description
T-560-1	1	Magnatorch Power Source
T-560-2	1	Magnatorch Water System
T-560-3	1	Magnatorch Induction Torch
T-560-4	1	Magnatorch Power Cables
T-560-5	1	Magnatorch Heating Coil #1 (1-1/4 I.D.)
T-560-6	1	Magnatorch Heating Coil #2 (1-5/16 I.D.)
T-560-7	1	Magnatorch Heating Coil #3 (2-1/4 I.D.)
T-560-8	1	Magnatorch Torch Cart

LABEL SETS

for FC-16X, C-63X and C-632X Cabinets

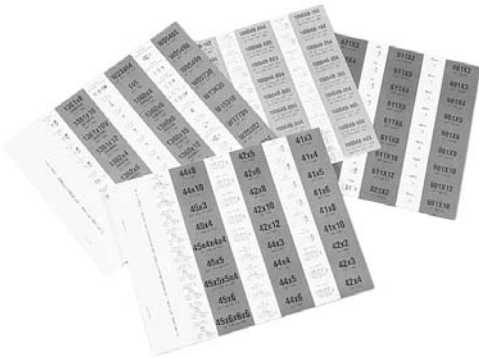

Full assortment available. Each label contains catalog number, illustration, size data and color coding for quick, positive identification of parts. Labels slide easily into slots on drawers and dividers.

Catalog Number	Description
CL-16-1	Standard Brass Fittings for FC-16X cabinet.
CL-16-2	Air brake fittings for copper tubing. Use with FC-16X cabinet.
CL-16-3	Air brake fittings for nylon tubing. Use with FC-16X cabinet.
CL-434	Fuel Line Hose Fittings (series 057B).
CL-490	Standard brass fittings, drain and shut-off cocks includes Compression, SAE, Inverted and Pipe, and series 057B line hose fittings.
CL-491	Air brake fittings for copper tubing.
CL-492	Hydraulic brake fittings.
CL-493	Barb-Tite® hose ends.
CL-494	Master Set - contains one each of CL-490, CL-491, CL-492, CL-493.
CL-496	Mini-Barb® fittings.
CL-497	Air brake fittings for nylon tubing.
CL-498	Polyline® fittings.
CL-499	Push>Connect
CL-500	Selfalign®
CL-501	Plastic Fittings
CL-502	Metric Adapters
CL-503	QCAB® Fittings

SELF-ADHESIVE LABEL SETS

for FH-15X and C-15X Cabinets



Labels are printed on self-adhesive stock for quick application. Each label contains an illustration of the part along with the catalog number and size information.

Catalog Number	Description
FS-100	Swivel Adapters
FS-200	JIC 37° Flare Twin Steel Adapters
FS-300	Split Flange Adapters, Split Flange Kits, O-Ring Port Adapters
FS-500	Barb-Tite® Hose Ends
FS-501	BL-456 Assortment Label Set
FS-800	Air brake fitting for copper tubing and 338 "B" Series Hose Ends
FS-900	Air brake fittings for nylon tubing
FS-1000	Mini-Barb® fittings
FS-1600	Flareless Ermeto® 7000 Series
FS-2000	Steel pipe fittings
FS-2100	Polyline® fittings
FS-2400	FOR-SEAL® Adapters
FS-3300	QCAB® Fittings
SH-53	Weatherhead envelope 6" x 4-1/2" (Qty 500)
W-8022	Standard brass fittings and drain-shut-off valves

PLASTIC BAGS



Weatherhead heavy-duty plastic bags for Weatherhead fittings come in sizes 5"x6", 6"x10", and 8"x12". The bags include convenient spaces for labeling.

Catalog Number	Description	Qty.
5x6 PB	Plastic Bag	100
6x10 PB	Plastic Bag	100
8x12 PB	Plastic Bag	100



FC-16X • STOCK CABINET

Contains 16 clear plastic drawers that can be divided into two or three sections. Illustrated color labels are available to provide instant identification of drawer contents.

Size: 16-1/8" wide x 11-3/4" high x 9" deep
Weight: 13 lbs.
Individual Drawers: PD-49
Dividers: PD-75 set (14/set)



C-15X • STOCK CABINET

Contains 15 extra large white drawers for those large, difficult to store fittings and valves. The 15 drawers may be divided into two or three sections to suit your particular needs.

Size: 30-1/4" Wide x 14-3/8" Deep x 13-5/8" High
Weight: 45 lbs.
Individual Drawers: CD-15
Dividers: CD-15D (30 per set)



FH-15X • STOCK CABINET

Here is the ideal way to organize your inventory of hose ends and adapters. Stock it anyway you want — to fit your particular needs. It can be used for field service, or as a jobber display and stock cabinet. The rugged FH-15X cabinet contains 15 plastic drawers for stocking hose ends and adapters.

Size: 30-1/4" Wide x 13-5/8" High x 14-3/8" Deep
Weight: 45 lbs.
Individual Drawers: PD-95
Dividers: PD-15 (30 per set)



C-63X • STOCK CABINET

A cabinet containing 63 drawers that can be divided into two or three sections. The bright color and attractive design make the C-63X stock cabinet a nice addition to any store front.

Used with assortments: AB-1400, CA-631, and CA-632.

Size: 30-1/4" wide x 25" high x 9-1/4" deep
Weight: 61 lbs.
Individual Drawers: PD-49
Dividers: PD-75 Set (14/set)



C-632X • Cabinet

This Weatherhead Brass Fittings Cabinet, C-632X, is a space saving, efficient, easy to use addition to the modern store with lobby type sales area. The C-632X requires a minimum of space but does a maximum job merchandising the wide variety of fittings in the 126 clear, wide, plastic drawers. An additional 15 large, high impact plastic drawers located in the bottom section provide ample space for those large or heavy special fittings you may be stocking.

Restocking is easy when you start at the bottom and pull drawers for an order check. Leave drawers extended that are low in stock. Now start at top, note quantity needed and return drawers to original position after order is written using standard box quantities listed on labels. Plastic dividers are provided to section drawers for future expansion when new or additional part numbers are needed.

Display this attractive cabinet with a recommended stock of fittings in your lobby and watch your brass fitting sales increase as the C-632X silently and quickly services your customers. Create those impulse sales that make your business and profits grow!

For complete **CA-632** assortment, see page 233.

CONTENTS

Catalog Number	Description
C-15X	15 Drawer Cabinet
C-63X	63 Drawer Cabinet
CB-63X	Cabinet Base
CD-15	Plastic Drawer for C-15X
C-632X	2—C-63X, 1—C-15X, 1—CB-63X
PD-49	Drawers for C-63X
PD-75 set	Dividers for drawers (14 count)

Size: 68-1/2" high, 30" wide, 15" deep.

Weight: 167 lbs.

CA-632 • FITTINGS ASSORTMENT

The CA-632 assortment combines a colorful, attractive lobby display unit and an assortment of fast moving brass fittings with coverage for most any application. This space saving assortment includes color coded, illustrated, labels for quick identification by customers of standard fittings, as well as fuel line, carburetion, metric and domestic hydraulic brake and thermoplastic brass fittings in 240 configurations and sizes. Be a supplier to auto dealers, brake specialists, RV shops, plant maintenance shops, truck and bus fleets, contractors, marinas, loggers, shipyards, fishing fleets, farmers and self installers for their brass fitting requirements. Contents of this assortment may vary as new fittings are introduced and stock fittings change in popularity.

Contents Only: [CA-632CO](#)

CA-632 Contents

Catalog Number	Quantity	Catalog Number	Quantity	Catalog Number	Quantity	Catalog Number	Quantity
05703B-102	5	302x5	10	3600x2	5	62x10	1
05704B-102	10	302x6	5	3600x4	5	6200x2	10
05704B-104	5	3129x2	5	3700x2	10	6200x3	10
05704B-C02	5	3150x2	10	3700x4	5	6200x4	10
05705B-102	10	3150x4	10	3700x6	5	6202	10
05705B-104	5	3151x2	10	3750x2	5	64x4	5
05705B-C02	10	3151x4	10	3750x4	5	64x6	5
05705B-C04	10	3151x6	10	402x3	10	66x2	10
05705B-1560	10	3151x8	5	402x4	10	66x3	10
05705B-1561	10	3152x2	10	402x4x4	5	66x4	10
05706B-102	10	3152x4	10	402x5	10	66x6	5
05706B-104	10	3152x6	10	402x5x4	10	6660	5
05706B-106	5	3152x8	5	402x6	10	6749	1
05706B-C02	5	3152x12	2	41x3	10	68x2	10
05706B-C04	5	3200x2	10	41x4	10	68x3	10
05706B-1568	5	3200x4	5	41x5	10	68x4	10
05706B-1570	5	3200x4x2	10	41x6	10	68x4x4	10
100x3	10	3200x6x4	5	41x8	5	68x5	10
100x4	10	3200x8x6	5	42x4	5	68x5x4	10
100x5	10	3220x4x2	20	42x6	5	68x6	10
100x6	10	3220x6x2	10	48x3	10	68x6x2	10
105x2	10	3220x6x4	10	48x4	10	68x6x6	5
105x3	20	3220x8x2	5	48x4x4	10	68x8	5
105x4	20	3220x8x4	10	48x5	10	6809	5
105x5	20	3220x8x6	5	48x5x4	10	6829	5
105x6	10	3220x12x6	2	48x6	10	6892	5
131x3	10	3220x12x8	2	48x6x2	5	69x2	10
131x4	10	3300x2	10	48x6x6	5	69x3	10
131x5	10	3300x4	10	48x8	5	69x4	10
131x6	10	3300x4x2	10	49x4	10	69x4x4	10
135	10	3300x6	5	49x4x4	5	69x5	10
140	5	3300x6x4	5	49x5	10	69x5x4	10
1442	5	3300x8	5	49x5x4	5	69x6	10
1443	5	3300x8x6	5	49x6	10	69x6x2	5
145	10	3325x2	10	49x8	5	69x6x6	5
1514	5	3325x4	10	60x2	50	69x8	5
1538	10	3325x4x2	5	60x3	50	7818	5
1548	10	3325x6	5	60x4	50	7828	5
1539	10	3325x6x4	5	60x5	50	7829	5
1540	10	3326x2	10	60x6	50	7896x3	5
202x3	10	3326x4	10	60x8	20	7896x4	5
202x4	10	3326x6	10	60x10	10	7904	5
202x4x4	10	3326x8	5	61x2	10	7906	5
202x5	10	3327x2	10	61x3	20	7908	2
202x5x4	10	3327x4	5	61x4	20	7914	2
202x6	10	3328x2	10	61x5	20	7934A	5
202x6x2	5	3328x4	5	61x6	10	7935	5
2030x4	10	3328x6	5	61x8	10	7936	5
2030x44	10	3350x2	5	6100x2	10	7937	5
2030x5	10	3350x4	5	6100x3	10	7940	5
2030x6	10	3350x6	5	6100x4	10	7941	5
2030x8	5	3400x2	10	62x2	10	C-632X	1
252x3	10	3400x4	10	62x3	10	CL-490	1
252x4	10	3400x6	5	62x4	10		
270	5	3400x8	5	62x5	10		
302x3	10	3500x2	10	62x6	10		
302x4	10	3500x4	10	62x8	5		

RELATED
PROD



CA-631 • BRASS FITTINGS ASSORTMENT

This merchandiser will help you organize your brass fittings in an attractive 63 drawer cabinet. It includes a stock of the 100 fastest moving brass fittings to better service your customers. To expand, divide the clear, easy to inventory, super sized plastic drawers in half or thirds with plastic dividers provided. Illustrated, color-coded labels in a wide range of fitting types provide instant identification of drawer contents. Your lobby and sales will be improved with this modern display set up on a gondola or shelf. Contents may vary as new numbers become available and popularity changes.

Contents Only: [CA-631CO](#)
Cabinet Only: [C-63X](#)

CA-631 Contents

Catalog Number	Qty.	Catalog Number	Qty.	Catalog Number	Qty.	Catalog Number	Qty.	Catalog Number	Qty.	Catalog Number	Qty.
105x3	20	302x4	10	3200x4x2	10	3326x6	10	48x4x4	10	62x2	10
105x4	20	302x5	10	3200x6x4	5	3327x2	5	48x5	10	62x3	10
105x5	20	302x6	5	3220x4x2	20	3327x4	5	48x5x4	10	62x4	10
105x6	10	402x4	10	3220x6x2	10	3328x2	5	48x6	10	62x5	10
131x3	10	402x5	10	3220x6x4	10	3328x4	5	48x6x6	5	62x6	10
131x4	10	402x6	10	3220x8x2	5	3350x2	5	49x4	5	68x2	10
131x5	10	3150x2	5	3220x8x4	10	3350x4	5	49x6	10	68x3	10
131x6	10	3150x4	5	3220x8x6	5	3400x2	10	60x2	50	68x4	10
135	10	3151x2	10	3300x2	10	3400x4	10	60x3	50	68x4x4	10
145	10	3151x4	10	3300x4	10	3400x6	5	60x4	50	68x5	10
202x3	10	3151x6	10	3300x4x2	10	3700x2	10	60x5	50	68x5x4	10
202x4	10	3151x8	10	3300x6	5	3700x4	5	60x6	50	68x6	10
202x4x4	10	3152x2	10	3300x6x4	5	3750x4	5	61x2	10	68x6x2	10
202x5	10	3152x4	10	3325x2	10	3750x6	2	61x3	10	69x4	10
202x5x4	10	3152x6	10	3325x4	10	41x4	10	61x4	10	69x6	10
202x6	5	3152x8	5	3326x2	10	41x6	10	61x5	10	C-63X	1
302x3	10	3200x2	5	3326x4	10	48x4	10	61x6	10	CL-490	1



FC-161 • BRASS FITTINGS ASSORTMENT

The FC-161 brass fitting assortment contains the fastest moving SAE 45° Flare, Inverted Flare, Compression and Pipe catalog numbers to give your customers maximum coverage at a low cost. Nuts, sleeves and unions make an ideal stock for any small repair, auto, boat, lawn mower, or fixit shop. Cabinet includes 16 clear plastic drawers and color-coded labels for easy identification. The FC-161 fits on any shelf and goes to work immediately.

Cabinet Only: [FC-16X](#)

FC-161 Contents

Catalog Number	Qty.	Catalog Number	Qty.	Catalog Number	Qty.	Catalog Number	Qty.	Catalog Number	Qty.	Catalog Number	Qty.
105x3	10	302x5	2	402x3	2	48x6	2	61x3	10	68x4	2
105x4	10	3151x2	2	402x4	2	49x4	2	61x4	10	68x5	2
105x5	10	3151x4	2	402x5	2	49x5	2	61x5	10	68x6	2
105x6	5	3220x4x2	5	41x4	2	49x6	2	61x6	5	69x4	2
145	5	3220x6x4	5	41x5	2	60x3	20	62x3	5	69x5	2
202x4	2	3300x2	5	41x6	2	60x4	20	62x4	5	69x6	2
202x5	2	3300x4	2	48x4	2	60x5	20	62x5	5	CL-16-1	1
302x3	5	3400x2	5	48x5	2	60x6	20	62x6	5	FC-16X	1
302x4	5	3400x4	5								



SS-85 • STANDARD BRASS FITTINGS ASSORTMENT

Instant service for service stations, car dealers, repair shops. Contains 85 of the fastest moving Weatherhead brass fittings.

Compact, lightweight plastic box stores easily in a drawer, shelf or service truck. Saves you time and money by having the right fitting when it is needed. Eliminates searching and make-shift repairs by giving you the right part when you need it most.

SIZE: 11" wide, 1-3/4" high, 6-3/4" deep. **WEIGHT:** 3-1/4 lbs.

Catalog Number	Qty.	Catalog Number	Qty.	Catalog Number	Qty.
105x3	5	3300x2	5	62x3	2
105x4	5	402x4	2	62x4	5
105x5	10	60x3	5	62x5	5
202x4	5	60x4	10	62x6	2
202x5	5	60x5	5	68x4	2
3151x2	2	60x6	5	BF-40X	1
3220x4x2	5				



SS-86 • COMPRESSION FITTINGS ASSORTMENT

Assortment contains 80 of the fastest moving compression fittings.

SIZE: 11" wide, 1-3/4" high, 6-3/4" deep. **WEIGHT:** 3-1/2 lbs.

Catalog Number	Qty.	Catalog Number	Qty.	Catalog Number	Qty.
60x3	5	61x5	5	68x3	2
60x4	10	61x6	5	68x4	5
60x5	5	62x3	5	68x5	2
60x6	5	62x4	5	69x3	2
61x3	5	62x5	5	69x4	5
61x4	5	62x6	2	69x5	2
				BF-40X	1



SS-87 • INVERTED FLARE ASSORTMENT

Assortment contains 84 of the fastest moving inverted fittings.

SIZE: 11" wide, 1-3/4" high, 6-3/4" deep. **WEIGHT:** 3-1/2 lbs.

Catalog Number	Qty.	Catalog Number	Qty.	Catalog Number	Qty.
105x3	5	202x5	5	402x3	5
105x4	5	202x6	2	402x4	5
105x5	5	302x3	5	402x5	5
105x6	5	302x4	5	402x6	5
202x3	5	302x5	5	7896x3	5
202x4	5	302x6	2	7896x4	5
				BF-40X	1



SS-88 • BRASS PIPE ASSORTMENT

Assortment contains 59 of the fastest moving brass pipe fittings.

SIZE: 11" wide, 1-3/4" high, 6-3/4" deep. **WEIGHT:** 3-1/2 lbs.

Catalog Number	Qty.	Catalog Number	Qty.	Catalog Number	Qty.
3152x2	5	3326x2	5	3400x2	5
3152x4	5	3326x4	5	3400x4	2
3152x6	2	3326x6	2	3400x6	2
3220x4x2	2	3350x2	5	3500x2	2
3220x6x4	2	3350x4	4	3500x4	2
3300x2	5	3350x6	2	BF-40X	1
3300x4	2				



BF-40 • HYDRAULIC BRAKE FITTINGS ASSORTMENT

The BF-40 assortment of fast moving hydraulic brake fittings is a must for any shop doing brake service work. Contains the adapters needed to convert large size ports in master cylinders to accept standard steel brake lines plus the brass tees used in the installation of electric towed trailer brakes.

Assortment is organized in a compact, handy plastic box for easy selection.

SIZE: 11" wide, 1-3/4" high, 6-3/4" deep. **WEIGHT:** 4 lbs. (approx.)

Catalog Number	Qty.	Catalog Number	Qty.	Catalog Number	Qty.
7818	2	7901	2	7911	2
7828	2	7904	2	7912	2
7829	2	7905	2	7913	2
7897	2	7906	2	7914	2
7898	2	7908	2	7917	2
7900	2	7910	2	7933	2
				BF-40X	1



BF-41 • HYDRAULIC BRAKE LINE ADAPTER ASSORTMENT

The BF-41 assortment contains the adapters needed to convert the oversize master cylinder ports to accept the inverted flare nut used on standard replacement steel brake lines. The adapters eliminate the need to cut line, install oversize nut and double flare tubing as well as converting the port to standard size threads for the life of the car. Extra standard nuts and the unions needed to connect two steel brake lines when a non-standard length is required are also included in the assortment. The contents including the illustrations of parts are shown on the inside cover of the box.

SIZE: 11" wide, 1-3/4" high, 6-3/4" deep. **WEIGHT:** 4 lbs. (approx.)

Catalog Number	Qty.	Catalog Number	Qty.	Catalog Number	Qty.
105x3	10	302x4	5	7896x3	5
105x4	10	302x5	5	7896x4	5
105x5	10	302x6	2	7897	2
105x6	5	7818	2	7908	2
105x6x7	2	7828	2	7917	2
302x3	5	7829	2	BF-40X	1



BF-42 • RV BRAKE LINE ADAPTER ASSORTMENT

The BF-42 assortment contains the adapter tees required to install the control switch used to coordinate the electric trailer brakes with the hydraulic brakes on towing vehicle. The assortment also contains inverted brake line nuts and unions needed to make up non-standard steel brake line lengths.

SIZE: 11" wide, 1-3/4" high, 6-3/4" deep. **WEIGHT:** 4 lbs.

Catalog Number	Qty.	Catalog Number	Qty.	Catalog Number	Qty.
105x3	10	302x5	5	7906	1
105x4	10	7898	1	7914	1
105x5	10	7900	1	7921	1
105x6	5	7901	1	7933	1
105x6x7	2	7904	1	BF-40X	1
302x3	5	7905	1		
302x4	5				



BF-43 • METRIC BRAKE ADAPTER AND TEE ASSORTMENT

The BF-43 assortment contains metric thread connectors to adapt the three port sizes in late model GM cars to use a steel brake line with metric threads (M10x1.0) and standard flare (Weatherhead J series). Included as well are metric adapters to convert European Bubble flare type ports to accept standard 3/16" U.S. steel brake lines, and metric towed trailer brake tees used in controls of electric trailer brakes. The 3/16" unions are used for joining metric and U.S. steel brake lines to make up non-standard lengths.

SIZE: 11" wide, 1-3/4" high, 6-3/4" deep.

Catalog Number	Qty.	Catalog Number	Qty.	Catalog Number	Qty.
105x3	10	7935	1	7974	1
105x4	5	7936	1	7975	1
1442	5	7937	1	7896x3	5
1443	5	7940	5	7896x4	5
302x3	5	7941	5	BF-40X	1
7921	1	7970	2		
7934A	5	7972	1		



DC-121 • PLASTIC DRAIN COCK ASSORTMENT

To address your plastic drain cock needs, Weatherhead now offers a full assortment of domestic and offshore drain cocks. This kit comes complete with a plastic box and a label with part number and application information.

Catalog Number	Qty.	Catalog Number	Qty.	Catalog Number	Qty.
110	2	113	2	116	2
111	2	114	2	117	2
112	2	115	2	135	2
				145	2

PC-48 • PUSH > CONNECT FITTINGS ASSORTMENT

Weatherhead PUSH > CONNECT fittings are designed for quick assembly without the need for a wrench. Ideal for pneumatic applications where space is tight. Then fittings are also easily disconnected; simply depress the collet ring with two fingers and withdraw the tube. The PC-48 provides the 48 most popular PUSH > CONNECT fittings in a compact, handy plastic box to make your assortment organized and accessible.



Catalog Number	Qty.	Catalog Number	Qty.	Catalog Number	Qty.
1162x2	5	1168x2.5A	5	1169x4S	5
1162x4	5	1168x2.5x4	5	1169x4x4S	5
1162x6	5	1168x2x4	5	1169x4x6S	5
1164x2.5	5	1168x4	5	1169x6S	5
1164x4	5	1168x4A	5	1169x6x6S	5
1164x6	5	1168x4x4	5	1169x8S	2
1164x8	2	1168x4x6	5	1169x8x4S	2
1165x2.5	5	1168x5	5	1171x4S	5
1165x4	5	1168x5x4	5	1171x4x4S	5
1165x6	5	1168x6	5	1171x6S	5
1165x8	2	1168x6x6	5	1172x4S	5
1166x4	5	1168x6x8	2	1172x4x4S	5
1166x4x4	5	1168x8	5	1174x2	5
1166x6	5	1168x8x8	2	1174x4	5
1166x6x6	2	1169x2.5S	5	CL-499	1
1168x2	2	1169x2S	5	FC-16X	1
1168x2.5	5	1169x2x4S	5		



BA-84 • STEEL BRAKE LINE ASSORTMENT

The BA-84 attractive lobby merchandiser displays domestic as well as import car (British, European and Japanese) steel brake lines. The BA-84 puts brake lines where users can make fast and easy selection from a complete inventory protected by sturdy cardboard color-coded tubes.

The corrosion and vibration resistant double wall steel brake lines are easily formed into the configurations you need without kinking. Longer or non-standard lengths can be made up by joining two lines with a Weatherhead union of the proper thread size.

The BA-84 includes all sizes of the 3/16", 1/4" and 5/16" Weatherhead steel brake lines for domestic cars and trucks plus a sturdy steel rack. Order the SB series (Jaguar, M.G., Triumph), SC series (BMW, Mercedes, Peugeot, Porsche, Volkswagen), SJ series (Mazda, Nissan, Toyota) and Weatherhead import car steel brake lines and unions from listings in brake line section of this catalog. See page 128.

Increase your sales — Organize your inventory — Make selections easy — Discover the results of putting this proven money maker to work for you — Install a BA-84 **NOW**.

3/16" LINES			1/4" LINES		
Length	Catalog Number	Quantity	Length	Catalog Number	Quantity
6"	S306	4	12"	S412	4
8"	S308	4	20"	S420	4
12"	S312	4	30"	S430	4
20"	S320	4	40"	S440	4
30"	S330	4	51"	S451	4
40"	S340	4	60"	S460	4
51"	S351	4			
60"	S360	4			
72"	S372	4			

5/16" LINES					
Length	Catalog Number	Quantity	Length	Catalog Number	Quantity
12"	S512	4	Rack	BA-84X	1
20"	S520	4			
30"	S530	4			
40"	S540	4			
51"	S551	4			
60"	S560	4			

RELATED
PROD

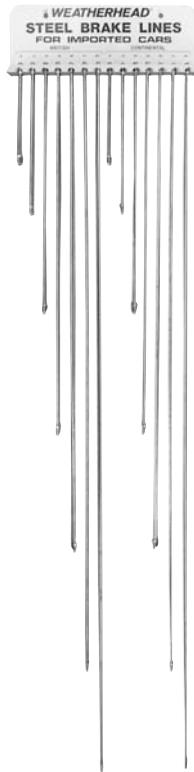

BA-24 • STEEL BRAKE LINE ASSORTMENT

The BA-24 assortment includes an assortment of 5/16" steel brake lines and a rack for wall or bin installation. The multi-walled corrosion resistant tubing can be easily formed for time saving installation. All lines have color-coded label attached for easy identification. Non-standard lengths can be made up by joining two standard lengths with a 302x5 union. **WEIGHT:** 6 lbs.

Length	Catalog Number	Quantity	Length	Catalog Number	Quantity	Length	Catalog Number	Quantity
12"	S512	4	30"	S530	4	51"	S551	4
20"	S520	4	40"	S540	4	60"	S560	4
						Rack	BA-24X	1

BA-28 • STEEL BRAKE LINE ASSORTMENT

BA-28 contains 3/16" easy to form, anti-corrosive, multi-walled steel brake lines for Japanese vehicles. The SJ lines with 10-1.0mm threads (standard flare) can be joined to form longer lines by using the 7934A Japanese metric union. The handy wall rack is included.

Length	Catalog Number	Quantity	Length	Catalog Number	Quantity	Length	Catalog Number	Quantity
8"	SJ308	4	30"	SJ330	4	51"	SJ351	4
12"	SJ312	4	40"	SJ340	4	60"	SJ360	4
20"	SJ320	4				Rack	BA-28X	1

BA-38 • STEEL BRAKE LINE ASSORTMENT

BA-38 contains six different lengths made of 3/8" multi-walled, easily formed, anti-corrosive steel tubing with inverted flare nuts attached. All lines have color-coded label for easy identification. Non-standard length lines may be fabricated by joining two 3/8" steel lines with a 302x6 union. **WEIGHT:** 8 lbs.

Length	Catalog Number	Quantity	Length	Catalog Number	Quantity	Length	Catalog Number	Quantity
12"	S612	4	30"	S630	4	51"	S651	4
20"	S620	4	40"	S640	4	60"	S660	4
						Rack	BA-38X	1

BA-48 • STEEL BRAKE LINE ASSORTMENT

BA-48 contains the most popular steel brake lines and an easy to install rack. The 3/16" and 1/4" steel brake lines are available in six different lengths. Each steel brake line has a standard inverted flare nut on one end and a long thread inverted flare nut on the other end for better sealing. Easy to form, multi-walled steel tubing resists corrosion and vibration.

Non-standard length lines may be fabricated by joining two 3/16" lines with a 302x3 and two 1/4" lines with a 302x4. **WEIGHT:** 10-1/2 lbs.

3/16" LINES			1/4" LINES			1/4" LINES		
Length	Catalog Number	Quantity	Length	Catalog Number	Quantity	Length	Catalog Number	Quantity
12"	S312	4	12"	S412	4	51"	S451	4
20"	S320	4	20"	S420	4	60"	S460	4
30"	S330	4	30"	S430	4	Rack	BA-48X	1
40"	S340	4	40"	S440	4			
51"	S351	4						
60"	S360	4						

BA-56 • STEEL BRAKE LINE ASSORTMENT

BA-56 contains 3/16" easy to form, anti-corrosive, multi-walled steel brake lines for British and European cars. The SB lines with 3/8-24 threads (Bubble Flare) can be joined to form longer lines by using the 7940 metric union. SC lines with 10X1.0mm threads (Bubble Flare) can be joined with the 7941 metric union. The handy wall rack is included. **WEIGHT:** 10 lbs.

British 3/8-24 Thread			European 10-1.0mm Thread			European 10-1.0mm Thread		
Length	Catalog Number	Quantity	Length	Catalog Number	Quantity	Length	Catalog Number	Quantity
8"	SB308	4	8"	SC308	4	40"	SC340	4
12"	SB312	4	12"	SC312	4	51"	SC351	4
20"	SB320	4	20"	SC320	4	60"	SC360	4
30"	SB330	4	30"	SC330	4	Rack	BA-56X	1
40"	SB340	4						
51"	SB351	4						
60"	SB360	4						

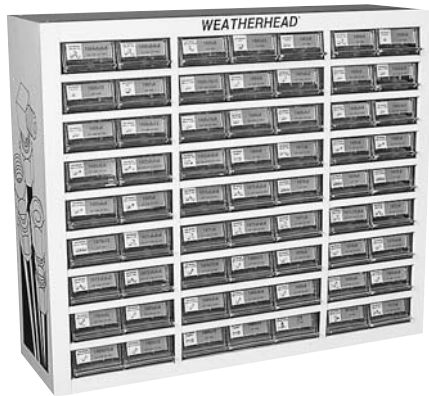

AB-1400 • AIR BRAKE FITTINGS ASSORTMENT

The AB-1400 contains DOT approved brass air brake fittings for servicing nylon brake and secondary air lines. Selecting the proper fittings from the 63 drawer cabinet included with assortment is easy. Clear, wide plastic drawers with color-coded labels make identification of shapes and sizes quick and simple. Order Weatherhead NT100 nylon air brake tubing to complete your nylon air brake line service center.

AB-1400 Contents

Catalog Number	Quantity	Catalog Number	Quantity	Catalog Number	Quantity	Catalog Number	Quantity
1460x4	10	1464x6	5	1469x6	10	1472x6	5
1460x6	20	1464x8	5	1469x6L	5	1472x8	5
1460x8	10	1466x6	5	1469x6x2	5	1480x6	5
1460x10	10	1466x6x6	5	1469x6x6	5	1480x6x6	5
1460x12	10	1466x8	5	1469x8	5	1480x8	5
1461x4	5	1468x4	5	1469x8x4	5	1480x10	4
1461x6	10	1468x4x4	5	1469x10	5	1484x4	20
1461x8	5	1468x6	10	1469x10x6	4	1484x6	20
1461x10	5	1468x6x2	5	1469x12	4	1484x8	20
1461x12	5	1468x8	5	1471x4	5	1484x10	10
1462x4	5	1468x10	5	1471x6	5	1484x12	10
1462x6	10	1468x12	4			C-63X	1
1462x8	5	1469x4	5			CL-497	1
1462x10	4	1469x4x4	5				
1462x12	2						



AB-140 • 1400 SERIES AIR BRAKE FITTINGS ASSORTMENT

This assortment of 1/4", 3/8", 1/2" air brake fittings designed for use with NT100 nylon air brake tubing provides the coverage needed for service work by fleets, repair shops and farm implement dealers. The DOT approved air brake fittings are easily selected from the cabinet with 16 plastic drawers and color-coded labels included in the assortment.

AB-140 Contents

Catalog Number	Quantity	Catalog Number	Quantity	Catalog Number	Quantity	Catalog Number	Quantity
1460x4	20	1461x8	5	1468x6	10	1484x6	20
1460x6	20	1462x4	5	1468x8	5	1484x8	20
1460x8	20	1462x6	10	1469x4	5	145	10
1461x4	10	1462x8	4	1469x6	5	CL-16-3	1
1461x6	10	1468x4	10	1469x8	5	FC-16X	1
				1484x4	20	W15310	5

QC-18

Designed as a glove box sized emergency repair kit, the QC-18 assortment contains Q-CAB® tube unions in 5/32", 3/16", 1/4", 3/8" and 1/2" sizes, also included is a **T-191** tubing cutter. The contents are contained in a convenient carrying case measuring 1-1/4"x3-3/4"x7".



Component Part Number	Quantity
1862x2.5	2
1862x3	2
1862x4	2
1862x6	2
1862x8	2
T-191	1
QC-18X	1

QC-180

The QC180 contains tube unions, male connectors, swivel male 45° elbow, male 90° elbows and repair kits in popular 1/4", 3/8" and 1/2" tube sizes designed for D.O.T. Truck and Trailer Air Brake System needs (see complete listing below). The Q-CAB® fittings are field proven with over millions of miles of leak free performance. Their design can save up to 75% of the assembly time over conventional compression fittings. These fittings are contained in a case measuring 1-3/4"x6-3/4"x1-3/4".



QC-180	Contents Part Number	Quantity	Contents Part Number	Quantity
	1862x3	2	1869x6x6	2
1862x4	2	1869x8x8	1	
1862x6	2	1880x4x4	2	
1862x8	2	1880x6x6	2	
1868x2.5	2	1880x8x8	1	
1868x3	2	1800Kx4	2	
1868x4x4	2	1800Kx6	2	
1868x6x6	2	1800Kx8	2	
1868x8x8	2	1800TRK	1	
1869x4x4	2	BF-40X	1	

QC-1800

This assortment contains a solid inventory of popular Weatherhead Q-CAB® fittings designed for D.O.T. Truck and Trailer Air Brake System needs (see complete listing below). The Q-CAB® fittings are field proven with over millions of of leak free performance. Their design can save up to 75% of the assembly time over conventional compression fittings.



QC-1800	Contents Part Number	Quantity	Contents Part Number	Quantity	Contents Part Number	Quantity	Contents Part Number	Quantity
	1800Kx2.5	4	1862x10	2	1868x12	2	1874x6x6	1
1800Kx3	4	1868x2.5x1	5	1869x4	5	1874x8x8	1	
1800Kx4	4	1868x2.5	5	1869x4x4	5	1880x4x4	5	
1800Kx6	4	1868x3	5	1869x6	5	1880x6x6	5	
1800Kx8	4	1868x4	5	1869x8	5	1880x8x8	5	
1800Kx10	2	1868x4x4	5	1869x8x8	5	1880x10	2	
1800Kx12	2	1868x6	5	1869x10	2	1880x12	2	
1862x2.5	2	1868x6x6	5	1869x4S	5	1800T	1	
1862x3	5	1868x8	5	1869x4x4S	5	CL-503	1	
1862x4	5	1868x8x8	5	1869x6S	5	FC-16X	1	
1862x6	5	1868x10x6	2	1869x8S	5	T-191	1	
1862x8	5	1868x10	2	1874x4x4	1			

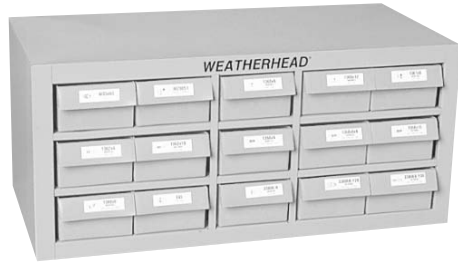

AB-45 • AIR BRAKE FITTINGS ASSORTMENT

This assortment of draincocks, shutoffs and air brake fittings for use with 1/4", 3/8", 1/2" copper tubing is a must for jobbers and fleet service shops. Provides excellent coverage for air brake tube and hose service requirements. The large plastic drawers and the illustrated labels for the 15 drawer cabinet included in assortment make positive part selection simple and quick.

AB-45 Contents

Catalog Number	Quantity	Catalog Number	Quantity	Catalog Number	Quantity	Catalog Number	Quantity
1360x6	20	1368x6	10	145	10	6747	1
1360x8	20	1368x6x2	5	33806-A	20	6748	1
1360x10	10	1368x6x6	5	33806-B	5	6749	1
1360x12	10	1368x8	5	33806B-Y06	2	FH-15X	1
1361x6	20	1368x10	5	33806B-Y24	5	FS-800	1
1361x8	5	1369x4x4	5	33806B-Y28	5	W05465	5
1361x10	5	1369x6	10	33806B-Y34	5	W14630	10
1362x4	5	1369x8	5	33806B-Y38	5	W15310	5
1362x6	10	1380x6	5	6707	1	W76150	5
1362x8	5	1390x6	5	6708	1	W79850	3
1362x10	5	1391x6	5	6709	1	W79851	3



AB-28 • AIR BRAKE FITTINGS ASSORTMENT

The 1/4", 3/8", 1/2" brass air brake fittings for use with copper tubing provide excellent coverage for fleets, independent repair shops and farm implement dealers doing service work.

With the AB-28 assortment you also receive a cabinet with clear plastic drawers plus illustrated, color-coded labels that assure fast, positive identification and selection of replacement fittings.

AB-28 Contents

Catalog Number	Quantity	Catalog Number	Quantity	Catalog Number	Quantity	Catalog Number	Quantity
1360x4	20	1361x10	5	1368x8	5	33806B-Y28	5
1360x6	20	1361x12	5	1369x4	5	33806B-Y34	5
1360x8	20	1362x6	5	1369x6	10	33806B-Y38	5
1360x10	10	1362x8	5	145	10	CL-16-2	1
1360x12	10	1362x10	5	33806-A	20	FC-16X	1
1361x4	5	1368x4	5	33806B-Y06	2	W14630	10
1361x6	20	1368x6	10	33806B-Y24	5	W15310	5
1361x8	5	1368x6x6	5				



SA-1 • SECONDARY AIR SYSTEMS KIT

Ideal for fleet repair shops, truck dealers, garages and truck stops. SA-1 contains an assortment of popular 1/8" and 1/4" brass fittings plus 200' of Weatherhead NT100 SAE J844 Nylon tubing. The 1/8" fittings are Weatherhead SELFALIGN® and 1/4" fittings are Weatherhead 1400 series air brake. The sturdy box keeps the tubing and fittings together for quick and easy servicing of the tubing used on shifters, PTO's, wipers, horns, remote air, instrumentation, etc. All of the parts are organized at your finger tips. The SA-1 is a must for all vehicle air system maintenance facilities.

Size: 15" wide, 3-1/2" high, 14-1/2" deep.

Catalog Number	Qty.	Catalog Number	Qty.
1460x4	10	601x2	10
1461x4	5	611x2	5
1462x4	2	621x2	2
1464x4	1	661x2	2
1468x4	2	681x2	2
1468x4x1	2	681x2x1	2
1468x4x4	2	691x2	2
1469x4	2	691x2x1	2
1469x4x4	2	BF-40X	1
1484x4	5	NT10002BK-100	100'
		NT10004BK-100	100'



SA-2 • SECONDARY AIR SYSTEMS KIT

The SA-2 assortment enables you to supply fleets and dealers with fittings and tubing for 1/4" and 3/8" O.D. air brake applications. 1/8" O.D. tubing and fittings are also supplied for applications such as transmission shifter, air horn, gauge and flat adjustment. A cabinet is also supplied for easy storage on shelves and bench tops.

Catalog Number	Qty.	Catalog Number	Qty.
1460x4	10	1468x6x2	5
1460x6	20	1468x6x6	5
1461x4	5	1468x6x8	5
1461x6	10	1469x4	5
1462x4	5	1469x4x4	5
1462x6	10	1469x6	10
1464x4	2	1469x6x6	5
1464x6	2	601x2	10
1466x6	5	611x2	10
1468x4	5	621x2	5
1468x4x4	5	661x2	5
1468x4x6	2	681x2	5
1472x4	5	681x2x1	2
1472x6	5	691x2	5
1472x6x6x6	5	691x2x1	2
1484x4	10	BL-456-X	1
1484x6	10	FS-SA-2	1
1485x4	10	NT10002BK-100	100'
1485x6	10	NT10004BK-100	100'
1468x6	10	NT10006BK-100	100'



AB-8 & AB-9 • Air Brake Air Chamber Hose

Assembly Assortment of 3/8" and 1/2" I.D. Lines

Each selection of ready-made air chamber hose assemblies facilitates replacement of hoses. Eliminates time and cost of making special assemblies. Wall rack keeps assemblies handy and ready to use.

AB-8 • 1/2" I.D. Air Brake Air Chamber Lines

Length	Qty.	Catalog Number	Length	Qty.	Catalog Number
18-1/2"	1	38353-01800	32"	1	38353-03200
20-3/8"	1	38353-02037	34-3/8"	1	38353-03437
24-1/8"	1	38353-02400	36-1/8"	1	38353-03600
28-3/8"	1	38353-02837	41-1/8"	1	38353-04112
30-1/8"	1	38353-03000	Rack	1	AB-8X

Replacement Labels [AB-8L](#)

AB-9 • 3/8" I.D. Lines Air Brake Air Chamber Lines

Length	Qty.	Catalog Number	Length	Qty.	Catalog Number
18-1/2"	1	38166-01812	32"	1	38166-03200
20-3/8"	2	38166-02137	34-3/8"	1	38166-03437
24-1/8"	2	38166-02412	36-1/8"	2	38166-03612
28-3/8"	2	38166-02837	41-1/8"	1	38166-04112
30-1/8"	2	38166-03012	Rack	1	AB-9X

Replacement Labels [AB-9L](#)

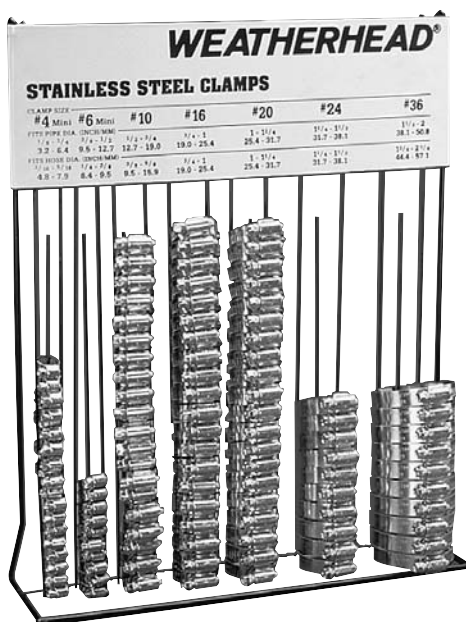

CA-130 & CA-230 • Clamp Assortments

You can now increase your all-stainless steel or part-stainless steel clamp sales with these all-purpose clamp assortments. These rugged assortments can be wall mounted or stand free using less than 2 sq. ft. of counter space. They load easily and organize your merchandise effectively.

CA-130 • Part-Stainless Steel

Catalog Number	Quantity	Catalog Number	Quantity
6205-004	20	6203-024	10
6205-006	10	6203-036	10
6203-010	20	CA-10X	1
6203-016	20		
6203-020	20		

CA-230 • All-Stainless Steel

Catalog Number	Quantity	Catalog Number	Quantity
6204-010	20	6206-004	20
6204-016	20	6206-006	10
6204-020	20	CA-10X	1
6204-024	10		
6204-036	10		

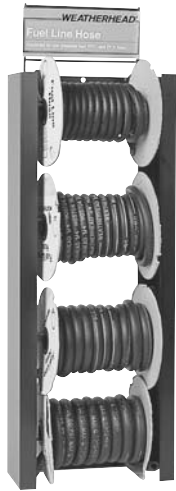

HA-574 • Fuel Hose Merchandiser

Now you can make those custom hose assemblies in minutes for instant service on fuel and oil line replacements. The attractive HA-574 includes H057 hose in all popular sizes for low pressure fuel, EEC and PCV lines. Weatherhead H057 low pressure fuel line hose has Nitrile inner tube, fiber braid reinforcement, and Hypalon cover for long life compatibility with gasohol, leaded and unleaded fuels. The HC-574X rack can be easily installed on pegboard, wall, or metal shelving with the included hardware.

Catalog Number	Quantity	Description
H05703-25R	25'	Hose
H05704-25R	25'	Hose
H05705-25R	25'	Hose
H05706-25R	25'	Hose
HC-574X	1	Rack

BL-456 • Barb-Tite® Fittings and Hose Assortment

Making up an air line – oil line – transmission or power steering return line? The BL-456 assortment puts Weatherhead Barb-Tite® fittings and 1/4", 5/16", and 3/8" I.D. 350 PSI maximum operating pressure H101 hose at your fingertips for quick and easy assembly. Simply push ends on hose, and you have a hose assembly. No clamps required!

Your hose will be kept clean and easily accessible on three shelves in the cabinet. Measure the hose on top of the cabinet with the rule provided and then select the proper hose ends from the assortment in the two metal drawers. Within minutes the hose assembly is ready for installation.

Size: 15" wide, 16-1/2" high, 13-3/16" deep

16 Compartments in each drawer.



Catalog Number	Qty.	Catalog Number	Qty.
10004B-102	4	10004B-B04	4
10004B-104	4	10004B-B05	4
10004B-304	4	10004B-Y04	4
10004B-305	4	10005B-102	4
10004B-405	4	10005B-104	4
10004B-604	4	10005B-405	4
10004B-A04	4	10005B-B05	4
10004B-A05	4	10005B-B06	4
10004B-B03	4		
Catalog Number	Qty.	Catalog Number	Qty.
10005B-C02	4	10006B-606	4
10005B-C04	4	10006B-B06	4
10005B-Y05	4	10006B-Y06	4
10006B-102	4	BL-456X	1
10006B-104	4	FS-501	1
10006B-106	4	H10104	50'
10006B-306	4	H10105	50'
10006B-406	4	H10106	50'

These assortments are ideal for servicing that fleet account. The D.O.T. approved hose and fittings will enable the user to make up chamber lines, connect to gladhand couplings, and provide routing for air brake lines. The general purpose H069 provides for fuel, oil, water, power steering, and transmission lines. A self-contained assortment in a super cabinet, all set up for easy serviceability!



FA-100 • Fleet Hose and Fitting Assortment

Catalog Number	Qty	Catalog Number	Qty	Catalog Number	Qty
24704N-102	5	24706N-B06	5	33806B-Y28	5
24704N-104	5	24708N-106	5	33806B-Y34	5
24704N-604	5	24708N-108	5	33806B-Y36	5
24704N-B04	5	24708N-406	5	33806B-Y38	5
24705N-104	5	24708N-608	5	FH-15X	1
24705N-605	5	24710B-Y58	2	H06904	50'
24705N-B05	5	24710B-Y60	5	H06906	50'
24706N-104	5	24710N-108	5	H06908	50'
24706N-106	5	24710N-608	5	H06910	50'
24706N-406	5	24710N-610	2	H16606	50'
24706N-604	5	33806-A	20	H16608	50'
24706N-605	5	33806-B	5	H33806	50'
24706N-606	5	33806B-Y06	5	HD-1X	1
24706N-608	5	33806B-Y24	5		
24706N-756	5	33806B-Y26	2		

FA-100-CO • Fleet Hose and Fitting Assortment (Contents Only)

Catalog Number	Qty	Catalog Number	Qty	Catalog Number	Qty
24704N-102	5	24706N-756	5	33806B-Y24	5
24704N-104	5	24706N-B06	5	33806B-Y26	2
24704N-604	5	24708N-106	5	33806B-Y28	5
24704N-B04	5	24708N-108	5	33806B-Y34	5
24705N-104	5	24708N-406	5	33806B-Y36	5
24705N-605	5	24708N-608	5	33806B-Y38	5
24705N-B05	5	24710B-Y58	2	H06904	50'
24706N-104	5	24710B-Y60	5	H06906	50'
24706N-106	5	24710N-108	5	H06908	50'
24706N-406	5	24710N-608	5	H06910	50'
24706N-604	5	24710N-610	2	H16606	50'
24706N-605	5	33806-A	20	H16608	50'
24706N-606	5	33806-B	5	H33806	50'
24706N-608	5	33806B-Y06	5		

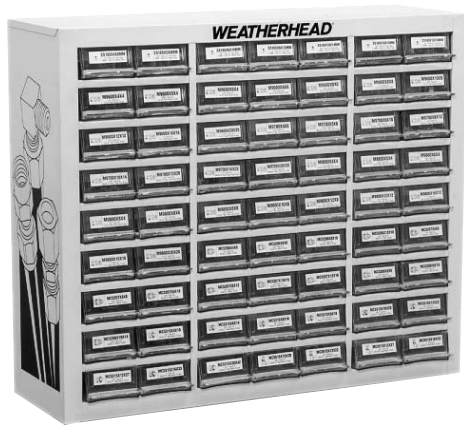

MA-100 • Metric Adapter Assortment

The MA-100 is an ideal assortment to begin a metric adapter inventory. Offered are a variety of male British Standard Tapered Pipe and British Standard Parallel fittings in straight and 90° elbow configurations, sizes ranging from 1/8" through 1-1/4". Two male DIN (German metric) fittings adapt SAE fittings and hose ends to metric size tubing, and a third DIN fitting connects SAE fittings with metric female swivel adapters, sizes ranging from 6mm through 42mm. The C5165X metric sleeves adapt metric tubing used with standard JIC fittings. The MA-100 is supplied with cabinet for accurate and easy access to your metric fittings.

Replacement Drawers: **PD-49** (Individual)
 Replacement Dividers: **PD-75 Set** (25/set)

MA-100 Contents

Catalog Number	Qty.	Catalog Number	Qty.	Catalog Number	Qty.	Catalog Number	Qty.	Catalog Number	Qty.
7165X6MM	5	M9700X5X8	2	MB5515X6X4	5	MC5208X6X6	2	MH7105X6	5
7165X8MM	2	M9700X6X10	2	MB5515X6X6	5	MC5208X8X10	2	MH7105X8	5
7165X10MM	5	M9700X8X12	2	MB5515X8X6	5	MC5208X10X14	2	MH7105X10	5
7165X12MM	5	M9700X10X14	2	MB5515X8X8	5	MC5208X12X16	2	MH7105X12	5
7165X14MM	5	M9700X12X20	2	MB5515X10X12	5	MC5315X4X10	2	MH7105X14	5
7165X15MM	5	M9700X16X25	2	MB5515X12X12	5	MC5315X4X12	2	MH7105X16	5
7165X16MM	5	M9700X20X32	1	MB5515X16X16	2	MC5315X6X14	2	MH7105X20	5
7165X18MM	5	M9800X4X4	2	MB5515X20X20	2	MC5315X6X16	2	MH7105X25	5
7165X20MM	5	M9800X5X4	2	MC5205X4X2	5	MC5315X8X18	2	MH7105X30	5
7165X22MM	5	M9800X6X4	2	MC5205X4X4	5	MC5315X10X20	2	ML7105X6	5
7165X25MM	5	M9800X8X4	2	MC5205X5X4	5	MC5315X12X22	2	ML7105X8	5
7165X28MM	5	M9800X8X6	2	MC5205X6X4	5	MC5315X12X27	2	ML7105X10	5
7165X30MM	5	M9800X8X8	2	MC5205X6X6	5	MC5315X16X33	2	ML7105X12	5
M7629X10	5	M9800X10X8	2	MC5205X8X6	5	MC5315X20X42	1	ML7105X15	5
M7629X14	5	M9800X12X8	2	MC5205X8X8	5	MC5405X4X4	5	ML7105X18	5
M7629X16	5	M9800X12X12	2	MC5205X10X8	5	MC5405X5X4	5	ML7105X22	5
M7629X18	5	M9800X16X12	2	MC5205X10X12	5	MC5405X6X4	5	ML7105X28	5
M7629X20	5	M9800X16X16	2	MC5205X12X12	5	MC5405X6X6	5	C5165X4X6MM	5
M7629X22	5	M9800X20X20	1	MC5205X16X16	2	MC5405X8X6	5	C5165X5X8MM	5
M7629X27	5	MB5315X4X2	5	MC5205X20X20	2	MC5405X8X8	5	C5165X6X10MM	5
M7629X33	5	MB5315X4X4	5	MC5206X4X6	2	MC5405X10X12	5	C5165X8X12MM	5
M7629X42	5	MB5315X5X4	5	MC5206X6X8	2	MC5405X12X12	5	C5165X10X14MM	5
M9600X4X4	2	MB5315X6X4	5	MC5206X8X10	2	MC5405X16X16	2	C5165X10X15MM	5
M9600X5X4	2	MB5315X6X6	5	MC5206X8X12	2	MC5405X20X20	2	C5165X10X16MM	5
M9600X6X4	2	MB5315X8X6	5	MC5206X10X15	2	MC5515X4X12	2	C5165X12X18MM	5
M9600X6X6	2	MB5315X8X8	5	MC5206X12X18	2	MC5515X6X14	2	C5165X14X20MM	5
M9600X8X6	2	MB5315X10X12	5	MC5207X4X6	2	MC5515X6X16	2	C5165X16X25MM	5
M9600X8X8	2	MB5315X12X12	5	MC5207X6X8	2	MC5515X8X18	2	C5165X20X30MM	5
M9600X10X8	2	MB5315X16X16	2	MC5207X6X10	2	MC5515X10X20	2	C5165X20X32MM	5
M9600X12X12	2	MB5315X20X20	2	MC5207X8X12	2	MC5515X12X22	2	C-5X	1
M9600X16X16	2	MB5515X4X4	5	MC5207X10X15	2	MC5515X12X27	2	C-63X	1
M9600X20X20	1	MB5515X5X4	5	MC5207X12X18	2	MC5515X16X33	1	CL-502	1
M9700X4X6	2							TA-1002	1



MA-200 • Metric Hose End Assortment

The MA-200 Hose End Assortment offers an excellent introductory stock of metric hose ends. Coverage includes 'U' Series British Standard Tapered Pipe (BSPT) and British Standard Parallel Pipe (BSPP) in male straight, and female swivel in straight and 90° tube elbow connections, swivels, and split flange ends for Komatsu and Link Belt applications and DIN standpipe hose ends in light and heavy series. One FH-15X stock cabinet is supplied for storage.

MA-200 Contents

Catalog Number	Qty.	Catalog Number	Qty.	Catalog Number	Qty.	Catalog Number	Qty.	Catalog Number	Qty.
04U-14K	2	06U-76P	2	12U-162	2	16U-P66	2	MH7105X14	2
04U-154	5	08U-158	5	12U-30K	2	7165X8MM	5	MH7105X16	2
04U-354	5	08U-22K	2	12U-362	2	7165X10MM	4	MH7105X20	2
04U-38T	2	08U-358	5	12U-52T	2	7165X12MM	2	MH7105X25	2
04U-40T	2	08U-360	5	12U-55T	2	7165X14MM	2	MH7105X30	1
04U-P54	5	08U-45T	2	12U-G12	2	7165X15MM	2	ML7105X8	2
04U-74P	2	08U-46T	2	12U-G42	2	7165X16MM	2	ML7105X10	2
06U-156	5	08U-P56	2	12U-P62	2	7165X18MM	2	ML7105X12	2
06U-18K	2	08U-P58	2	12U-82P	2	7165X20MM	2	ML7105X15	2
06U-356	5	08U-78P	2	16U-166	2	7165X22MM	2	ML7105X18	2
06U-358	2	08U-80P	5	16U-33K	2	7165X25MM	2	ML7105X22	2
06U-40T	2	10U-24K	2	16U-366	2	7165X28MM	2	ML7105X28	2
06U-42T	2	10U-48T	2	16U-58T	2	7165X30MM	1	FH-15X	2
06U-44T	2	10U-50T	2	16U-60T	1	MH7105X8	2	FS-2500	1
06U-P56	2	10U-G09	2	16U-G16	2	MH7105X10	2		
06U-P58	2	10U-G69	2	16U-G46	2	MH7105X12	2		



FL-310 • Fuel Hose and Fittings Assortment

FL-310 contains 250' of Weatherhead fuel line hose, a variety of brass hose end fittings, and gear-type clamps for easy, instant service on fuel and oil line assemblies.

A well-designed cabinet keeps 1/4", 5/16", 3/8", or 7/16" I.D. hose on reels free of kinks and tangles...ready for instant use. Ten clear plastic drawers with color-coded illustrated labels are provided for storing hose end fittings and clamps. H057 hose is compatible with unleaded gasolines and low pressure fuel systems.

Size: 30" wide, 13-1/2" high, 13" deep

Catalog No.	Qty.	Catalog No.	Qty.	Catalog No.	Qty.
05704B-102	10	05705B-C04	5	6202	20
05704B-104	5	05706B-102	10	CL-434	1
05704B-C02	5	05706B-104	10	FL-310X	1
05705B-102	10	05706B-106	5	H05704-100R	100'
05705B-104	10	05706B-1568	5	H05705-100R	100'
05705B-1560	5	05706B-1570	5	H05706-100R	50'
05705B-1561	5	05706B-C02	5		
05705B-C02	5	05706B-C04	5		

RELATED PRODUCT

Weatherhead

Facility	Registration	Registrar Number	Product Responsibility
Antwerp, OH	ISO/QS9000	TUV 74 300 7687	Steel Hose Ends
Brentwood, TN (Engineering)	ISO/QS9000	UL A5225	New Product Designs
Cleveland, TN	ISO9002	SGS US98/1495	Distribution of Weatherhead Product
Columbia City, IN ISO14001	ISO9002 97-956	INTERTEK	Crimping Equipment
Hohenwald, TN	ISO/QS9000 ISO14001	UL A5216	Industrial and Hydraulic Hose
Ludlow, MA	ISO/QS9000	TUV 74 300 8803	Teflon Hose and Assembly
Newbern, TN	ISO9001 ISO14001	UL A5754	Industrial and Hydraulic Hose
Vinita, OK	ISO/QS9000 ISO14001	UL A5225 A6947	Brass Fittings, Brass Hose Ends, and Valves

Conversion Chart

Conversion

Inches			Inches			Inches			Inches		
Fractions	Decimals	MM	Fractions	Decimals	MM	Fractions	Decimals	MM	Fractions	Decimals	MM
-	.0004	.0100	-	.6693	17.0000	1-25/32	1.7810	45.2440	-	3.1102	79.0000
-	.0040	.1000	43/64	.6720	17.0660	-	1.8110	46.0000	3-1/8	3.1250	79.3750
-	.0100	.2500	11/16	.6875	17.4630	1-13/16	1.8125	46.0380	-	3.1496	80.0000
1/64	.0156	.3970	45/64	.7030	17.8590	1-27/32	1.8440	46.8310	3-5/32	3.1560	80.1690
-	.0197	.5000	-	.7087	18.0000	-	1.8504	47.0000	3-3/16	3.1875	80.9630
-	.0295	.7500	23/32	.7190	18.2560	1-7/8	1.8750	47.6250	-	3.1890	81.0000
1/32	.0313	.7940	-	.7283	18.5000	-	1.8898	48.0000	3-7/32	3.2190	81.7560
-	.0394	1.0000	47/64	.7340	18.6530	1-29/32	1.9062	48.4190	-	3.2283	82.0000
3/64	.0469	1.1910	-	.7480	19.0000	-	1.9291	49.0000	3-1/4	3.2500	82.5500
-	.0590	1.5000	3/4	.7500	19.0500	1-15/16	1.9375	49.2130	-	3.2677	83.0000
1/16	.0620	1.5880	49/64	.7656	19.4470	-	1.9685	50.0000	3-9/32	3.2810	83.3440
5/64	.0781	1.9840	25/32	.7810	19.8440	1-31/32	1.9690	50.0060	-	3.3071	84.0000
-	.0787	2.0000	-	.7874	20.0000	2	2.0000	50.8000	3-5/16	3.3120	84.1377
3/32	.0940	2.3810	51/64	.7970	20.2410	-	2.0079	51.0000	3-11/32	3.3440	84.9314
-	.0984	2.5000	13/16	.8125	20.6380	2-1/32	2.0313	51.5940	-	3.3464	85.0000
7/64	.1090	2.7780	-	.8268	21.0000	-	2.0472	52.0000	3-3/8	3.3750	85.7250
-	.1181	3.0000	53/64	.8280	21.0340	2-1/16	2.0620	52.3880	-	3.3858	86.0000
1/8	.1250	3.1750	27/32	.8440	21.4310	-	2.0866	53.0000	3-13/32	3.4060	86.5190
-	.1378	3.5000	55/64	.8590	21.8280	2-3/32	2.0940	53.1810	-	3.4252	87.0000
9/64	.1410	3.5720	-	.8662	22.0000	2-1/8	2.1250	53.9750	3-7/16	3.4380	87.3130
5/32	.1560	3.9690	7/8	.8750	22.2250	-	2.1260	54.0000	-	3.4646	88.0000
-	.1575	4.0000	57/64	.8906	22.6220	2-5/32	2.1560	54.7690	3-15/32	3.4690	88.1060
11/64	.1720	4.3660	-	.9055	23.0000	-	2.1650	55.0000	3-1/2	3.5000	88.9000
-	.1770	4.5000	29/32	.9062	23.0190	2-3/16	2.1875	55.5630	-	3.5039	89.0000
3/16	.1875	4.7630	59/64	.9220	23.4160	-	2.2047	56.0000	3-17/32	3.5310	89.6940
-	.1969	5.0000	15/16	.9375	23.8130	2-7/32	2.2190	56.3560	-	3.5433	90.0000
13/64	.2030	5.1590	-	.9449	24.0000	-	2.2440	57.0000	3-9/16	3.5620	90.4877
-	.2165	5.5000	61/64	.9530	24.2090	2-1/4	2.2500	57.1500	-	3.5827	91.0000
7/32	.2190	5.5560	31/32	.9690	24.6060	2-9/32	2.2810	57.9440	3-19/32	3.5940	91.2810
15/64	.2340	5.9530	-	.9843	25.0000	-	2.2835	58.0000	-	3.6220	92.0000
-	.2362	6.0000	63/64	.9844	25.0030	2-5/16	2.3120	58.7380	3-5/8	3.6250	92.0750
1/4	.2500	6.3500	1	1.0000	25.4000	-	2.3228	59.0000	3-21/32	3.6560	92.8960
-	.2559	6.5000	-	1.0236	26.0000	2-11/32	2.3440	59.5310	-	3.6614	93.0000
17/64	.2656	6.7470	1-1/32	1.0312	26.1940	-	2.3622	60.0000	3-11/16	3.6875	93.6630
-	.2756	7.0000	1-1/16	1.0620	26.9880	2-3/8	2.3750	60.3250	-	3.7008	94.0000
9/32	.2810	7.1440	-	1.0630	27.0000	-	2.4016	61.0000	3-23/32	3.7190	94.4560
-	.2953	7.5000	1-3/32	1.0940	27.7810	2-13/32	2.4060	61.1190	-	3.7401	95.0000
19/64	.2970	7.5410	-	1.1024	28.0000	2-7/16	2.4380	61.9130	3-3/4	3.7500	92.2500
5/16	.3120	7.9380	1-1/8	1.1250	28.5750	-	2.4409	62.0000	-	3.7795	96.0000
-	.3150	8.0000	-	1.1417	29.0000	2-15/32	2.4690	62.7060	3-25/32	3.7810	96.0440
21/64	.3280	8.3340	1-5/32	1.1560	29.3690	-	2.4803	63.0000	3-13/16	3.8125	96.8380
-	.3350	8.5000	-	1.1811	30.0000	2-1/2	2.5000	63.5000	-	3.8189	97.0000
11/32	.3440	8.7310	1-3/16	1.1875	30.1630	-	2.5197	64.0000	3-26/32	3.8440	97.6310
-	.3543	9.0000	1-7/32	1.2190	30.9560	2-17/32	2.5310	64.2940	-	3.8583	98.0000
23/64	.3590	9.1280	-	1.2205	31.0000	-	2.5590	65.0000	3-7/8	3.8750	98.4250
-	.3740	9.5000	1-1/4	1.2500	31.7500	2-9/16	2.5620	65.0880	-	3.8976	99.0000
3/8	.3750	9.5250	-	1.2598	32.0000	2-19/32	2.5940	65.8810	3-29/32	3.9062	99.2190
25/64	.3910	9.9220	1-9/32	1.2810	32.5440	-	2.5984	66.0000	-	3.9370	100.0000
-	.3937	10.0000	-	1.2992	33.0000	2-5/8	2.6250	66.6750	3-15/16	3.9375	100.0130
13/32	.4060	10.3190	1-5/16	1.3120	33.3380	-	2.6380	67.0000	3-31/32	3.9690	100.8060
-	.4130	10.5000	-	1.3386	34.0000	2-21/32	2.6560	67.4690	-	3.9764	101.0000
27/64	.4220	10.7160	1-11/32	1.3440	34.1310	-	2.6772	68.0000	4	4.0000	101.6000
-	.4331	11.0000	1-3/8	1.3750	34.9250	2-11/16	2.6875	68.2630	4-1/16	4.0620	103.1880
7/16	.4380	11.1130	-	1.3779	35.0000	-	2.7165	69.0000	4-1/8	4.1250	104.7750
29/64	.4530	11.5090	1-13/32	1.4060	35.7190	2-23/32	2.7190	69.0560	-	4.1338	105.0000
15/32	.4690	11.9060	-	1.4173	36.0000	2-3/4	2.7500	69.8500	4-3/16	4.1875	106.3630
-	.4724	12.0000	1-7/16	1.4380	36.5130	-	2.7559	70.0000	4-1/4	4.2500	107.9500
31/64	.4840	12.3030	-	1.4567	37.0000	2-25/32	2.7810	70.6439	4-5/16	4.3120	109.5380
-	.4920	12.5000	1-15/32	1.4690	37.3060	-	2.7953	71.0000	-	4.3307	110.0000
1/2	.5000	12.7000	-	1.4961	38.0000	2-13/16	2.8125	71.4376	4-3/8	4.3750	111.1250
-	.5118	13.0000	1-1/2	1.5000	38.1000	-	2.8346	72.0000	4-7/16	4.4380	112.7130
33/64	.5156	13.0970	1-17/32	1.5310	38.8940	2-27/32	2.8440	72.2314	4-1/2	4.5000	114.3000
17/32	.5310	13.4940	-	1.5354	39.0000	-	2.8740	73.0000	-	4.5275	115.0000
35/64	.5470	13.8910	1-9/16	1.5620	39.6880	2-7/8	2.8750	73.0250	4-9/16	4.5620	115.8880
-	.5512	14.0000	-	1.5748	40.0000	2-29/32	2.9062	73.8190	4-5/8	4.6250	117.4750
9/16	.5630	14.2880	1-19/32	1.5940	40.4810	-	2.9134	74.0000	4-11/16	4.6875	119.0630
-	.5710	14.5000	-	1.6142	41.0000	2-15/16	2.9375	74.6130	-	4.7244	120.0000
37/64	.5790	14.6840	1-5/8	1.6250	41.2750	-	2.9527	75.0000	4-3/4	4.7500	120.6500
-	.5906	15.0000	-	1.6535	42.0000	2-31/32	2.9690	75.4060	4-13/16	4.8125	122.2380
19/32	.5940	15.0810	1-31/32	1.6562	42.0690	-	2.9921	76.0000	4-7/8	4.8750	123.8250
39/64	.6090	15.4780	1-11/16	1.6875	42.8630	3	3.0000	76.2000	-	4.9212	125.0000
5/8	.6250	15.8750	-	1.6929	43.0000	3-1/32	3.0312	76.9940	4-15/16	4.9375	125.4130
-	.6299	16.0000	1-23/32	1.7190	43.6560	-	3.0315	77.0000	5	5.0000	127.0000
41/64	.6406	16.2720	-	1.7323	44.0000	3-1/16	3.0620	77.7880			
-	.6496	16.5000	1-3/4	1.7500	44.4500	-	3.0709	78.0000			
21/32	.6560	16.6690	-	1.7717	45.0000	3-3/32	3.0940	78.5810			

MCS

**JIC 37° and SAE 45° Flare Fittings
For Zinc Plated Carbon without Thread Sealant or Lubrication**

Size	Fraction	Decimal	Lb. / In.	Lb. / Ft.	Newton Meters	Additional Turns of Hex-Flats**
- 04	1/4"	0.250	130-150	11-12	15-17	2
- 05	5/16"	0.312	165-195	14-16	19-22	2
- 06	3/8"	0.375	235-265	20-22	27-30	1-1/4
- 08	1/2"	0.500	525-575	44-48	59-65	1
- 10	5/8"	0.625	600-700	50-58	68-79	1
- 12	3/4"	0.750	950-1050	79-88	107-119	1
- 16	1"	1.000	1400-1500	117-125	158-170	1
- 20	1-1/4"	1.250	1900-2100	158-175	215-237	1
- 24	1-1/2"	1.500	2250-2550	188-213	254-288	1
- 32	2"	2.000	3000-3400	250-283	339-384	1

****Additional Turns of Hex-Flats required after finger tightening. THIS IS THE RECOMMEND METHOD OF TIGHTENING BOTH 37° SWIVELS & 45° FLARE FITTINGS.**

**Straight Thread O-Ring Fittings
For Zinc Plated Steel without Sealant or Lubrication**

Size	Fraction	Decimal	Lb. / In.	Lb. / Ft.	Newton Meters
- 04	1/4"	0.250	156-180	13-15	18-20
- 05	5/16"	0.312	204-228	17-19	23-26
- 06	3/8"	0.375	264-288	22-24	30-33
- 08	1/2"	0.500	480-516	40-43	54-58
- 10	5/8"	0.625	516-576	43-48	58-65
- 12	3/4"	0.750	816-900	68-75	92-102
- 16	1"	1.000	1344-1476	112-123	152-167
- 20	1-1/4"	1.250	1752-1932	146-161	198-218
- 24	1-1/2"	1.500	1848-2040	154-170	209-231
- 32	2"	2.000	2616-2880	218-240	296-325

**For-Seal® Fittings
For Zinc Plated Steel without Thread Sealant or Lubrication**

Size	Fraction	Decimal	For-Seal® Swivel Nut Fitting			O-Ring Boss Straight Thread O-Ring Locknut		
			Lb. / In.	Lb. / Ft.	Newton Meters	Lb. / In.	Lb. - Ft.	Newton Meters
- 04	1/4"	0.250	120-144	10-12	14-16	168-192	14-16	19-22
- 06	3/8"	0.375	216-240	18-20	24-27	288-312	24-26	33-35
- 08	1/2"	0.500	384-420	32-35	43-48	600-720	50-60	68-81
- 10	5/8"	0.625	552-600	46-50	62-68	864-960	72-80	98-109
- 12	3/4"	0.750	780-840	65-70	88-95	1500-1620	125-135	170-183
- 16	1"	1.000	1104-1200	92-100	125-136	2400-2640	200-220	271-298
- 20	1-1/4"	1.250	1500-1680	125-140	170-190	2520-3360	210-280	285-380
- 24	1-1/2"	1.500	1800-1980	150-165	203-224	3240-4320	270-360	366-488

Torque Value Conversion Chart

Lb. / Inch	=	Pound Foot (Lb./Ft.) x 12	Lb. / Foot	=	Pound Inch (Lb./In.) x 0.083
Lb. / Inch	=	Newton Meter x 8.850	Lb. / Foot	=	Newton Meter x 0.737
Newton Meter	=	Pound Inch (Lb./In.) x 0.113	Newton Meter	=	Pound Foot (Lb./Ft.) x 1.356

NOTE: See introduction page of each catalog section for specific ratings.
252 Please consult Boston Weatherhead for other material torque ratings.

Boston Weatherhead Tech Support 1-800-776-3262

Our “800” service is provided for your benefit and is available from 8:00 AM to 7:00 PM Monday through Friday Eastern time.

The Technical Support Group **will** assist you with information relative to:

- Part number interchanges
- Weatherhead part number verification
- Hose, hose ends, and fitting identification based on application information
- Identification of tube and pipe fittings based on description and dimensions
- Applications not listed in current catalogs
- Chemical resistance ratings
- Dimensions
- Coll-O-Crimp hose crimper information, troubleshooting, and replacement parts
- Selection of correct Coll-O-Crimp tooling
- Construction, materials, and properties of hose and fittings
- Weatherhead tools and accessories
- Hose assembly troubleshooting and problem solving
- Referral to a Weatherhead distributor or District Sales Manager

The Technical Support Group **cannot** respond to the following:

- Transfer of calls to another department or the warehouse
- Inventory status
- Backorders
- Pricing and placing orders
- Literature orders
- Competitive pricing

**We appreciate the opportunity to provide these services to you.
Your comments and suggestions are welcome.**

**NO PRODUCT LISTED IN THIS CATALOG HAS BEEN CERTIFIED
FOR AVIATION USE.**

**This catalog and all information herein supersede all previous Weatherhead
catalogs and information material.**

A:

abrasion: external damage to a hose assembly caused by its being rubbed on a foreign object; a wearing away by friction.

ABS: Air-Brake Swivel

absorption: regarding hose, the process of taking in fluid. Hose materials are often compared with regard to relative rates and total amounts of absorption as they pertain to specific fluids.

acid resistant: having the ability to withstand the action of identified acids within specified limits of concentration and temperature.

adapter, adaptor: 1) fittings of various sizes and materials used to change an end fitting from one type to another type or one size to another. (i.e., a male SAE to male pipe adapter is often attached to a female SAE to create a male end union fitting); 2) the grooved portion of a cam & groove coupling.

adhesion: the strength of bond between cured rubber surfaces or between a cured rubber surface and a non-rubber surface.

adhesive: a material which, when applied, will cause two surfaces to adhere.

ambient/atmospheric conditions: The surrounding conditions, such as temperature, pressure, and corrosion, to which a hose assembly is exposed.

anchor: a restraint applied to eliminate motion and restrain forces.

annular: refers to the convolutions on a hose that are a series of complete circles or rings located at right angles to the longitudinal axis of the hose (sometimes referred to as "bellows").

anodize, anodized: an electrolytic process used to deposit protective or cosmetic coatings in a variety of colors on metal, primarily used with aluminum.

ANSI: American National Standards Institute.

Application working pressure: unique to customer's application. See pressure, working.

armor: a protective cover slid over and affixed to a hose assembly; used to prevent over bending or for the purpose of protecting hose from severe external environmental conditions such as hot materials, abrasion or traffic.

assembly: a general term referring to any hose coupled with end fittings of any style attached to one or both ends.

ASTM: American Society for Testing and Materials.

axial movement: compression or elongation along the longitudinal axis.

B:

backing: a soft rubber layer between a hose tube and/or cover and carcass to provide adhesion.

barb: the portion of a fitting (coupling) that is inserted into the hose, usually comprised of two or more radial serrations or ridges designed to form a redundant seal between the hose and fitting.

barbed and ferrule fitting: a two-piece hose fitting comprised of a barbed insert (nipple), normally with peripheral ridges or backward-slanted barbs, for inserting into a hose and a ferrule, usually crimped or swaged.

Barb-Tite™: a line of low pressure push-on brass hose end fittings that is a Trademark of Dana Corporation.

bend radius: the radius of a bent section of hose measured to the innermost surface of the curved portion.

bend radius, minimum: the smallest radius at which hose or tubing can be used. For Metal Hose: the radius of a bend measured to the hose centerline, as recommended by the manufacturer.

blister: a raised area on the surface or a separation between layers usually creating a void or air-filled space in a vulcanized article.

body wire: normally a round or flat wire helix embedded in the hose wall to increase strength or to resist collapse.

bore: (1) an internal cylindrical passageway, as of a tube, hose or pipe; (2) the internal diameter of a tube, hose, or pipe.

braid: the woven portion of a hose used as reinforcement to increase pressure rating and add hoop strength. Various materials such as polyester, cotton or metal wire are used. A hose may have one or more braids, outside or between layers of hose material.

braided ply: a layer of braided reinforcement.

brand: a mark or symbol identifying or describing a product and/or manufacturer, that is embossed, inlaid or printed.

brass: a family of copper/zinc alloys.

brazing: a process of joining metals using a non-ferrous filler metal having a melting point that is lower than the "parent metals" to be joined, typically over +800°F.

bronze: an alloy of copper, tin and zinc.

BSPP/BSPT: British Standard Pipe Parallel / British Standard Pipe Tapered. See Fitting/Coupling - Pipe Thread Fittings.

C:

carcass: the fabric, cord and/or metal reinforcing section of a hose as distinguished from the hose tube or cover.

chalking: the formation of a powdery surface condition due to disintegration of surface binder or elastomer by weathering or other destructive environments.

checking: the short, shallow cracks on the surface of a rubber product resulting from damaging action of environmental conditions.

chemical compatibility: the relative degree to which a material may contact another without corrosion, degradation or adverse change of properties.

chemical resistance: the ability of a particular polymer, rubber compound, or metal to exhibit minimal physical and/or chemical property changes when in contact with one or more chemicals

for a specified length of time, at specified concentrations, pressure, and temperature.

cold flexibility: relative ease of bending while being exposed to specified low temperature.

collar: 1) the portion of a fitting that is compressed by crimping to seal the hose onto the fitting barbs and create a permanent attachment; also called a ferrule. (With field attachable fittings, the lock and seal are accomplished mechanically by the collar without crimping); 2) a raised portion on the hose shank which functions as a connection for a ferrule or other locking device or functions as a hose stop.

Coll-O-Crimp®: a line of hydraulic and pneumatic hose, hose end fittings, and fabrication equipment that is a registered trademark of Dana Corporation.

combustible liquid: a combustible liquid is one having a flash point at or above +100°F (37.8°C).

compound: the mixture of rubber or plastic and other materials, which are combined to give the desired properties when, used in the manufacture of a product.

compression fitting: see fitting/coupling - Compression

conductive: the ability to transfer electrical potential.

configuration: the combination of fittings on a particular assembly.

convoluted: description of hose or innercore having annular or helical ridges formed to enhance flexibility.

core: the inner portion of a hose, usually referring to the material in contact with the medium.

corrosion: the process of material degradation by chemical or electrochemical means.

corrosion resistance: ability of metal components to resist oxidation.

corrugated hose: hose with a carcass fluted, radially or helically, to enhance its flexibility or reduce its weight.

coupling: a frequently used alternative term for hose end fitting.

cover: the outer component usually intended to protect the carcass of a product.

CPE: chlorinated polyethylene, a rubber elastomer.

cracking: a sharp break or fissure in the surface, generally caused by strain and environmental conditions.

crimp diameter: the distance across opposite flats after crimping.

crimp/crimping: a hose end fitting attachment method utilizing a number of dies mounted in a radial configuration. The dies close perpendicular to the hose and fitting axis, compressing the collar, ferrule, or sleeve around the hose.

cure: the act of vulcanization. See vulcanization.

cut off factor: the hose length to be subtracted from the overall assembly length that allows for the hose coupling end connection extension beyond the end of the hose.

D:

date code: any combination of numbers, letters, symbols or other methods used by a manufacturer to identify the time of manufacture of a product.

deburr: to remove ragged edges from the inside diameter of a hose end.

design factor: a ratio used to establish the working pressure of the hose, based on the burst strength of the hose.

DOT: Department of Transportation.

DIN: Deutsche Industrie Norme.

duplex assembly: an assembly consisting of two hose assemblies—one inside the other, and connected at the ends; also known as “jacketed assemblies.”

durometer: an instrument for measuring the hardness of rubber and plastic compounds.

E:

eccentricity: the condition resulting from the inside and outside diameters not having a common center.

effusion: the escape, usually of gases, through a material. See permeation.

elastic limit: the limiting extent to which a body may be deformed and yet return to its original shape after removal of the deforming force.

elastomer: any one of a group of polymeric materials, usually designated thermoset, such as natural rubber, or thermoplastic, which will soften with application of heat.

elongation: the increase in length expressed numerically as a percentage of the initial length.

ERMETO™: a steel fitting product trademarked by Dana Corporation.

endurance test: a service or laboratory test, conducted to product failure, usually under normal use conditions.

EPDM: Ethylene Propylene Diene Monomer; an elastomer.

extrude/extruded/extrusion: forced through the shaping die of an extruder; extrusion may have a solid or hollow cross section.

F:

fabric impression: impression formed on the rubber surface during vulcanization by contact with fabric jacket or wrapper.

fabricator: the producer of hose assemblies.

fatigue: the weakening or deterioration of a material occurring when a repetitious or continuous application of stress causes strain, which could lead to failure.

FDA: United States Food and Drug Administration.

fire sleeve: slip-on or integrally extruded sleeve used to retard the effects of fire in certain applications; most often made with

silicone and/or ceramic fiber.

fitting/coupling: a device attached to the end of the hose to facilitate connection. The following is only a partial list of types of fittings available-

Compression Fitting - a fitting style that seals on a mating tube by compressing an internal ferrule against the tube O.D..

Field Attachable Fitting - a fitting designed to be attached to hose without crimping or swaging. This fitting is not always a reusable type fitting.

Flange Style Fittings - pipe flanges and flanged fitting standards are listed under ANSI B16.5. Flanges are rated for pressure and listed as "American Class 150, 300, 400, 600, 900, 1,500 or 2,500". Pressure-Temperature ratings can be obtained by consulting the ANSI specification or ASME B16.5 (American Society of Mechanical Engineers). Designs vary by neck and face style, or other dimensional changes based on use. Various finishes or grooves may be applied to the face for sealing on a gasket or o-ring. Bolt holes and other dimensions are per the ANSI standard.

Inverted Flare Fitting - a fitting consisting of a male or female nut, trapped on a tube by flaring the end of the tube material to either 37° or 45°.

JIC Fittings - joint Industrial Council (no longer in existence). An engineering group that established an industry standard fitting design incorporating a 37° mating surface, male and female styles. These standards are now governed by SAE.

O-ring Fittings - a fitting that seals by means of an elastomeric ring of a specified material.

Pipe Thread Fittings -

NPT - National Pipe Taper. Pipe thread per ANSI B1.20.1

NPTF - National Pipe Tapered for Fuels.
(Same as above except dry-seal per ANSI B1.20.3)

NPSH - National Pipe Straight Hose per ANSI B1.20.7

NPSM - National Pipe Straight Mechanical.
Straight thread per ANSI B1.20.1

NPSL - National Pipe Straight Loosefit per ANSI B1.20.1

BSPP, BSPT - British Standard Pipe Parallel, British Standard Pipe Taper. BS21

Quick Connect Fitting - a fitting designed to quickly connect and disconnect. These fittings come in many styles and types.

Split Flange Fitting - a fitting consisting of a flange retainer and a flange of two halves. This design allows the flanges to be installed after the retainer has been attached to the hose, making the flange reusable. SAE Code 61 and 62.

Tube Fitting - a hose fitting of which the mating end conforms to a tube diameter. The mate or male end of a compression fitting.

flammable gases/liquid/media: a flammable gas, including liquefied gas, is one having a closed cup flash point below +100°F (+37.8°C) and a vapor pressure greater than 25 psi. (174.2 KPa).

flex cracking: a surface cracking induced by repeated bending and straightening.

flow rate: a volume of media being conveyed in a given time period.

fluid: a gas or liquid medium.

fluorocarbon: an organic compound containing fluorine directly bonded to carbon. The ability of the carbon atom to form a large variety of structural chains gives rise to many fluorocarbons and fluorocarbon derivatives.

FOR-SEAL™: a product name for a hose end configuration using an o-ring sealing method, trademarked by Dana Corporation.

G:

GPM: gallons per minute.

H:

heat resistance: the property or ability to resist the deteriorating effects of elevated temperatures.

helix: a shape formed by spiraling a wire or other reinforcement around the cylindrical body of a hose; typically used in suction hose.

hose: a flexible conduit consisting of a tube, reinforcement, and usually an outer cover.

hydrostatic testing: the use of liquid pressure to test a hose or hose assembly for leakage, twisting, and/or hose change-in-length.

Hytrel®: a DuPont registered trademark.

I:

I.D.: the abbreviation for inside diameter.

identification yarn: a yarn of single or multiple colors, usually embedded in the hose wall, used to identify the manufacturer.

impression: a design formed during vulcanization in the surface of a hose by a method of transfer, such as fabric impression or molded impression.

impulse: an application of force in a manner to produce sudden strain or motion, such as hydraulic pressure applied in a hose.

innertube: the innermost layer of a hose; the hose material in contact with the medium.

insert: optional term for nipple. See nipple.

interlocking clamp: a clamp which engages the fitting in a manner which prevents the clamp from sliding off the fitting, typically

a bolt or U-bolt style with interlocking fingers which engage an interlock ring on the fitting.

interlocking ferrule: a ferrule, which physically attaches to the fitting preventing the ferrule from sliding off the fitting.

ISO: International Organization for Standardization.

J:

jacket: a seamless tubular braided or woven ply generally on the outside of a hose.

JIC: see fitting/coupling-JIC.

K:

kinking: a temporary or permanent distortion of the hose induced by bending beyond the minimum bend radius.

L:

layline: the line of printed information that runs parallel on the side of a manufactured hose giving details such as part number, PSI rating, hose size and manufacturing data.

layer: a single thickness of rubber or fabric between adjacent parts.

loop installation: the assembly is installed in a loop or "U" shape, and is most often used when frequent and/or large amounts of motion are involved.

LPG, LP Gas: the abbreviation for liquefied petroleum gas.

M:

MAWP: see pressure, maximum allowable working.

manufacturer's identification: a code symbol used on or in some hose to indicate the manufacturer.

media, medium: the substance(s) being conveyed through a system.

N:

NAHAD: the abbreviation for the National Association of Hose & Accessories Distributors.

Neoprene®: a registered trademark of DuPont.

nipple: the internal member or portion of a hose fitting.

nitrile rubber (NB/Buna-N): a family of acrylonitrile elastomers used extensively for industrial hose.

nominal: a size indicator for reference only.

nomograph: a chart used to compare hose size to flow rate to recommended velocity.

non-conductive: the inability to transfer an electrical charge.

NPT/NPTF: abbreviation for national pipe threads. See fitting/coupling - Pipe Thread Fittings.

nylon: a family of polyamide materials.

O:

OAL: see overall length

O.D.: the abbreviation for outside diameter.

OE/OEM: original equipment manufacturer.

oil resistance: the ability of the materials to withstand exposure to oil.

oil swell: the change in volume of a rubber article resulting from contact with oil.

operating conditions: the pressure, temperature, motion, and environment to which a hose assembly is subjected.

o-ring fitting: see fitting/coupling, O-Ring.

overall length (OAL): the total length of a hose assembly, which consists of the free hose length plus the length of the coupling(s).

oxidation: the reaction of oxygen on a material, usually evidenced by a change in the appearance or feel of the surface or by a change in physical properties.

ozone cracking: the surface cracks, checks or crazing caused by exposure to an atmosphere containing ozone.

ozone resistance: the ability to withstand the deteriorating effects of ozone (generally cracking).

P:

permanent fitting: the type of fitting which, once installed, may not be removed for re-use.

permeation: the process of migration of a substance into and through another, usually the movement of a gas into and through a hose material; the rate of permeation is specific to the substance, temperature, pressure and the material being permeated.

pin pricked: perforations through the cover of a hose to vent permeating gases.

pitch: 1) the distance from one point on a helix to the corresponding point on the next turn of the helix, measured parallel to the axis; 2) the distance between the two peaks of adjacent corrugation or convolution.

plating: a material, usually metal, applied to another metal by electroplating, for the purpose of reducing corrosion; typically a more noble metal such as zinc is applied to steel.

ply: an individual layer in hose construction.

polymer: a macromolecular material formed by the chemical combination of monomers, having either the same or different chemical compositions.

pressure: force ÷ unit area. For purposes of this document, refers to PSIG (pounds per square inch gauge).

pressure drop: the measure of pressure reduction or loss over a specific length of hose.

pressure, burst: the pressure at which rupture occurs.

pressure, maximum allowable working: the maximum pressure at which a hose or hose assembly is designed to be used.

pressure, working: the maximum pressure to which a hose will be subjected, including the momentary surges in pressure, which can occur during service. Abbreviated as WP.

psi (PSI): pounds per square inch.

PTFE: polytetrafluoroethylene, a high molecular weight fluoroplastic polymer with carbon atoms shielded by fluorine atoms having very strong inter atomic bonds, giving it chemical inertness.

Push > Connect™: (Push > Connect™ Metric, Push > Connect™ Flow Controls, Push > Connect™ Plus) A Reusable, easy to assemble fitting recommended on compressed air, lubrication, and pneumatic instrumentation applications. Use with approved tubing material.

PVC: polyvinyl chloride. A low cost thermoplastic material typically used in the manufacture of industrial hoses. The operating temperature range is -500°F to +1750°F (-295.5°C to +954.4°C).

Q:

Quick > Connect™: A reusable easy to assemble air brake fitting used on NT100 series tubing. This fitting meets D.O.T. performance requirements.

R:

reinforcement: the strengthening members, consisting of either fabric, cord, and/or metal, of a hose. See ply.

reusable fitting/coupling: see fitting/coupling, Field Attachable Fittings.

RhinoHide®: a product's name for an abrasion resistant covered hydraulic hose that is a registered trademark of Dana Corporation.

RMA: The Rubber Manufacturers Association, Inc.

S:

SAE: Society of Automotive Engineers.

shank: that portion of a fitting, which is inserted into the bore of a hose.

skive: the removal of a short length of cover and/or tube to permit the attachment of a fitting directly over the hose reinforcement.

sleeve: a metal cylinder, which is not physically attached to the fitting, for the purpose of forcing the hose into the serrations of the fitting.

smooth bore: a term used to describe the type of innercore in a hose.

specification: a document setting forth pertinent details of a product.

spiral: a method of applying reinforcement in which there is not interlacing between individual strands of the reinforcement.

spring guard: a helically wound component applied internally or externally to a hose assembly, used for strain relief, abrasion resistance, collapse resistance.

standard: a document, or an object for physical comparison, for defining product characteristics, products, or processes, prepared by a consensus of a properly constituted group of those substantially affected and having the qualifications to prepare the standard for use.

static wire: wire incorporated in a hose to conduct static electricity.

stem: see nipple.

surge (spike): a rapid and transient rise in pressure.

swelling: an increase in volume or linear dimension of a specimen immersed in liquid or exposed to a vapor.

T:

Teflon®: a registered trademark of E.I. DuPont. See PTFE, FEP and PFA.

tube: the innermost continuous all-rubber or plastic element of a hose.

tube fitting: see fitting/coupling-Tube.

tubing: a non-reinforced, homogeneous conduit, generally of circular cross-section.

V:

vacuum resistance: the measure of a hoses ability to resist negative gauge pressure.

vibration: amplitude motion occurring at a given frequency.

viscosity: the resistance of a material to flow.

vulcanization: a process during which a rubber compound, through a change in its chemical structure, improves or extends elastic properties over a greater range of temperature.

W:

weathering: the surface deterioration of a hose cover during outdoor exposure, as shown by checking, cracking, crazing and chalking.

wire reinforced: a hose containing wires to give added strength, increased dimensional stability; crush resistance. See reinforcement.

working temperature: the temperature range of the application, may include the temperature of the fluid conveyed or the environmental conditions the assembly is exposed to in use.

WP: the abbreviation for working pressure.

The preceding Glossary of Terms, as utilized in the hose industry, includes some definitions from The Hose Handbook, published by the Rubber Manufacturers Association.

A55SCUx.....	76	BA-56X.....	240	C5755x.....	180
A555.....	111	BA-84.....	239	C5880x.....	171
A555P.....	113	BA-84X.....	239	C5924x.....	167
A555S.....	111	BF-40.....	236	C9200.....	125
A556P.....	113	BF-40X.....	235, 235, 236, 237, 242	C9240.....	125
A557MCUx.....	76	BF-41.....	236	C-5X.....	248
A557SCUx.....	76	BF-42.....	237	C-15X.....	231, 232
A655.....	111	BF-43.....	237	C-63X.....	231, 232, 234, 241, 248
A655S.....	111	BL-456.....	247	C-632X.....	232, 232, 233
A660.....	111	BL-456X.....	244, 246	CA-10X.....	245
A664.....	119	C3059x.....	140	CA-130.....	245
A690.....	111	C3069x.....	142	CA-230.....	245
A690P.....	113	C3109x.....	141	CA-631.....	234
A690S.....	111	C3159x.....	140	CA-631CO.....	234
A694.....	119	C3169x.....	140	CA-632.....	232, 233
A694S.....	119	C3179x.....	140	CA-632CO.....	233
A735.....	111	C3209x.....	141	CB-63X.....	231, 232, 234
A6690.....	111	C3239x.....	142, 186	CD-15.....	231, 232
A6690S.....	111	C3249x.....	142, 184	CD-15D.....	231
A6754.....	119	C3269x.....	141, 184	CL-16-1.....	230, 234
A6754S.....	119	C3309x.....	142	CL-16-2.....	230, 243
A6755.....	111	C3359x.....	143	CL-16-3.....	91, 230, 241
A6755S.....	111	C3409x.....	144	CL-434.....	230, 249
A6759.....	119	C3459x.....	145, 192	CL-490.....	37, 42, 48, 104, 230, 233, 234
A6760.....	111	C3469x.....	145, 193	CL-491.....	97, 230
A6760P.....	113	C3509x.....	144	CL-492.....	230
A6760S.....	111	C3529x.....	146	CL-493.....	230
A6763.....	111	C3559x.....	143	CL-494.....	230
A6763S.....	111	C3609x.....	146	CL-496.....	79, 230
A6764.....	119	C3709x.....	146	CL-497.....	230, 241
A6764S.....	119	C3759x.....	147	CL-498.....	60, 230
A6765.....	111	C3959x.....	147	CL-499.....	65, 230, 238
A6765S.....	111	C5015x.....	167	CL-500.....	54, 230
A6769.....	119	C5105x.....	166	CL-501.....	230
A6769S.....	119	C5115x.....	166	CL-502.....	230, 248
A6770.....	111	C5125x.....	166	CL-503.....	83, 230, 242
A6774.....	119	C5129x.....	167	DC-121.....	238
A6775.....	111	C5165x.....	166, 184	FA-100.....	247
A6775S.....	111	C5165x-MM.....	166, 213, 248	FA-100-CO.....	247
A6779.....	119	C5205x.....	169	FC-16X.....	231, 234, 238, 241, 242, 243
A6779S.....	119	C5216x.....	172, 188	FC-161.....	234
A6793.....	118	C5229x.....	167	FH-15X.....	231, 243, 247, 249
A6845.....	111	C5255x.....	169	FL-310.....	249
A6845S.....	111	C5256x.....	172	FL-310X.....	249
A6855.....	111	C5275x.....	169	FS-100.....	230
A6855S.....	111	C5305x.....	168	FS-200.....	164, 230
A6860.....	111	C5306x.....	168	FS-300.....	208, 209, 230
A6860P.....	113	C5314x.....	184	FS-500.....	230
A6860S.....	111	C5315x.....	170, 187	FS-501.....	230, 246
AB-8.....	245	C5316x.....	170, 187	FS-800.....	97, 230, 243
AB-8L.....	245	C5325x.....	168	FS-900.....	91, 230
AB-8X.....	245	C5355x.....	172	FS-1000.....	79, 230
AB-9.....	245	C5356x.....	173	FS-1600.....	195, 230
AB-9L.....	245	C5365x.....	174, 188	FS-2000.....	139, 230
AB-9X.....	245	C5405x.....	175	FS-2100.....	60, 230
AB-28.....	243	C5425x.....	176	FS-2400.....	154, 230
AB-45.....	243	C5455x.....	177	FS-2500.....	249
AB-140.....	241	C5505x.....	174	FS-3300.....	83, 230
AB-1400.....	241	C5506x.....	177	FS-SA-2.....	244
B735.....	111	C5515x.....	178, 190	H05703.....	246
BA-24.....	240	C5525x.....	176	H05704.....	246, 249
BA-24X.....	240	C5605x.....	181	H05705.....	246, 249
BA-28.....	240	C5655x.....	182	H05706.....	246, 249
BA-28X.....	240	C5705x.....	179	H06904.....	247
BA-38.....	240	C5706x.....	180	H06906.....	247
BA-38X.....	240	C5707x.....	182	H06908.....	247
BA-48.....	240	C5715x.....	183, 193	H06910.....	247
BA-48X.....	240	C5716x.....	181, 193	H10104.....	247
BA-56.....	240	C5726x.....	181	H10105.....	246

H10106.....	246	PT24006.....	34	SJ312.....	128, 240
H16606.....	247	PT24008.....	34	SJ320.....	128, 240
H16608.....	247	PT24010.....	34	SJ330.....	128, 240
H33806.....	247	PT24012.....	34	SJ340.....	128, 240
HA-574.....	246	PT24016.....	34	SJ351.....	128, 240
HC-574X.....	246	QC-18.....	242	SJ360.....	128, 240
HD-1X.....	247	QC-18X.....	242	SS-85.....	235
M7629x.....	214, 248	QC-180.....	242	SS-86.....	235
M7630x.....	214	QC-1800.....	242	SS-87.....	235
M9600x.....	217, 248	RG-24.....	223	SS-88.....	236
M9700x.....	214, 248	S306.....	128, 223, 239	T-100.....	227
M9800x.....	217, 248	S308.....	128, 239	T-104.....	227
M41157x.....	124	S310.....	128	T-105.....	227
MA-100.....	248	S312.....	128, 239, 240	T-106.....	227
MA-200.....	249	S320.....	128, 239, 240	T-107.....	227
MB5315x.....	217, 248	S330.....	128, 239, 240	T-108.....	227
MB5515x.....	218, 248	S340.....	128, 239, 240	T-125B.....	226
MB7629x.....	218	S351.....	128, 239, 240	T-135.....	226
MB7630x.....	218	S360.....	128, 239, 240	T-135B.....	226
MC3069x.....	216	S372.....	128, 239	T-138.....	226
MC3159x.....	215	S408.....	128	T-138B.....	226
MC3309x.....	215	S412.....	128, 239, 240	T-139.....	225
MC5019x.....	171, 212	S420.....	128, 239, 240	T-139P.....	225
MC5205x.....	216, 248	S430.....	128, 239, 240	T-140.....	225
MC5206x.....	212, 248	S440.....	128, 239, 240	T-141.....	225
MC5207x.....	212, 248	S451.....	128, 239, 240	T-142.....	225
MC5208x.....	212, 248	S460.....	128, 239, 240	T-143.....	225
MC5315x.....	213, 248	S512.....	128, 239, 240	T-144.....	225
MC5405x.....	218, 248	S520.....	128, 239, 240	T-145.....	225
MC5515x.....	214, 248	S530.....	128, 239, 240	T-146.....	225
MH7105x.....	211, 248, 249	S540.....	128, 239, 240	T-147.....	225
ML7105x.....	211, 248, 249	S551.....	128, 239, 240	T-148.....	225
MTP16004.....	35	S560.....	128, 239, 240	T-149.....	225
MTP16005.....	35	S612.....	128, 240	T-150.....	225, 228
MTP16006.....	35	S620.....	128, 240	T-151.....	225
MTP16008.....	35	S630.....	128, 240	T-152.....	225
MTP16010.....	35	S640.....	128, 240	T-152P.....	225
MTP16012.....	35	S651.....	128, 240	T-191.....	226, 242
NT10002.....	33, 244	S660.....	128, 240	T-191B.....	226
NT10025.....	33	SA-1.....	244	T-200.....	227
NT10003.....	33	SA-2.....	244	T-210.....	228
NT10004.....	33, 244	SB308.....	128, 240	T-220.....	228
NT10005.....	33	SB312.....	128, 240	T-221.....	228
NT10006.....	33, 244	SB320.....	128, 240	T-345.....	228
NT10008.....	33	SB330.....	128, 240	T-345K.....	228
NT10010.....	33	SB340.....	128, 240	T-346x.....	228
NT10012.....	33	SB351.....	128, 240	T-372.....	227
PC-48.....	238	SB360.....	128, 240	T-373.....	227
PD-15.....	231	SC308.....	128, 240	T-374.....	227
PD-49.....	231, 232, 248	SC312.....	128, 240	T-375.....	227
PD-75.....	231, 232, 248	SC320.....	128, 240	T-376.....	227
PD-95.....	231	SC330.....	128, 240	T-378.....	227
PT20004.....	33	SC340.....	128, 240	T-450-3.....	222
PT20044.....	33	SC351.....	128, 240	T-460-2.....	222
PT20005.....	33	SC360.....	128, 240	T-560.....	230
PT20006.....	33	SFK-8.....	208	T-560-1.....	230
PT20008.....	33	SFK-12.....	208	T-560-2.....	230
PT20010.....	33	SFK-16.....	208	T-560-3.....	230
PT20012.....	33	SFK-20.....	208	T-560-4.....	230
PT20016.....	33	SFK-24.....	208	T-560-5.....	230
PT23002.....	34	SFK-32.....	208	T-560-6.....	230
PT23003.....	34	SFK62-8.....	209	T-560-7.....	230
PT23004.....	34	SFK62-12.....	209	T-560-8.....	230
PT23005.....	34	SFK62-16.....	209	T-562.....	229
PT23006.....	34	SFK62-20.....	209	T-570.....	222
PT23008.....	34	SFK62-24.....	209	T-570-1.....	222
PT24004.....	34	SFK62-32.....	209	T-570-4.....	222
PT24044.....	34	SH-53.....	230	T-570-6.....	222
PT24005.....	34	SJ308.....	128, 240	T-570-8.....	222

T-570-12.....	222	TF3959x.....	147	10U.....	249
T-570-16.....	222	TF5355x.....	172	12U.....	249
T-571-4.....	222	TF5356x.....	173	16U.....	249
T-571-6.....	222	TF5365x.....	174, 188	05703B-102.....	233
T-571-8.....	222	TF5375x.....	173	05704B-102.....	233, 249
T-571-12.....	222	TF5405x.....	175	05704B-104.....	233, 249
T-571-16.....	222	TF5406x.....	178	05704B-C02.....	233, 249
T-1010.....	227	TF5425x.....	176	05705B-102.....	233, 249
T-1022.....	228	TF5435x.....	176	05705B-104.....	233, 249
T-1037.....	226	TF5455x.....	177	05705B-C02.....	233, 249
T-1037B.....	226	TF5505x.....	174	05705B-C04.....	233, 249
T-1037H.....	226	TF5506x.....	177	05705B-1560.....	233, 249
T-1290.....	228	TF5515x.....	178, 190	05705B-1561.....	233, 249
T-1295.....	229	TF5515x-L.....	179, 190	05706B-102.....	233, 249
T-1422R.....	225, 228	TF5515x-LL.....	179, 191	05706B-104.....	233, 249
T-1430.....	225	TF5525x.....	176	05706B-106.....	233, 249
T-3710.....	227	TF5605x.....	181	05706B-C02.....	233, 249
T-3712.....	227	TF5655x.....	182	05706B-C04.....	233, 249
T-3716.....	227	TF5705x.....	179	05706B-1568.....	233, 249
T-5002.....	223	TF5706x.....	180	05706B-1570.....	233, 249
T-5003.....	223	TF5707x.....	182	05710B-106.....	121
T-5004.....	223	TF5715x.....	183, 193	05710B-108.....	121
T-5005.....	223	TF5716x.....	181, 193	05710B-C06.....	124
T-5006.....	223	TF5725x.....	182	05712B-108.....	121
T-5008.....	223	TF5726x.....	181	5X6 PB.....	230
T-5010.....	223	TF5755x.....	180	6X10 PB.....	230
T-5012.....	223	TF5805x.....	180	8X12 PB.....	230
T-5016.....	223	TF5955x.....	183	8x251.....	208
T-5020.....	223	TH7008.....	222	8x252.....	208, 209, 223
T-5024.....	223	TH7010.....	222	8x254.....	208, 209
T-5032.....	223	TH7012.....	222	8x262.....	209
T-5102.....	223	TH7014.....	222	8x853.....	208
T-5103.....	223	TH7016.....	222	8x863.....	209
T-5104.....	223	TH7020.....	222	12x251.....	208
T-5105.....	223	TH7025.....	222	12x252.....	208, 209, 223
T-5106.....	223	TH7030.....	222	12x254.....	208, 209
T-5108.....	223	TL7008.....	222	12x262.....	209
T-5110.....	223	TL7010.....	222	12x853.....	208
T-5112.....	223	TL7012.....	222	12x863.....	209
T-5116.....	223	TL7015.....	222	16x251.....	208
T-5120.....	223	TL7018.....	222	16x252.....	208, 209, 223
T-5124.....	223	TL7022.....	222	16x254.....	208, 209
T-5132.....	223	TL7028.....	222	16x262.....	209
T-7002.....	222	TP16002.....	35	16x853.....	208
T-7003.....	222	TP16025.....	35	16x863.....	209
T-7004.....	222	TP16004.....	35	20x251.....	208
T-7005.....	222	TP16005.....	35	20x252.....	208, 209, 223
T-7006.....	222	TP16006.....	35	20x254.....	208, 209
T-7008.....	222	TP16008.....	35	20x262.....	209
T-7010.....	222	W05465.....	143, 243	20x853.....	208
T-7012.....	222	W05498.....	143	20x863.....	209
T-7014.....	222	W05499.....	143	24x251.....	208
T-7016.....	222	W05730.....	143	24x252.....	208, 209, 223
T-7020.....	222	W1206.....	219	24x254.....	208
T-7024.....	222	W1212.....	219	24x262.....	209
T-7032.....	222	W1512.....	219	24x264.....	209
TA-1002.....	224, 248	W14630.....	219, 243	24x853.....	208
TA-1004.....	224	W15310.....	101, 118, 241, 243	24x863.....	209
TF3359x.....	143	W17709.....	143	32x251.....	208
TF3409x.....	144	W20332.....	101, 119	32x252.....	208, 209, 223
TF3459x.....	145, 192	W21204.....	143	32x262.....	209
TF3509x.....	144	W23464.....	143	32x264.....	209
TF3529x.....	146	W76150.....	219, 243	32x863.....	209
TF3559x.....	143	W79850.....	219, 243	39x.....	43
TF3569x.....	145, 189	W79851.....	219, 243	40x.....	43
TF3609x.....	146	W-8022.....	37, 42, 48, 104, 230	41x.....	43, 233, 234
TF3709x.....	146	04U.....	249	42x.....	43, 233
TF3759x.....	147	06U.....	249	43x.....	44
TF3805x.....	147	08U.....	249	44x.....	47

45x.....	47	252x.....	39, 233	1161x.....	66
46x.....	44	270.....	114, 233	1161x-M.....	71
48x.....	44, 233, 234	302x.....	38, 128, 233, 234, 235, 236, 237	1162x.....	67, 238
49x.....	46, 233, 234	320.....	113	1162x-M.....	71
50x.....	46	325.....	113	1164x.....	69, 238
51x.....	47	330.....	113	1164x-M.....	73
54x.....	44	352x.....	39	1165x.....	68, 238
55x.....	45	402x.....	40, 233, 234, 235	1165x-M.....	73
56x.....	47	452x.....	40	1166x.....	68, 238
59x4.....	125	502x.....	40	1166x-M.....	72
60x.....	49, 233, 234, 235	530.....	113	1168Px.....	77
61x.....	49, 233, 234, 235	537.....	119	1168x.....	68, 238
62x.....	50, 233, 234, 235	601x.....	56, 244	1168x-M.....	72
63x.....	51	602x.....	41	1169Px.....	78
64x.....	53, 233	611x.....	56, 244	1169x.....	69
65x.....	52	621x.....	57, 244	1169x-M.....	73
66x.....	51, 233	630.....	113	1169x-MS.....	73
68x.....	50, 233, 234, 235	632.....	119	1169x-S.....	69, 238
69x.....	52, 233, 234, 235	631x.....	57	1171Px.....	78
70x.....	52	641x.....	59	1171x-M.....	74
71x.....	53	651x.....	58	1171x-S.....	69, 238
72x.....	53	652x.....	41	1172Px.....	78
74x.....	50, 51	661x.....	57, 244	1172x-M.....	74
76x.....	53	681x.....	57, 244	1172x-S.....	70, 238
100x.....	38, 233	691x.....	58, 244	1174x.....	67, 238
105x.....	38, 111, 126, 233, 234, 235, 236, 237	695.....	113	1174x-M.....	71
108.....	114	700.....	113	1180x.....	67
110.....	117, 238	701x.....	58	1180x-M.....	71
111.....	117, 238	702.....	119	1181x.....	70
112.....	117, 238	702x.....	41	1182x.....	70
113.....	117, 238	703.....	119	1183x.....	70
114.....	117, 238	705.....	115	1184x.....	70
115.....	117, 238	711x.....	59	1185x.....	70
116.....	117, 238	721x.....	59	1202x.....	62
117.....	117, 238	741x.....	56, 58	1260x.....	61
118.....	117	752x.....	41	1260x-B.....	61
119.....	117	0102x.....	50, 56	1261x.....	61
120.....	115	1062x.....	80	1261x-A.....	61
121.....	117	1064x.....	82	1261x-B.....	62
122.....	117	1065x.....	81	1262x.....	62
123.....	117	1066x.....	80	1264x.....	64
124.....	117	1067x.....	81	1266x.....	63
125.....	117	1068x.....	80	1268x.....	62
126.....	117	1069x.....	81	1269x.....	63
127.....	117	1070x.....	81	1270x.....	63
128.....	117	1071x.....	82	1271x.....	64
130.....	114	1072x.....	82	1272x.....	64
131x.....	38, 233, 234	1073x.....	80	1274x.....	62, 63
135.....	114, 233, 234, 238	1074.....	126	1340.....	101, 108
140.....	114, 233	1074x.....	81	1341.....	101, 108
145.....	101, 114, 233, 234, 238, 241, 243	1075x.....	82	1342.....	101, 108
150.....	115	1077x.....	82	1343.....	101, 108
162x.....	50	1078x.....	80	1344.....	101, 108
163x.....	51	1079x.....	80	1345.....	101, 108
164x.....	53	1100x-MM.....	217	1346.....	101, 108
165x.....	52	1100x-PP.....	217	1351.....	101, 108
166x.....	51	1105x.....	66	1360x.....	98, 243
168x.....	50	1105x-M.....	71	1361x.....	98, 243
169x.....	52	1107x.....	67	1362x.....	98, 243
170x.....	52	1107x-M.....	72	1364x.....	100
171x.....	53	1108Px.....	77	1365x.....	99
172x.....	53	1108x-S.....	68	1366x.....	99
174x.....	51	1108x-M.....	72	1368x.....	98, 243
176x.....	53	1109x.....	66	1369x.....	99, 243
185.....	114	1109x-M.....	71	1369x-L.....	99
190.....	114	1110x.....	43	1370x.....	100
202x.....	39, 233, 234, 235	1129x.....	66	1371x.....	100
230.....	114	1129x-MRP.....	71	1372x.....	100
		1150x-PP.....	216	1380x.....	99

1382x.....	100	1563.....	39, 45, 123	1914.....	137
1408.....	121	1564x.....	134	1915.....	137
1410.....	121	1564Px.....	134	1916.....	137
1421-7.....	116	1565x.....	134	1917.....	137
1421-18.....	116	1565Px.....	134	1918.....	137
1421-24.....	116	1566x.....	132	1920.....	137
1421-32.....	116	1566Px.....	132	1921.....	137
1421-60.....	116	1568x.....	131	1922.....	137
1421-60A.....	116	1568Px.....	131	1923.....	137
1422.....	116	1569x.....	133	1924.....	137
1423.....	116	1569Px.....	133	1925.....	137
1424A.....	115	1570x.....	133	1927.....	137
1425A.....	115	1570Px.....	133	1928.....	137
1426A.....	115	1571x.....	135	1929.....	137
1427.....	116	1571Px.....	135	1930.....	137
1428.....	121	1572x.....	134	1931.....	137
1429.....	121	1572Px.....	134	1932.....	137
1432.....	121	1574x.....	131	1933.....	137
1433.....	116	1574Px.....	131	1935.....	137
1437.....	122	1584x.....	135	1936.....	137
1439.....	122	1584Px.....	135	1937.....	137
1440.....	122	1596.....	123	1938.....	137
1441.....	126	1597.....	123	1939.....	137
1442.....	127, 233	1611x.....	50, 56	1940.....	137
1443.....	127, 233	1621x.....	57	1942.....	137
1444.....	122	1631x.....	57	1943.....	137
1445.....	122	1641x.....	59	1944.....	137
1446.....	122	1651x.....	58	1945.....	137
1447.....	122	1661x.....	57	1946.....	137
1451.....	116	1681x.....	57	1948.....	137
1460x.....	92, 241, 241, 244	1691x.....	58	1949.....	137
1461x.....	92, 241, 241, 244	1701x.....	58	1950.....	137
1462x.....	92, 241, 241, 244	1711x.....	59	2030x.....	49, 56, 233
1464x.....	95, 241, 244	1721x.....	59	3081x.....	142
1465x.....	94	1741x.....	58	3121x.....	141
1466x.....	93, 241, 244	1800Kx.....	90, 242	3129x.....	105, 233
1468x.....	93, 241, 241, 244	1800T.....	90, 242	3150x.....	105, 233, 234
1469x.....	94, 241, 241, 244	1800TRK.....	90, 242	3151x.....	105, 233, 234, 235
1469x-L.....	94	1829x.....	90	3152x.....	105, 233, 234, 236
1470x.....	94	1861x.....	85	3153x.....	105
1471x.....	95, 241	1862x.....	85, 242	3171x.....	140
1472x.....	95, 241, 244	1864x.....	88	3200x.....	105, 233, 234
1474x.....	93	1865x.....	87	3220x.....	106, 233, 234, 235, 236
1477x.....	95	1866x.....	86	3221x.....	141
1480x.....	93, 241	1868x.....	86, 242	3250x.....	106
1482x.....	96	1869x.....	87, 242	3300x.....	106, 233, 234, 235, 236
1484x.....	96, 241, 241, 244	1869x-L.....	87	3321x.....	142
1485x.....	96, 244	1869x-S.....	88	3325x.....	107, 233, 234
1502x.....	136	1870x.....	88	3326x.....	107, 233, 234, 236
1502Px.....	136	1871x.....	89	3327x.....	107, 233, 234
1512.....	106, 122	1871x-S.....	89	3328x.....	107, 233, 234
1513.....	123, 125	1872x.....	89	3329x.....	107
1514.....	40, 106, 123, 233	1872x-S.....	90	3330x.....	107
1518.....	39, 45, 123	1873x.....	85	3331x.....	107
1521.....	45, 123	1874x.....	85, 242	3350x.....	108, 233, 234, 236
1522.....	39, 45, 123	1877x.....	90	3371x.....	143
1529x.....	136	1880x.....	86, 242	3400x.....	108, 233, 234, 236
1529Px.....	136	1880x-S.....	87	3421x.....	144
1531x.....	136	1883x.....	90	3500x.....	109, 233, 236
1538.....	233	1900.....	137	3521x.....	144
1539.....	233	1901.....	137	3541x.....	146
1540.....	233	1902.....	137	3600x.....	109, 233
1548.....	221, 233	1903.....	137	3621x.....	146
1553.....	39, 45, 123	1906.....	137	3700x.....	109, 233, 234
1554.....	39, 45, 123	1907.....	137	3721x.....	146
1561x.....	135	1908.....	137	3750x.....	109, 233, 235
1561Px.....	135	1911.....	137	3771x.....	147
1562x.....	132	1912.....	137	3950x.....	109
1562Px.....	132	1913.....	137	4105x.....	157

4129x.....	157	6206-004.....	245	7504.....	117
4165x.....	157	6206-006.....	245	7505x.....	204
4205x.....	142, 159	6300x.....	103	7506.....	117
4213x.....	159, 170	6400x.....	103	7508.....	117
4229x.....	158	6600.....	116	7509.....	117
4305x.....	158	6660.....	115, 233	7515x.....	192, 205
4307x.....	199	6700.....	113	7517x.....	204
4315x.....	158, 184	6703.....	113	7527x.....	205
4316x.....	159, 186	6707.....	120	7605x.....	206
4325x.....	158	6708.....	120	7617x.....	206
4355x.....	160	6709.....	120	7629x.....	138, 147, 171, 183, 194, 207, 223
4365x.....	160, 189	6715.....	112	7655x.....	206
4375x.....	160	6719.....	118	7667x.....	206
4405x.....	161	6724.....	118	7709.....	127
4505x.....	160	6729.....	118	7705x.....	205
4515x.....	161	6737.....	120	7715x.....	194, 207
4525x.....	161	6746.....	120	7716x.....	193, 206
4535x.....	162, 191	6747.....	120	7717x.....	205
4629x.....	138, 163, 223	6748.....	120	7727.....	126, 194
4640x.....	157	6749.....	120, 233	7727x.....	207
4705x.....	162	6783.....	115	7728x.....	206
4715x.....	162, 191, 194	6788.....	114	7732.....	126
4716x.....	163, 194	6800.....	112	7755x.....	205
4726x.....	163	6804.....	120	7765.....	127
4924x.....	157	6805.....	112	7767x.....	205
4955x.....	163	6809.....	120, 233	7771.....	126
5027x.....	167	6810.....	112	7805.....	127
5117x.....	166	6815.....	112	7805x.....	205
5141x.....	167	6820.....	112	7812.....	127
5177x.....	166	6824.....	119	7817.....	126
5188.....	127	6825.....	112	7818.....	126, 233, 236
5217x.....	169	6828.....	120	7828.....	126, 233, 236
5241x.....	167	6829.....	119, 233	7829.....	126, 233, 236
5267x.....	169	6891.....	118	7896x.....	38, 126, 233, 235, 236, 237
5317x.....	168	6892.....	118, 233	7897.....	126, 236
5318x.....	168	6893.....	118	7898.....	127, 236, 237
5327x.....	170, 187	7015x.....	202	7900.....	127, 236, 237
5337x.....	168	7027x.....	202	7901.....	127, 236, 237
5367x.....	172	7033x.....	184	7904.....	127, 233, 236, 237
5368x.....	173	7105x.....	201	7905.....	127, 236, 237
5417x.....	175	7117x.....	201	7906.....	127, 233, 236, 237
5467x.....	177	7129x.....	202	7908.....	126, 233, 236
5517x.....	174	7141x.....	202	7909.....	126
5518x.....	177	7165x.....	201	7910.....	126, 236
5527x.....	178, 190	7165x-MM.....	211, 248, 249	7911.....	126, 236
5537x.....	176	7176x.....	201	7912.....	126, 236
5617x.....	181	7205x.....	203	7913.....	126, 236
5667x.....	182	7217x.....	203	7914.....	127, 233, 236, 237
5717x.....	179	7229x.....	202	7915.....	125, 126
5718x.....	180	7237x.....	184	7916.....	125, 126
5719x.....	182	7238x.....	184	7917.....	126, 236
5737x.....	182	7241x.....	202	7921.....	237
5767x.....	180	7255x.....	203	7924x.....	201
5967x.....	183	7267x.....	203	7933.....	127, 236, 237
6100x.....	103, 125, 233	7305x.....	202	7934A.....	128, 233, 237
6200x.....	103, 233	7306x.....	202	7935.....	127, 233, 237
6202.....	233	7315x.....	186, 203	7936.....	127, 233, 237
6203-010.....	245	7317x.....	202	7936x.....	167, 201
6203-016.....	245	7318x.....	202	7937.....	127, 233, 237
6203-020.....	245	7325x.....	203	7940.....	128, 233, 237
6203-024.....	245	7327x.....	186, 203	7941.....	128, 233, 237
6203-036.....	245	7337x.....	203	7955x.....	207
6204-010.....	245	7355x.....	204	7967x.....	207
6204-016.....	245	7367x.....	204	7970.....	127, 237
6204-020.....	245	7405x.....	204	7972.....	237
6204-024.....	245	7417x.....	204	7974.....	237
6204-036.....	245	7455x.....	204	7975.....	127, 237
6205-004.....	245	7467x.....	204	7977.....	124
6205-006.....	245	7502.....	117	7978.....	124

8112x.....	201	24706N-606.....	247	60012.....	209
8165x.....	201	24706N-608.....	247	60016.....	209
8367.....	221	24706N-756.....	247	60020.....	209
8370.....	220, 221	24706N-B06.....	247	60024.....	209
8371.....	220, 221	24708N-106.....	247	60032.....	209
8372.....	220, 221	24808N-108.....	247	64508.....	209
8373.....	220, 221	24808N-406.....	247	64512.....	209
8374.....	220, 221	24808N-608.....	247	64516.....	209
8375.....	221	24710B-Y58.....	247	64520.....	209
8376.....	221	24710B-Y60.....	247	64524.....	209
8377.....	221	24710N-108.....	247	64532.....	209
8378.....	221	24710N-608.....	247	69008.....	209
9100x.....	148, 171	24710N-610.....	247	69012.....	209
9151x.....	46, 152	33806-A.....	243, 247	69016.....	209
9154x.....	45, 150	33806-B.....	247	69020.....	209
9205x.....	148	33806B-Y06.....	243, 247	69024.....	209
9255x.....	149	33806B-Y24.....	243, 247	69032.....	209
9315x.....	149, 186	33806B-Y26.....	243, 247	106370.....	221
9355x.....	150	33806B-Y28.....	243, 247	106470.....	221
9365x.....	151, 189	33806B-Y34.....	243, 247	211273A.....	116
9385x.....	150	33806B-Y36.....	247	211280A.....	116
9405x.....	151	33806B-Y38.....	243, 247		
9405x-LL.....	151	38166-01812.....	245		
9406x.....	153	38166-02137.....	245		
9435x.....	153	38166-02412.....	245		
9455x.....	152	38166-02837.....	245		
9456x.....	153	38166-03012.....	245		
9515x.....	152, 153	38166-03200.....	245		
9705x.....	219	38166-03437.....	245		
10004B-102.....	246	38166-03612.....	245		
10004B-104.....	246	38166-04112.....	245		
10004B-304.....	246	38353-01800.....	245		
10004B-305.....	246	38353-02037.....	245		
10004B-405.....	246	38353-02400.....	245		
10004B-604.....	246	38353-02837.....	245		
10004B-A04.....	246	38353-03000.....	245		
10004B-A05.....	246	38353-03200.....	245		
10004B-B03.....	246	38353-03437.....	245		
10004B-B04.....	246	38353-03600.....	245		
10004B-B05.....	246	38353-04112.....	245		
10004B-Y04.....	246	41157x.....	124, 171		
10005B-102.....	246	50008.....	208		
10005B-104.....	246	50008x12.....	208		
10005B-405.....	246	50012.....	208		
10005B-B05.....	246	50016.....	208		
10005B-B06.....	246	50016x20.....	208		
10005B-C02.....	246	50020x16.....	208		
10005B-C04.....	246	50020.....	208		
10005B-Y05.....	246	50024.....	208		
10006B-102.....	246	50032.....	208		
10006B-104.....	246	54508.....	208		
10006B-106.....	246	54508x12.....	208		
10006B-306.....	246	54512.....	208		
10006B-406.....	246	54516.....	208		
10006B-606.....	246	54516x20.....	208		
10006B-B06.....	246	54520x16.....	208		
10006B-Y06.....	246	54520.....	208		
24704N-102.....	247	54524.....	208		
24704N-104.....	247	54532.....	208		
24704N-604.....	247	59008.....	208		
24704N-B04.....	247	59008x12.....	208		
24705N-104.....	247	59012.....	208		
24705N-605.....	247	59016.....	208		
24705N-B05.....	247	59016x20.....	208		
24706N-104.....	247	59020x16.....	208		
24706N-106.....	247	59020.....	208		
24706N-406.....	247	59024.....	208		
24706N-604.....	247	59032.....	208		
24706N-605.....	247	60008.....	209		

Warranty

WEATHERHEAD WARRANTY

WARRANTY:

For one year after date of purchase, Weatherhead warrants its products to be free from defects in materials and workmanship when properly installed and maintained. Products covered include those items contained in this catalog.

If during the warranty period, a product is discovered to be defective, Weatherhead will, at its option, replace the warranted product or grant the purchaser a credit for the product claimed to be defective. Weatherhead will have the sole discretion to determine whether the product was defective.

This warranty is null and void if the product has been used in the wrong application or has been damaged from an accident or willfully destroyed. In addition, this warranty will not apply to Weatherhead assembly equipment, Weatherhead end fittings, and Weatherhead hose if the claimed defective product has been used in an assembly made from other than Weatherhead parts.

NO WARRANTY OF MERCHANTABILITY OR FITNESS FOR A PARTICULAR PURPOSE, NOR ANY OTHER WARRANTY, EXPRESS OR IMPLIED, IS MADE BY WEATHERHEAD. THE FOREGOING STATES DANA CORPORATION'S ENTIRE AND EXCLUSIVE LIABILITY AND BUYER'S EXCLUSIVE REMEDY FOR ANY CLAIM OR DAMAGES IN CONNECTION WITH THE SALE OF THE PRODUCTS HEREUNDER. IN NO EVENT SHALL WEATHERHEAD BE LIABLE FOR ANY SPECIAL, INCIDENTAL, OR CONSEQUENTIAL DAMAGES WHATSOEVER.

SOME STATES DO NOT ALLOW THE EXCLUSION OR LIMITATION OF INCIDENTAL OR CONSEQUENTIAL DAMAGES, SO THE ABOVE LIMITATION MAY NOT APPLY TO YOU.

THIS WARRANTY GIVES YOU SPECIFIC LEGAL RIGHTS AND YOU MAY ALSO HAVE OTHER LEGAL RIGHTS WHICH VARY FROM STATE TO STATE.

CLAIM INFORMATION:

To make a claim under this warranty:

1. Return the defective product along with the purchase receipt and a copy of this certificate to your local distributor or Weatherhead sales representative or to the attention: Engineering Lab, at the following address:

Hose and Fittings
Weatherhead Division
U.S. Route 24, East
Antwerp, OH 45813

Tooling
Boston Weatherhead Division
1380 South Williams Drive
Columbia City, IN 46725

2. In the event of a question or difficulty, contact your local distributor, Weatherhead sales representative or Weatherhead Product Engineering at the above address.

Distributed by:

Eaton
14615 Lone Oak Road
Eden Prairie, MN 55344
USA
tel: 952 937-9800
fax: 952 974-7722
www.hydraulics.eaton.com



© 2003 Eaton Corporation
All Rights Reserved
Printed in USA
Form No. W-HYOV-MC001-E
March 2003