

Pilot Operated Check Valves

4CG-10, 20 Series

4CS-03, 20 Series

4CT-06/10, 20 Series

Typical Section

4CT1-06-D*-20-UB, illustrating external drain and decompression features

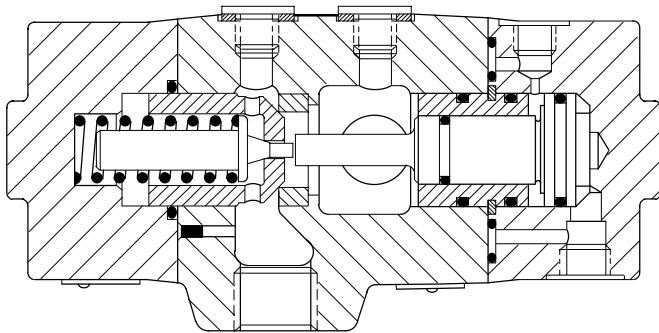

Basic Characteristics

Maximum pressure Up to 210 bar (3000 psi)
 Nominal flow rate Up to 280 L/min (74 USgpm)

Mounting:

4CG-10 models Subplate/manifold
 4CS-03 models 3/4"-16 UNF, SAE
 4CT-06 models G3/4 (3/4" BSPF)
 4CT-10 models G1 1/4 (1 1/4" BSPF)

General Description

These pilot operated check valves operate as standard check (non-return) valves in one direction, but can also be opened by a remote pilot pressure signal to permit reverse flow.

An optional decompression feature (used in conjunction with appropriate pilot pressures) provides for the controlled decompression of large volumes of pressure fluid before the valve opens to allow full flow.

See catalog 2329 for other subplate-mounted pilot operated check valves for pressures up to 350 bar (5000 psi) and flow rates up to 300 L/min (80 USgpm) and with integrally mounted solenoid operated pilot valves.

Functional Symbols

4CG

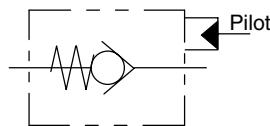

4CG1/2

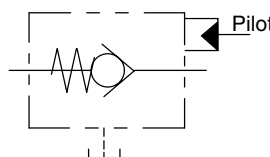

4CS/T

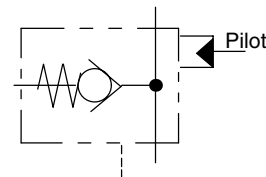

4CT1

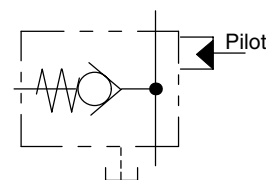

Model Codes

Features in brackets () may be omitted.
All other features must be specified.

For Subplate-Mounted Model

(F3-)4CG (*)-10-(D) * -2* -UG

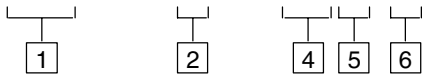

For Thread-Mounted Models

Size 03:

(F3-)4CS-03- (D) * -2*



Sizes 06 and 10:

(F3-)4CT (1)-- (D) * -2* -UB**

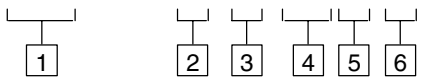

1 Fluid compatibility

Blank = Antiwear hydraulic oil
(class L-HM), invert emulsion
(L-HFB) or water glycol (class
L-HFC)

F3 = As above or phosphate ester
(class L-HFD)

6 Design number, 2* series

Subject to change. Installation
dimensions unaltered for design
numbers 21-29.

2 Pilot piston external drain option

(Not available on 4CS-03 models)

1 = Drain through lower cover

For 4CG*-10 model only:

2 = Drain through interface port

3 Nominal size

For 4CT models only:

06 = 3/4" nominal bore pipe size

10 = 1 1/4" nominal bore pipe size

4 Decompression feature

Omit "D" if not required

5 Cracking (opening) pressure

A = 2 bar (30 psi)

B = 3,4 bar (50 psi) (except 4C*-10)

C = 5 bar (75 psi)

F = 10 bar (150 psi)

Operating Data

Maximum pressures All ports, all models	210 bar (3000 psi)
Nominal flow rates: 4CS-03 4CT-06 4CT-10, 4CG-10	45 L/min (12 USgpm) at Δp 1,7 bar (25 psi) 114 L/min (30 USgpm) at Δp 2,8 bar (40 psi) 284 L/min (75 USgpm) at Δp 3,4 bar (50 psi)
Cracking (opening pressure)	See "Model Code" [5]
Pilot pressures	See "Pilot Pressures" below
Area ratios Pilot piston to check valve: 4CS-03, 4CT-06 4CT-10, 4CG-10 Pilot piston to decompression poppet: 4CS-03 4CT-06 4CT-10, 4CG-10	3,5:1 2,6:1 33,8:1 52,6:1 77,0:1
Hydraulic fluids	See "Model Code" [1] and "Hydraulic Fluids"
Temperatures Ambient: Min. Max. Fluid temperatures	-20°C (-4°F) +70°C (158°F) See "Fluid Temperatures"
For 4CG model only: Subplate Mounting bolts	E-RXGM-10(X), see page 6 See "Installation Data"
Mass (weight): 4CS-03 4CT-06 4CT-10 4CG-10	2,8 kg (6.2 lb) 5,7 kg (12.5 lb) 12,1 kg (26.7 lb) 11,9 kg (26.2 lb)

Hydraulic Fluids

All valves can be used with the fluids specified in "Model Code" [1]. Prefix "F3-" must be specified to obtain seals suitable for operation with phosphate esters (not alkyl based).

The extreme operating viscosity range is from 13 to 860 cSt (70 to 4000 SUS), but the recommended running range is 13 to 54 cSt (70 to 245 SUS).

For further information about fluids see leaflet 920.

Contamination Control Requirements

Recommendations on contamination control methods and the selection of products to control fluid condition are included in Vickers publication 9132 or 561, "Vickers Guide to Systemic Contamination Control". The book also includes information on the Vickers concept of "ProActive Maintenance". The following recommendations are based on ISO cleanliness levels at 2 µm, 5 µm and 15 µm. For products in this catalog the recommended levels are:

Up to 210 bar (3000 psi) **19/17/14**

Fluid Temperature

	Petroleum oil	Water-containing
Min.	-20°C (-4°F)	+10°C (50°F)
Max.*	+80°C (+176°F)	+54°C (130°F)

* To obtain optimum service life from both fluid and hydraulic system 65°C (150°F) normally is the maximum temperature except for water-containing fluids.

For synthetic fluids consult manufacturer or Vickers representative where limits are outside of those for petroleum oil. Whatever the actual temperature range, ensure that viscosities stay within the limits specified under "Hydraulic Fluids".

Pilot Pressures

The pilot pressure required to open the check valve or decompression poppet is stated as a ratio of the pressure on the check to the pilot pressure. To determine the required pilot pressure the following formulae should be used.

For internally drained pilot piston models, no symbol at model code [2]:

$$\text{Pilot pressure} = \frac{P_{\text{out}} - P_{\text{in}}}{\text{Area ratio}} + P_{\text{in}} + C$$

For externally drained pilot piston models, "1" (or "2" for 4CG) at model code [2]:

$$\text{Pilot pressure} = \frac{P_{\text{out}}}{\text{Area ratio}} + C$$

Where:

P_{in} = Pressure (bar) at free flow inlet
 P_{out} = Pressure (bar) at free flow outlet
 C = Varies according to model/
 cracking pressure, see table.

Model "C" factor for cracking pressure, model code [5]

Model	A	B	C	F
4CS-03	0,6	1,0	1,5	4,0
4CT-06	0,6	1,0	1,5	3,0
4CT-10	0,8	2,0	-	4,0
4CG-10	0,8	2,0	-	4,0

Installation Dimensions in mm (inches)

4CS-03 and 4CT(1)-06/10 Pipe-Mounted Models

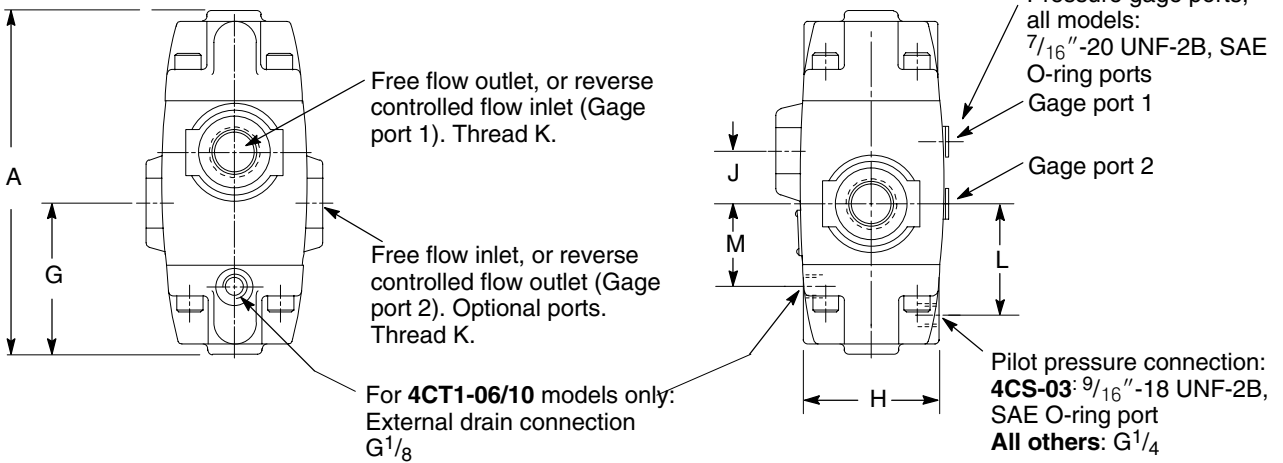
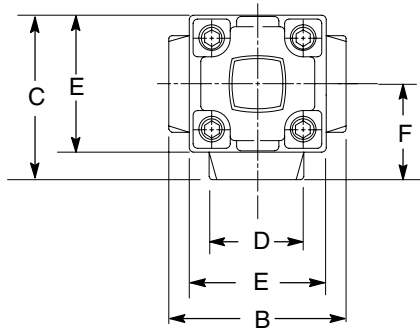
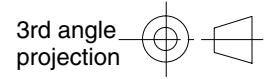

Model	A	B	C	D	E	F	G	H	J	K	L	M
4CS-03	122 (4.8)	70 (2.76)	70 (2.76)	35 (1.38)	60 (2.36)	40 (1.57)	53 (2.09)	57 (2.24)	23,1 (0.91)	$3/4''$ -16 UNF-2B	45,2 (1.78)	-
4CT(1)-06	178 (7.0)	93 (3.66)	89 (3.5)	50,8 (2.0)	75 (2.95)	50,8 (2.0)	78 (3.07)	70 (2.76)	26,9 (1.06)	$G^{3/4}$ (BSPF)	57,2 (2.25)	42,7 (1.68)
4CT-10	194 (7.6)	118 (4.64)	118 (4.64)	86,4 (3.4)	99 (3.9)	68,3 (2.69)	84 (3.31)	95 (3.74)	28,9 (1.14)	$G^{1 1/4}$ (BSPF)	70,6 (2.78)	-
4CT1-10	204 (8.03)	118 (4.64)	118 (4.64)	86,4 (3.4)	99 (3.9)	68,3 (2.69)	94 (3.7)	95 (3.74)	28,9 (1.14)	$G^{1 1/4}$ (BSPF)	82 (3.23)	54,6 (2.15)

4CG(*)-10, Subplate-Mounted Models

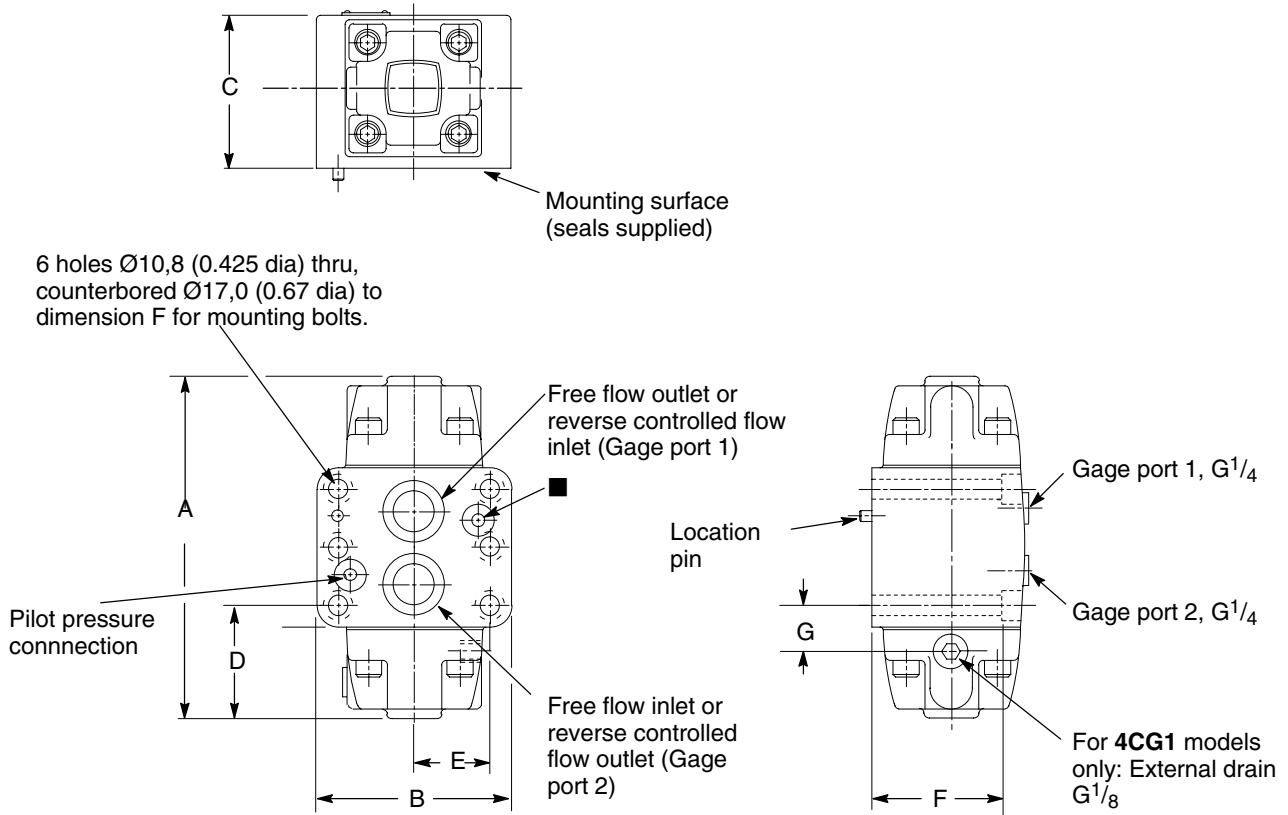

■ When using 4CG-10 or 4CG1-10 models, plug this connection at the subplate or at the mounting face (e.g. do not drill matching hole in subplate/ manifold block).

Model	A	B	C	D	E	F	G
4CG-10	194 (7.64)	118 (4.65)	100 (3.93)	55 (2.17)	48,4 (1.91)	95,3 (3.75)	–
4CG*-10	204 (8.03)	118 (4.65)	100 (3.93)	65 (2.56)	48,4 (1.91)	95,3 (3.75)	26 (1.0)

E-RXGM-10(X) Subplate
For 4CG (*)-10 Models

When a subplate is not used, a machined pad (as indicated by shaded area) must be provided for mounting. The pad must be flat within 0,013 mm (0.0005 in) and smooth within 1,6 μm (63 microinch). Mounting bolts provided by the customer should be Class 12,9 (ISO 898) or better.

For external drain connection for **4CG2** models only:
 Ø4,8 (0.19 dia) at mounting face;
 G¹/₄ on rear face
When used for 4CG or 4CG1 models this connection must be plugged.

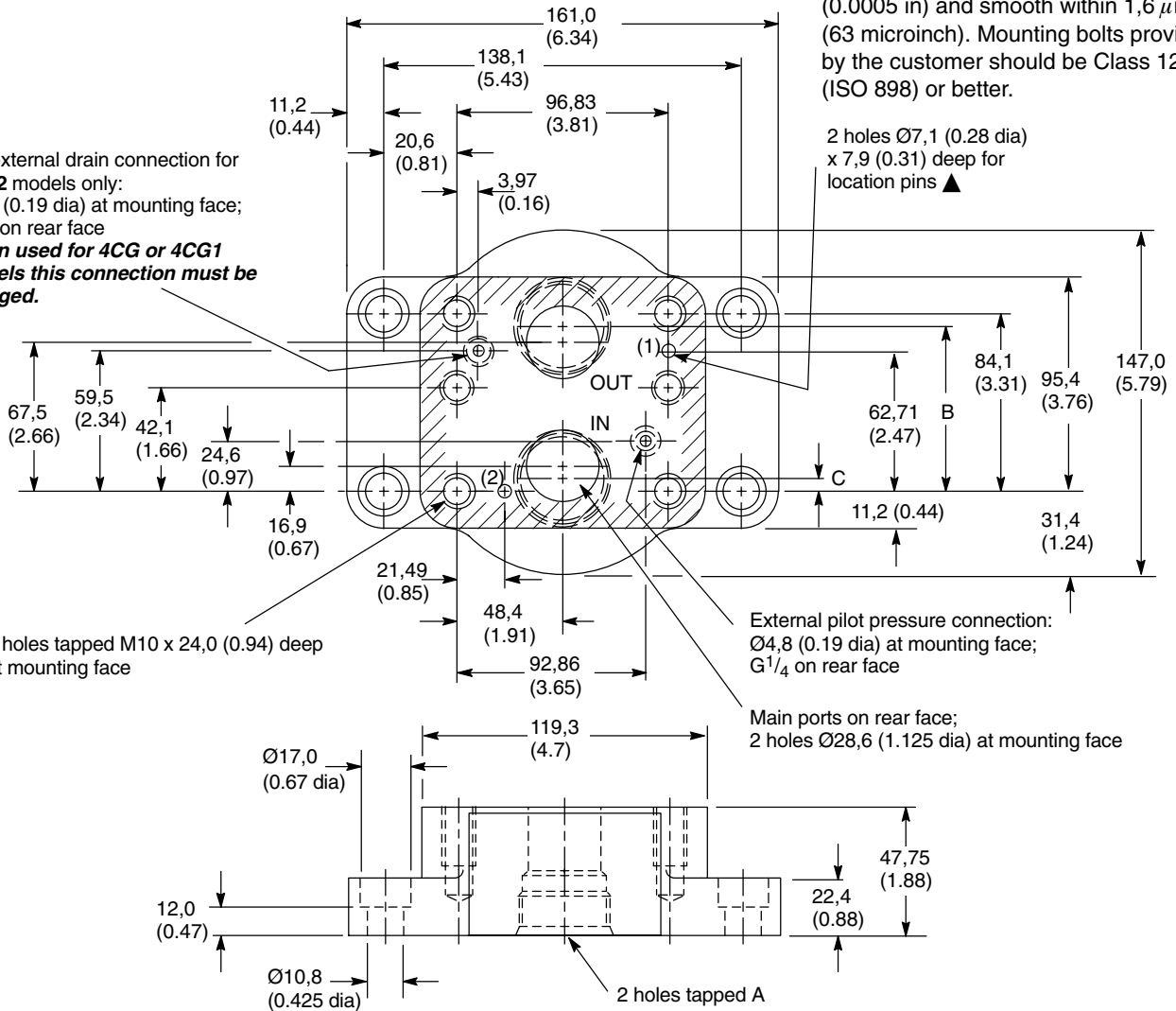

Model	A	B	C
E-RXGM-10-20R	G ¹ / ₄ (1 ¹ / ₄ " BSPF)	76,2 (3.0)	7,9 (0.31)
E-RXGM-10X-20R	G ¹ / ₂ (1 ¹ / ₂ " BSPF)	78,1 (3.1)	6,0 (0.24)

▲ Pin at location (1) for pilot operated check valves; at location (2) for pressure reducing valves.

Installation Data

Mounting Attitude
 No restrictions

Mounting Bolts

Bolt kit BKRX-10-662M
 If not using Vickers recommended bolt kit, bolts used should be to ISO 898 class 12,9 or better.
 Recommended bolt torque 49-59 Nm (36-44 lbf ft)

Ordering Procedure

Specify full model code.