



Sandwich Valves

CETOP03 (NG6) Sandwich valve bodies and assemblies for applications up to 210 bar (3000 psi)



Section Contents

Sandwich Valve
Systems

Model	Page
Section Introduction, application guidelines and ordering information	L-3
Spare parts & Accessories for Sandwich Valve assemblies	L-5
Valve Locator	
Pressure control valves	L-6
Check and Pilot control valves	L-9
Flow control valves	L-10
Solenoid valves	L-13
Load control valves	L-18
Spacer / Blanking / Linking Plates	L-19
Model Code Detail	
Model Code descriptions for assemblies with two cartridges	L-20
Housing Dimensions	
ISO 4401-03 CETOP3 Housings - Dimensions	L-25

Typical Sandwich Valve System

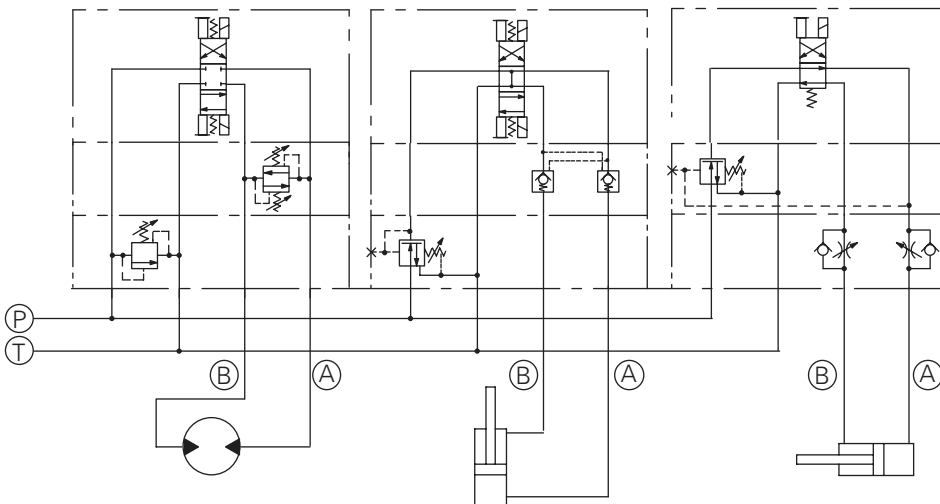

WARNING
Aluminum housing is only to be used for pressures up to 210 bar (3000 psi).



WARNING
Application of these products beyond published performance specifications may cause valve malfunction which may result in personal injury and/or damage to the machine.

Sandwich Valves

Build a Compact, Cost effective, Reliable Hydraulic System with Vickers aluminum Sandwich Valves and SICV valves

Reduces System Space Requirements

Sandwich valves make compact hydraulic systems in which specific function valves are "sandwich" mounted between a directional valve and a standard mounting surface.

Reduce Cost

Sandwich valves eliminate inter valve piping and leak-prone tube and pipe connections. Installed cost is less than when using conventional valves.

Versatile and Easy to Install

Sandwich valves have all the internal passages necessary to serve the directional valve topping them. Mounting surfaces and port patterns are to international standards: any valve conforming to ISO 4401 size 03; ANSI/B93.7M size D03; NFPA-D03; CETOP 3; and DIN 24340, NG6 mounting interface can be used with these Sandwich valves.

Linking and blanking plates are available to facilitate a variety of circuit designs and flexibility in applying these valves.

Rugged and Reliable

Cartridges are produced from hardened steel and mounted in aluminum housings. Excellent reliability is ensured. Cartridges are accessible without removing valves from an assembled stack. The housings are assembled in a kit

containing a locating pin for error free installation, all necessary plugs and standard Viton seals.

Sandwich Systems... Easy to Understand, Easy to Design

Sandwich circuitry is best shown using slightly different symbols than those for traditional valve configurations. Each Sandwich symbol has the same basic form and size as shown in figure 1.

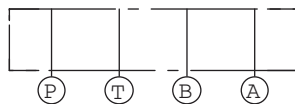

For ease of understanding, remember the directions of flow for each line, and that all four flow paths pass through each valve (see figure 2).

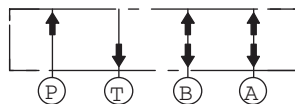

For clarity, directional valves are drawn vertically in Sandwich circuit diagrams (see figure 3).

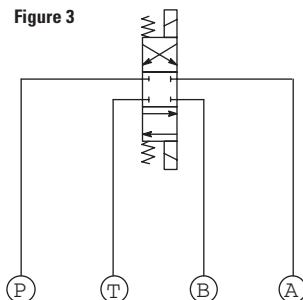

Each station (valve stack) is a combination of functions. When designing and assembling Sandwich valves, care must be taken to ensure that they interact as required by stacking the functions in the correct sequence (figure 4 is an example).

Figure 4

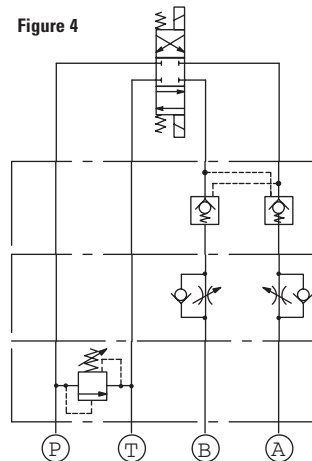

Relief valves should normally be positioned next to the mounting surface (i.e. at the bottom of the stack). When both a flow control and a pilot operated check valve are required, it is recommended that the flow control valve be between the check valve and the actuator to prevent check valve chatter.

A combination of directional valve, sandwich valve(s) and subplate/manifold block completes the assembly.

Sandwich Valve Assemblies

Aluminum sandwich valve assemblies consist of a housing kit, and one or more cartridges. They can be purchased complete by specifying a sandwich

model code or built by mixing an appropriate housing kit with cartridges to attain a desired function.

A housing kit contains a housing, locating pin, all necessary plugs and standard Viton seals.

Sandwich Valve Locators

Sandwich valve locators group products by function and provides an easy way to identify a specific sandwich valve in the catalog.

It presents a sandwich valve functional symbol, function description and basic model code. Since every sandwich is put together by inserting cartridges into a housing kit, the locator provides concise information for easy selection of the components to build a specific function.

The following information is shown in the locator for every function: Housing kit model, part number, catalog page with the detailed information for the housing kit, model code and the catalog number for the cartridges & cartridge cavity.

Housing Kits Data Page

Housing kits data pages L-25 thru L-44 provide the dimensional data, typical cartridges and functional information.

Sandwich Model code information

Easy to understand, easy to design

Sandwich Valves Ordering Information

To order sandwich valve components, use the information in the sandwich valves locator pages L-6 thru L-19.

To order a sandwich valve complete for models with one cartridge:

- Select the model code from the sandwich valve locator. Note that the housing kit model code substitutes for the standard inline body code in the same model field.
- Go to the referenced cartridge valve literature to complete the balance of the sandwich model code.

To order a sandwich valve complete for models with two cartridges:

- Select the model code from the sandwich valves locator.
- Go to the referenced page for the model code description.

Sandwich Valve Model Codes

In order to speed the release of new products to customers, the sandwich valve product line has been configured with a fixed length model code. A fixed length model code simplifies the ordering process for our customers and facilitates the automated production release of new

valves and settings. In general, we have followed the standard model code for the base valve with the following three exceptions:

1. Seals: When specifying Buna-N seals, an N should be used in the model code for sandwich valves. (In the standard valve model code Buna-N seals are specified by leaving this column blank.)
2. Pressure settings: To avoid confusion on pressure settings, the setting should always be specified and not left blank. In addition, the confusing decimal system has been eliminated for sandwich valves. In the sandwich valve model code, simply specify the entire pressure setting in PSI using four digits for relief valves and 3 digits for check valves. Include leading zeros if necessary. For example:

Relief and Counterbalance Valves

500 psi – 0500
50 psi – 0050
1525 psi – 1525

Check Valves

210 psi – 210
20 psi - 020
3 psi - 003

3. Flow settings: To avoid confusion, the setting should always be specified and not left blank. In the sandwich valve model codes, all flow settings are specified in tenths of a GPM without decimal points. (include

trailing zeroes and leading zeros if where required.) For example:

1 gpm – 010
1.2 gpm – 012
15 gpm - 150

Two examples are shown below:

Base valve model code

RV5-10(V)-*-**-**/****

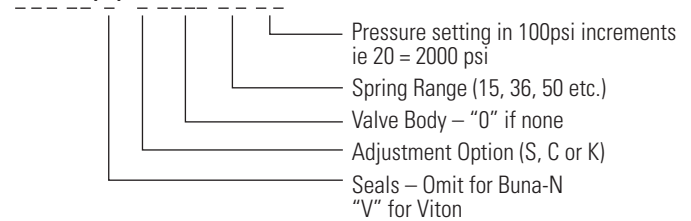

Sandwich valve model code

RV5-10*-*-A321P-/****

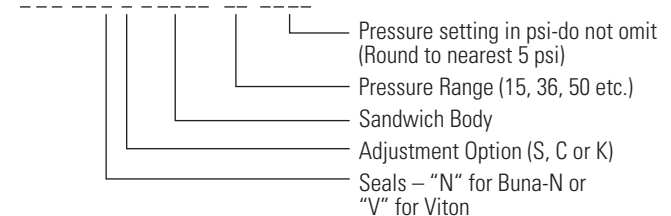

Base valve model code

FAR1-10(V)-*-**-*.***

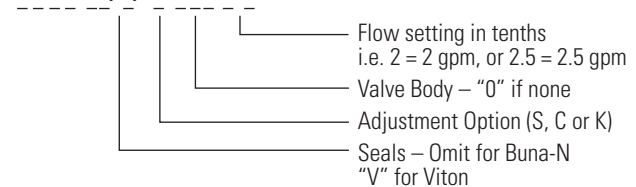

Sandwich valve model code (relieving from P to T)

FAR1-10*-*-A324A-***

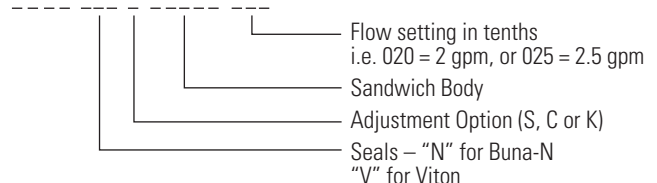

Spare Parts

For Sandwich Valve Assemblies

Accessory Plates & Stud Rods

Accessory Plates

Linking and blanking plates are available to facilitate a variety of circuit designs and flexibility in applying these valves. All accessory plates come with Viton O-Rings.

Stud Rods

To simplify the installation of the sandwich valves, stud rod & nuts kits can be ordered and cut to length in the field. Once the rods are installed, they act as a guide when assembling the sandwich valves stack. After assembling the directional control valve on top of the stack, special nuts are used to retain the stack. Eaton offers 178 mm (7 in) or 305 mm (12 in) bolt kits (one bolt kit for these Sandwich valves comprises 4 bolts). To determine your needs, use the following guide for bolt length calculation.

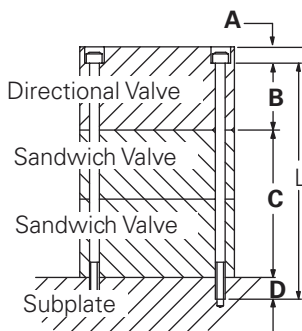

- A** Amount of thread required for the stud nut 10,2 (0.40)
- B** Bolt clamp length in directional valve, blanking plate etc.
- C** Height of intermediate valve stack, comprising Vickers Sandwich valve(s) plus tapping plates etc.
- D** Depth of thread engagement in sub-plate/ manifold block. Minimum amount of thread required 10,2 mm (0.40 in.)
- L** Required bolt length; select from the table

Note

1. Bolts should be torqued to 4.5-6.0 Nm (40-53 in. lbs) with threads lubricated.
2. If not using Eaton bolt kits, bolts must be to Grade 12.9 (ISO 898) or better.

STUD ROD & NUT KIT*

Metric: M5-0.8thd		Inch: 10-24	
Length (mm)	Kit number	Length (in)	Kit number
178	02-184934	7	02-184932
305	02-184935	12	02-184933

*Kit contains four stud rods and four stud nuts

Spare Parts

Stud rod and nut kits are listed above. Individual nuts are also available:

NUTS		SEAL KITS	
Length (Thd)	Kit number	Seal material	Seal Kit number
10-24	02-184940	Buna N	02-184951
M5-0.8	02-184941	Viton	02-185282

Filtration Requirements

For products in this catalog the recommendation fluid cleanliness levels is:
Up to 210 bar (3000 psi)
18/16/13

Temperature Limits

Ambient range:
-40° C to +120° C
(-40° F to +248° F)

Ordering Procedure

Specify requirements by housing kit, or valve model code, and by seal kit number.



Pressure Control Functions

Sandwich Valves Locator
ISO 4401-03/CETOP
03 series

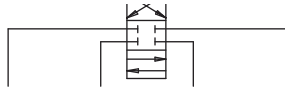

Function	Functional Symbol	Model Code		
Relief valve P-T		RV1 10 * * A321P **/**** 00	Hsg kit: model Part No.	A321P 02 185342
Relief valve A-T		RV1 10 * * A321A **/**** 00	Hsg kit: model Part No.	A321A 02-185340
Relief valve B-T		RV1 10 * * A321B **/**** 00	Hsg kit: model Part No.	A321B 02-185341
Proportional relief valve P-T		ERV1 10 * *** A321P *** * 00	Hsg kit: model Part No.	A321P 02-185342
Proportional relief valve A-T		ERV1 10 * *** A321A *** * 00	Hsg kit: model Part No.	A321A 02-185340
Proportional relief valve B-T		ERV1 10 * *** A321B *** * 00	Hsg kit: model Part No.	A321B 02-185341
Relief valve P-T		RV5 10 * * A321P **/**** 00	Hsg kit: model Part No.	A321P 02-185342
Relief valve A-T		RV5 10 * * A321A **/**** 00	Hsg kit: model Part No.	A321A 02-185340
Relief valve B-T		RV5 10 * * A321B **/**** 00	Hsg kit: model Part No.	A321B 02-185341



CAUTION
Sandwich valve flow ratings are limited by the ratings of individual cartridges. Consult cartridge valve literature.

Pressure Control Functions

Function	Functional Symbol	Model Code	Hsg kit: model Part No.	Cartridge Cartridge Data Sheet Cavity
Solenoid Controlled Relief valve P-T Normally Open		SRV 10 * 0 S A322P 35/ *** ** Refer to page L-20 for model code breakdown	A322P 02-185344	SV5-8-0/RV1-10 Section A/E C-8-2/C-10-2
Solenoid Controlled Relief valve P-T Normally Closed		SRV 10 * C S A322P 35/ *** ** Refer to page L-20 for model code breakdown	A322P 02-185344	SV5-8-C/RV1-10 Section A/E C-8-2/C-10-2
Dual Relief valve A-T, B-T		RV1 8 * * A311W A**/****B**/**** 00 Refer to page L-21 for model code breakdown	A311W 02-185364	RV1-8 qty 2 Section E C-8-2 qty 2
Dual Relief valve A-T, B-T		RV1 10 * * A312W A**/****B**/**** 00 Refer to page L-20 for model code breakdown	A312W 02-185365	RV1-10 qty 2 Section E C-10-2 qty 2
Dual Relief valve A-T, B-T		RV5 10 * * A312W A**/****B**/**** 00 Refer to page L-20 for model code breakdown	A312W 02-185365	RV5-10 qty 2 Section E C-10-2 qty 2
Cross port relief valve A-B		RV3A 10 * * A321W A**/****B**/**** 00 Refer to page L-20 for model code breakdown	A321W 02-185343	RV3A-10 qty 2 Section E C-10-2 qty 2
Cross port relief valve A-B		RV5A 10 * * A321W A**/****B**/**** 00 Refer to page L-20 for model code breakdown	A321W 02-185343	RV5A-10 qty 2 Section E C-10-2 qty 2
Sequence valve In to P		PSV7 10 * * A316P **/**** 00 Refer to page L-21 for model code breakdown	A316P 02-185374	PSV7-10 Section E C-10-3
Sequence valve In to A Reverse FF Check		PSV7 10 * * A316A **/**** 00 Refer to page L-21 for model code breakdown	A316A 02-185372	PSV7-10/CV3-10 Section E/G C-10-3/C-10-2



CAUTION
Sandwich valve flow ratings are limited by the ratings of individual cartridges. Consult cartridge valve literature.

Pressure Control Functions

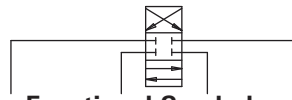

Function	Functional Symbol	Model Code	Hsg kit: model Part No.	Cartridge Cartridge Data Sheet Cavity
Sequence Valve Out of A Reverse FF Check		PSV7 10 * * A319A **/**** 00 Refer to page L-21 for model code breakdown	A319A 02-185377	PSV7-10/CV3-10 Section E/G C-10-3/C-10-2
Sequence Valve In to B Reverse FF Check		PSV7 10 * * A316B **/**** 00 Refer to page L-21 for model code breakdown	A316B 02-185373	PSV7-10/CV3-10 Section E/G
Sequence Valve Out of B Reverse FF Check		PSV7 10 * * A319B **/**** 00 Refer to page L-21 for model code breakdown	A319B 02-185378	PSV7-10/CV3-10 Section E/G
Reducing Valve on (P) Drained to T		PRV2 10 * * A326P **/**** 00 Refer to page L-21 for model code breakdown	A326P 02-185353	PRV2-10 Section E
Reducing on A Drained to T Reverse FF Check		PRV2 10 * * A310A **/**** 00 Refer to page L-21 for model code breakdown	A310A 02-185362	PRV2-10/CV3-10 Section E/G
Reducing on B Drained to T Reverse FF Check		PRV2 10 * * A310B **/**** 00 Refer to page L-21 for model code breakdown	A3210B 02-185363	PRV2-10/CV3-10 Section E/G
Pressure Compensator Restrictive on P w/Shuttle sense from A & B		PCR 10 * A309P *** 00 Refer to page L-22 for model code breakdown	A309P 02-185381	DPS2-10-F-F-0/DSV2-8 Section E/D C-10-3S/C-8-3
Pressure Compensator Bypass to T w/Shuttle sense from A & B		PCB 10 * A319P *** 00 Refer to page L-22 for model code breakdown	A319P 02-185382	DPS2-10-P-F-0/DSV2-8 Section E/D



CAUTION
Sandwich valve flow ratings are limited by the ratings of individual cartridges. Consult cartridge valve literature.

Check & Pilot Check Functions

Function	Functional Symbol	Model Code	Hsg kit: model Part No.	Cartridge Cartridge Data Sheet Cavity
Pilot Operated Check Valve On A Pilot from B		POC1 10 * * A323A *** 00	A323A 02-185345	POC1-10 Section G C-10-3S
Pilot Operated Check Valve On B Pilot from A		POC1 10 * * A323B *** 00	A323B 02-185346	POC1-10 Section G
Pilot Operated Check Valve On A & B Cross Piloted		POC1 10 * * A323W *** 00	A323W 02-185347	POC1-10qty 2 Section G
Check Valve On P		CV3 8 * P A307P *** 00	A307P 02-185356	CV3-8 Section G
Check Valve On P		CV3 10 * P A324P *** 00	A324P 02-185350	CV3-10 Section G
Check Valve On T		CV3 8 * P A307T *** 00	A307T 02-185357	CV3-8 Section G
Check Valve On T		CV3 10 * P A308T *** 00	A308T 02-185360	CV3-10 Section G
Check Valve On A Free Flow Out		CV3 8 * P A307A *** 00	A307A 02-185354	CV3-8 Section G
Check Valve On A Free Flow Out		CV3 10 * P A314A *** 00	A314A 02-185367	CV3-10 Section G



CAUTION
Sandwich valve flow ratings are limited by the ratings of individual cartridges. Consult cartridge valve literature.

Check and Flow Control Functions

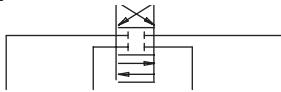

Function	Functional Symbol	Model Code	Hsg kit: model Part No.	Cartridge Cartridge Data Sheet Cavity
Check Valve On B Free Flow Out		CV3 8 * P A307B *** 00	A307B 02-185355	CV3-8 Section G C-8-2
Check Valve On B Free Flow Out		CV3 10 * P A314B *** 00	A314B 02-185368	CV3-10 Section G
Check Valve On T to A & B		CV3 8 * P A320T *** 00	A320T 02-185379	CV3-8 qty 2 Section G
Check Valve On T to A & B		CV3 10 * P A317T *** 00	A317T 02-185375	CV3-10 qty 2 Section G
Anti-Cavitation Check P-T		CV16 10 * P A321P *** 00	A321P 02-185342	CV16-10-P-0-5 Section G
Shuttle Valve A & B Output External		DSV2 8 * B A309W 00	A309W 02-185361	DSV2-8-B-0 Section F
Flow Control Meter in P		NV1 10 * * A324P 00	A324P 02-185350	NV1-10 Section F
Flow Control & Check Meter in A		FCV7 10 * * A324A FF 00	A324A 02-185348	FCV7-10 Section F
Flow Control & Check Meter Out A		FCV7 10 * * A314A FF 00	A314A 02-185367	FCV7-10 Section F
Flow Control & Check Meter in B		FCV 7 10 * * A324B FF 00	A324B 02-185349	FCV7-10 Section F



CAUTION
Sandwich valve flow ratings are limited by the ratings of individual cartridges. Consult cartridge valve literature.

Flow Control Functions

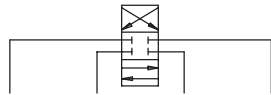

Function	Functional Symbol	Model Code	Hsg kit: model Part No.	Cartridge Cartridge Data Sheet Cavity
Flow Control & Check Meter Out B		FCV7 10 * * A314B FF 00	A314B 02-185368	FCV7-10 Section F C-10-2
Flow Control & Check Meter In A & B		FCV7 10 * * A324W FF 00 Refer to page L-22 for model code breakdown	A324W 02-185351	FCV7-10 qty 2 Section F
Flow Control & Check Meter Out A & B		FCV7 10 * * A314W FF 00 Refer to page L-22 for model code breakdown	A314W 02-185369	FCV7-10 qty 2 Section F
Flow Regulator Pressure Compensated Meter In P		FAR1 10 * * A324P *** 00	A324P 02-185350	FAR1-10 Section F
Flow Regulator Pressure Compensated and Check Meter In A		FAR1 10 * * A314A *** 00	A314A 02-185367	FAR1-10 Section F
Flow Regulator Pressure Compensated and Check Meter Out A		FAR1 10 * * A324A *** 00	A324A 02-185348	FAR1-10 Section F
Flow Regulator Pressure Compensated and Check Meter In B		FAR1 10 * * A314B *** 00	A314B 02-185368	FAR1-10 Section F
Flow Regulator Pressure Compensated and Check Meter Out B		FAR1 10 * * A324B *** 00	A324B 02-185349	FAR1-10 Section F
Flow Regulator Pressure Compensated and Check Meter In, A & B		FAR1 10 * * A314W A***B*** 00	A314W 02-185369	FAR1-10 qty 2 Section F



CAUTION
Sandwich valve flow ratings are limited by the ratings of individual cartridges. Consult cartridge valve literature.

Flow Control & Solenoid Control Functions

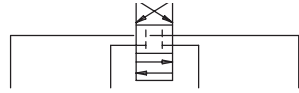

Function	Functional Symbol	Model Code	Hsg kit: model Part No.	Cartridge Cartridge Data Sheet Cavity
Flow Regulator Pressure Compensated and Check Meter Out, A & B		FAR1 10 * * A324W A***B*** 00	A324W 02-185351	FAR1-10 qty 2 Section F C-10-2 qty 2
Proportional Flow Control Pressure Compensated On P		EPV 10 * * A313P *** * * 00 Refer to page L-23 for model code breakdown	A313P 02-185366	EPV-10, DPS2-10 I & B
Solenoid 2 Way Poppet Type (P-T), N/C		SV1 10 * C A325P *** * 00	A325P 02-185352	SV1-10-C Section A
Solenoid 2 Way Poppet Type (P-T), N/O		SV5 10 * O A325P *** * 00	A325P 02-185352	SV5-10-O Section A
Solenoid 2 Way Poppet Type (P-T), N/C		SV3 10 * C A325P *** * 00	A325P 02-185352	SV3-10-C Section A
Solenoid 2 Way Poppet Type (P-T), N/O		SV3 10 * O A325P *** * 00	A325P 02-185352	SV3-10-O Section A
Solenoid 2 Way Spool Type (P-T), N/C		SV4 10 * C A325P *** * 00	A325P 02-185352	SV4-10-C Section A
Solenoid 2 Way Spool Type (P-T), N/O		SV4 10 * O A325P *** * 00	A325P 02-185352	SV4-10-O Section A
Solenoid 2 Way Poppet Type Blocked on A Normally Closed		SV3 10 * C A324A *** * 00	A324A 02-185348	SV3-10-C Section A



CAUTION
Sandwich valve flow ratings are limited by the ratings of individual cartridges. Consult cartridge valve literature.

Solenoid Control Functions

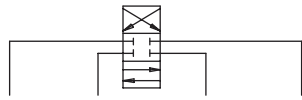

Function	Functional Symbol	Model Code	Hsg kit: model Part No.	Cartridge Cartridge Data Sheet Cavity
Poppet Type Blocked on A Normally Open		SV3 10 * O A324A **** 00	A324A 02-185348	SV3-10-0 Section A C-10-2
Spool Type Blocked on A Normally Closed		SV4 10 * C A324A **** 00	A324A 02-185348	SV4-10-C Section A
Spool Type Blocked on A Normally Open		SV4 10 * O A324A **** 00	A324A 02-185348	SV4-10-0 Section A
Poppet Type Blocked on B Normally Closed		SV3 10 * C A324B **** 00	A324B 02-185349	SVC3-10-C Section A
Poppet Type Blocked on B Normally Open		SV3 10 * O A324B **** 00	A324B 02-185349	SV3-10-C Section A
Spool Type Blocked on B Normally Closed		SV4 10 * C A324B **** 00	A324B 02-185349	SV4-10-C Section A
Spool Type Blocked on B Normally Open		SV4 10 * O A324B **** 00	A324B 02-185349	SV4-10-0 Section A
Poppet Type Blocked on A & B Normally Closed		SV3 10 * C A324W **** 00	A324W 02-185351	SV3-10-C qty 2 Section A
Poppet Type Blocked on A & B Normally Open		SV3 10 * O A324W **** 00	A324W 02-185351	SV3-10-0 qty 2 Section A



CAUTION

Sandwich valve flow ratings are limited by the ratings of individual cartridges. Consult cartridge valve literature.

Solenoid Control Functions

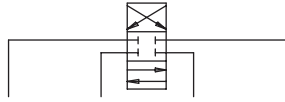

Function	Functional Symbol	Model Code	Hsg kit: model Part No.	Cartridge Cartridge Data Sheet Cavity
Spool Type Blocked on A & B Normally Closed		SV4 10 * C A324W *** 00	A324W 02-185351	SV4-10-C qty 2 Section A C-10-2 qty 2
Spool Type Blocked on A & B Normally Open		SV4 10 * O A324W *** 00	A324W 02-185351	SV4-10-O qty 2 Section A
Poppet Type Load Holding on A Normally Closed		SV3 10 * C A314A *** 00	A314A 02-185367	SV3-10-C Section A
Poppet Type Load Holding on A Normally Open		SV3 10 * O A314A *** 00	A314A 02-185367	SV3-10-O Section A
Poppet Type Load Holding on B Normally Closed		SV3 10 * C A314B *** 00	A314B 02-185368	SV3-10-C Section A
Poppet Type Load Holding on B Normally Open		SV3 10 * O A314B *** 00	A314B 02-185368	SV3-10-O Section A
Poppet Type Load Holding on A & B Normally Closed		SV3 10 * C A314W *** 00	A314W 02-185369	SV3-10-C qty 2 Section A C-10-2 qty 2
Poppet Type Load Holding on A & B Normally Open		SV3 10 * O A314W *** 00	A314W 02-185369	SV3-10-O qty 2 Section A



CAUTION
Sandwich valve flow ratings are limited by the ratings of individual cartridges. Consult cartridge valve literature.

Solenoid Control Functions

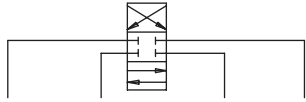

Function	Functional Symbol	Model Code	Hsg kit: model Part No.	Cartridge Cartridge Data Sheet Cavity
Poppet Type Bi-Directional Load Holding on A Normally Closed		SBV11 10 * C A314A *** 00	A314A 02-185367	SBV11-10-C Section A C-10-2
Poppet Type Bi-Directional Load Holding on A Normally Open		SBV11 10 * O A314A *** 00	A314A 02-185367	SBV11-10-0 Section A
Poppet Type Bi-Directional Load Holding on B Normally Closed		SBV11 10 * C A314B *** 00	A314B 02-185368	SBV11-10-C Section A
Poppet Type Bi-Directional Load Holding on B Normally Open		SBV11 10 * O A314B *** 00	A314B 02-185368	SBV11-10-0 Section A
Poppet Type Bi-Directional Load Holding on A & B Normally Closed		SBV11 10 * C A314W *** 00	A314W 02-185369	SBV11-10-C qty 2 Section A
Poppet Type Bi-Directional Load Holding on A & B Normally Open		SBV11 10 * O A314W *** 00	A314W 02-185369	SBV11-10-0 qty 2 Section A
Poppet Type Unload A - T Normally Closed		SV1 10 * C A315A *** 00	A315A 02-185370	SV1-10-C Section A C-10-2
Poppet Type Unload A - T Normally Open		SV5 10 * O A315A *** 00	A315A 02-185370	SV5-10-C Section A



CAUTION

Sandwich valve flow ratings are limited by the ratings of individual cartridges. Consult cartridge valve literature.

Solenoid Control Functions

Function	Functional Symbol	Model Code	Hsg kit: model Part No.	Cartridge Cartridge Data Sheet Cavity
Poppet Type Unload A - T Normally Closed		SV3 10 * C A315A *** * 00	A315A 02-185370	SV3-10-C Section A C-10-2
Poppet Type Unload A - T Normally Open		SV3 10 * O A315A *** * 00	A315A 02-185370	SV3-10-O Section A
Spool Type Unload A - T Normally Closed		SV4 10 * C A315A *** * 00	A315A 02-185370	SV4-10-C Section A
Spool Type Unload A - T Normally Open		SV4 10 * O A315A *** * 00	A315A 02-185370	SV4-10-O Section A
Poppet Type Unload B - T Normally Closed		SV1 10 * C A315B *** * 00	A315B 02-185371	SV1-10-C Section A
Poppet Type Unload B - T Normally Open		SV5 10 * O A315B *** * 00	A315B 02-185371	SV5-10-O Section A
Poppet Type Unload B - T Normally Closed		SV3 10 * C A315B *** * 00	A315B 02-185371	SV3-10-C Section A
Poppet Type Unload B - T Normally Open		SV3 10 * O A315B *** * 00	A315B 02-185371	SV3-10-O Section A
Poppet Type Unload B - T Normally Closed		SV4 10 * C A315B *** * 00	A315B 02-185371	SV4-10-C Section A



CAUTION
Sandwich valve flow ratings are limited by the ratings of individual cartridges. Consult cartridge valve literature.

Solenoid Control Functions

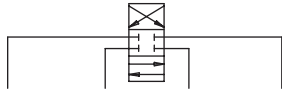

Function	Functional Symbol	Model Code	Hsg kit: model Part No.	Cartridge Cartridge Data Sheet Cavity
2 Way Spool Type Unload B - T Normally Open		SV4 10 * 0 A315B **** 00	A315B 02-185371	SV4-10-0 Section A C-10-2
2 Way Poppet Type Unload A & B - T Normally Closed		SV1 10 * C A317T **** 00	A317T 02-185375	SV1-10-C qty 2 Section A
2 Way Poppet Type Unload A & B - T Normally Open		SV5 10 * 0 A317T **** 00	A317T 02-185375	SV5-10-0 qty 2 Section A
2 Way Poppet Type Unload A & B - T Normally Closed		SV3 10 * C A317T **** 00	A317T 02-185375	SV3-10-C qty 2 Section A
2 Way Poppet Type Unload A & B - T Normally Open		SV3 10 * 0 A317T **** 00	A317T 02-185375	SV3-10-0 qty 2 Section A
2 Way Spool Type Unload A & B - T Normally Closed		SV4 10 * C A317T **** 00	A317T 02-185375	SV4-10-C qty 2 Section A
2 Way Spool Type Unload A & B - T Normally Open		SV4 10 * 0 A317T **** 00	A317T 02-185375	SV4-10-0 qty 2 Section A
Poppet Type Bi-Directional Blocked A - B & B - A		SBV11 10 * C A318W **** 00	A318W 02-185376	SBV11-10-C Section A
Poppet Type Bi-Directional Blocked A - B & B - A		SBV11 10 * C0 A318W **** 00	A318W 02-185376	SBV11-10-0 Section A



CAUTION
Sandwich valve flow ratings are limited by the ratings of individual cartridges. Consult cartridge valve literature.

Solenoid Control & Load Control Functions

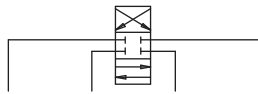

Function	Functional Symbol	Model Code	Hsg kit: model Part No.	Cartridge Cartridge Data Sheet Cavity
Solenoid Valve Spool Type Blocked A to B & B to A Normally Closed		SV4 10 * C A318W *** 00	A318W 02-185376	SV4-10-C Section A C-10-2
Solenoid Valve Spool Type Blocked A to B & B to A Normally Open		SV4 10 * O A318W *** 00	A318W 02-185376	SV4-10-O Section A
Solenoid 3-Way Selector on P		SV1 10 * 3 A326P *** 00	A326P 02-185353	SV1-10-3 Section A
Solenoid 3-Way Selector on P		SV4 10 * 3 A326P *** 00	A326P 02-185353	SV4-10-3 Section A
Manual Rotary Selector on P		MRV3 10 * K A236P 00	A236P 02 185353	MRV3-10-K-0 Section A

Load Control Functions

Counterbalance Valve On A Pilot from B		CBV* 10 * * A323A * 30/**** 00	A323A 02-185345	CBV*-10 Section H
Counterbalance Valve On B Pilot from A		CBV* 10 * * A323B * 30/**** 00	A323B 02-185346	CBV*-10 Section H
Counterbalance Valve On A & B Cross Piloted		CBV* 10 * * A323WA* 30/**** B * 30/**** 00 Refer to page L-23 for model code breakdown	A323W 02-185347	CBV*-10 qty 2 Section H

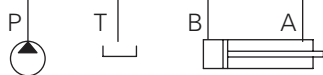

CAUTION

Sandwich valve flow ratings are limited by the ratings of individual cartridges. Consult cartridge valve literature.

Spacer / Blanking / Linking Plates

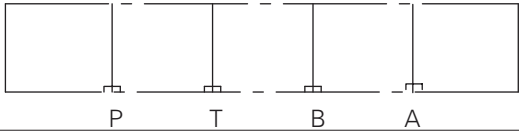
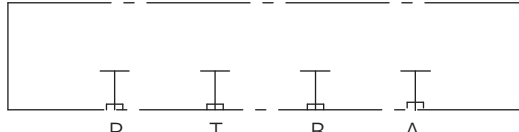
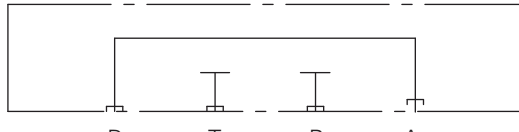
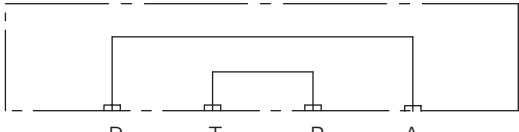
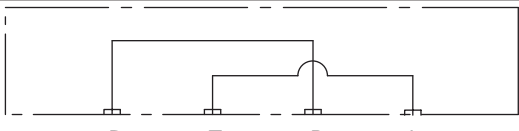
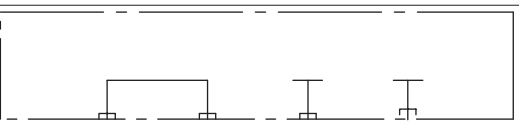
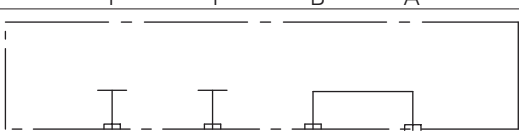
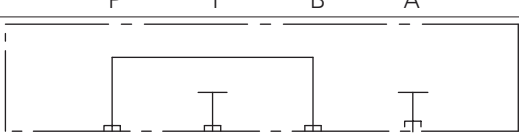
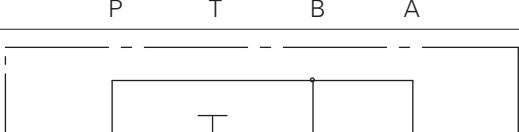
Function	Functional Symbol	Part Number
Spacer Plate 10 mm (.39) thick		02-185273 Note: O-Rings to be ordered separately See page Buna N O-Ring Kit 02-184951 Viton O-Ring Kit 02185282
Blanking Plate		02-185274 Note: O-Rings to be ordered separately See page Buna N O-Ring Kit 02-184951 Viton O-Ring Kit 02185282
Linking Plate P to A with B & T Blocked		02-185275 Note: O-Rings to be ordered separately See page Buna N O-Ring Kit 02-184951 Viton O-Ring Kit 02185282
Linking Plate P to A & B to T		02-185276 Note: O-Rings to be ordered separately See page Buna N O-Ring Kit 02-184951 Viton O-Ring Kit 02185282
Linking Plate P to B & A to T		02-185277 Note: O-Rings to be ordered separately See page Buna N O-Ring Kit 02-184951 Viton O-Ring Kit 02185282
Linking Plate P to A with A & B Blocked		02-185278 Note: O-Rings to be ordered separately See page Buna N O-Ring Kit 02-184951 Viton O-Ring Kit 02185282
Linking Plate P to A with P & T Blocked		02-185279 Note: O-Rings to be ordered separately See page Buna N O-Ring Kit 02-184951 Viton O-Ring Kit 02185282
Linking Plate P to B with A & T Blocked		02-185280 Note: O-Rings to be ordered separately See page Buna N O-Ring Kit 02-184951 Viton O-Ring Kit 02185282
Linking Plate P to A & B with T Blocked		02-185281 Note: O-Rings to be ordered separately See page Buna N O-Ring Kit 02-184951 Viton O-Ring Kit 02185282

Viton is a registered trademark of E.I.DuPont



CAUTION

Sandwich valve flow ratings are limited by the ratings of individual cartridges. Consult cartridge valve literature.

Model Codes

For Sandwich valve assemblies with two valves

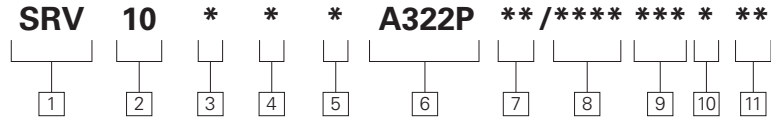

<p>1 Function SRV – Solenoid actuated relief valve</p>	<p>4 Style C – Normally closed O – Normally open</p>	<p>6 Housing Kit A322P – Solenoid Relief Valve</p>	<p>9 Voltage Range 12D – 24 VDC 24D – 24 VDC 115A – 115 VAC 230A – 230 VAC</p>
<p>2 Size 10 – 10 Size</p>	<p>5 Adjustment C – Cap F – Fixed I – Internal K – Knob S – Screw</p>	<p>7 Cracking Pressure Range 03 -3,5-20 bar (50-300 psi) 35 -17-240 bar (250-3500 psi)</p>	<p>10 Connector Type G – ISO 4400 DIN 43650 P – 1/2" NPT conduit W – Leadwire</p>
<p>3 Seals N – Buna-N V – Viton This Assembly includes an SV5-8 solenoid valve and an RV5-10 relief valve</p>		<p>8 Pressure Setting User requested setting in psi</p>	<p>11 Special Features 00 – None</p>

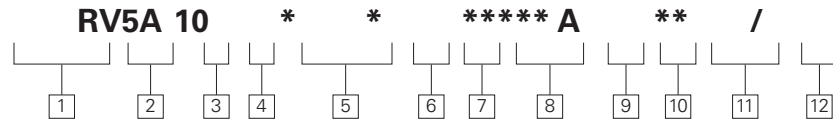

<p>1 Function RV5 – Relief valve</p>	<p>4 Adjustment C – Cap F – Fixed I – Internal K – Knob S – Screw</p>	<p>6 A Port Acted Upon</p>	<p>9 B Port Acted Upon</p>
<p>2 Size 10 – 10 Size</p>	<p>5 Housing Kit A312W – Dual A & B to T relief A321W – Cross port relief</p>	<p>7 Cracking Pressure Range 03 – 3,5-20 bar (50-300 psi) 20 – 7-140 bar (100-2000 psi) 35 – 17-240 bar (50-3500 psi)</p>	<p>10 Cracking Pressure Range 03 – 3,5-20 bar (50-300 psi) 20 – 7-140 bar (100-2000 psi) 35 – 17-240 bar (50-3500 psi)</p>
<p>3 Seals N – Buna-N V – Viton</p>		<p>8 Pressure Setting User requested setting in psi</p>	<p>11 Pressure Setting User requested setting in psi</p>
			<p>12 Special Features 00 – None</p>

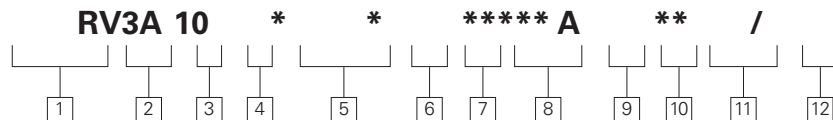

<p>1 Function RV1 – Relief valve</p>	<p>4 Adjustment C – Cap F – Fixed K – Knob S – Screw</p>	<p>6 A Port Acted Upon</p>	<p>9 B Port Acted Upon</p>
<p>2 Size 10 – 10 Size</p>	<p>5 Housing Kit A312W – Dual A & B to T relief A321W – Cross port relief</p>	<p>7 Cracking Pressure Range 03 -3,5-20 bar (50-300 psi) 09 -7-62 bar (100-900 psi) 18 -7-124 bar (250-1800 psi) 36 -35-250 bar (500-3600 psi)</p>	<p>10 Cracking Pressure 03 -3,5-20 bar (50-300 psi) 09 -7-62 bar (100-900 psi) 18 -7-124 bar (250-1800 psi) 36 -35-250 bar (500-3600 psi)</p>
<p>3 Seals N – Buna-N V – Viton</p>		<p>8 Pressure Setting User requested setting in psi</p>	<p>11 Pressure Setting User requested setting in psi</p>
			<p>12 Special Features 00 – None</p>

Model Codes

For Sandwich valve assemblies with two valves

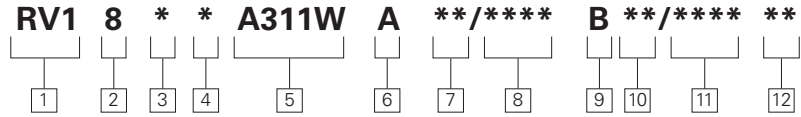

1 Function RV1 – Relief valve	4 Adjustment C – Cap K – Knob S – Screw	7 Cracking Pressure Range 03 -3, 5-20 bar (50-300 psi) 20 -41- 140 bar (100-900 psi) 36 -20-250 bar (300-3600 psi)	10 Cracking Pressure 03 -3, 5-20 bar (50-300 psi) 20 -41- 140 bar (100-900 psi) 36 -20-250 bar (300-3600 psi)
2 Size 8 – 8 Size	5 Housing Kit	8 Pressure Setting Specify in psi	11 Pressure Setting Specify in psi
3 Seals N – Buna-N V – Viton	6 A Port Acted Upon	9 B Port Acted Upon	12 Special Features 00 – None

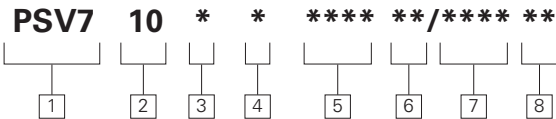

1 Function PSV2 – Pressure sequence valve	4 Adjustment C – Cap F – Fixed I – Internal K – Knob S – Screw	6 Cracking Pressure 02 - 3,5-10 bar (50-150 psi) 03 - 5-20 bar (75-300 psi) 05 - 7-30 bar (100-450 psi) 10 - 14-65 bar (200-950 psi) 18 - 20-125 bar (300-1800 psi)	7 Pressure Setting User requested setting in psi Note The other cartridge used in this assembly is a CV3-10-P-020
2 Size 10 – 10 Size	5 Housing Kit	8 Special Features 00 – None	
3 Seals N – Buna-N V – Viton			

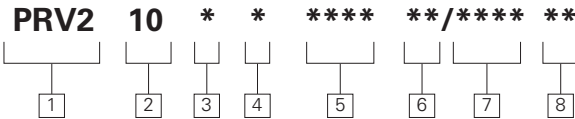

1 Function PRV2 – Pressure reducing valve	3 Seals N – Buna-N V – Viton	5 Housing Kit	7 Pressure Setting User requested setting in psi
2 Size 10 – 10 Size	4 Adjustment C – Cap F – Fixed I – Internal K – Knob S – Screw	6 Cracking Pressure 03 -3,5-20 bar (50-300 psi) 20 - 7-140 bar (100-2000 psi) 35 - 17-240 bar (250-3500 psi)	8 Special Features 00 – None

Model Codes

For Sandwich valve assemblies with two valves

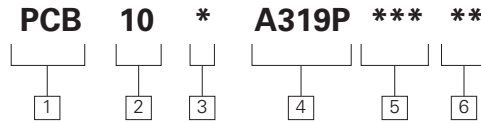

1 Function
PCB – Pressure compensator, bypass

2 Size
10 – 10 Size

3 Seals
N – Buna-N
V – Viton

4 Housing Kit
5 Differential Pressure
 (of DPS2-10-P-F cartridge)
005 – 0,3 bar (5 psi)
010 – 0,7 bar (10 psi)
020 – 1,38 bar (20 psi)
040 – 2,75 bar (40 psi)
080 – 5,5 bar (80 psi)
160 – 11,0 bar (160 psi)

6 Special Features
00 – None

Note
 The operating back pressure at port 3 (at A & B) must never be less than 1.3 times the spring set pressure

The other cartridge used in the assembly is a DSV2-8-B-0

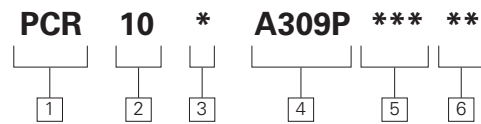

1 Function
PCR – Pressure compensator, restrictive

2 Size
10 – 10 Size

3 Seals
N – Buna-N
V – Viton

4 Housing Kit
5 Differential Pressure
 (of DPS2-10-F-F cartridge)
005 – 0,3 bar (5 psi)
010 – 0,7 bar (10 psi)
020 – 1,38 bar (20 psi)
040 – 2,75 bar (40 psi)
080 – 5,5 bar (80 psi)
160 – 11,0 bar (160 psi)

6 Special Features
00 – None

Note
 The operating back pressure at port 3 (at A & B) must never be less than 1.3 times the spring set pressure

The other cartridge used in the assembly is a DSV2-8-B-0

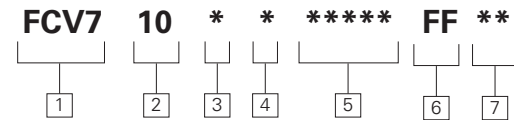

1 Function
FCV7 – Flow control valve

2 Size
10 – 10 Size

3 Seals
N – Buna-N
V – Viton

4 Adjustment
C – Cap
F – Fixed
K – Knob
S – Screw

5 Housing Kit
A314W – Meter out
A324W – Meter in

6 Control Flow Option
FF – Needle valve with free reverse flow

7 Special Features
00 – None

Model Codes

For Sandwich valve assemblies with two valves

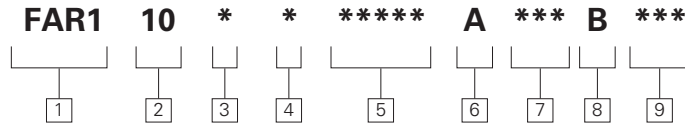

1 Function

FAR1 – Fully adjustable flow regulator

2 Size

10 – 10 Size

3 Seals

N – Buna-N
V – Viton

4 Adjustment

H – Calibrated handknob with locknut
K – Handknob with locknut
S – Screw with locknut

5 Housing Kit

A314W – Meter in
A324W – Meter out

6 A Port Acted Upon

7 Factory Set Flow Rate

Specify in tenths of a gallon per minute.
i.e. 025=2.5 USgpm

8 B Port Acted Upon

9 Factory Set Flow Rate

Specify in tenths of a gallon per minute.
i.e. 025=2.5 USgpm

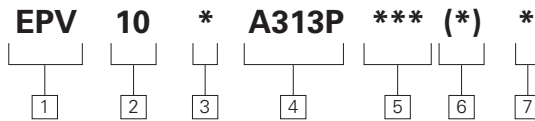

1 Function

EPV – Proportional flow control

2 Size

10 – 10 Size

3 Seals

N – Buna-N
V – Viton

4 Housing Kit

5 Voltage Range

12D – 24 VDC
24D – 24 VDC

6 Manual Override Option

Blank – No manual override
M – Pin type
S – Screw type

7 Coil Connector Type

F – Weatherpack
Q – Spade terminals
U – DIN 43650
W – Leadwire
Y – Metri-pak

Note

The other cartridge used in the assembly is a DPS2-10-F-F-0-160

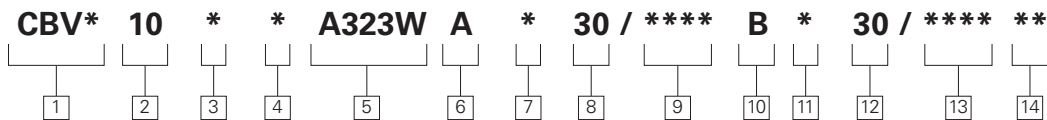

1 Pilot Ratio/function

CBV 1 – 4:1 CBV
CBV 2 – 10:1 CBV

2 Size

10 – 10 Size

3 Seals

N – Buna-N
V – Viton

4 Adjustment

C – Cap over screw
K – Handknob
S – Screw with locknut

5 Housing Kit

6 A Port Acted Upon

7 Free Flow Crack Pressure Range

A – 1,38 bar (20 psi) standard
B – 0,28 bar (4 psi) anti-cavitation

8 Pressure Range

30 – 62, 210 bar (900 – 3000 psi)

9 Pressure Setting

Specify in psi

10 B Port Acted Upon

11 Free Flow Crack Pressure Range

A – 1, 38 bar (20 psi) standard
B – 0, 28 bar (4 psi) anti-cavitation

12 Pressure Range

30 – 62, 210 bar (900 – 3000 psi)

13 Pressure Setting

Specify in psi

14 Special Features

00 – None

Dimensions

Spacer, blanking & linking plates

Spacer Plate 02-185273

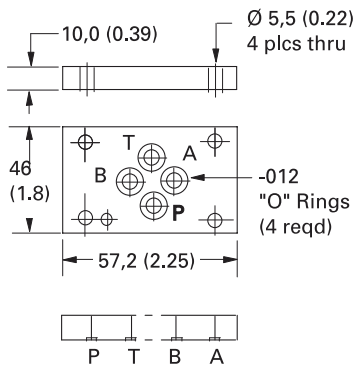

Blanking Plate 02-185274

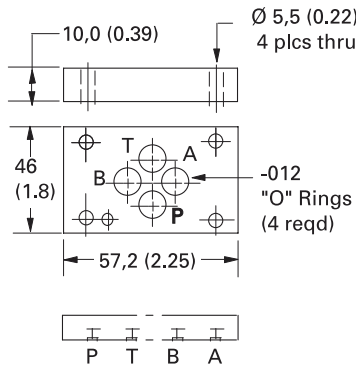

Linking Plate 02-185275

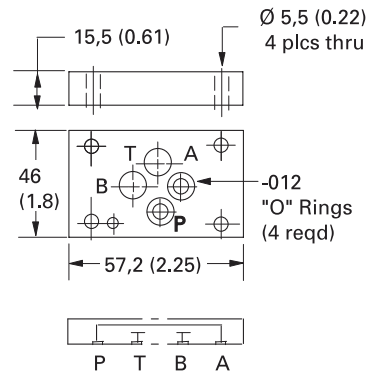

Linking Plate 02-185276

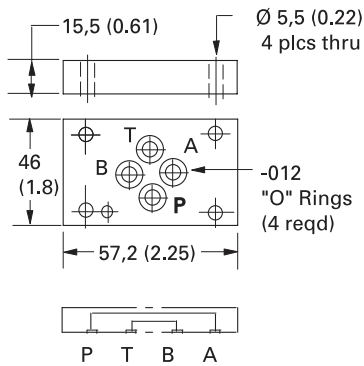

Linking Plate 02-185277

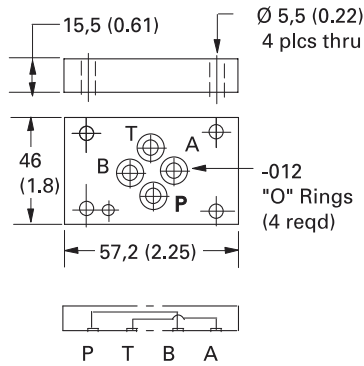

Linking Plate 02-185278

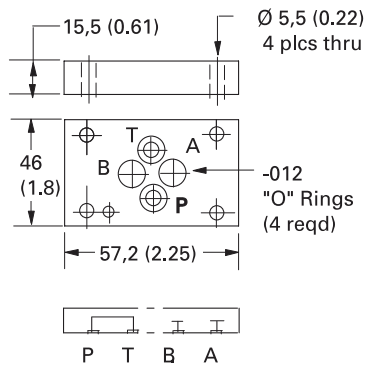

Linking Plate 02-185279

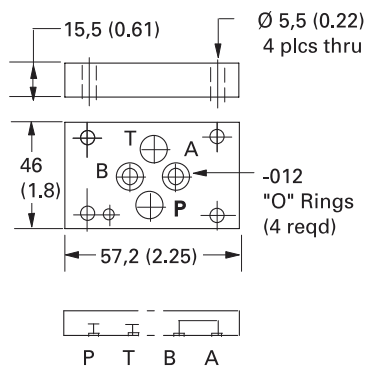

Linking Plate 02-185280

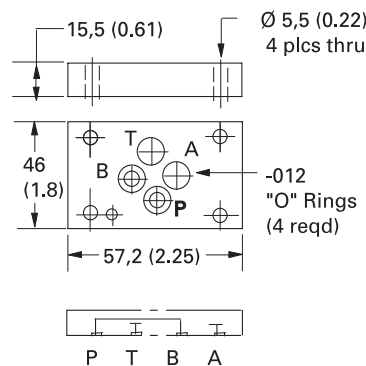

Linking Plate 02-185281

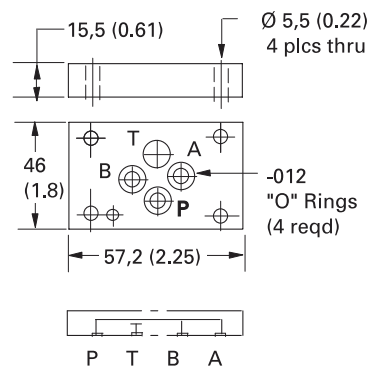

Dimensions

ISO 440103/CETOP3
Housing Kits

Dimensions

mm (inch)

A307A Housing Kit

Part Number 02-185354

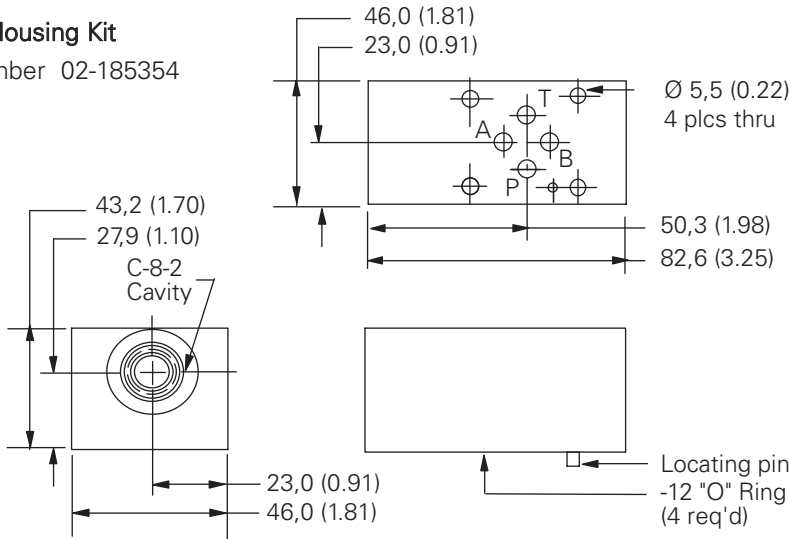

Cavity Porting

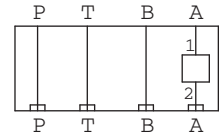

TYPICAL CARTRIDGES FUNCTION

TYPICAL CARTRIDGES	FUNCTION
CV3-8	Check valve on A, Free flow out

Torque cartridge in housing
34-40 Nm (25-30 ft. lbs)

A307B Housing Kit

Part Number 02-185355

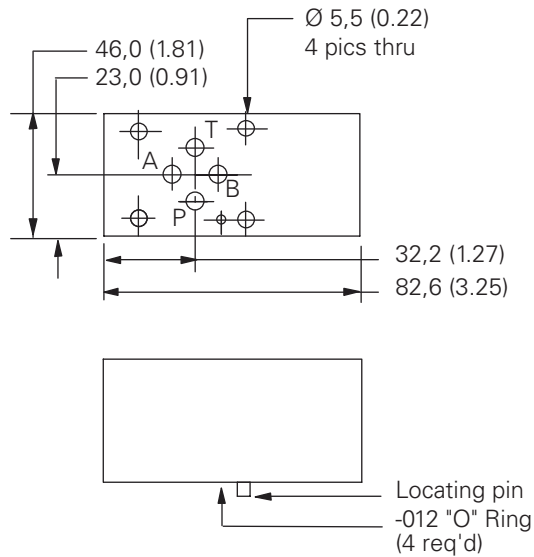

Cavity Porting

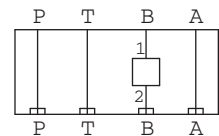

TYPICAL CARTRIDGES FUNCTION

TYPICAL CARTRIDGES	FUNCTION
CV3-8	Check valve on B, Free flow out

Torque cartridge in housing
34-40 Nm (25-30 ft. lbs)

Dimensions

ISO 440103/CETOP3
Housing Kits

Dimensions

mm (inch)

A307P Housing Kit

Part Number 02-185356

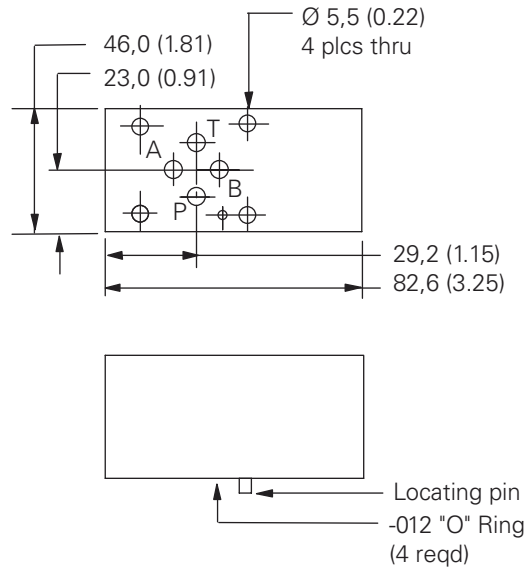

Cavity Porting

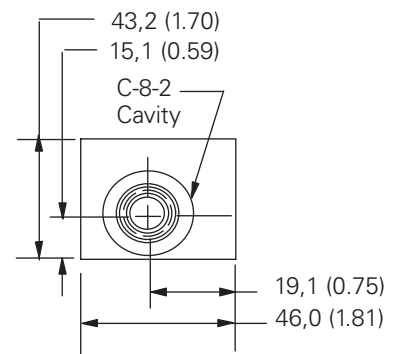
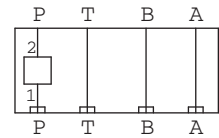

Torque cartridge in housing
34-40 Nm (25-30 ft. lbs)

TYPICAL CARTRIDGES	FUNCTION
CV3-8	Check valve on P

A308T Housing Kit

Part Number 02-185360

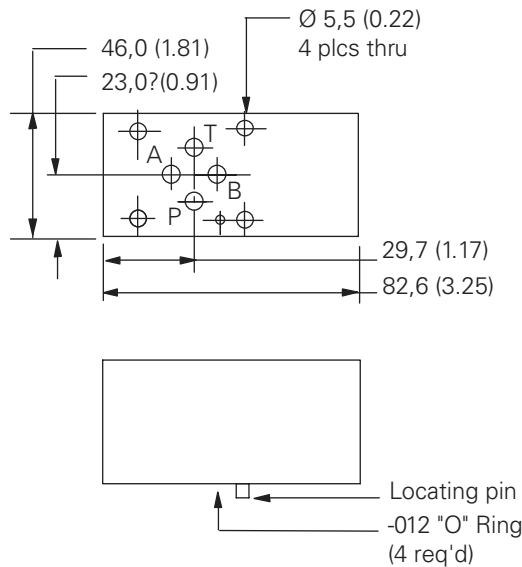

Cavity Porting

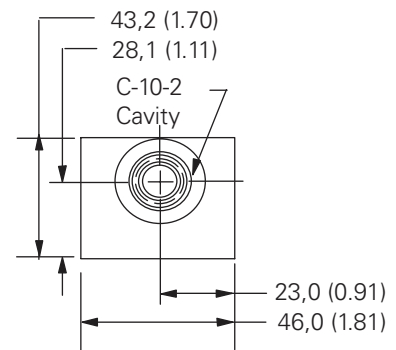
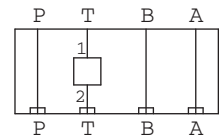

Torque cartridge in housing
48-54 Nm (35-40 ft. lbs)

TYPICAL CARTRIDGES	FUNCTION
CV3-10	Check valve on T

Dimensions

ISO 440103/CETOP3
Housing Kits

Dimensions

mm (inch)

A314A Housing Kit

Part Number 02-185367

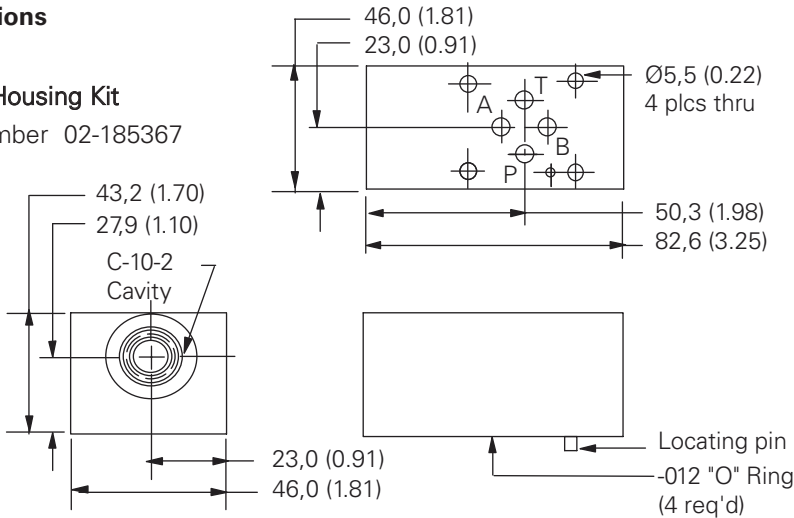

Cavity Porting

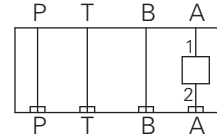

TYPICAL CARTRIDGES FUNCTION

TYPICAL CARTRIDGES	FUNCTION
CV3-10-P	Check valve on A, free flow out
FAR1-10	Flow regulator, pressure compensated and check, Meter in A
FCV7-10	Flow control and check, Meter out A
SBV11-10-C	Solenoid 2-way poppet type bi-directional load holding on A, normally closed
SBV11-10-O	Solenoid 2-way poppet type bi-directional load holding on A, normally open
SV3-10-C	Solenoid 2-way poppet type load holding on A, normally closed
SV3-10-O	Solenoid 2-way poppet type load holding on A, normally open

Torque cartridge in housing
48-54 Nm (35-40 ft. lbs)

Note
This housing may require the use of a spacer block 02-185273 depending upon cartridge valve selection.

A314B Housing Kit

Part Number 02-185368

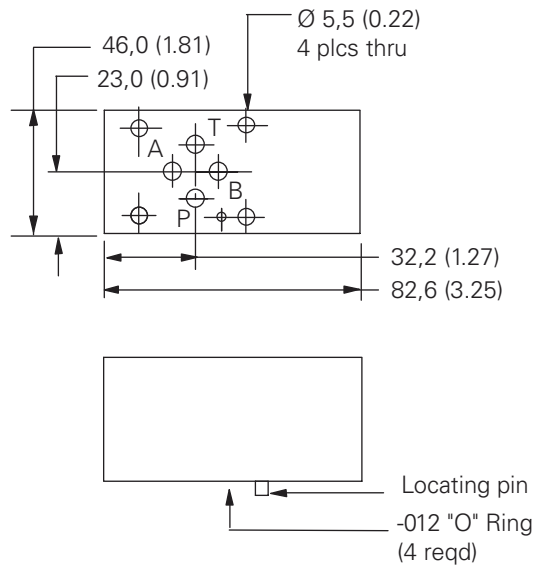

Cavity Porting

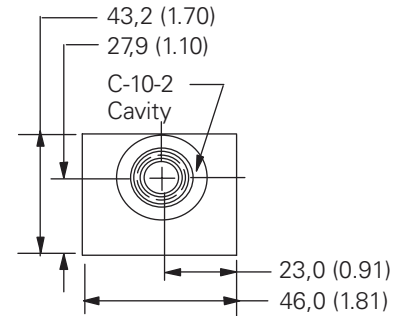
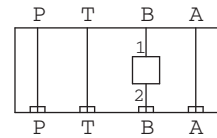

TYPICAL CARTRIDGES FUNCTION

TYPICAL CARTRIDGES	FUNCTION
CV3-10 *-P	Check valve on B, free flow out
FAR1-10	Flow regulator, pressure compensated and check, Meter in B
FCV7-10	Flow control and check, Meter out B
SBV11-10-C	Solenoid 2-way poppet type bi-directional load holding on B, normally closed
SBV11-10-O	Solenoid 2-way poppet type bi-directional load holding on B, normally open
SV3-10-C	Solenoid 2-way poppet type load holding on B, normally closed
SV3-10-O	Solenoid 2-way poppet type load holding on B, normally open

Torque cartridge in housing
48-54 Nm (35-40 ft. lbs)

NOTE
This housing may require the use of a spacer block 02-185273 depending upon cartridge valve selection.

Dimensions

ISO 440103/CETOP3
Housing Kits

Dimensions

mm (inch)

A315A Housing Kit

Part Number 02-185370

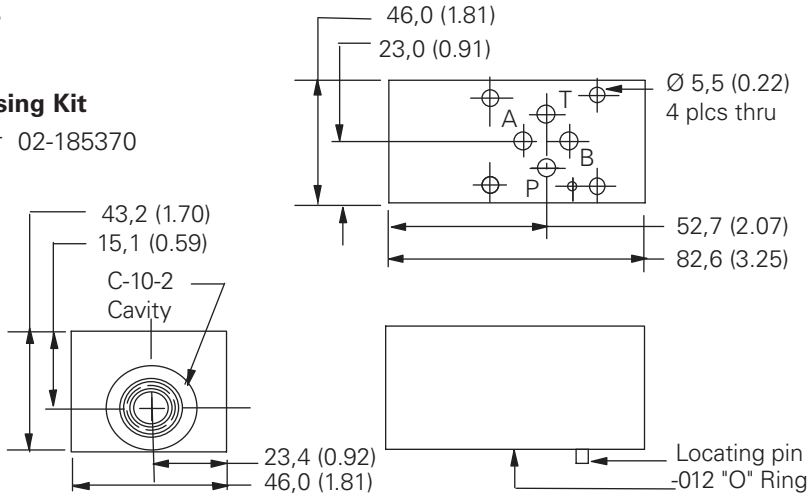

Cavity Porting

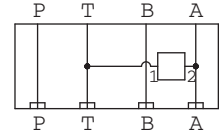

TYPICAL CARTRIDGES

FUNCTION

TYPICAL CARTRIDGES	FUNCTION
SV1-10-C	Solenoid 2-way poppet type unload A-T normally closed
SV3-10-C	Solenoid 2-way poppet type unload A-T normally closed
SV3-10-0	Solenoid 2-way poppet type unload A-T normally open
SV4-10-C	Solenoid 2-way spool type unload A-T normally closed
SV4-10-0	Solenoid 2-way spool type unload A-T normally open
SV5-10-0	Solenoid 2-way poppet type unload A-T normally open

Torque cartridge in housing
48-54 Nm (35-40 ft. lbs)

Note

This housing may require the use of a spacer block 02-185273 depending upon cartridge valve selection.

A315B Housing Kit

Part Number 02-185371

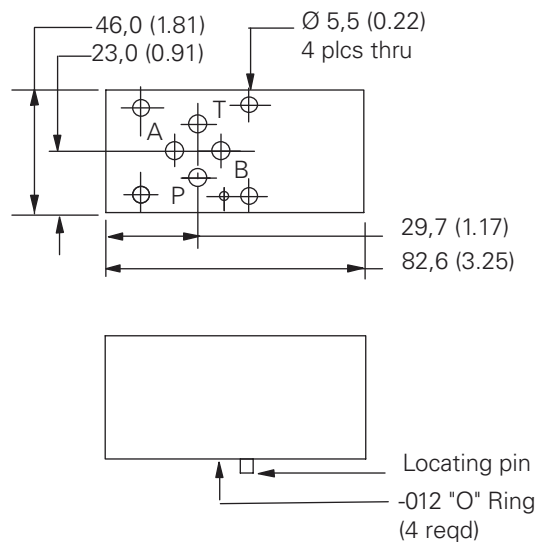

Cavity Porting

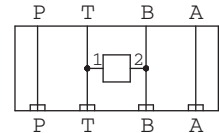

TYPICAL CARTRIDGES

FUNCTION

TYPICAL CARTRIDGES	FUNCTION
SV1-10-C	Solenoid 2-way poppet type unload B-T normally closed
SV3-10-C	Solenoid 2-way poppet type unload B-T normally closed
SV3-10-0	Solenoid 2-way poppet type unload B-T normally open
SV4-10-C	Solenoid 2-way spool type unload B-T normally closed
SV4-10-0	Solenoid 2-way spool type unload B-T normally open
SV5-10-0	Solenoid 2-way poppet type unload B-T normally open

Torque cartridge in housing
48-54 Nm (35-40 ft. lbs)

Note

This housing may require the use of a spacer block 02-185273 depending upon cartridge valve selection.

Dimensions

ISO 440103/CETOP3
Housing Kits

Dimensions

mm (inch)

A318W Housing Kit

Part Number 02-185376

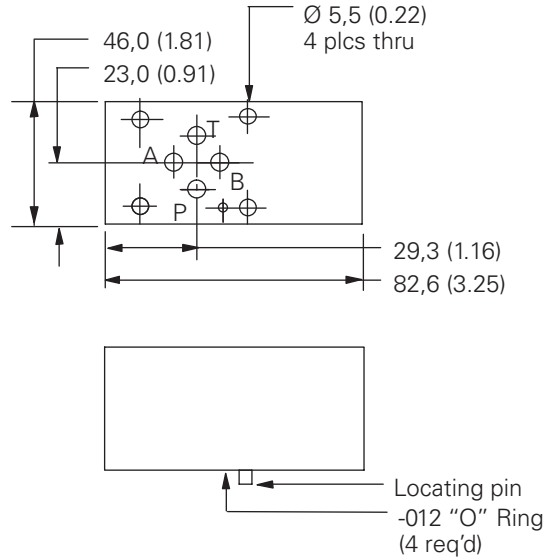

Cavity Porting

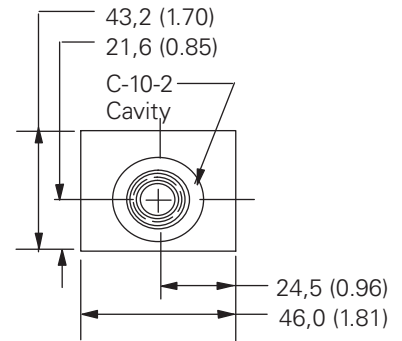
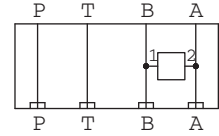

TYPICAL CARTRIDGES FUNCTION

TYPICAL CARTRIDGES	FUNCTION
SV4-10-C	Solenoid 2-way spool type locking A-B & B-A normally closed
SV4-10-0	Solenoid 2-way spool type locking A-B & B-A normally open
SV11-10-C	Solenoid 2-way poppet type bi-directional locking A-B & B-A normally closed
SV11-10-0	Solenoid 2-way poppet type bi-directional locking A-B & B-A normally open

Torque cartridge in housing
48-54 Nm (35-40 ft. lbs)

A321A Housing Kit

Part Number 02-185340

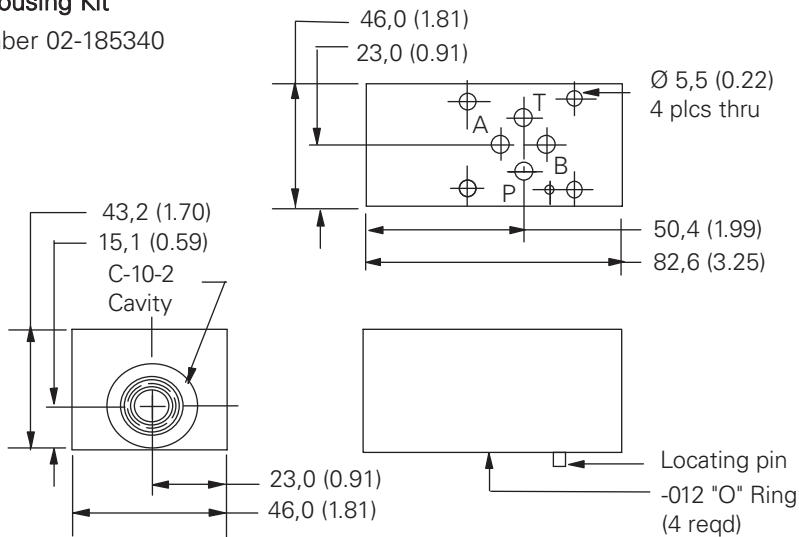

Cavity Porting

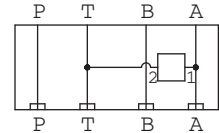

TYPICAL CARTRIDGES FUNCTION

TYPICAL CARTRIDGES	FUNCTION
ERV1-10	Proportional relief valve A-T
RV1-10	Relief valve A-T
RV5-10	Relief valve A-T

Torque cartridge in housing
48-54 Nm (35-40 ft. lbs)

Note
This housing may require the use of a spacer block 02-185273 depending upon cartridge valve selection.

Dimensions

ISO 440103/CETOP3
Housing Kits

Dimensions

mm (inch)

A324A Housing Kit

Part Number 02-185348

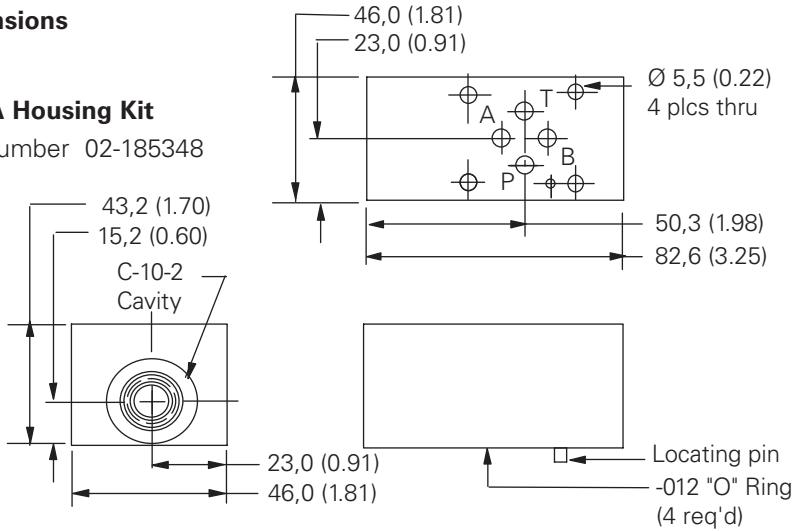

Cavity Porting

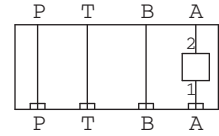

TYPICAL CARTRIDGES

FUNCTION

TYPICAL CARTRIDGES	FUNCTION
FAR1-10	Flow regulator pressure compensated and check, meter out A
FCV7-10	Flow control and check, meter in A
SV3-10-C	Solenoid 2-way poppet type blocking on A, normally closed
SV3-10-0	Solenoid 2-way poppet type blocking on A, normally open
SV4-10-C	Solenoid 2-way spool type blocking on A, normally closed
SV4-10-0	Solenoid 2-way spool type blocking on A, normally open

Torque cartridge in housing
48-54 Nm (35-40 ft. lbs)

Note

This housing may require the use of a spacer block 02-185273 depending upon cartridge valve selection.

A324B Housing Kit

Part Number 02-185349

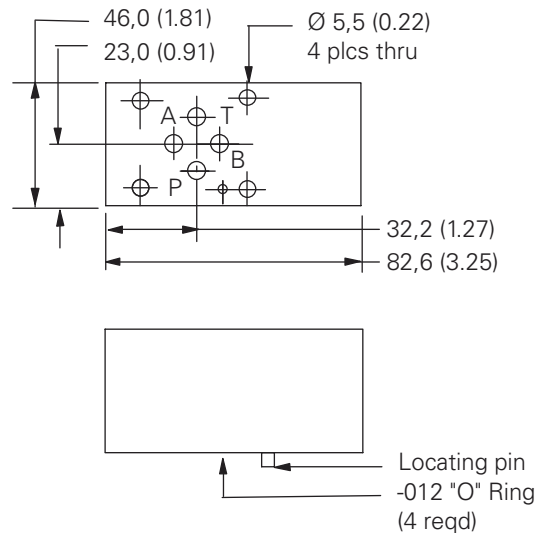

Cavity Porting

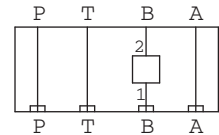

TYPICAL CARTRIDGES

FUNCTION

TYPICAL CARTRIDGES	FUNCTION
FAR1-10	Flow regulator pressure compensated and check, meter out A
FCV7-10	Flow control and check, meter in A
SV3-10-C	Solenoid 2-way poppet type blocking on A, normally closed
SV3-10-0	Solenoid 2-way poppet type blocking on A, normally open
SV4-10-C	Solenoid 2-way spool type blocking on A, normally closed
SV4-10-0	Solenoid 2-way spool type blocking on A, normally open

Torque cartridge in housing
48-54 Nm (35-40 ft. lbs)

Dimensions

ISO 440103/CETOP3
Housing Kits

Dimensions

mm (inch)

A307T Housing Kit

Part Number 02-185357

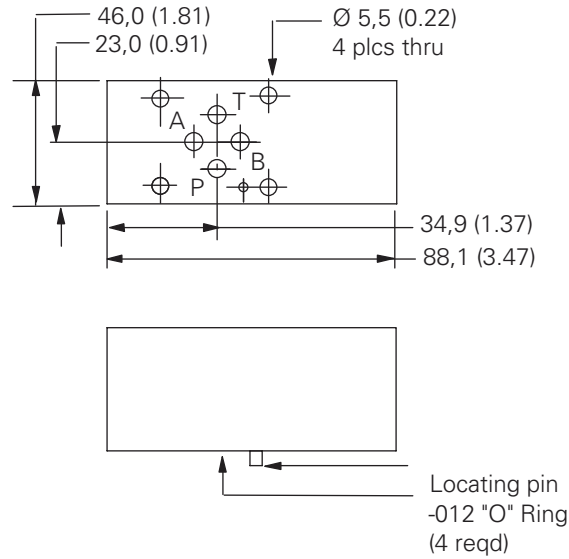

Cavity Porting

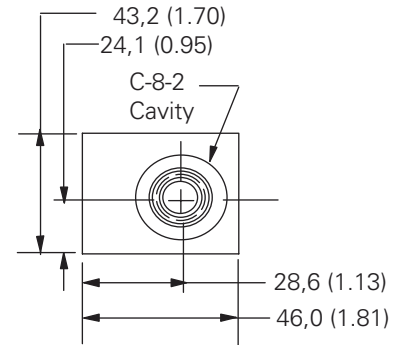
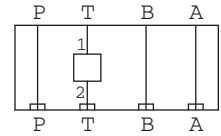

Torque cartridge in housing
34-40 Nm (25-30 ft. lbs)

TYPICAL CARTRIDGES	FUNCTION
--------------------	----------

CV3-8	Check valve on T
-------	------------------

A321B Housing Kit

Part Number 02-185341

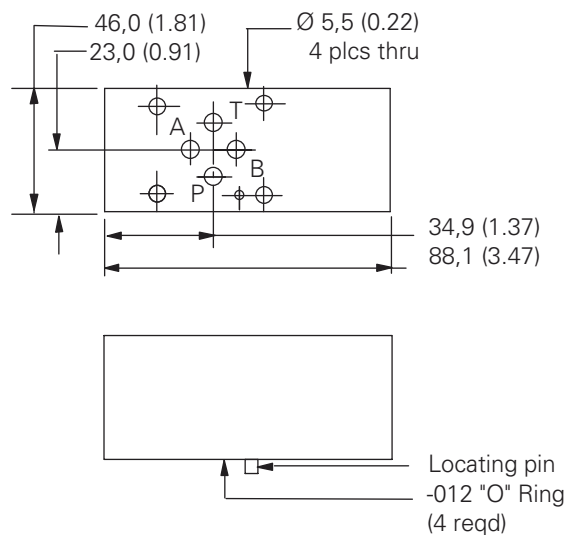

Cavity Porting

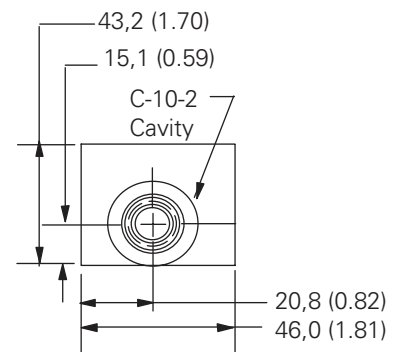
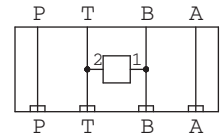

Torque cartridge in housing
48-54 Nm (35-40 ft. lbs)

TYPICAL CARTRIDGES	FUNCTION
--------------------	----------

ERV1-10	Proportional relief valve B-T
RV1-10	Relief valve B-T
RV5-20	Relief valve B-T

Dimensions

ISO 440103/CETOP3
Housing Kits

Dimensions

mm (inch)

A321P Housing Kit

Part Number 02-185342

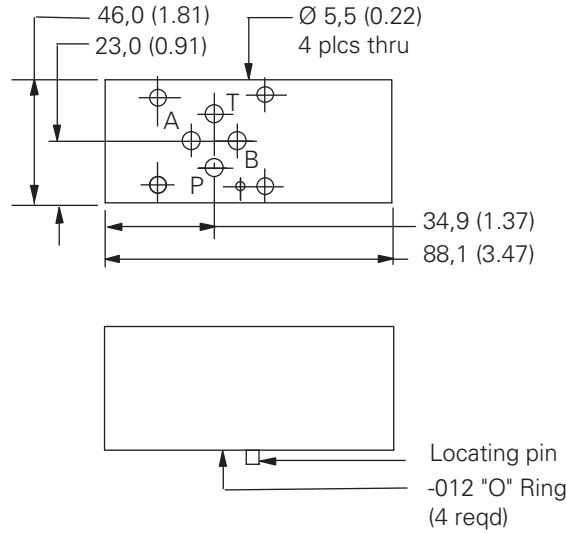

Cavity Porting

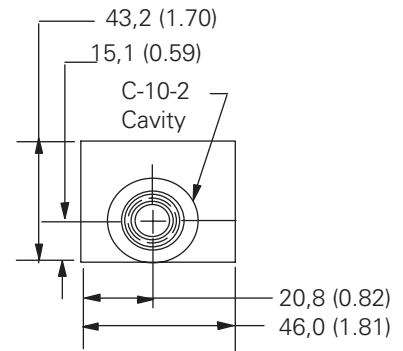
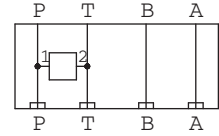

Torque cartridge in housing
48-54 Nm (35-40 ft. lbs)

Note
This housing may require the use of a spacer block 02-185273 depending upon cartridge valve selection.

TYPICAL CARTRIDGES FUNCTION

TYPICAL CARTRIDGES	FUNCTION
CV16-10-P-0-5	Anti-cavitation check P-T
ERV1-10	Proportional relief valve P-T
RV1-10	Relief valve P-T
RV5-10	Relief valve P-T

A324P Housing Kit

Part Number 02-185350

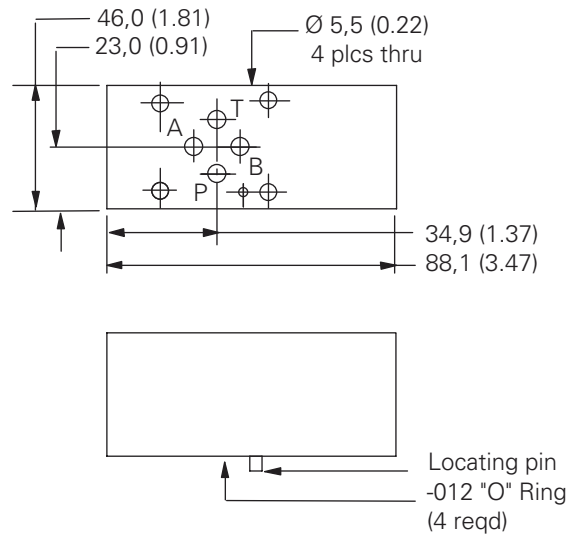

Cavity Porting

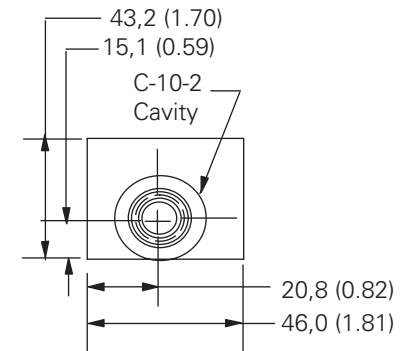
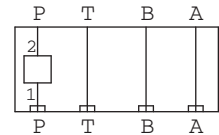

Torque cartridge in housing
48-54 Nm (35-40 ft. lbs)

Note
This housing may require the use of a spacer block 02-185273 depending upon cartridge valve selection.

TYPICAL CARTRIDGES FUNCTION

TYPICAL CARTRIDGES	FUNCTION
CV3-10	Check valve on P
FAR1-10	Flow regulator pressure compensated, meter in P
NV1-10	Flow control, meter in P

Dimensions

ISO 440103/CETOP3
Housing Kits

Dimensions

mm (inch)

A325P Housing Kit

Part Number 02-185352

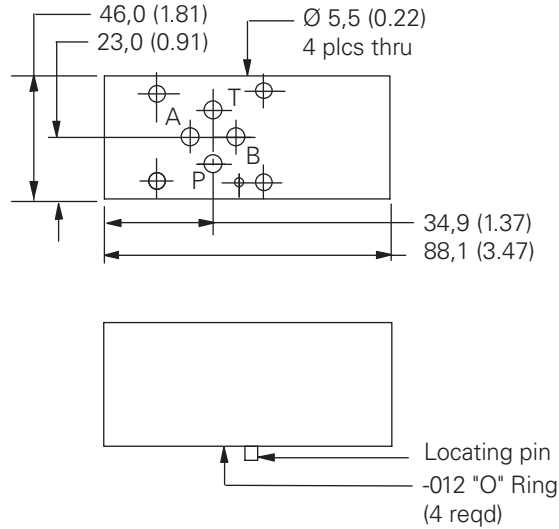

Cavity Porting

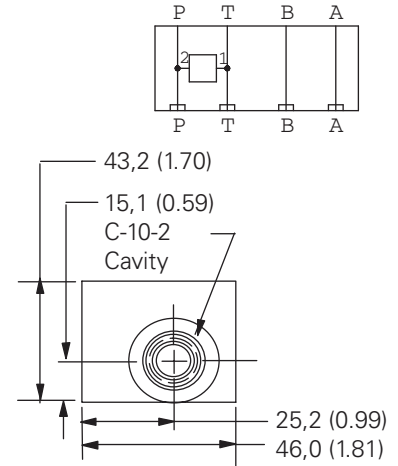

Torque cartridge in housing
48-54 Nm (35-40 ft. lbs)

Note

This housing may require the use of a spacer block 02-185273 depending upon cartridge valve selection.

TYPICAL CARTRIDGES FUNCTION

TYPICAL CARTRIDGES	FUNCTION
SV1-10-C	Solenoid 2-way poppet type P-T, normally closed
SV3-10-C	Solenoid 2-way poppet type P-T, normally closed
SV3-10-O	Solenoid 2-way poppet type P-T, normally open
SV4-10-C	Solenoid 2-way spool type P-T, normally closed
SV4-10-O	Solenoid 2-way spool type P-T, normally open
SV5-10-O	Solenoid 2-way poppet type P-T, normally open

A323A Housing Kit

Part Number 02-185345

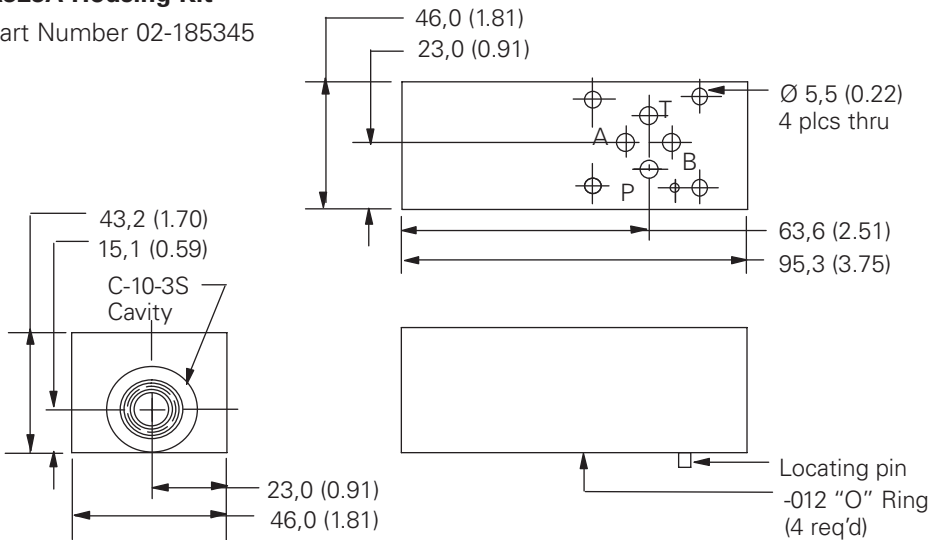

Cavity Porting

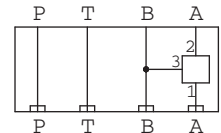

Torque cartridge in housing
48-54 Nm (35-40 ft. lbs)

Note

This housing may require the use of a spacer block 02-185273 depending upon cartridge valve selection.

TYPICAL CARTRIDGES FUNCTION

TYPICAL CARTRIDGES	FUNCTION
CBV*-10	Counterbalance valve on A, pilot from B
POC1-10	Pilot operated check valve on A, pilot from B

Dimensions

ISO 440103/CETOP3
Housing Kits

Dimensions

mm (inch)

A323B Housing Kit

Part Number 02-185346

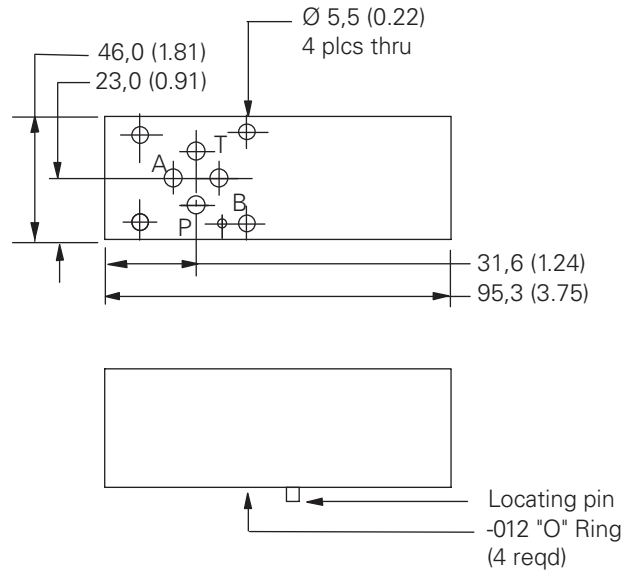

Cavity Porting

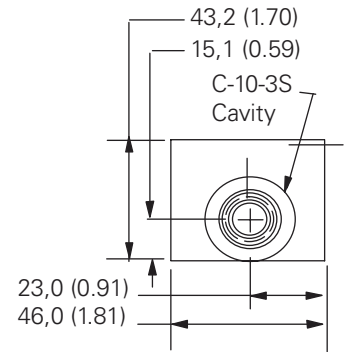
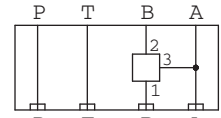

TYPICAL CARTRIDGES FUNCTION

TYPICAL CARTRIDGES	FUNCTION
CBV*-10	Counterbalance valve on B, pilot from A
POC1-10	Pilot operated check valve on B, pilot from A

Torque cartridge in housing
48-54 Nm (35-40 ft. lbs)

A311W Housing Kit

Part Number 02-185364

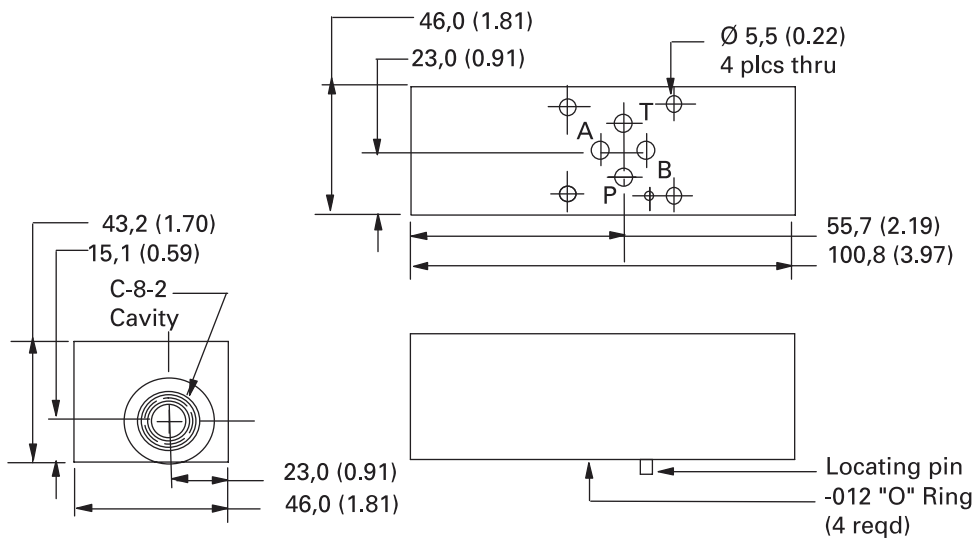

Cavity Porting

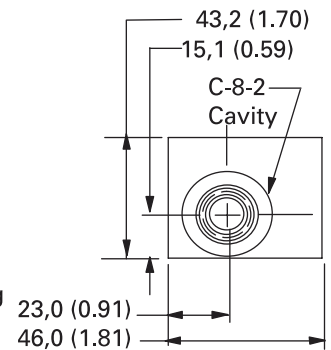
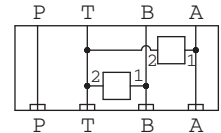

TYPICAL CARTRIDGES FUNCTION

TYPICAL CARTRIDGES	FUNCTION
RV1-8	Dual relief valve A-T, B-T

Torque cartridge in housing
34-40 Nm (25-30 ft. lbs)

Dimensions

ISO 440103/CETOP3
Housing Kits

Dimensions

mm (inch)

A312W Housing Kit

Part Number 02-185365

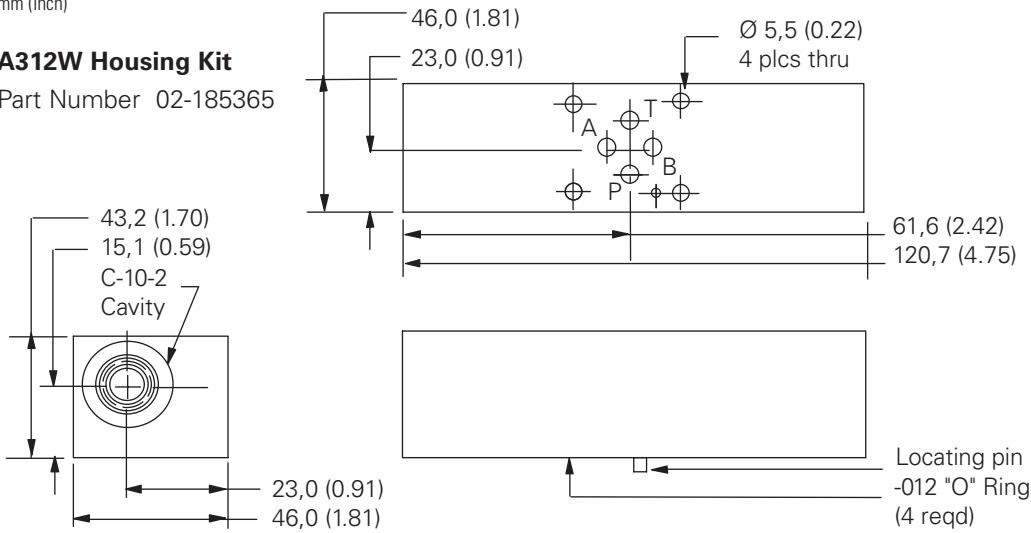

TYPICAL CARTRIDGES FUNCTION

TYPICAL CARTRIDGES	FUNCTION
RV1-10	Dual relief valve A-T, B-T
RV5-10	Dual relief valve A-T, B-T

Cavity Porting

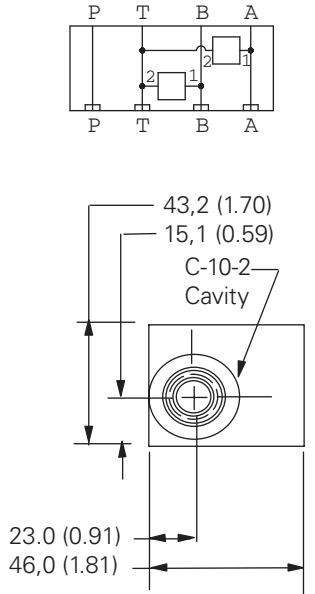

Torque cartridge in housing
48-54 Nm (35-40 ft. lbs)

A314W Housing Kit

Part Number 02-185369

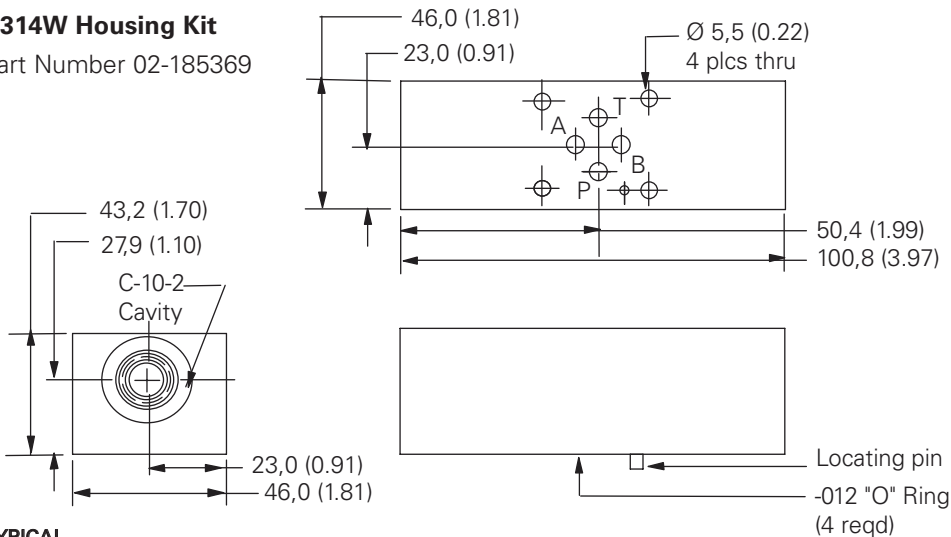

TYPICAL CARTRIDGES FUNCTION

TYPICAL CARTRIDGES	FUNCTION
FAR1-10	Flow regulator pressure compensated and check, meter in A & B
FCV7-10	Flow control and check, meter out A & B
SBV11-10-C	Solenoid 2-way poppet type bi-directional load holding on A & B, normally closed
SBV11-10-O	Solenoid 2-way poppet type bi-directional load holding on A & B, normally open
SV3-10-C	Solenoid 2 way poppet type load holding on A & B, normally closed
SV3-10-O	Solenoid 2 way poppet type load holding on A & B, normally open

Cavity Porting

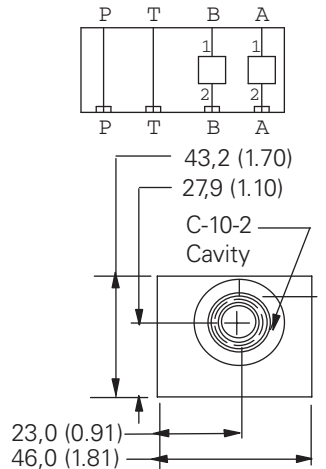

Torque cartridge in housing
48-54 Nm (35-40 ft. lbs)

Note
This housing may require the use of a spacer block 02-185273 depending on cartridge valve selection.

Dimensions

ISO 440103/CETOP3
Housing Kits

Dimensions

mm (inch)

A324W Housing Kit

Part Number 02-185351

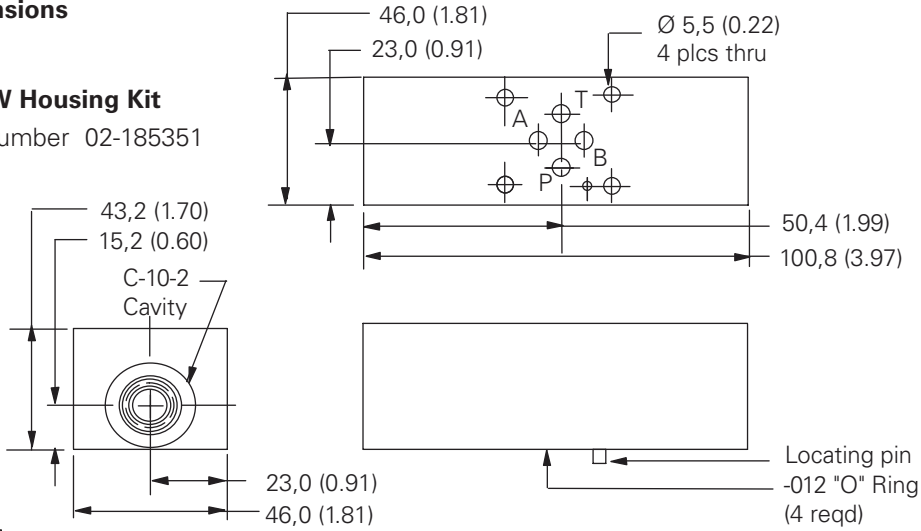

Cavity Porting

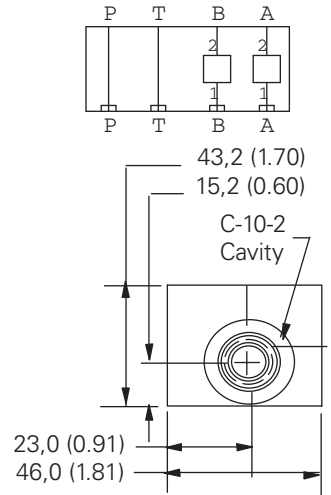

TYPICAL CARTRIDGES

FUNCTION

TYPICAL CARTRIDGES	FUNCTION
FAR1-10	Flow regulator pressure compensated and check, meter out A & B
FCV7-10	Flow control & check, meter in A & B
SV3-10-C	Solenoid 2-way poppet type blocking on A & B normally closed
SV3-10-O	Solenoid 2-way poppet type blocking on A & B normally open
SV4-10-C	Solenoid 2-way spool type blocking on A & B normally closed
SV4-10-O	Solenoid 2-way spool type blocking on A & B normally open

Torque cartridge in housing
48-54 Nm (35-40 ft. lbs)

A326P Housing Kit

Part Number 02-185353

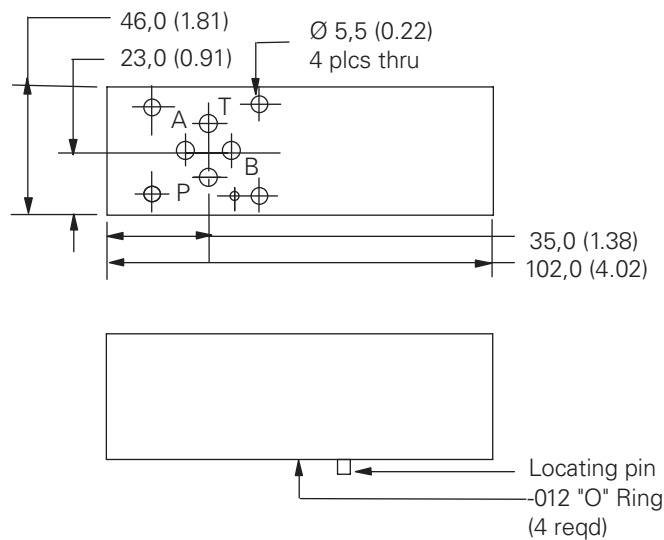

Cavity Porting

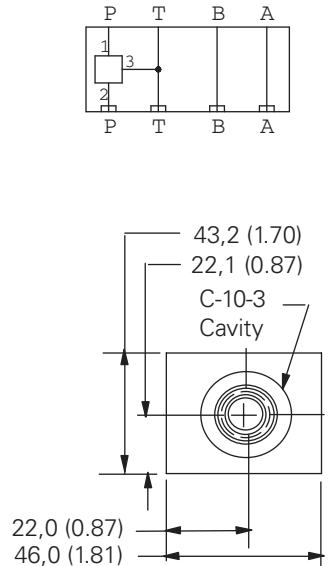

TYPICAL CARTRIDGES

FUNCTION

TYPICAL CARTRIDGES	FUNCTION
MRV3-10-K-0	Manual rotary selector on P
PRV2-10	Reducing valve (P) drained to T
SV1-10-3	Solenoid 3-way selector on P
SV4-10-3	Solenoid 3-way selector on P

Torque cartridge in housing
48-54 Nm (35-40 ft. lbs)

Dimensions

ISO 440103/CETOP3
Housing Kits

Dimensions

mm (inch)

A309W Housing Kit

Part Number 02-185361

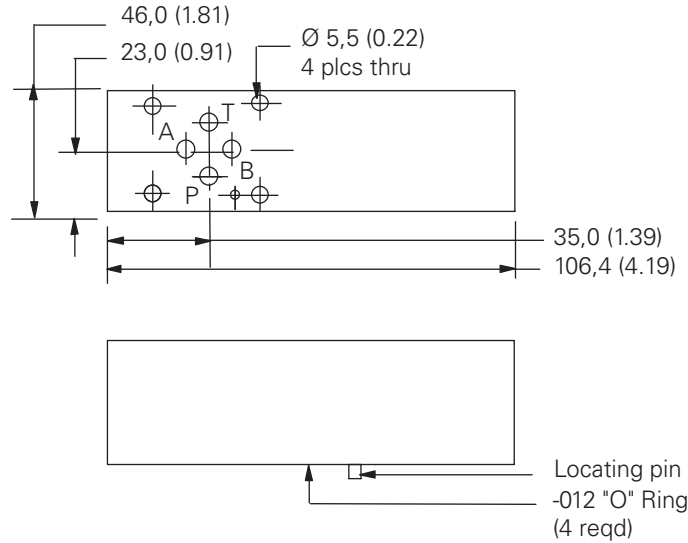

Cavity Porting

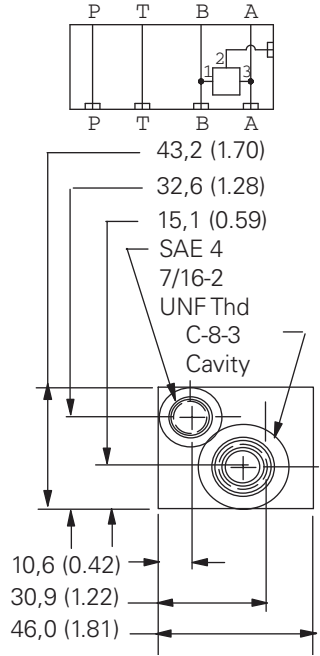

Torque cartridge in housing
34-40 Nm (25-30 ft. lbs)

TYPICAL CARTRIDGES FUNCTION

DSV2-8-B-0	Shuttle valve A & B Output external
------------	-------------------------------------

A322P Housing Kit

Part Number 02-185344

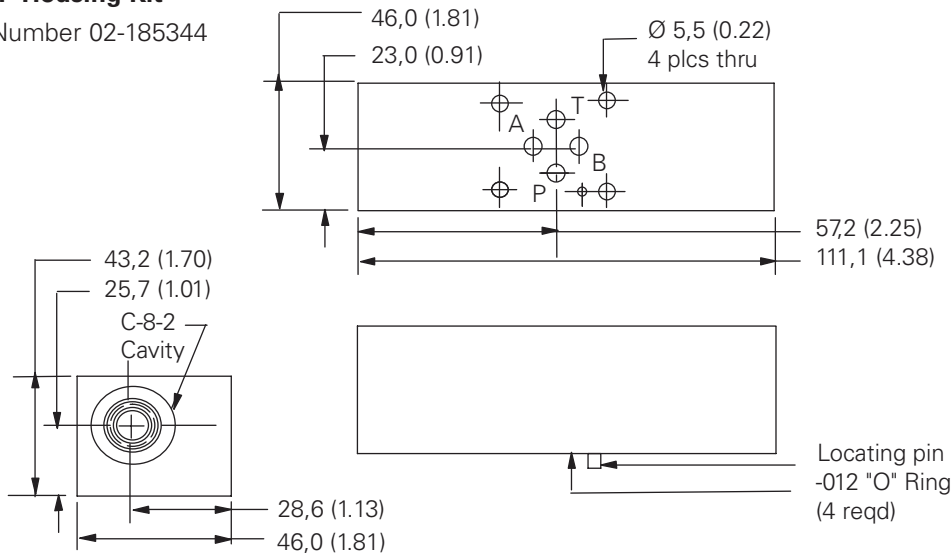

Cavity Porting

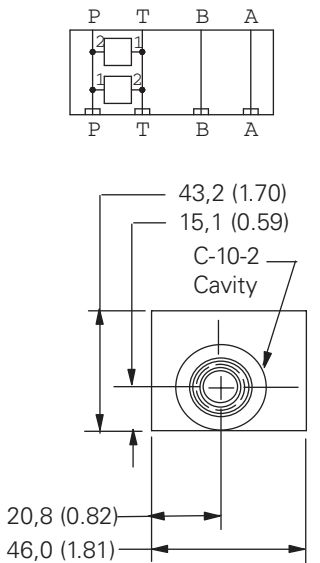

Torque cartridge in housing
C-8-2 34-40 Nm (25-30 ft. lbs)
C-10-2 48-54 Nm (35-40 ft. lbs)

TYPICAL CARTRIDGES FUNCTION

SV5-8-0 & RV1-10	Solenoid control relief valve P-T, normally open
SV5-8-C & RV1-10	Solenoid control relief valve P-T, normally closed

Dimensions

ISO 440103/CETOP3
Housing Kits

Dimensions

mm (inch)

A316P Housing Kit

Part Number 02-185374

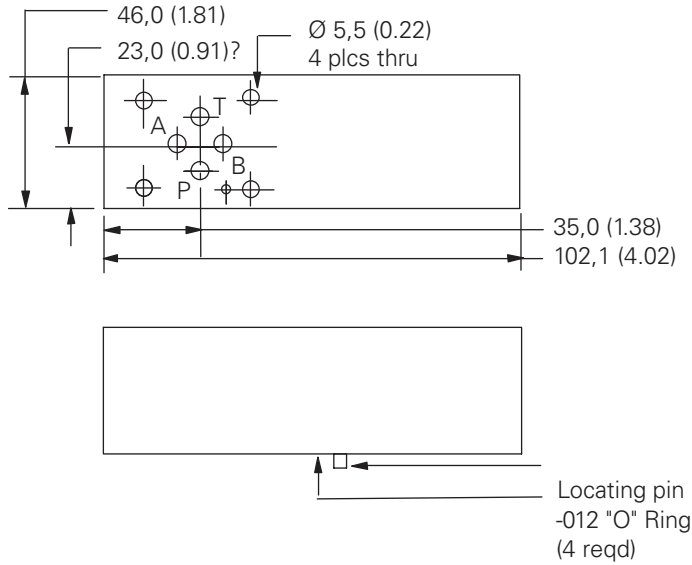

Cavity Porting

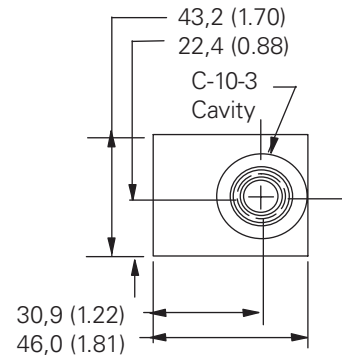
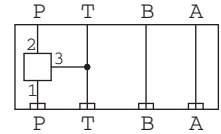

Torque cartridge in housing
48-54 Nm (35-40 ft. lbs)

TYPICAL CARTRIDGES FUNCTION

TYPICAL CARTRIDGES	FUNCTION
PSV7-10	Sequence valve in to P

A320T Housing Kit

Part Number 02-185379

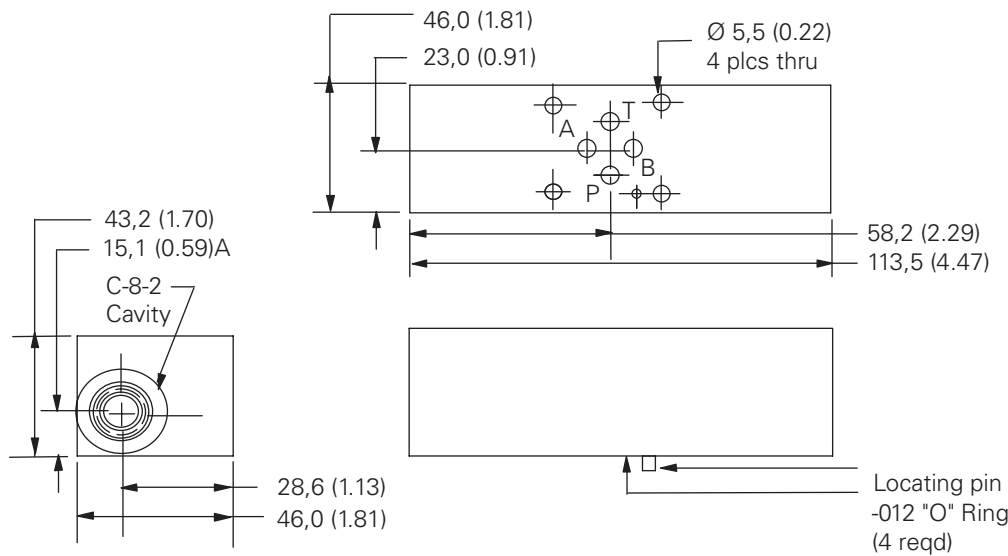

Cavity Porting

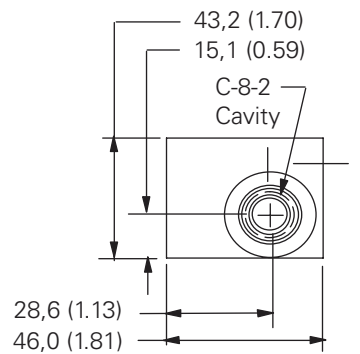
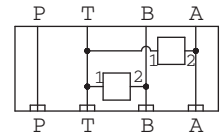

Torque cartridge in housing
34-40 Nm (25-30 ft. lbs)

TYPICAL CARTRIDGES FUNCTION

TYPICAL CARTRIDGES	FUNCTION
CV3-8	Check valve on T to A & B

Dimensions

ISO 440103/CETOP3
Housing Kits

Dimensions

mm (inch)

A321W Housing Kit

Part Number 02-185343

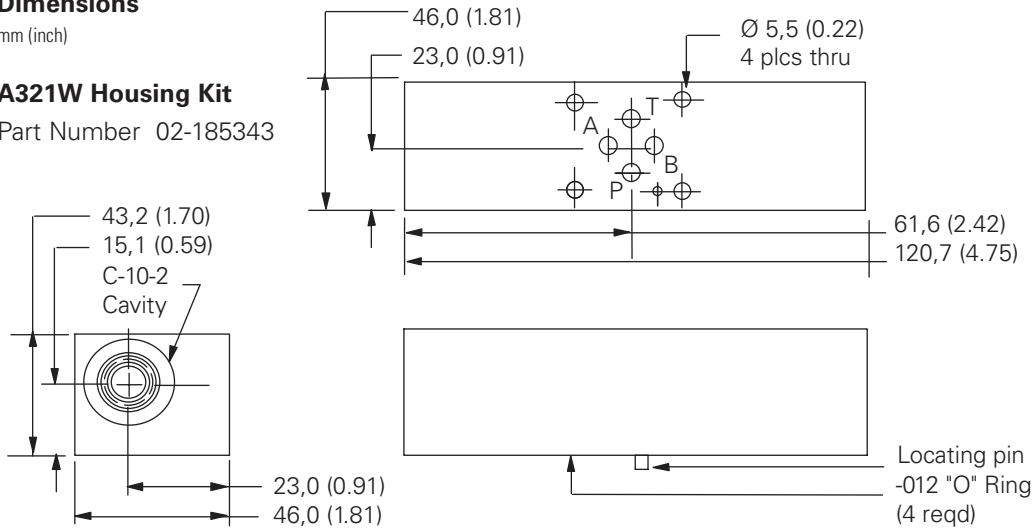

Cavity Porting

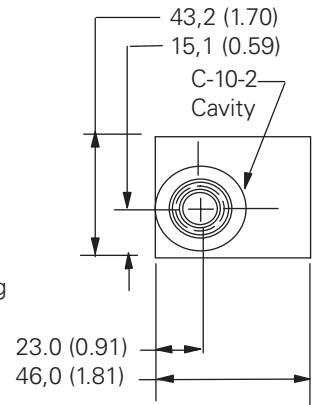
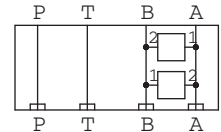

Torque cartridge in housing
48-54 Nm (35-40 ft. lbs)

TYPICAL CARTRIDGES FUNCTION

TYPICAL CARTRIDGES	FUNCTION
RV1-10	Cross port relief valve A & B
RV5-10	Cross port relief valve A & B

A323W Housing Kit

Part Number 02-185347

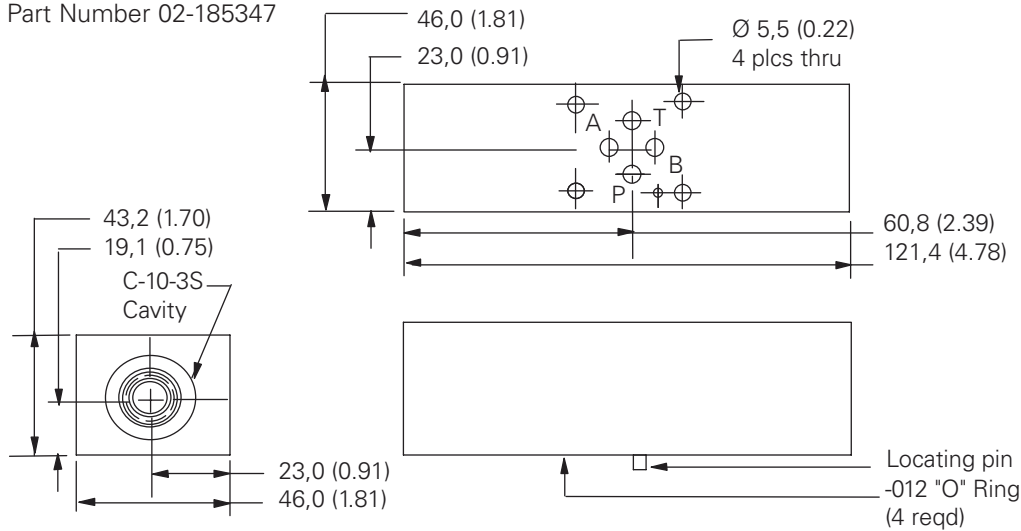

Cavity Porting

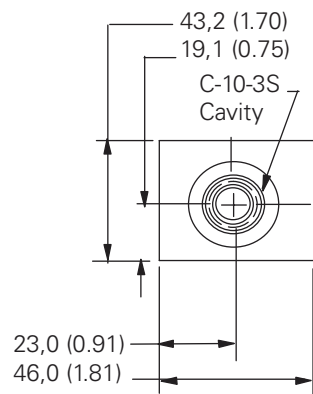
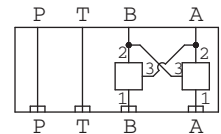

Torque cartridge in housing
48-54 Nm (35-40 ft. lbs)

TYPICAL CARTRIDGES FUNCTION

TYPICAL CARTRIDGES	FUNCTION
CBV*-10	Counterbalance valve on A & B cross piloted
POC1-10	Pilot operated check valve on A & B cross piloted

Dimensions

ISO 440103/CETOP3
Housing Kits

Dimensions

mm (inch)

A317T Housing Kit

Part Number 02-185375

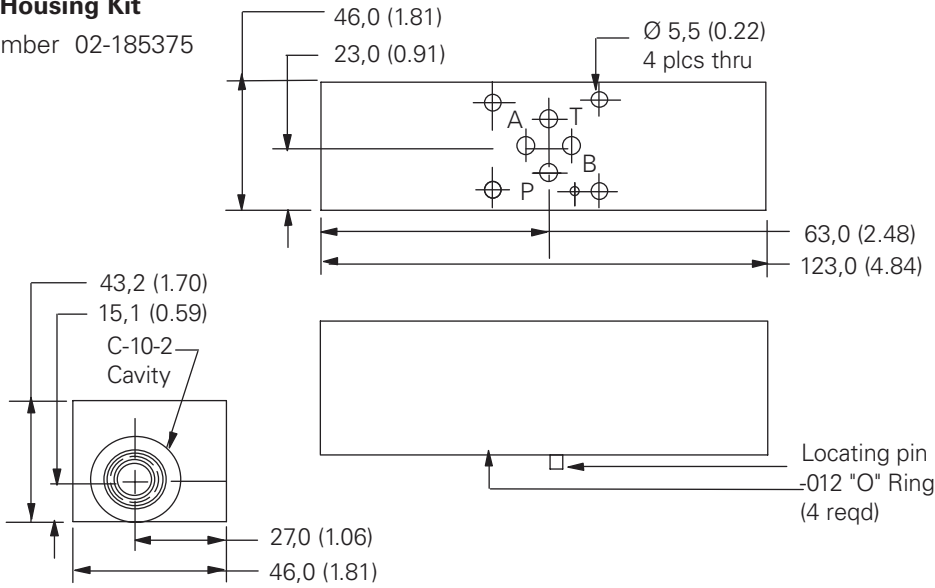

Cavity Porting

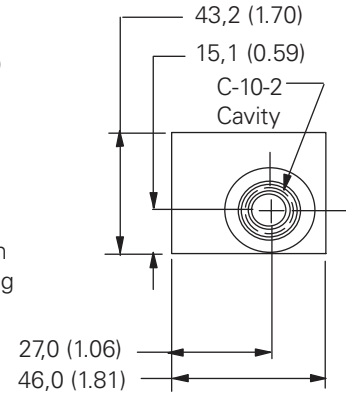
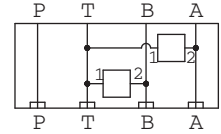

TYPICAL CARTRIDGES FUNCTION

TYPICAL CARTRIDGES	FUNCTION
CV3-10	Check valve on T to A & B
SV1-10-C	Solenoid 2-way poppet type unload A & B-T, normally closed
SV3-10-C	Solenoid 2-way poppet type unload A & B-T, normally closed
SV3-10-0	Solenoid 2-way poppet type unload A & B-T, normally open
SV4-10-C	Solenoid 2-way spool type unload A & B-T, normally closed
SV4-10-0	Solenoid 2-way spool type unload A & B-T, normally open
SV5-10-0	Solenoid 2-way poppet type unload A & B-T, normally open

Torque cartridge in housing
48-54 Nm (35-40 ft. lbs)

Note

This housing may require the use of a spacer block 02-185273 depending upon cartridge valve selection.

A310A Housing Kit

Part Number 02-185362

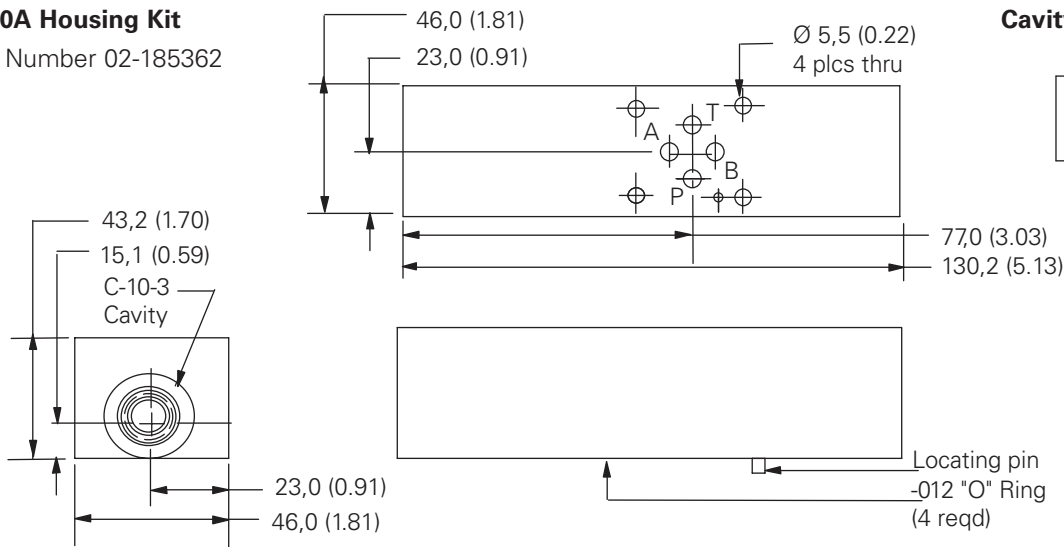

Cavity Porting

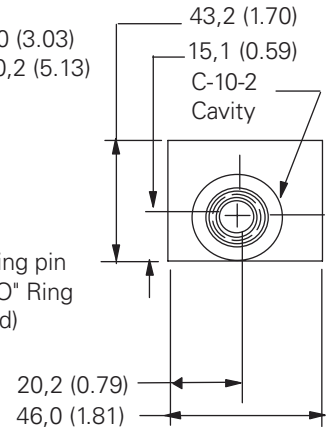
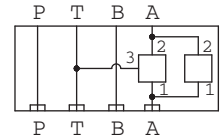

TYPICAL CARTRIDGES FUNCTION

TYPICAL CARTRIDGES	FUNCTION
PRV2-10 & CV3-10-P-3	Reducing on A drained to T reverse free flow check

Note

This housing may require the use of a spacer block 02-185273 depending upon cartridge valve selection.

Torque cartridge in housing
48-54 Nm (35-40 ft. lbs)

Dimensions

ISO 440103/CETOP3
Housing Kits

Dimensions

mm (inch)

A310B Housing Kit

Part Number 02-185363

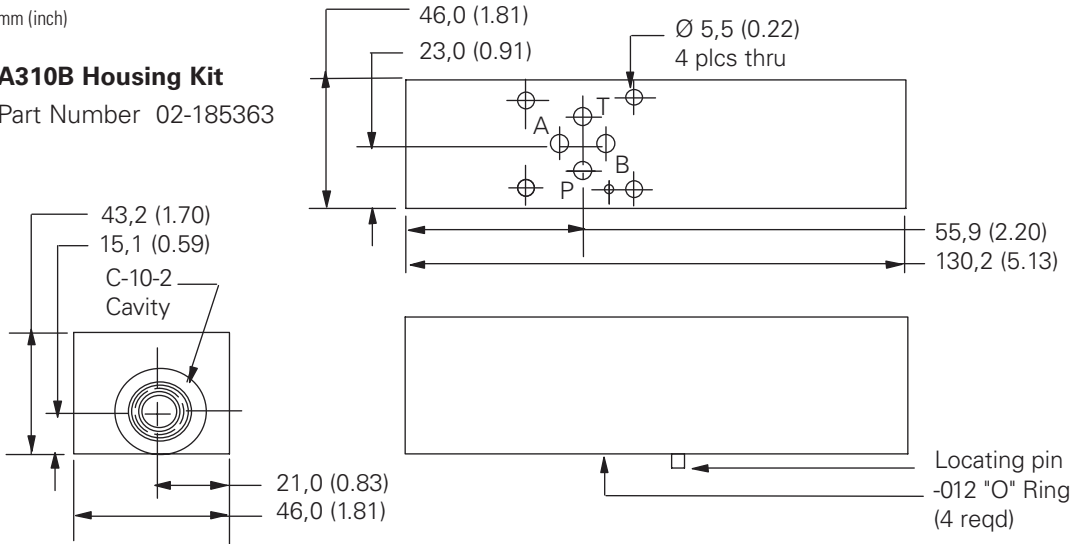

Cavity Porting

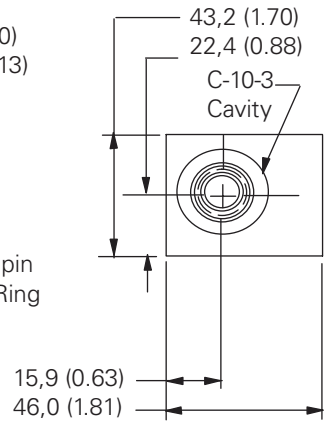
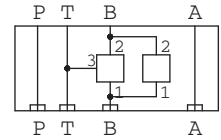

TYPICAL CARTRIDGES	FUNCTION
--------------------	----------

PRV7-10 & CV3-10-P-0-3	Reducing on B drained to T reverse free flow check
------------------------	--

Torque cartridge in housing
48-54 Nm (35-40 ft. lbs)

A316A Housing Kit

Part Number 02-185372

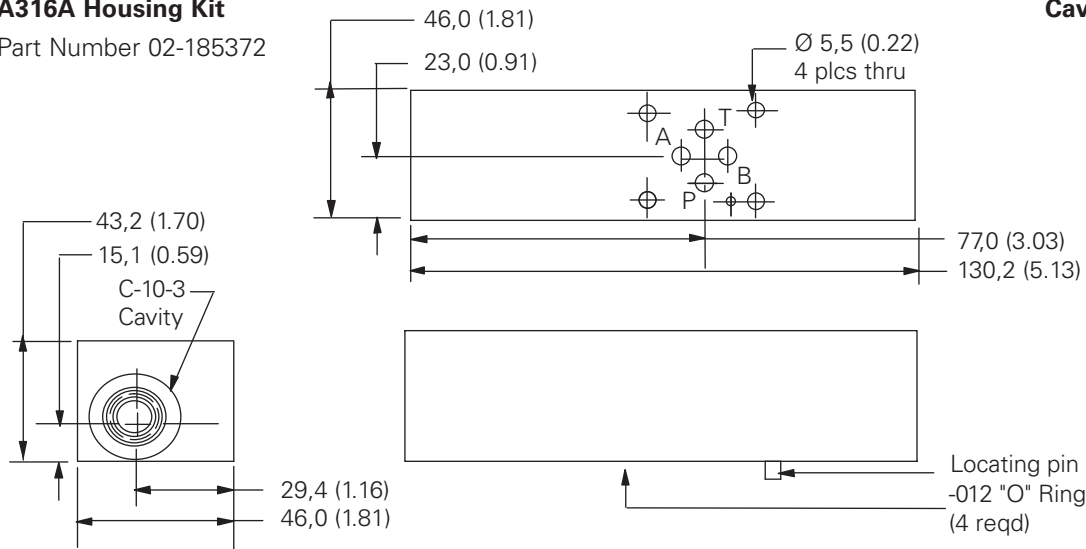

Cavity Porting

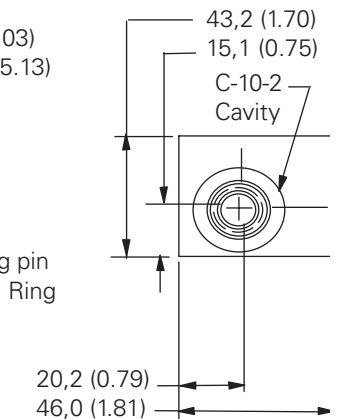
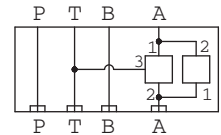

TYPICAL CARTRIDGES	FUNCTION
--------------------	----------

PSV7-10 & CV3-10-P-0-3	Sequence valve in to A reverse free flow check
------------------------	--

Torque cartridge in housing
48-54 Nm (35-40 ft. lbs)

Dimensions

ISO 440103/CETOP3
Housing Kits

Dimensions

mm (inch)

A316B Housing Kit

Part Number 02-185373

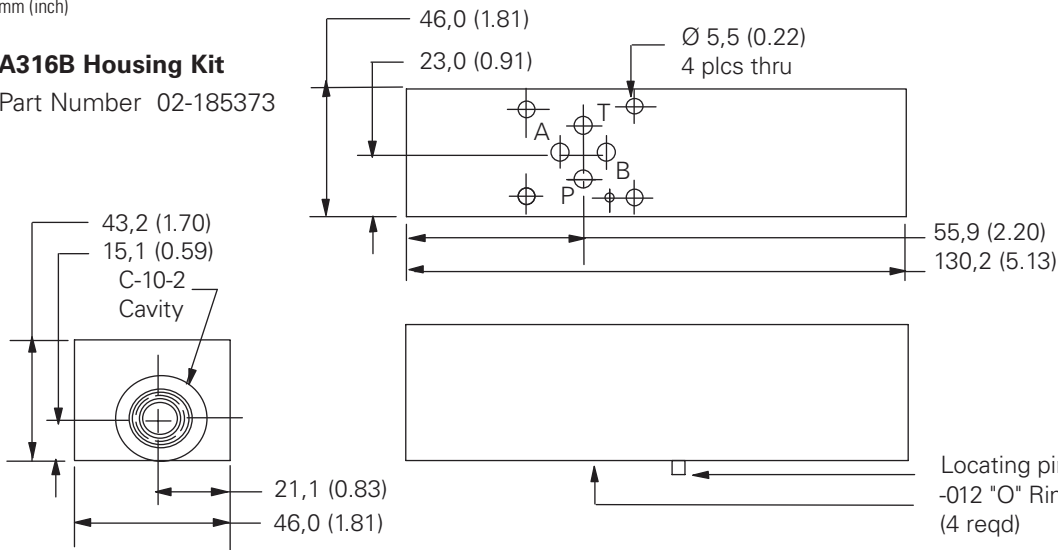

Cavity Porting

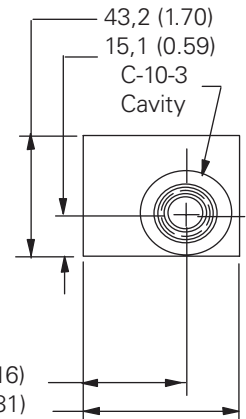
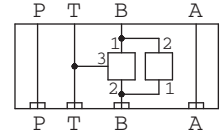

TYPICAL CARTRIDGES FUNCTION

TYPICAL CARTRIDGES	FUNCTION
PSV7-10 & CV3-10-P-0-3	Sequence valve in to B reverse free flow check

Locating pin
-012 "O" Ring
(4 reqd)

Torque cartridge in housing
48-54 Nm (35-40 ft. lbs)

A319A Housing Kit

Part Number 02-185377

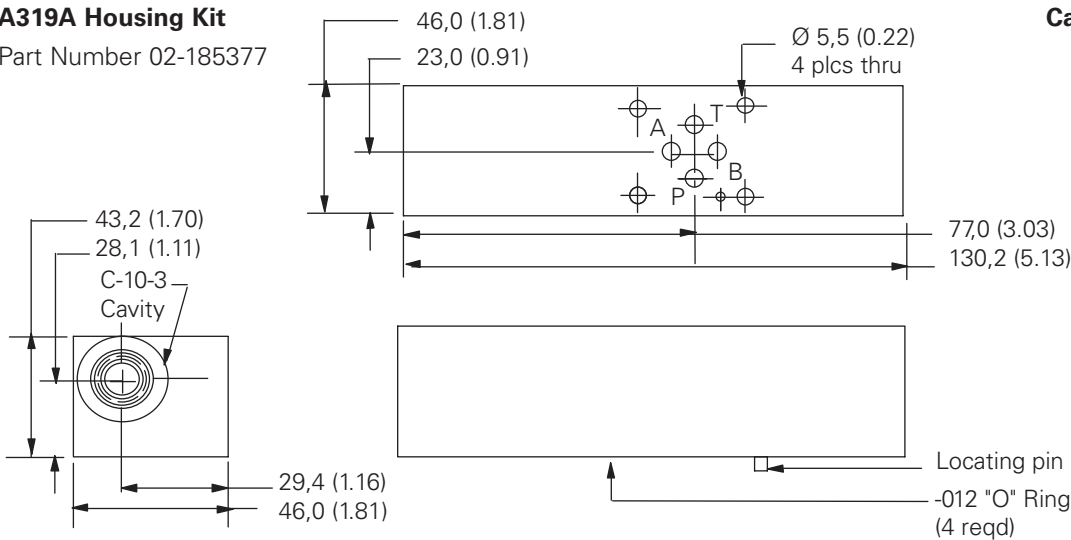

Cavity Porting

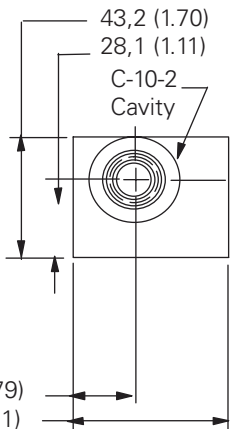
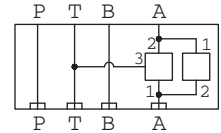

TYPICAL CARTRIDGES FUNCTION

TYPICAL CARTRIDGES	FUNCTION
PSV7-10 & CV3-10-P-0-3	Sequence valve out of A reverse free flow check

Locating pin
-012 "O" Ring
(4 reqd)

Torque cartridge in housing
48-54 Nm (35-40 ft. lbs)

Dimensions

ISO 440103/CETOP3
Housing Kits

Dimensions

mm (inch)

A319B Housing Kit

Part Number 02-185378

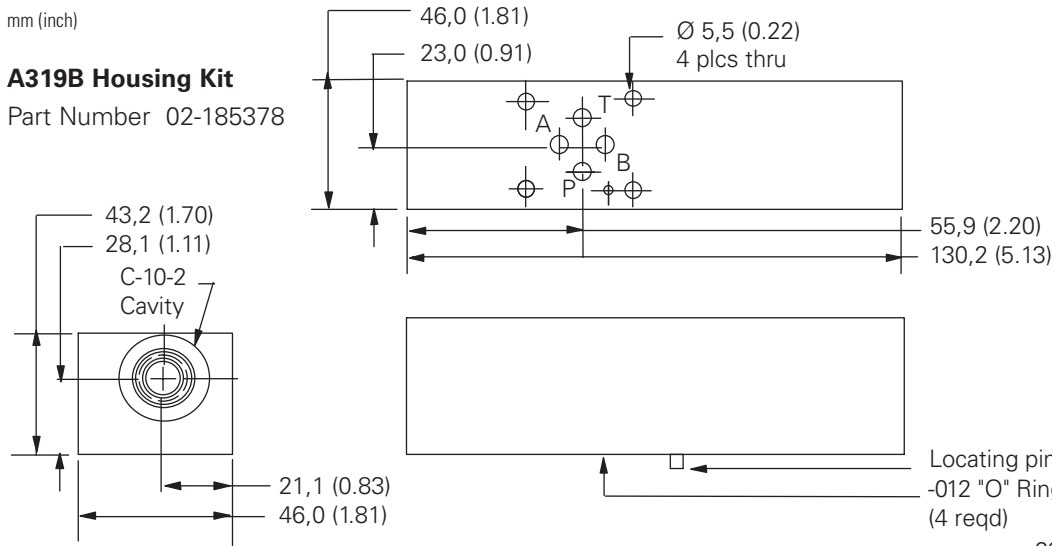

Cavity Porting

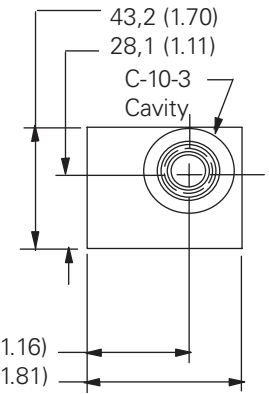
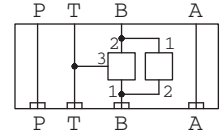

TYPICAL CARTRIDGES

FUNCTION

TYPICAL CARTRIDGES	FUNCTION
PSV7-10 & CV3-10-P-0-3	Sequence valve out of B reverse free flow check

Torque cartridge in housing
48-54 Nm (35-40 ft. lbs)

A313P Housing Kit

Part Number 02-185366

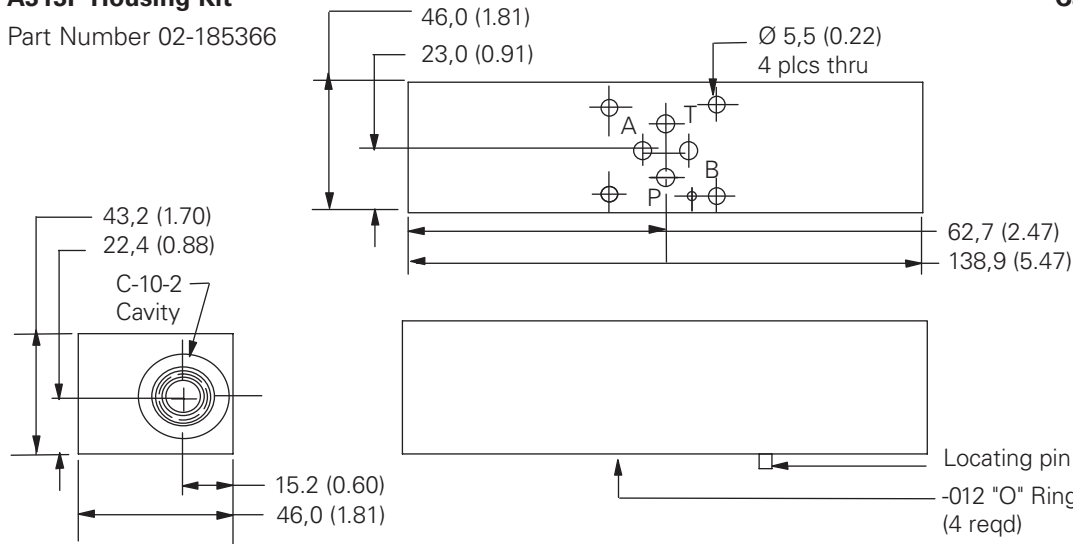

Cavity Porting

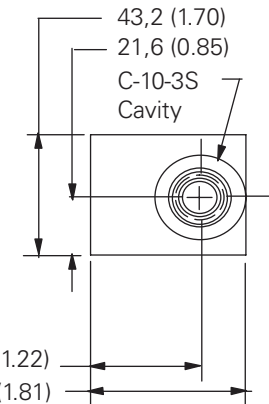
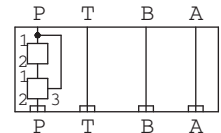

TYPICAL CARTRIDGES

FUNCTION

TYPICAL CARTRIDGES	FUNCTION
EPV-10 & DPS2-10-F-F-0-160	Proportional flow control pressure compensated on P

Torque cartridge in housing
48-54 Nm (35-40 ft. lbs)

Dimensions

ISO 440103/CETOP3
Housing Kits

Dimensions

mm (inch)

A309P Housing Kit

Part Number 02-185381

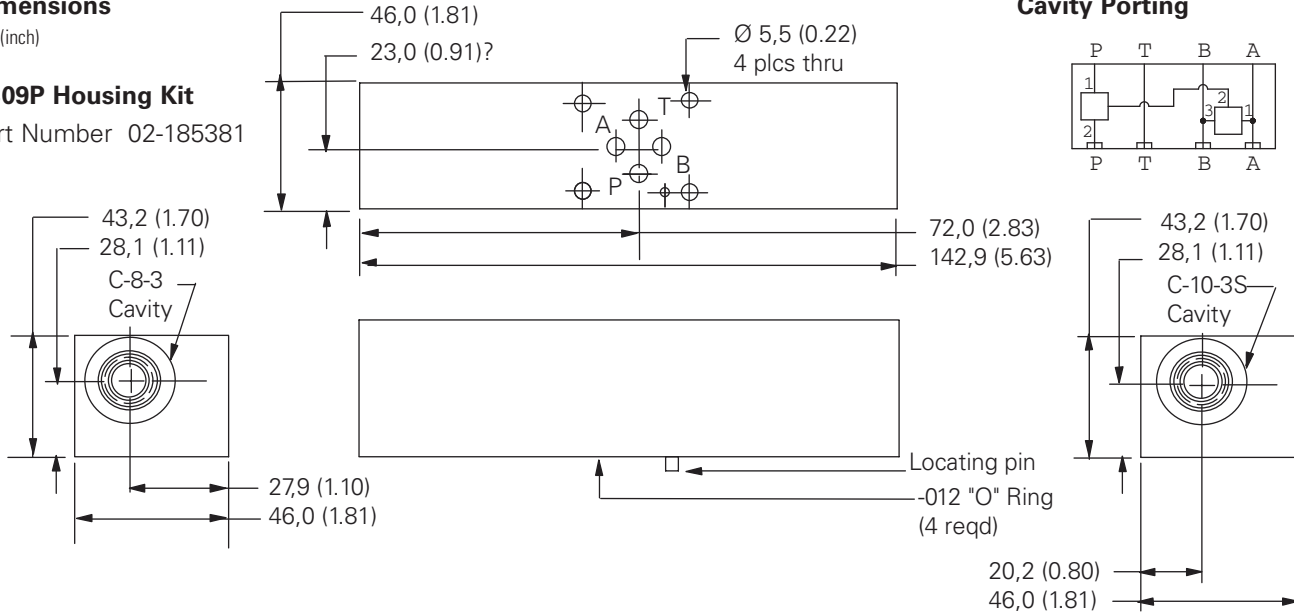

TYPICAL CARTRIDGES	FUNCTION
--------------------	----------

DPS2-10-F-F-0-* & DSV2-8-B-0	Pressure compensator restrictive on P with shuttle sense from A & B
---------------------------------	---

Torque cartridge in housing
C-8-3 34-40 Nm (25-30 ft. lbs)
C-10-3 48-54 Nm (35-40 ft. lbs)

A319P Housing Kit

Part Number 02-185382

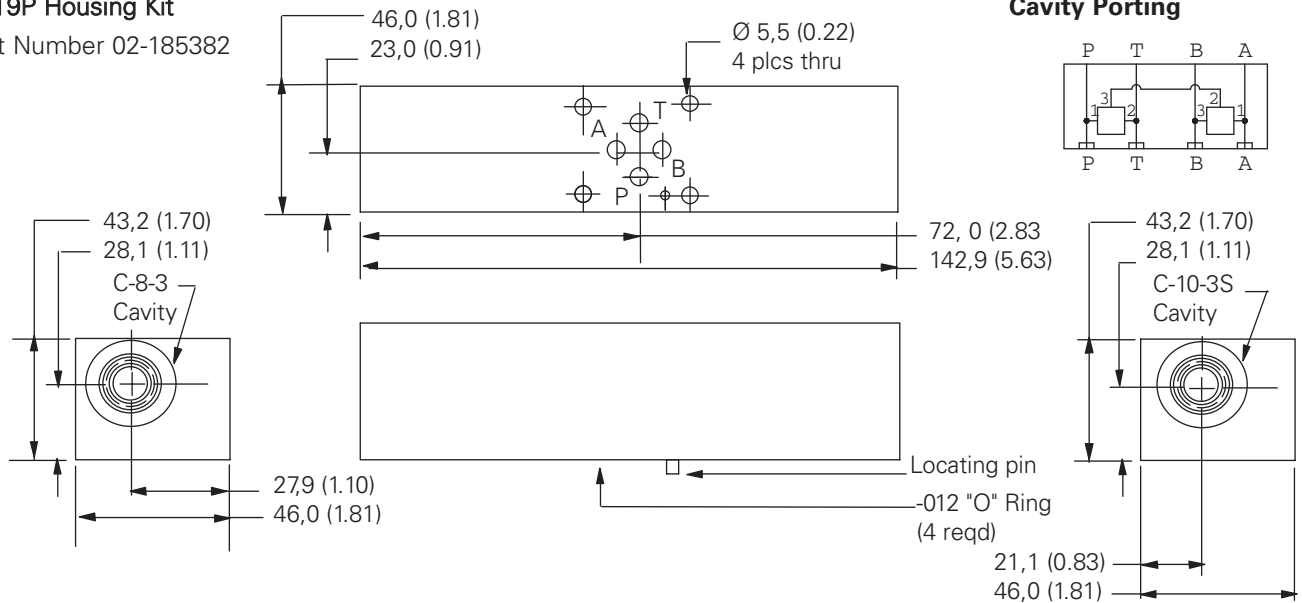

TYPICAL CARTRIDGES	FUNCTION
--------------------	----------

DPS2-10-P-F-0-* & DSV2-8-B-0	Pressure compensator bypass to T with shuttle sense from A & B
---------------------------------	--

Torque cartridge in housing
C-8-3 34-40 Nm (25-30 ft. lbs)
C-10-3 48-54 Nm (35-40 ft. lbs)