

Circuit Maker Solutions

Screw-in Cartridge Valve Packages for applications up to 210 bar (3000 psi) and 300 L/min (80 USgpm)



Section Contents

Circuit Maker Solutions

Model	Typical Application Pressure bar (psi)	Rated Flow L/mim (USgpm)	Page	
Circuit Maker Solutions - Introduction and Overview.....				K-3
Full range adjustable pressure compensated flow control package				
FC-1	210 (3000)	Up to 36 (9)	K-4	
FC-2	210 (3000)	Up to 57 (15)	K-6	
FC-3	210 (3000)	Up to 114 (30)	K-8	
FC-4	210 (3000)	Up to 190 (50)	K-10	
Full range adjustable pressure compensated flow control package with free reverse flow				
FRC-1	210 (3000)	Up to 36 (9)	K-12	
FRC-2	210 (3000)	Up to 57 (15)	K-14	
FRC-3	210 (3000)	Up to 114 (30)	K-16	
FRC-4	210 (3000)	Up to 190 (50)	K-18	
Pump control manifold for single pump circuits				
PCC1-12	210 (3000)	Up to 114 (30)	K-20	
PCC1-16	210 (3000)	Up to 228 (60)	K-22	
Pump control manifold for multiple pump circuits				
PCC2-12	210 (3000)	Up to 114 (30)	K-24	
PCC2-16	210 (3000)	Up to 228 (60)	K-26	
Fixed priority flow control with relief on priority flow port				
PFRR-8	210 (3000)	15 (4)	K-28	
PFRR-10	210 (3000)	57 (15)	K-30	
PFRR-16	210 (3000)	152 (40)	K-32	
Solenoid actuated relief valve				
SRV-8	210 (3000)	23 (6)	K-34	
SRV-10	210 (3000)	57 (15)	K-36	
SRV-12	210 (3000)	114 (30)	K-38	
SRV-16	210 (3000)	225 (60)	K-40	
SRV-20	210 (3000)	300 (80)	K-42	
Cross port relief valve				
CRV-10	210 (3000)	76 (20)	K-44	
CRV-16	210 (3000)	300 (80)	K-46	
Pressure sensitive regenerative valve package				
RGV-10	210 (3000)	57 (15)	K-48	
RGV-12	210 (3000)	114 (30)	K-50	
Pressure sensitive regenerative valve package with load locking				
RLV-10	210 (3000)	57 (15)	K-52	
RLV-12	210 (3000)	114 (30)	K-54	
Cross port relief with shuttle and solenoid vent				
SCR-1	210 (3000)	114 (30)	K-56	

Section Overview

Circuit Makers

What are circuit makers?

Circuit Maker Products are pre-engineered packages. These packages are designed with from 2 to 4 screw-in cartridge valves for generic, repetitive circuit control functions.

All of the products in this catalog are rated at 210 bar (3000 psi) and have either SAE or BSPP port options. Our selection of Circuit Maker pre-engineered packages consists of the following basic units:

- Single and multiple pump control packages
- Solenoid actuated relief valve packages
- Flow control packages
- Cross port relief packages
- Cross port relief with shuttle and solenoid vent
- Pressure sensitive regeneration packages with and without load locking

Typical Applications

Circuit Maker packages can be used in a wide variety of stationary and, on and off highway applications. The are designed to solve a multitude of repeatable, generic application requirements that are encountered in day to day hydraulic circuits. These packages are ideal solutions for specialty machine requirements and low volume options on high volume applications.

Pump control packages –

These are suitable for any single or multiple pump application where individual pump output flow does not exceed 228 l/min (60 USgpm). They are used to provide air-bleed, start-up and relief protection.

Solenoid actuated relief valve packages –

These can be used wherever remote relief or venting control is required for flows up to 300 L/min

(80 USgpm). Normally open versions lend themselves to markets where fail safe and “dead man” control are important. Normally closed versions lend themselves to markets such as machine tool, where energy savings can be obtained by selective unloading of pump flow.

Flow control packages –

These packages are used with both fixed and variable pump systems to provide constant output flow for the main or branch circuits. Packages offered provide for maintaining either:

- Cylinder or motor speed; free reverse flow for table positioning, conveyor systems and presses.
- Controlled flow for steering systems.

Cross port relief valve packages –

These packages are used with bi-directional actuators. The circuit maker provides actuator protection from overload conditions.

Pressure sensitive regeneration packages –

Pressure sensitive regeneration packages provide a means of extending a cylinder as fast as possible without additional pump flow by diverting rod end flow to the head end to accelerate the load. When the pressure in the head end reaches a predetermined level related to the load, the valve closes off and the cylinder returns to normal speed. Typical applications are for outriggers/stabilizers in mobile markets and machine tool traverse in industrial markets.

Pressure sensitive regeneration packages with load locking –

Pressure sensitive regeneration packages provide a means of extending a cylinder as fast as possible without additional pump flow by diverting rod end flow to the head end to accelerate the load. When the pressure in the head end reaches a predetermined level related to the load, the valve closes off and the cylinder returns to normal speed. The load locking feature provides stability as the system is now working with an oil column under pressure in addition to the mechanical structure.

Typically used with mobile crane and other similar vehicles to ensure stability when swinging loads. This package has an advantage over alternative systems that use solenoid actuated blocking pins. In the event of a power failure, it is still possible to lower the vehicle/load.

Features and Benefits

- Quick solutions that are ready to use
- Quick delivery at low cost
- Flexibility

Quick solutions:

Circuit Maker packages are pre-engineered packaged solutions for generic, repeatable requirements. They have specific coil voltage, coil connector, flow settings adjustment and pressure setting adjustment options that permit tailoring to application requirements.

Quick delivery/low cost:

Circuit Maker packages have already been engineered to satisfy generic, repetitive circuit needs. There are no scheduling or time related problems, or engineering charges to be recovered.

Flexibility:

Screw-in cartridge valves and housings are sold either separately or as pre-assembled packages. This permits last minute assembly of packages and local tailoring of individual valve options.

Description

Full range adjustable flow control package

Functional Symbol

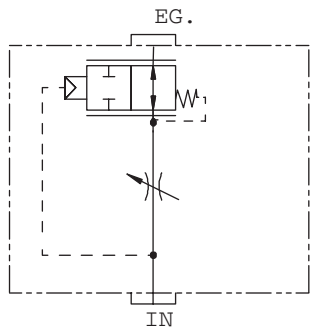

Features

- Pressure compensation
- Full flow range adjustment
- Aluminum in-line type housing
- Screw and knob adjustment options
- All components in the package are true cartridges and can be removed from the housing without disturbing the plumbing.

Application

This standard valve package is used in a circuit where flow rates must be constantly maintained, regardless of changes in upstream or downstream pressure. Also where a full range of flow adjustments is required.

RATINGS AND SPECIFICATIONS

Typical application pressure	210 bar (3000 psi)
Maximum regulated flow	Up to 36 L/min (9 USgpm)
Temperature range	-40° to 120° C (-40° to 248° F)
Fluids	All general purpose hydraulic fluids such as: MIL-H-5606, SAE 10, SAE 20, etc.

Dimensions

mm (inch)

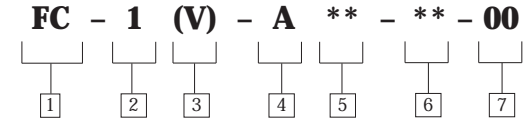
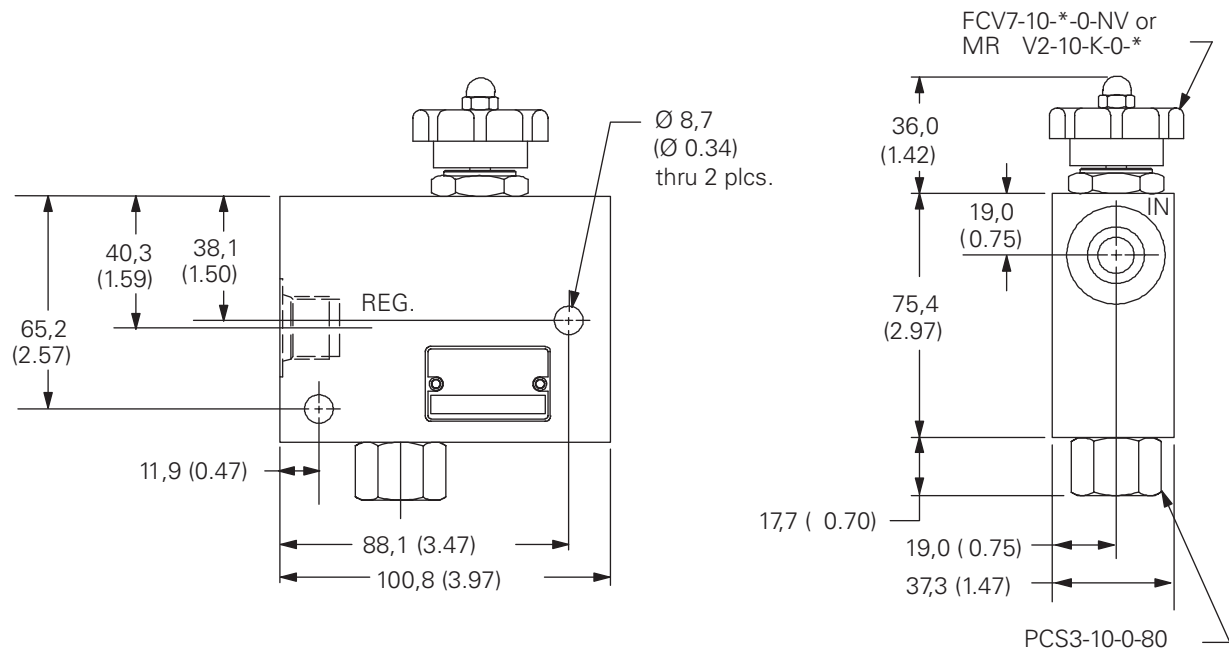

1 Function

FC - Fully adjustable pressure compensated flow control

2 Maximum Rated Flow

1 - 34 L/min (9 USgpm)

3 Seals

Blank - Buna N
V - Viton®

Viton is a registered trademark of E.I. DuPont

4 Valve Housing Material

A - Aluminum

5 Port Size

CODE	ALL PORTS	HOUSING NUMBER
4G	1/2" BSPP	02-178279
8T	SAE 8	02-178280

6 Adj. Type

Adj. Type	Flow Rate
K1 - Knob*	19 L/min (5 USgpm)
K2 - Knob	34 L/min (9 USgpm)
S1 - Screw	34 L/min (9 USgpm)
H1 - Handwheel	34 L/min (9 USgpm)

*180° rotation

7 Special Features

00 - None
(Only required if valve has special features, omitted if "00")

COMPOSITION CHART

Adjustment	Cartridge	Description	Maximum Flow L/min (USgpm)
K1 - Knob	MRV2-10-K-0-05	Flow restrictor, adjustable, semi-rotary spool	19 (5)
K2 - Knob	MRV2-10-K-0-10	Flow restrictor, adjustable, semi-rotary spool	34 (9)
S1 - Screw	FCV7-10-S-0--NV	Flow restrictor, adjustable, needle type	34 (9)
H1 - Hand Knob	FCV7-10-K-0-NV	Flow restrictor, adjustable, needle type	34 (9)
-	PCS3-10-0-80	Pressure compensator, spool type	40 (12)

Performance Characteristics

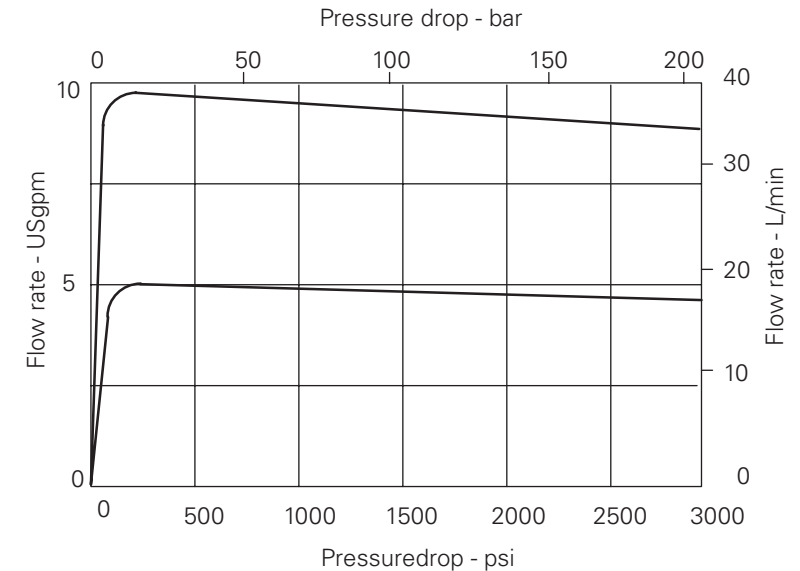

Description

Full range adjustable flow control package

Functional Symbol

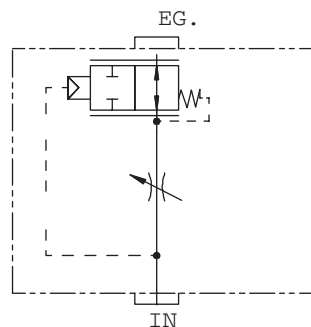

Features

- Pressure compensation
- Full flow range adjustment
- Aluminum in-line type housing
- Screw and knob adjustment options
- All components in the package are true cartridges and can be removed from the housing without disturbing the plumbing.

Application

This standard valve package is used in a circuit where flow rates must be constantly maintained, regardless of changes in upstream or downstream pressure. Also where a full range of flow adjustments is required.

RATINGS AND SPECIFICATIONS

Typical application pressure	210 bar (3000 psi)
Maximum regulated flow	Up to 57 L/min (15 USgpm)
Temperature range	-40° to 120° C (-40° to 248° F)
Fluids	All general purpose hydraulic fluids such as: MIL-H-5606, SAE 10, SAE 20, etc.

Dimensions

mm (inch)

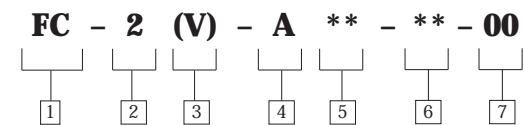
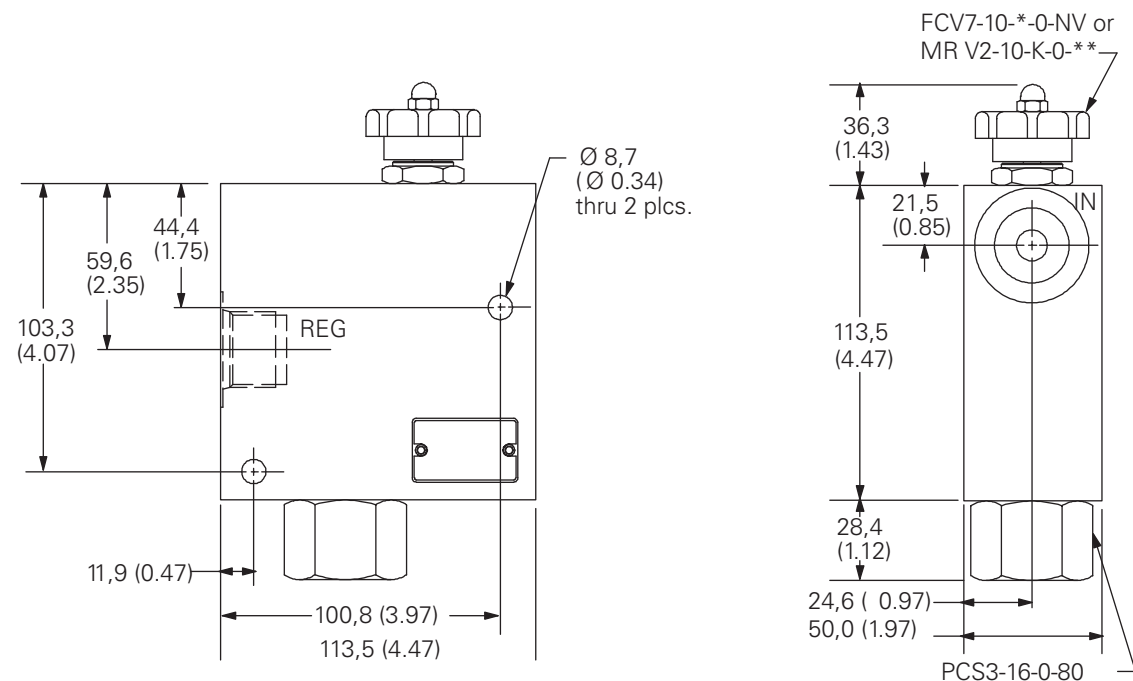

1 Function

FC - Fully adjustable pressure compensated flow control

2 Maximum Rated Flow

2 - 57 L/min (15 USgpm)

3 Seals

Blank - Buna N
V - Viton®
 Viton is a registered trademark of E.I. DuPont

4 Valve Housing Material

A - Aluminum

5 Port Size

CODE	ALL PORTS	HOUSING NUMBER
6G	3/4" BSPP	02-178281
12T	SAE 12	02-178282

6 Adj. Type

Adj. Type	Flow Rate
K1 - Knob*	38 L/min (10 USgpm)
K2 - Knob	57 L/min (15 USgpm)
S1 - Screw	57 L/min (15 USgpm)
H1 - Handwheel	57 L/min (15 USgpm)

*180° rotation

7 Special Features

00 - None
 (Only required if valve has special features, omitted if "00")

COMPOSITION CHART

Adjustment	Cartridge	Description	Maximum Flow L/min (USgpm)
K1 - Knob 180° rotation only	MRV2-10-K-0-10	Flow restrictor, adjustable, semi-rotary spool	38 (10)
K2 - Knob 180° rotation only	MRV2-10-K-0-15	Flow restrictor, adjustable, semi-rotary spool	57 (15)
S1 - Screw	FCV7-10-S-0--NV	Flow restrictor, adjustable, needle type	57 (15)
H1 - Hand Knob	FCV7-10-K-0-NV	Flow restrictor, adjustable, needle type	57 (15)
-	PCS3-16-0-80	Pressure compensator, spool type	114 (30)

Performance Characteristics

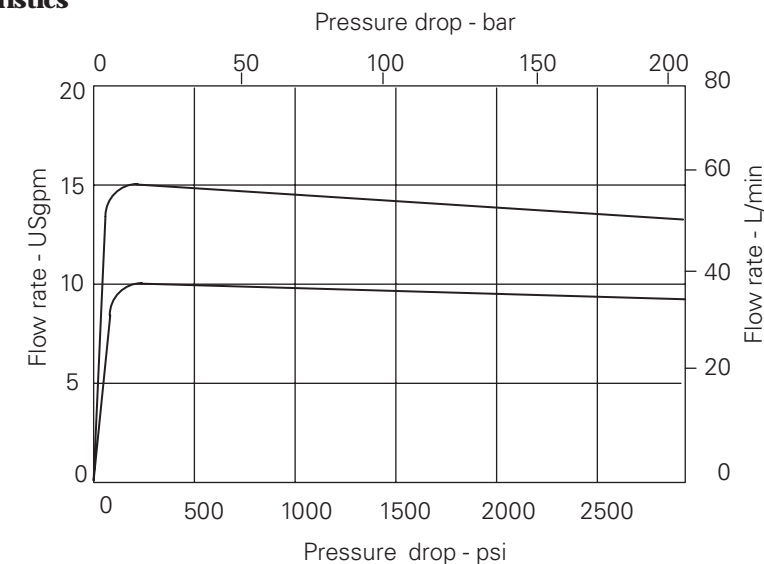

Description

Full range adjustable flow control package

Functional Symbol

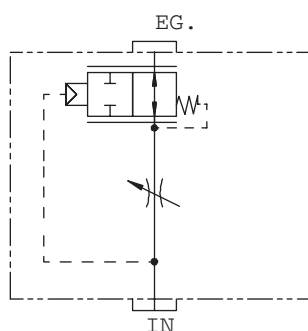

Features

- Pressure compensation
- Full flow range adjustment
- Aluminum in-line type housing
- Screw and knob adjustment options
- All components in the package are true cartridges and can be removed from the housing without disturbing the plumbing.

Application

This standard valve package is used in a circuit where flow rates must be constantly maintained, regardless of changes in upstream or downstream pressure. Also where a full range of flow adjustments is required.

RATINGS AND SPECIFICATIONS

Typical application pressure	210 bar (3000 psi)
Maximum regulated flow	Up to 114 L/min (30 USgpm)
Temperature range	-40° to 120° C (-40° to 248° F)
Fluids	All general purpose hydraulic fluids such as MIL-H-5606, SAE 10, SAE 20, etc.

Dimensions

mm (inch)

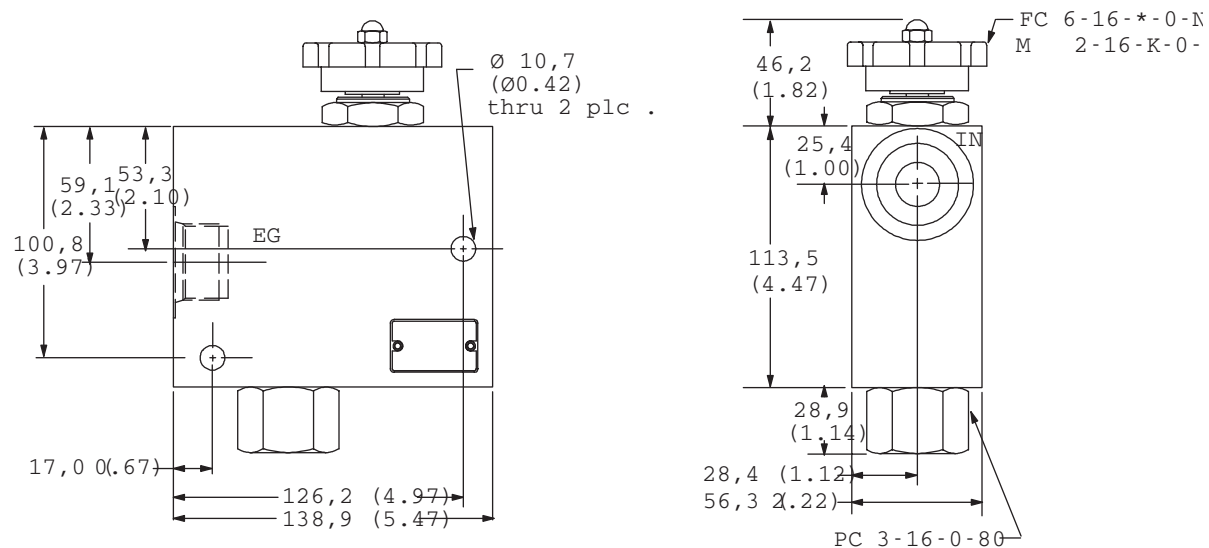

FC - 3 (V) - A ** - ** - 00

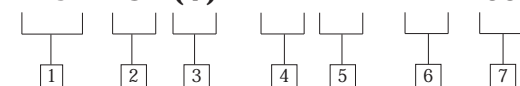

1 Function

FC - Fully adjustable pressure compensated flow control

2 Maximum Rated Flow

3 - 115 L/min (30 USgpm)

3 Seals

Blank - Buna N
V - Viton®
 Viton is a registered trademark of E.I. DuPont

4 Valve Housing Material

A - Aluminum

5 Port Size

CODE	ALL PORTS	HOUSING NUMBER
8G	1" BSPP	02-178283
16T	SAE 16	02-178284

6 Adj. Type

Adj. Type	Flow Rate
K1 - Knob*	76 L/min (20 USgpm)
K2 - Knob	114 L/min (30 USgpm)
S1 - Screw	114 L/min (30 USgpm)
H1 - Handwheel	114 L/min (30 USgpm)

*180° rotation

7 Special Features

00 - None
 (Only required if valve has special features, omitted if "00")

COMPOSITION CHART

Adjustment	Cartridge	Description	Maximum Flow L/min (USgpm)
K1 - Knob	MRV2-16-K-0-20	Flow restrictor, adjustable, semi-rotary spool	76 (20)
K2 - Knob	MRV2-16-K-0-30	Flow restrictor, adjustable, semi-rotary spool	114 (30)
S1 - Screw	FCV6-16-S-0-NV	Flow restrictor, adjustable	114 (30)
H1 - Hand Knob	FCV6-16-K-0-NV	Flow restrictor, adjustable	114 (30)
-	PCS3-16-0-80	Pressure compensator, spool type	114 (30)

Performance Characteristics

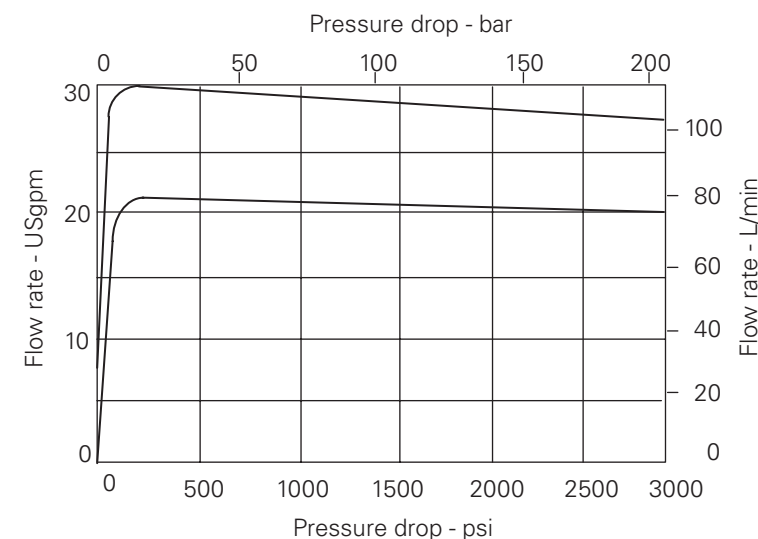

Description

Full range adjustable flow control package

Functional Symbol

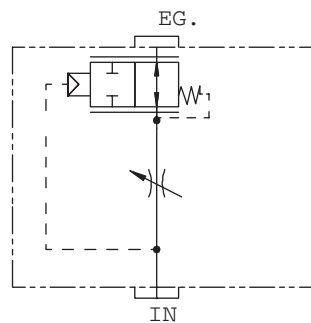

Features

- Pressure compensation
- Full flow range adjustment
- Aluminum in-line type housing
- Knob adjustment options
- All components in the package are true cartridges and can be removed from the housing without disturbing the plumbing.

Application

This standard valve package is used in a circuit where flow rates must be constantly maintained, regardless of changes in upstream or downstream pressure. Also where a full range of flow adjustments is required.

RATINGS AND SPECIFICATIONS

Typical application pressure	210 bar (3000 psi)
Maximum regulated flow	Up to 190 L/min (50 USgpm)
Temperature range	-40° to 120° C (-40° to 248° F)
Fluids	All general purpose hydraulic fluids such as: MIL-H-5606, SAE 10, SAE 20, etc.

Dimensions

mm (inch)

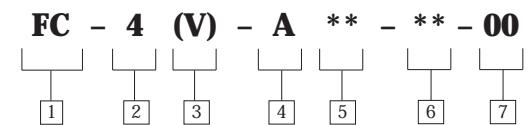
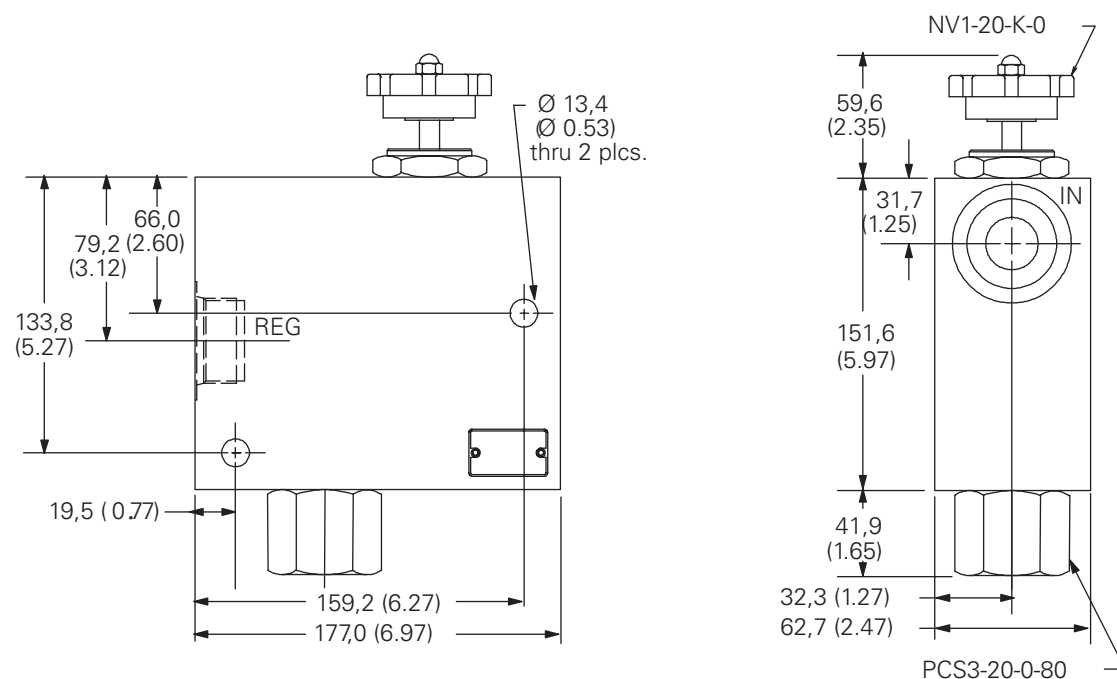

1 Function

FC - Fully adjustable pressure compensated flow control

2 Maximum Rated Flow

4 - 190 L/min (50 USgpm)

3 Seals

Blank - Buna N
V - Viton®
 Viton is a registered trademark of E.I. DuPont

4 Valve Housing Material

A - Aluminum

5 Port Size

CODE	ALL PORTS	HOUSING NUMBER
12G	1 1/4" BSPP	02-178285
20T	SAE 20	02-178286

6 Adj. Type

K1 - Knob*
 *180° rotation

Flow Rate

190 L/min (50 USgpm)

7 Special Features

00 - None
 (Only required if valve has special features, omitted if "00")

COMPOSITION CHART

Adjustment	Cartridge	Description	Maximum Flow L/min (USgpm)
K1 - Knob	NV1-20-K-0	Needle Valve	190 (50)
-	PCS3-20-0-80	Pressure compensator, spool type	200 (53)

Performance Characteristics

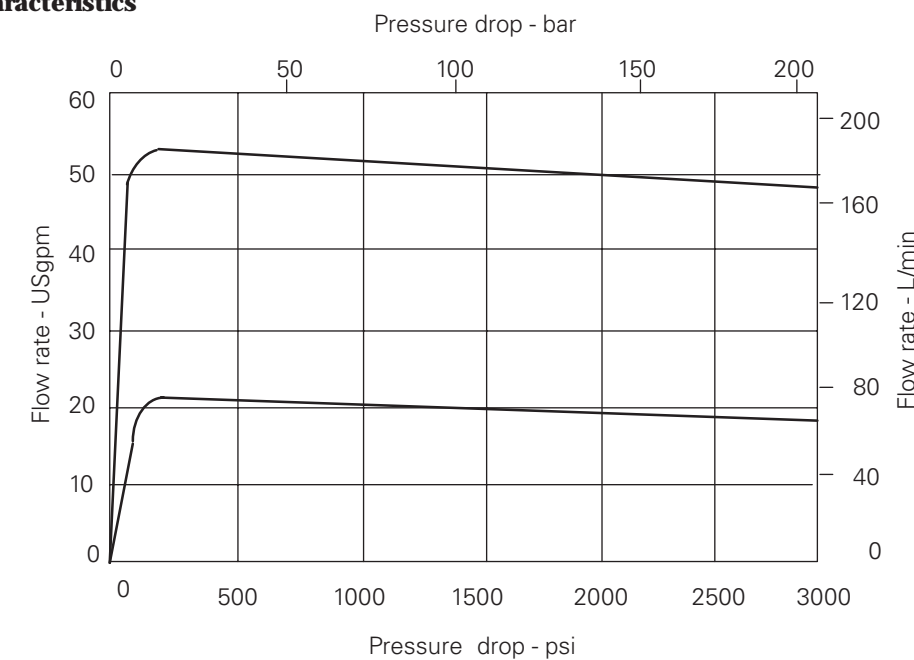

Full range adjustable flow control package with free reverse flow

Description

Full range adjustable flow control package with free reverse flow

Functional Symbol

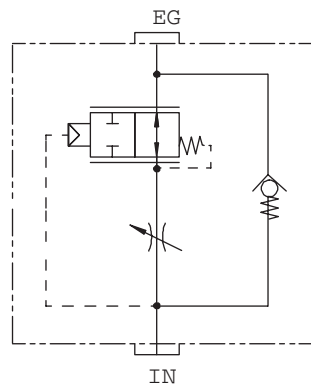

Features

- Pressure compensation
- Full flow range adjustment
- Free reverse flow
- Aluminum in-line housing
- Screw and knob adjustment options
- All components in the package are true cartridges and can be removed from the housing without disturbing the plumbing.

Application

This standard valve package is used in a hydraulic circuit where flow rates must be constantly maintained, regardless of changes in upstream or downstream pressure. Also where a full range of flow adjustments is required. It also provides free reverse flow.

RATINGS AND SPECIFICATIONS

Typical application pressure	210 bar (3000 psi)
Maximum regulated flow	Up to 36 L/min (9 USgpm)
Temperature range	-40° to 120° C (-40° to 248° F)
Fluids	All general purpose hydraulic fluids such as: MIL-H-5606, SAE 10, SAE 20, etc.

Dimensions

mm (inch)

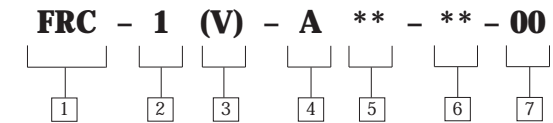
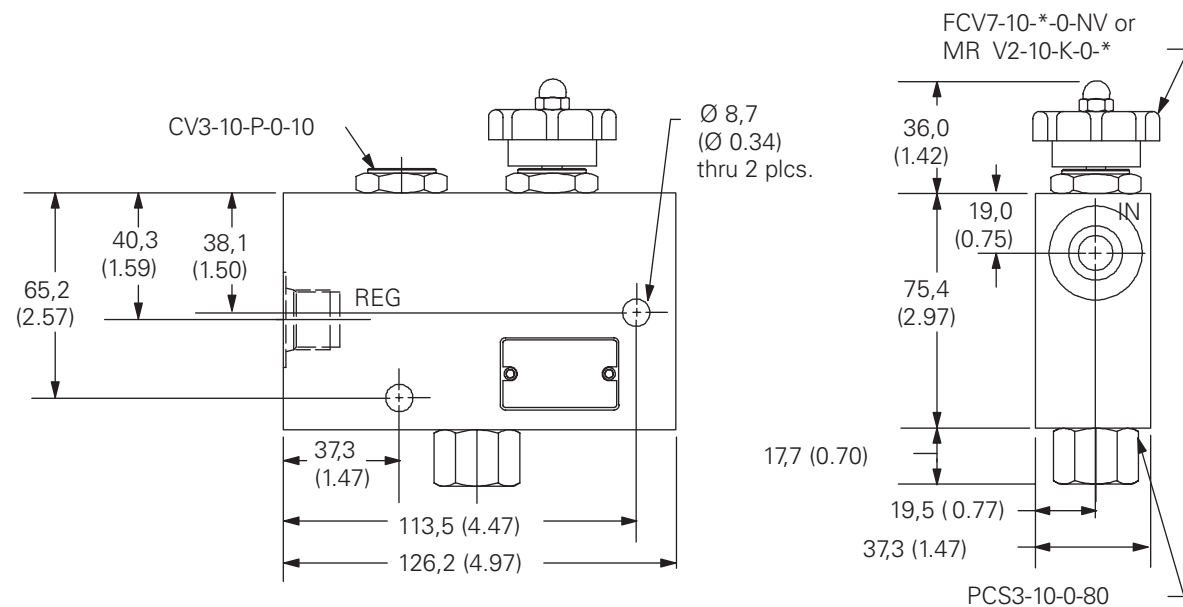

1 Function

FRC - Fully adjustable pressure compensated flow control with reverse flow check

2 Maximum Rated Flow

1 - 34 L/min (9 USgpm)

3 Seals

Blank - Buna N
V - Viton®
 Viton is a registered trademark of E.I. DuPont

4 Valve Housing Material

A - Aluminum

5 Port Size

CODE	ALL PORTS	HOUSING NUMBER
4G	1/2" BSPP	02-178287
8T	SAE 8	02-178288

6 Adj. Type

Adj. Type	Flow Rate
K1 - Knob*	19 L/min (5 USgpm)
K2 - Knob	34 L/min (9 USgpm)
S1 - Screw	34 L/min (9 USgpm)
H1 - Handwheel	34 L/min (9 USgpm)

*180° rotation

7 Special Features

00 - None
 (Only required if valve has special features, omitted if "00")

COMPOSITION CHART

Adjustment	Cartridge	Description	Maximum Flow L/min (USgpm)
K1 - Knob	MRV2-10-K-0-05	Flow restrictor, adjustable, semi-rotary spool	19 (5)
K2 - Knob	MRV2-10-K-0-10	Flow restrictor, adjustable, semi-rotary spool	34 (9)
S1 - Screw	FCV7-10-S-0--NV	Flow restrictor, adjustable, needle type	34 (9)
H1 - Hand Knob	FCV7-10-K-0-NV	Flow restrictor, adjustable, needle type	34 (9)
-	CV3-10-P-0-10	Check valve	76 (20)
-	PCS3-10-0-80	Pressure compensator, spool type	40 (12)

Performance Characteristics

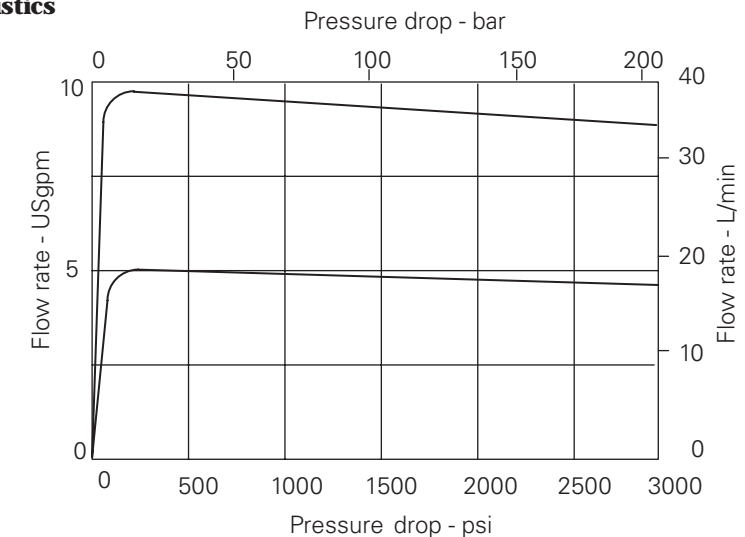

Full range adjustable flow control package with free reverse flow

Description

Full range adjustable flow control package with free reverse flow

Functional Symbol

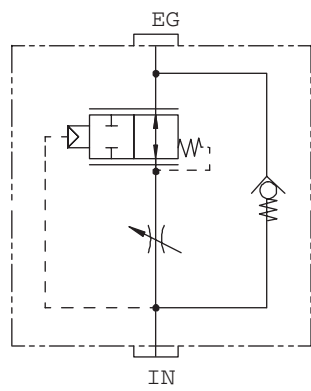

Features

- Pressure compensation
- Full flow range adjustment
- Free reverse flow
- Aluminum in-line housing
- Screw and knob adjustment options
- All components in the package are true cartridges and can be removed from the housing without disturbing the plumbing.

Application

This standard valve package is used in a hydraulic circuit where flow rates must be constantly maintained, regardless of changes in upstream or downstream pressure. Also where a full range of flow adjustments is required. It also provides free reverse flow.

RATINGS AND SPECIFICATIONS

Typical application pressure	210 bar (3000 psi)
Maximum regulated flow	Up to 57 L/min (15 USgpm)
Temperature range	-40° to 120° C (-40° to 248° F)
Fluids	All general purpose hydraulic fluids such as: MIL-H-5606, SAE 10, SAE 20, etc.

Dimensions

mm (inch)

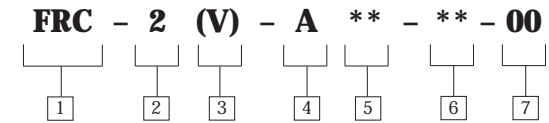
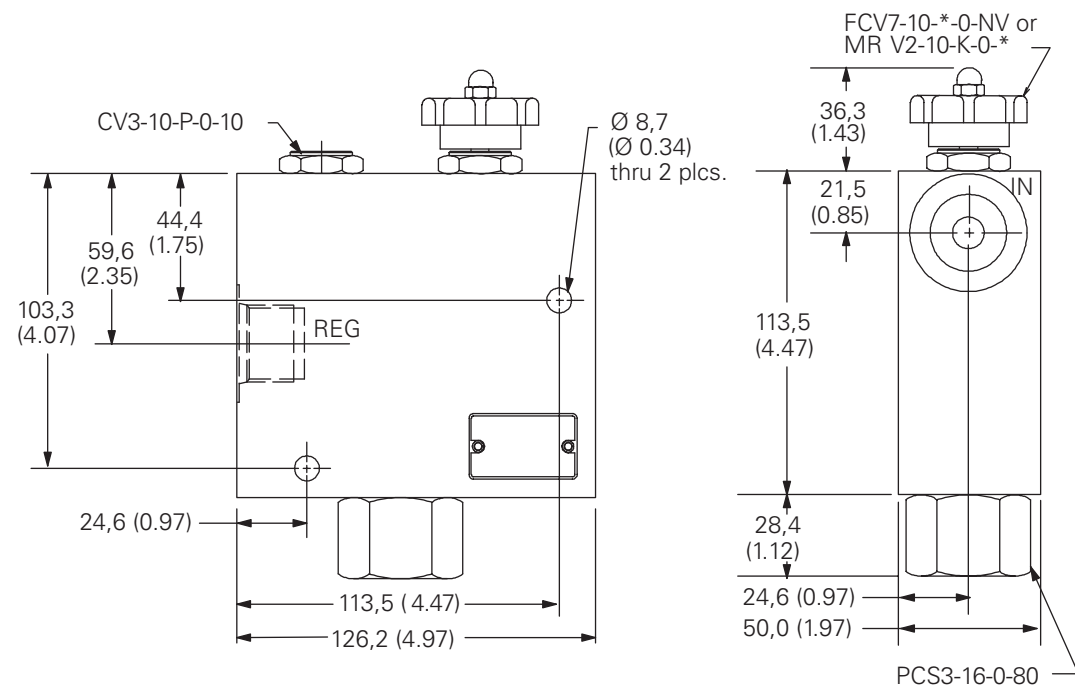

1 Function

FRC - Fully adjustable pressure compensated flow control with reverse flow check

2 Maximum Rated Flow

2 - 57 L/min (15 USgpm)

3 Seals

Blank - Buna N
V - Viton®
 Viton is a registered trademark of E.I. DuPont

4 Valve Housing Material

A - Aluminum

5 Port Size

CODE	ALL PORTS	HOUSING NUMBER
6G	3/4" BSPP	02-178289
12T	SAE 12	02-178290

6 Adj. Type

Adj. Type	Flow Rate
K1 - Knob*	38 L/min (10 USgpm)
K2 - Knob	57 L/min (15 USgpm)
S1 - Screw	57 L/min (15 USgpm)
H1 - Handwheel	57 L/min (15 USgpm)

*180° rotation

7 Special Features

00 - None
 (Only required if valve has special features, omitted if "00")

COMPOSITION CHART

Adjustment	Cartridge	Description	Maximum Flow L/min (USgpm)
K1 - Knob	MRV2-10-K-0-10	Flow restrictor, adjustable, semi-rotary spool	38 (10)
K2 - Knob	MRV2-10-K-0-15	Flow restrictor, adjustable, semi-rotary spool	57 (15)
S1 - Screw	FCV7-10-S-0-NV	Flow restrictor, adjustable, needle type	57 (15)
H1 - Hand Knob	FCV7-10-K-0-NV	Flow restrictor, adjustable, needle type	57 (15)
-	CV3-10-P-0-10	Check valve	76 (20)
-	PCS3-16-0-80	Pressure compensator, spool type	114 (30)

Performance Characteristics

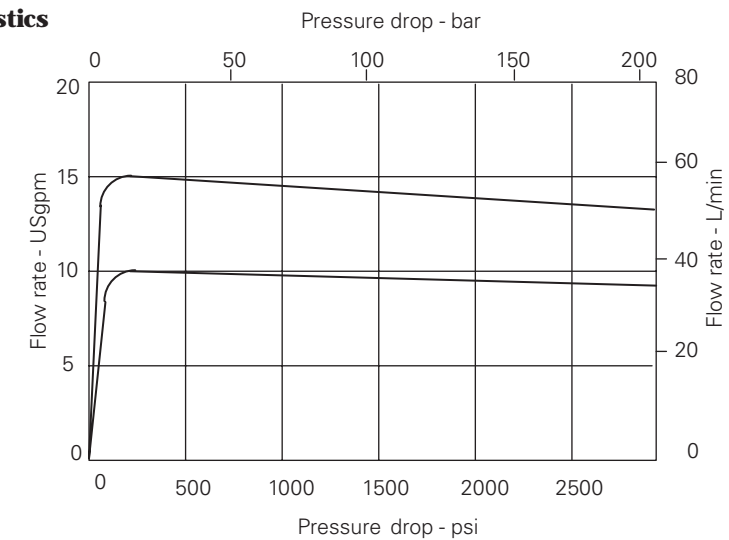

Full range adjustable flow control package with free reverse flow

Description

Full range adjustable flow control package with free reverse flow

Functional Symbol

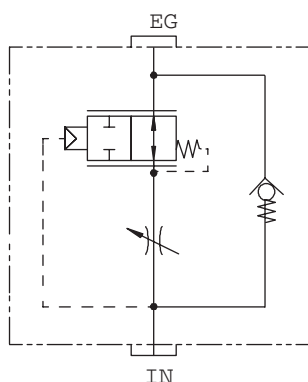

Features

- Pressure compensation
- Full flow range adjustment
- Free reverse flow
- Aluminum in-line housing
- Screw and knob adjustment options
- All components in the package are true cartridges and can be removed from the housing without disturbing the plumbing.

Application

This standard valve package is used in a hydraulic circuit where flow rates must be constantly maintained, regardless of changes in upstream or downstream pressure. Also where a full range of flow adjustments is required. It also provides free reverse flow.

RATINGS AND SPECIFICATIONS

Typical application pressure	210 bar (3000 psi)
Maximum regulated flow	Up to 114 L/min (30 USgpm)
Temperature range	-40° to 120° C (-40° to 248° F)
Fluids	All general purpose hydraulic fluids such as: MIL-H-5606, SAE 10, SAE 20, etc.

Dimensions

mm (inch)

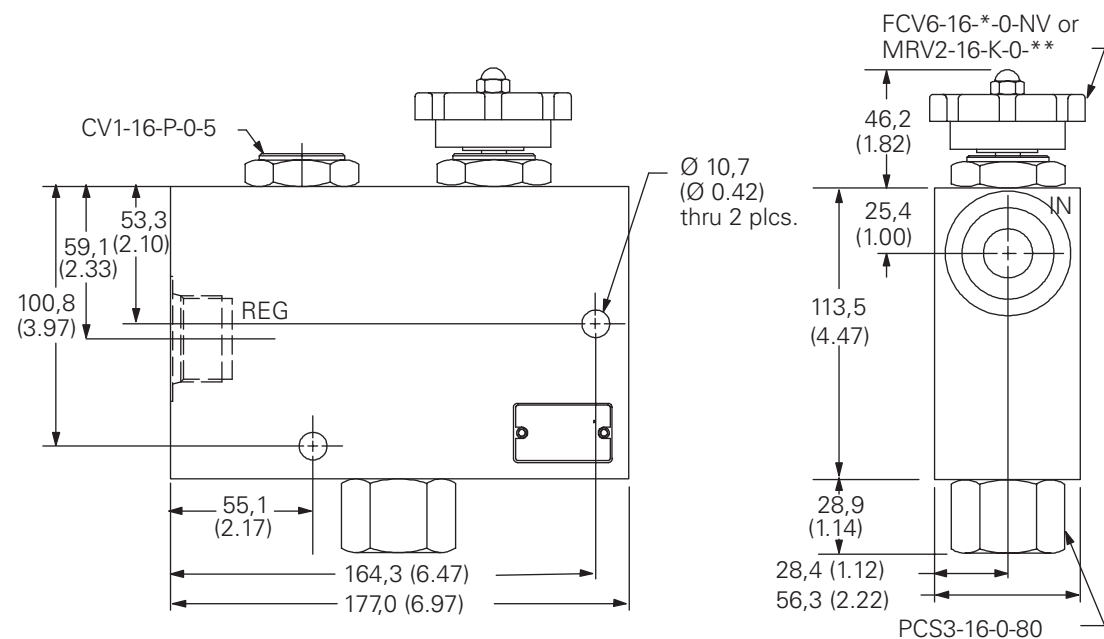

FRC - 3 (V) - A ** - ** - 00

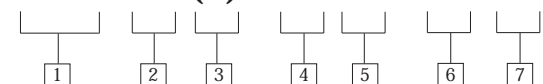

1 Function

FRC - Fully adjustable pressure compensated flow control with reverse flow check

2 Maximum Rated Flow

3 - 115 L/min (30 USgpm)

3 Seals

Blank - Buna N
V - Viton®
 Viton is a registered trademark of E.I. DuPont

4 Valve Housing Material

A - Aluminum

5 Port Size

CODE	ALL PORTS	HOUSING NUMBER
8G	1" BSPP	02-178291
16T	SAE 16	02-178292

6 Adj. Type

Adj. Type	Flow Rate
K1 - Knob*	76 L/min (20 USgpm)
K2 - Knob	114 L/min (30 USgpm)
S1 - Screw	114 L/min (30 USgpm)
H1 - Handwheel	114 L/min (30 USgpm)

*180° rotation

7 Special Features

00 - None
 (Only required if valve has special features, omitted if "00")

COMPOSITION CHART

Adjustment	Cartridge	Description	Maximum Flow L/min (USgpm)
K1 - Knob	MRV2-16-K-0-20	Flow restrictor, adjustable, semi-rotary spool	76 (20)
K2 - Knob	MRV2-16-K-0-30	Flow restrictor, adjustable, semi-rotary spool	114 (30)
S1 - Screw	FCV6-16-S-0-NV	Flow restrictor, adjustable, needle type	114 (30)
H1 - Hand Knob	FCV6-16-K-0-NV	Flow restrictor, adjustable, needle type	114 (30)
-	CV1-16-P-0-5	Check valve	115 (40)
-	PCS3-16-0-80	Pressure compensator, spool type	114 (30)

Performance Characteristics

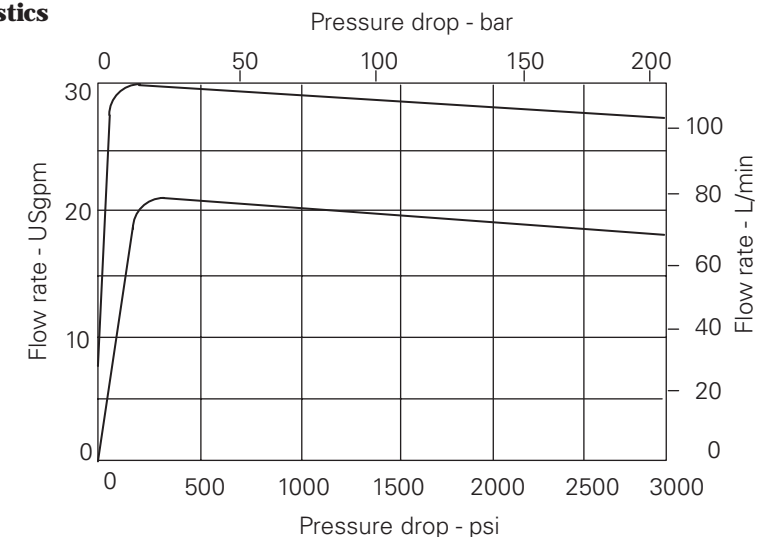

Full range adjustable flow control package with free reverse flow

Description

Full range adjustable flow control package with free reverse flow

Functional Symbol

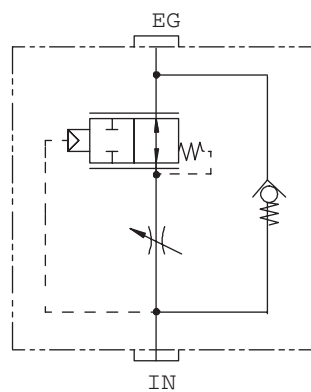

Features

- Pressure compensation
- Full flow range adjustment
- Free reverse flow
- Aluminum in-line housing
- Screw and knob adjustment options
- All components in the package are true cartridges and can be removed from the housing without disturbing the plumbing.

Application

This standard valve package is used in a hydraulic circuit where flow rates must be constantly maintained, regardless of changes in upstream or downstream pressure. Also where a full range of flow adjustments is required. It also provides free reverse flow.

RATINGS AND SPECIFICATIONS

Typical application pressure	210 bar (3000 psi)
Maximum regulated flow	Up to 190 L/min (50 USgpm)
Temperature range	-40° to 120° C (-40° to 248° F)
Fluids	All general purpose hydraulic fluids such as: MIL-H-5606, SAE 10, SAE 20, etc.

Dimensions

mm (inch)

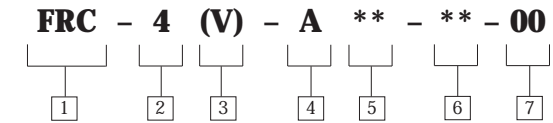
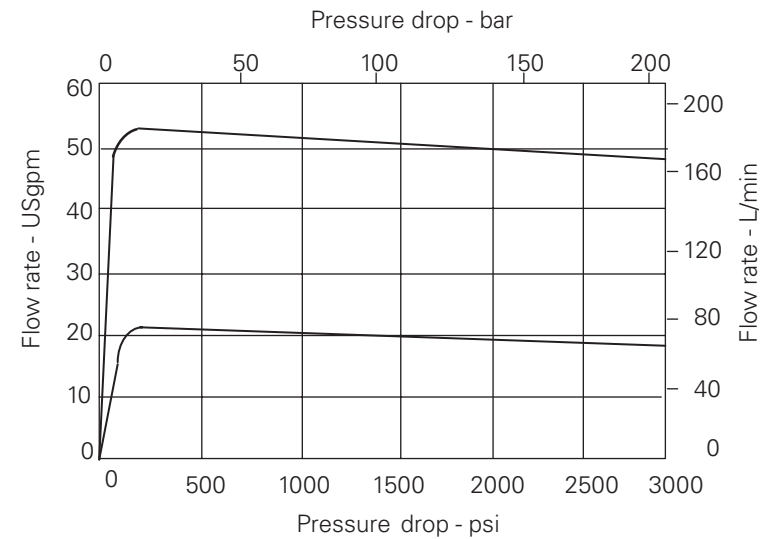

1 Function

FRC - Fully adjustable pressure compensated flow control with reverse flow check

2 Maximum Rated Flow

4 - 190 L/min (30 USgpm)

3 Seals

Blank - Buna N
V - Viton®
 Viton is a registered trademark of E.I. DuPont

4 Valve Housing Material

A - Aluminum

5 Port Size

CODE	ALL PORTS	HOUSING NUMBER
12G	1 1/4" BSPP	02-178293
20T	SAE 20	02-178294

6 Adj. Type

K1 - Knob*
 *180° rotation

Flow Rate

190 L/min (50 USgpm)

7 Special Features

00 - None
 (Only required if valve has special features, omitted if "00")

COMPOSITION CHART

Adjustment	Cartridge	Description	Maximum Flow L/min (USgpm)
K1 - Knob	NV1-20-K-0	Needle valve	190 (50)
-	CV2-20-P-0-5	Check valve	220 (60)
-	PCS3-20-0-80	Pressure compensator, spool type	200 (53)

Performance Characteristics

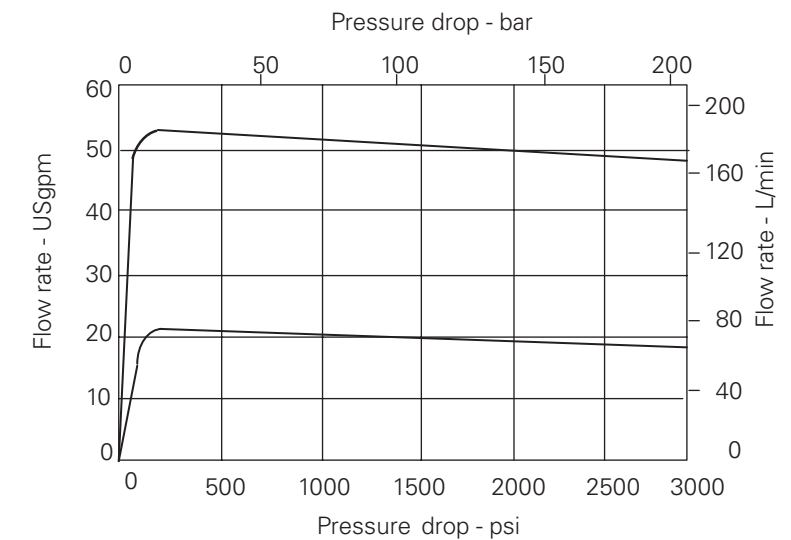

Description

Pump control manifold for single pump circuits

Functional Symbol

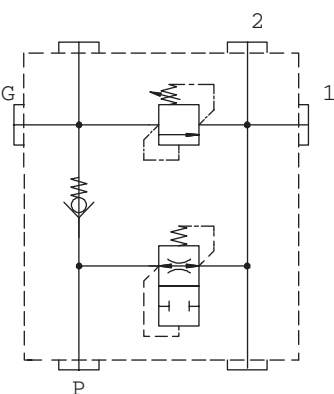

Features

- Multiple tank ports for mounting convenience
- Direct reservoir mounting capability by using "T" port. Both "T" port and mounting holes have o'ring seals
- Aluminum in-line type housing
- Tamper proof and adjustable relief options
- Gauge port
- All components in the package are true cartridges and can be removed from the housing without disturbing the plumbing.

Application

This standard valve package is used for air-bleed and start-up in single pump power units. It also provides main system relief protection.

RATINGS AND SPECIFICATIONS

Typical application pressure range	5 - 210 bar (75 - 3000 psi)
Maximum regulated flow	up to 114 L/min (30 USgpm)
Temperature range	-40° to 120° C (-40° to 248° F)
Reset pressure	90% of crack pressure
Fluids	All general purpose hydraulic fluids such as: MIL-H-5606, SAE 10, SAE 20, etc.

Dimensions

mm (inch)

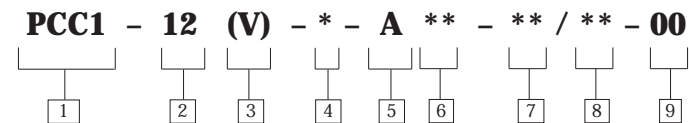
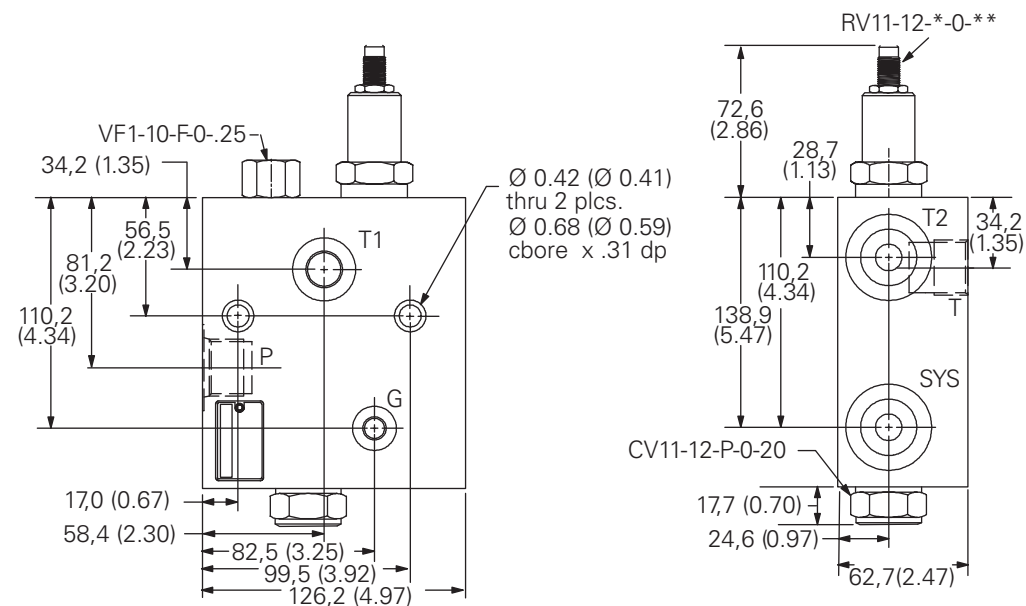

1 Function PCC - Pump control for single pump circuits	4 Relief Control C - Cap K - Knob S - Screw	7 Pressure Range 15 - 5 - 100 bar (75-1500psi) 30 - 10 - 210 bar (150-3000psi)	9 Special Features 00 - None (Only required if valve has special features, omitted if "00")
2 Size 12 - 12 size	5 Valve Housing Material A - Aluminum	8 Pressure setting - user requested in 50 PSI steps example 10 - 1000psi 10.5 - 1050psi	
3 Seals Blank - Buna N V - Viton® <small>Viton is a registered trademark of E.I. DuPont</small>	6 Port Size		

CODE	P, SYS, T2	T1	GAUGE
6G	3/4" BSPP	1/2" BSPP	1/4" BSPP
12T	SAE 12	SAE 8	SAE 4

COMPOSITION CHART

Cartridge	Description	Maximum Flow	Quantity
VF1-10-F-0-.25	Velocity fuse	23 L/min (6 USgpm)	1
CV11-12-P-0-20	Check valve	113 L/min (30 USgpm)	1
RV11-12-*0-**	Relief valve	113 L/min (30 USgpm)	1

Pressure Drop Curve

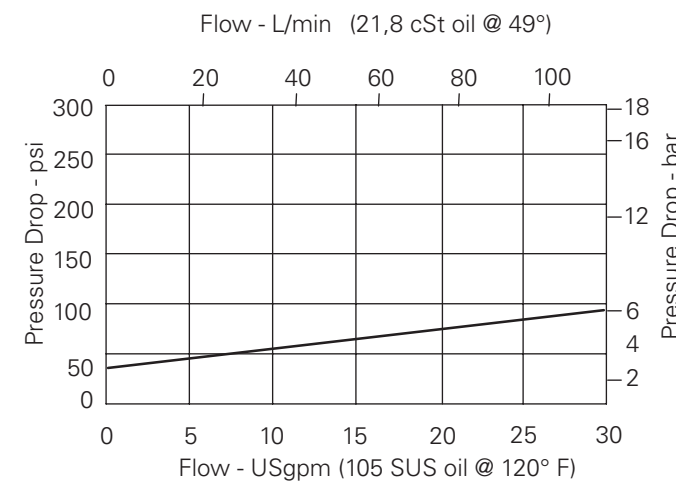

Pressure Override Curves

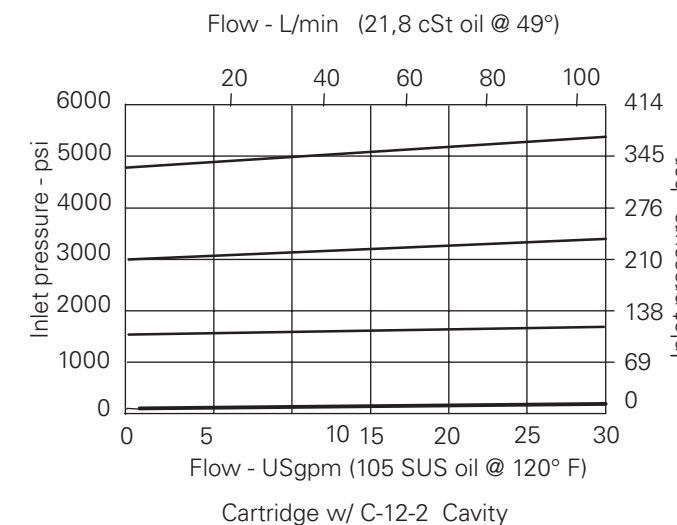

Description

Pump control manifold for single pump circuits

Functional Symbol

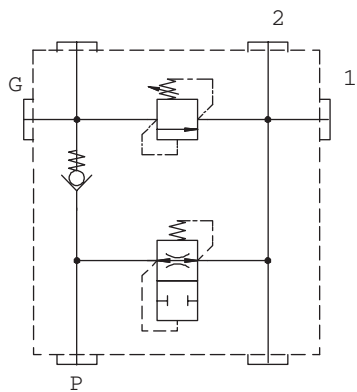

Features

- Multiple tank ports for mounting convenience
- Direct reservoir mounting capability by using "T" port. Both "T" port and mounting holes have o'ring seals
- Aluminum in-line type housing
- Tamper proof and adjustable relief options
- Gauge port
- All components in the package are true cartridges and can be removed from the housing without disturbing the plumbing.

Application

This standard valve package is used for air-bleed and start-up in single pump power units. It also provides main system relief protection.

RATINGS AND SPECIFICATIONS

Typical application pressure range	10 - 210 bar (150 - 3000 psi)
Maximum regulated flow	up to 228 L/min (60 USgpm)
Temperature range	-40° to 120° C (-40° to 248° F)
Reset pressure	90% of crack pressure
Fluids	All general purpose hydraulic fluids such as: MIL-H-5606, SAE 10, SAE 20, etc.

Dimensions

mm (inch)

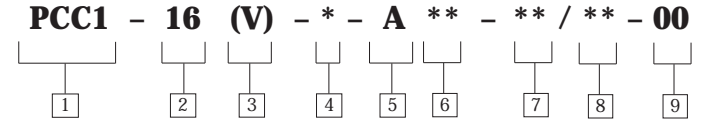
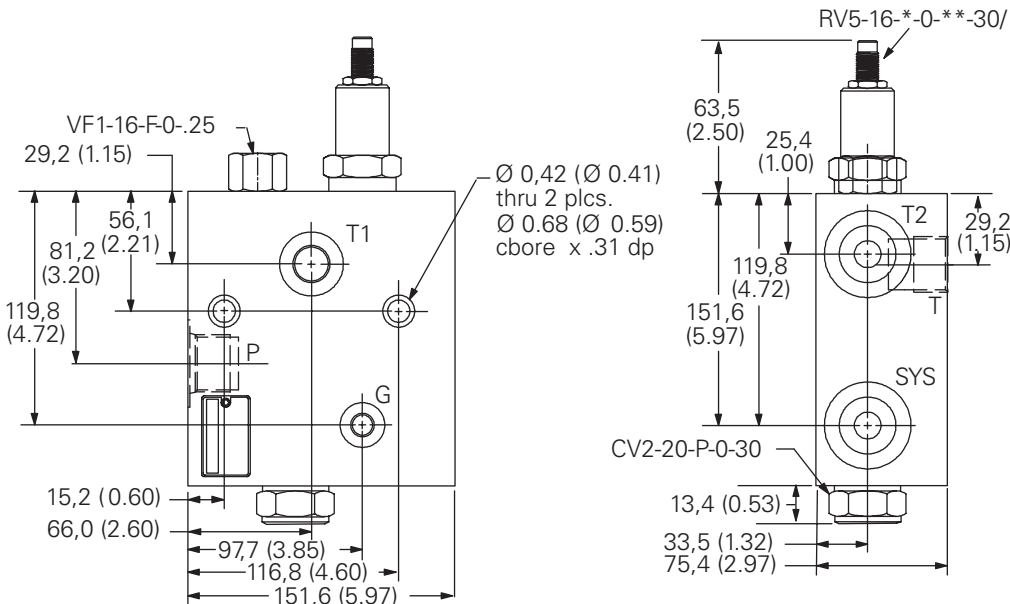

1 Function

PCC1 - Pump control for single pump circuits

2 Size

16 - 16 size

3 Seals

Blank - Buna N
V - Viton®
 Viton is a registered trademark of E.I. DuPont

4 Relief Control

C - Cap
K - Knob
S - Screw

5 Valve Housing Material

A - Aluminum

7 Pressure Range

30 - 10 - 210 bar (150-3000psi)

8 Pressure setting - user requested in 50 PSI steps

example
10 - 1000psi
10.5 - 1050psi

9 Special Features

00 - None
 (Only required if valve has special features, omitted if "00")

6 Port Siz

CODE	P, SYS, T2	T1	GAUGE
8G	1" BSPP	3/4" BSPP	1/4" BSPP
16T	SAE 16	SAE 8	SAE 4

COMPOSITION CHART

Cartridge	Description	Maximum Flow	Quantity
VF1-10-F-0-.25	Velocity fuse	23 L/min (6 USgpm)	1
CV2-20-P-0-30	Check valve	228 L/min (60 USgpm)	1
RV5-16-*-*-*30	Relief valve	303 L/min (80 USgpm)	1

Pressure Drop Curve

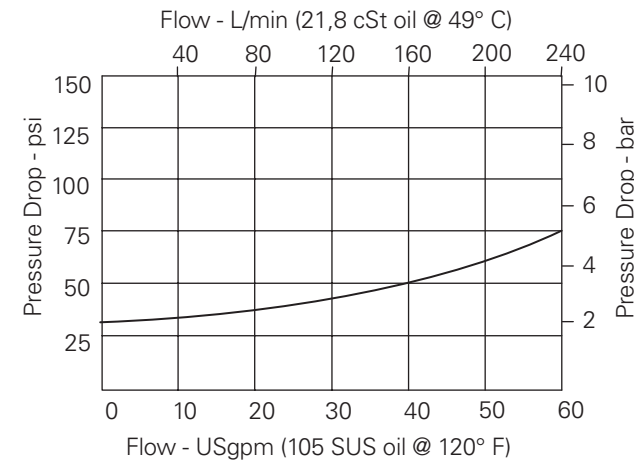

Pressure Override Curves

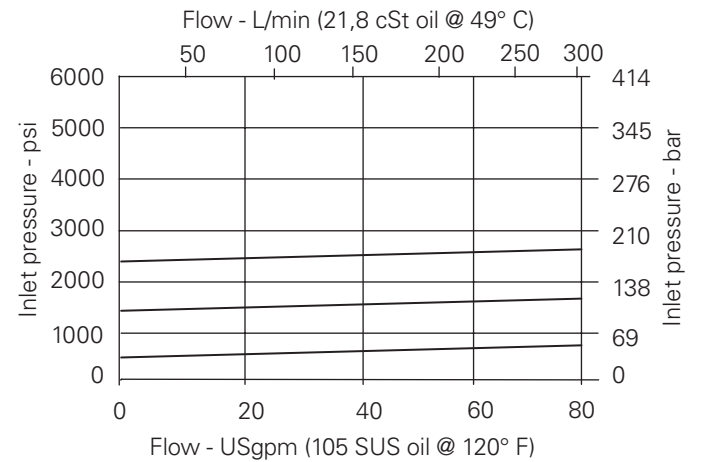

Description

Pump control manifold for multiple pump circuits

Functional Symbol

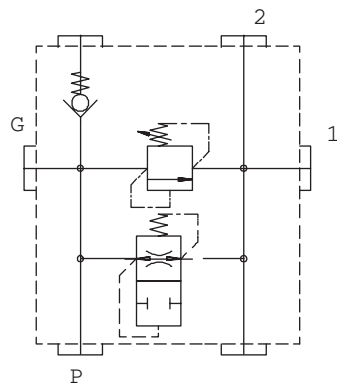

Features

- Individual relief pressure setting for each pump in the system
- Multiple tank ports for mounting convenience
- Direct reservoir mounting capability by using "T" port. Both "T" port and mounting holes have o'ring seals mounting surface.
- Aluminum in-line type housing
- Tamper proof and adjustable relief options
- Gauge port
- All components in the package are true cartridges and can be removed from the housing without disturbing the plumbing.

Application

This standard valve package is used to provide air-bleed, start-up and relief protection for each pump in multiple pump circuits. The check valve position in the circuit isolates the other pumps from the valve assembly.

RATINGS AND SPECIFICATIONS

Typical application pressure range	5 - 210 bar (75 - 3000 psi)
Maximum regulation flow	up to 114 L/min (30 USgpm)
Temperature range	-40° to 120° C (-40° to 248° F)
Reseat pressure	90% of crack pressure
Fluids	All general purpose hydraulic fluids such as: MIL-H-5606, SAE 10, SAE 20, etc.

Dimensions

mm (inch)

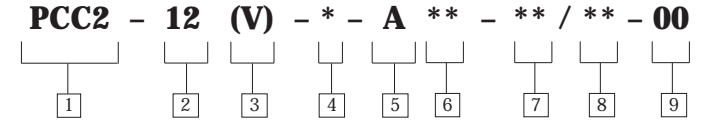
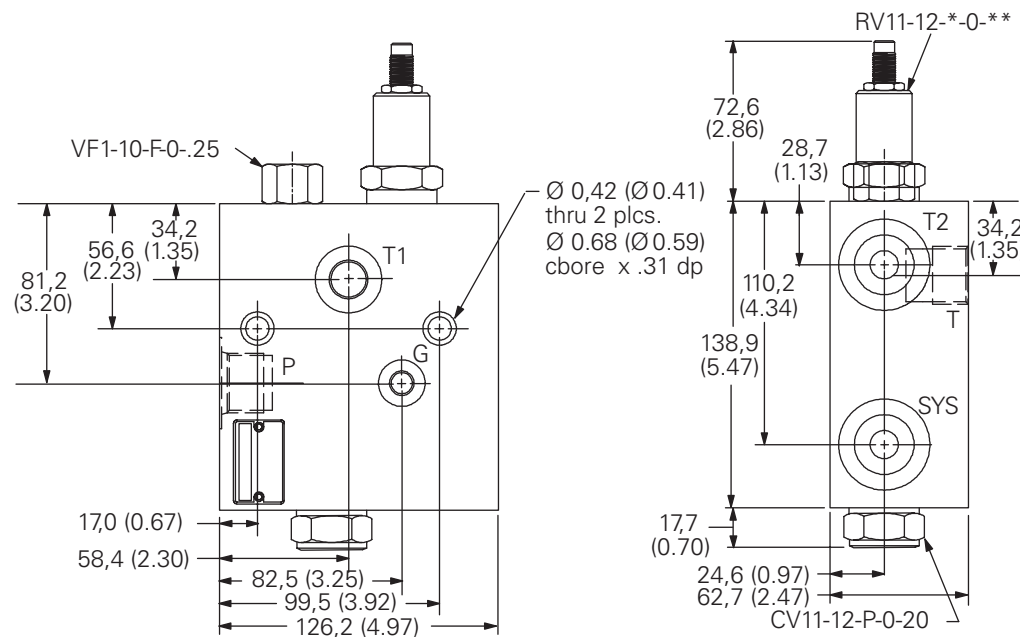

1 Function

PCC2 - Pump control for single pump circuits

2 Size

12 - 12 size

3 Seals

Blank - Buna N
V - Viton®
 Viton is a registered trademark of E.I. DuPont

4 Relief Control

C - Cap
K - Knob
S - Screw

5 Valve Housing Material

A - Aluminum

7 Pressure Range

15 - 5 - 100 bar (75-1500psi)
30 - 10 - 210 bar (150-3000psi)

8 Pressure setting - user requested in 50 PSI steps
 example
10 - 1000psi
10.5 - 1050psi

9 Special Features

00 - None
 (Only required if valve has special features, omitted if "00")

6 Port Size

CODE	P, SYS, T2	T1	GAUGE
6G	3/4" BSPP	1/2" BSPP	1/4" BSPP
12T	SAE 12	SAE 8	SAE 4

COMPOSITION CHART

Cartridge	Description	Maximum Flow	Quantity
VF1-10-F-0-.25	Velocity fuse	23 L/min (6 USgpm)	1
CV11-12-P-0-20	Check valve	113 L/min (30 USgpm)	1
RV11-12-*-0-**/	Relief valve	113 L/min (30 USgpm)	1

Pressure Drop Curve

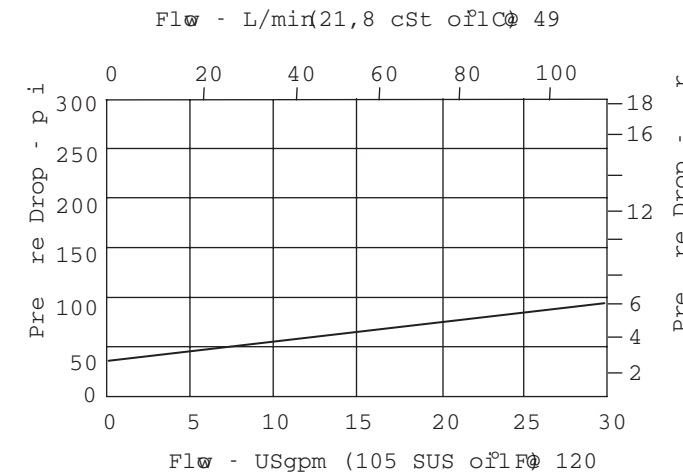

Pressure Override Curves

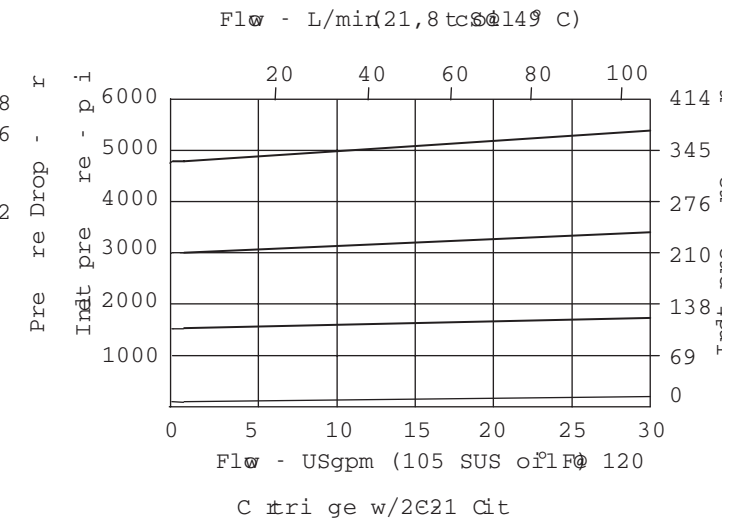

Description

Pump control manifold for multiple pump circuits

Functional Symbol

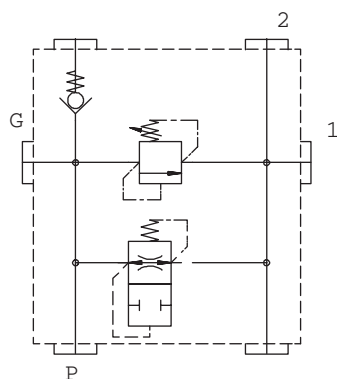

Features

- Individual relief pressure setting for each pump in the system
- Multiple tank ports for mounting convenience
- Direct reservoir mounting capability by using "T" port. Both "T" port and mounting holes have o'ring seals
- Aluminum in-line type housing
- Tamper proof and adjustable relief options
- Gauge port
- All components in the package are true cartridges and can be removed from the housing without disturbing the plumbing.

Application

This standard valve package is used to provide air-bleed, start-up and relief protection for each pump in multiple pump circuits. The check valve position in the circuit isolates the other pumps from the valve assembly.

RATINGS AND SPECIFICATIONS

Typical application pressure range	10 - 210 bar (150 - 3000 psi)
Maximum regulated flow	up to 228 L/min (60 USgpm)
Temperature range	-40° to 120° C (-40° to 248° F)
Reseat pressure	90% of crack pressure
Fluids	All general purpose hydraulic fluids such as: MIL-H-5606, SAE 10, SAE 20, etc.

Dimensions

mm (inch)

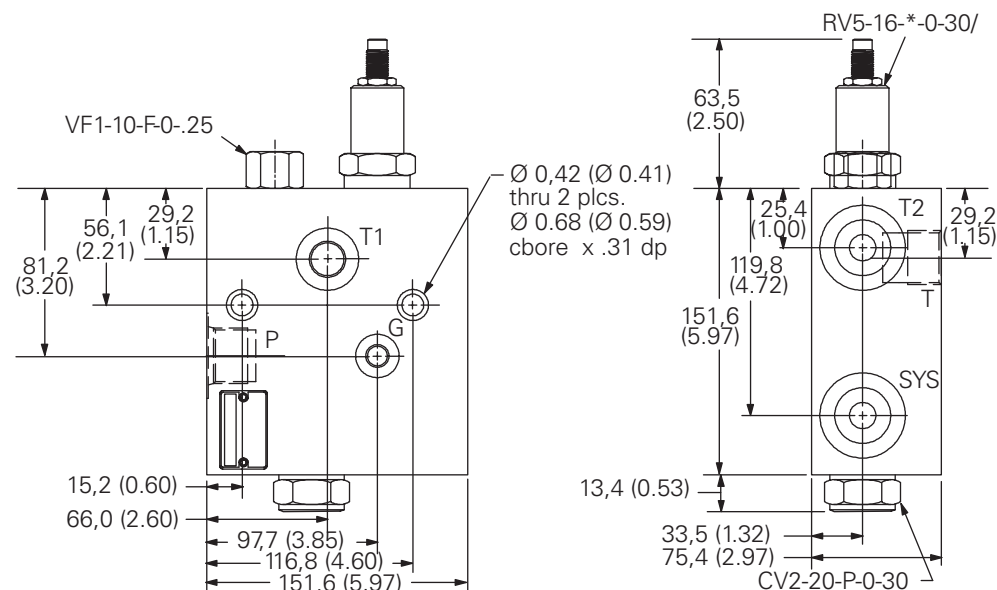

PCC2 - 16 (V) - * - A ** - ** / ** - 00

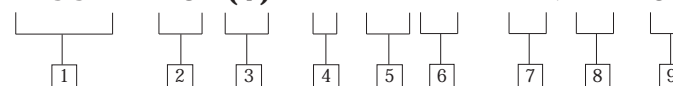

1 Function

PCC2 - Pump control for single pump circuits

2 Size

16 - 16 size

3 Seals

Blank - Buna N
V - Viton®
Viton is a registered trademark of E.I. DuPont

4 Relief Control

C - Cap
K - Knob
S - Screw

5 Valve Housing Material

A - Aluminum

7 Pressure Range

30 - 10 - 210 bar (150-3000 psi)

8 Pressure setting - user requested in 50 PSI steps

example
10 - 1000psi
10.5 - 1050psi

9 Special Features

00 - None
(Only required if valve has special features, omitted if "00")

6 Port Size

CODE	P, SYS, T2	T1	GAUGE
8G	1" BSPP	3/4" BSPP	1/4" BSPP
16T	SAE 16	SAE 12	SAE 4

COMPOSITION CHART

Cartridge	Description	Maximum Flow	Quantity
VF1-10-F-0-.25	Velocity fuse	23 L/min (6 USgpm)	1
CV2-20-P-0-30	Check valve	228 L/min (60 USgpm)	1
RV5-16-* -0-30/	Relief valve	303 L/min (80 USgpm)	1

Pressure Drop Curve

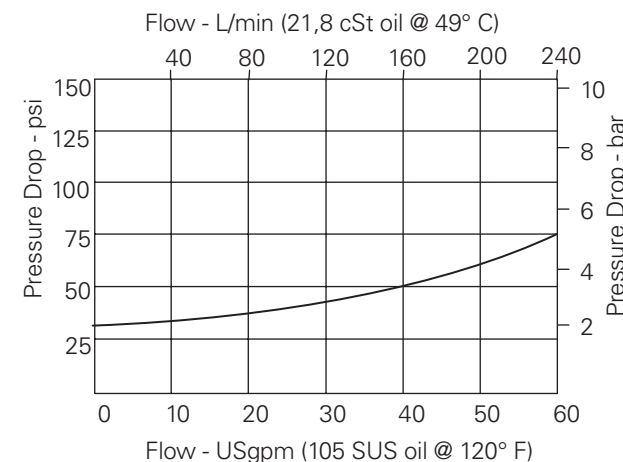

Pressure Override Curves

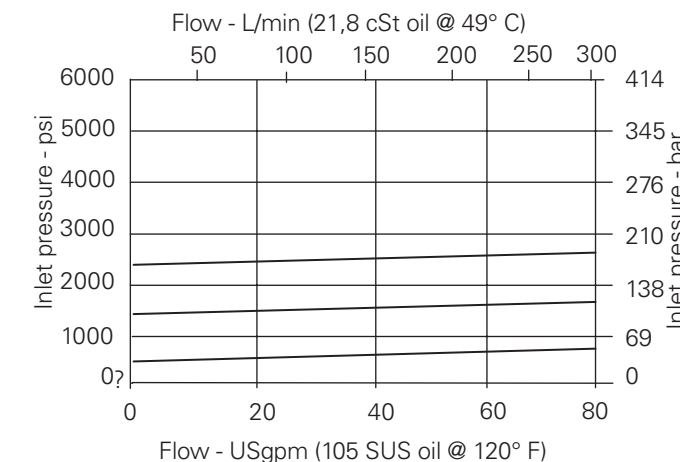

Fixed priority flow control with relief on priority flow port

Description

Fixed priority flow control with relief on priority flow port

Functional Symbol

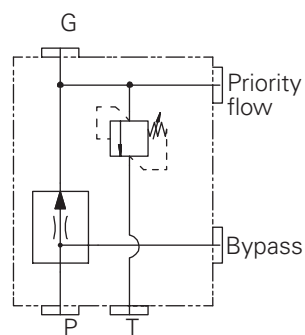

Features

- Priority flow pressure compensation
- All ports except "T" can be pressurized to 210 bar (3000 psi)
- Aluminum in-line type housing
- Tamper proof and adjustable relief options
- Gauge port
- All components in the package are true cartridges and can be removed from the housing without disturbing the plumbing.

Application

This standard valve package is used to maintain constant flow to priority circuits when input flow is greater than required, regardless of changes in upstream or downstream pressure. It will bypass the rest of the flow to an auxiliary circuit or to tank. Relief valve on a priority port limits pressure on a priority port, as well as ensures bypass flow when there is no demand on priority circuit.

RATINGS AND SPECIFICATIONS

Typical application pressure range	7 - 210 bar (100 - 3000 psi)
Maximum inlet flow	15 L/min (4 USgpm)
Regulated flow range	0,4 - 8 L/min (0.1-2.5 USgpm)
Internal leakage	82 cm ³ /min (5 in ³ /min)
Temperature range	-40° to 120° C (-40° to 248° F)
Reseat pressure	90% of crack pressure
Fluids	All general purpose hydraulic fluids such as: MIL-H-5606, SAE 10, SAE 20, etc.

Dimensions

mm (inch)

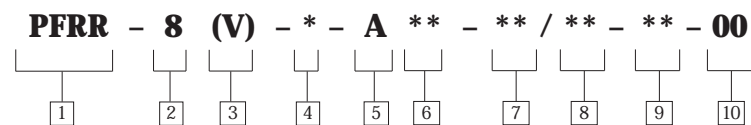
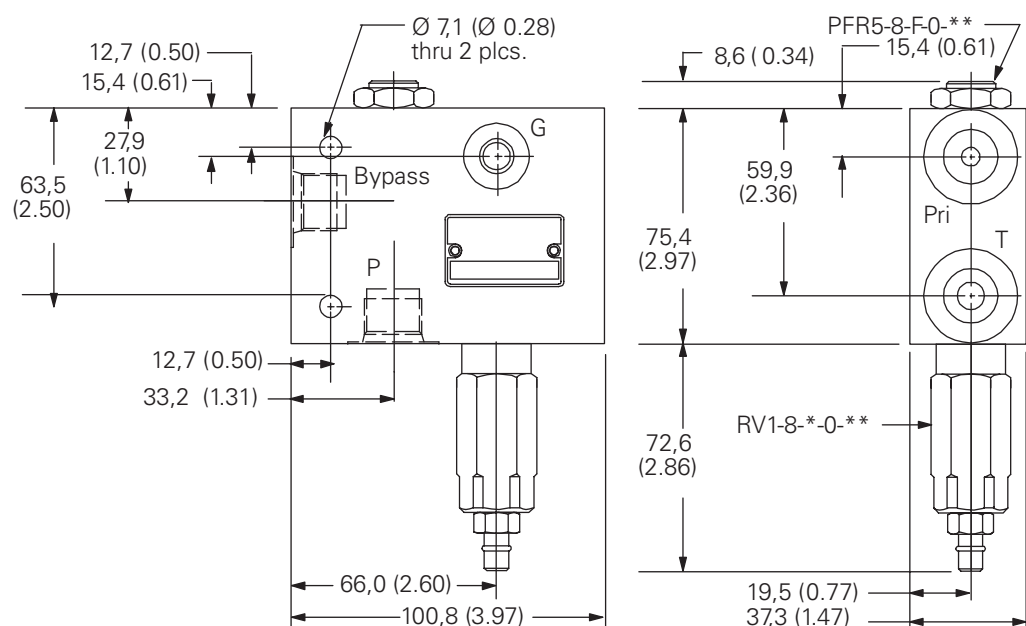

1 Function PFRR - Pressure compensated priority flow control with relief on priority port	4 Relief Control C - Cap K - Knob S - Screw	7 Pressure Range 3 - 3 - 20 bar (50-300psi) 20 - 40 - 140 bar (600-2000psi) 36 - 20 - 250 bar (300-3600psi)	9 Flow Setting Customer must specify flow 0,4 - 8 L/min (0.1 - 2.5 USgpm)															
2 Size 8 - 8 size	5 Valve Housing Material A - Aluminum	8 Pressure setting - user requested in 50 PSI steps example 10 - 1000psi 10.5 - 1050psi	10 Special Features 00 - None (Only required if valve has special features, omitted if "00".)															
3 Seals Blank - Buna N V - Viton® <small>Viton is a registered trademark of E.I. DuPont</small>	6 Port Size	<table border="1"> <thead> <tr> <th>CODE</th> <th>P, BYPASS</th> <th>PRIORITY, T</th> <th>GAUGE</th> <th>HOUSING NUMBER</th> </tr> </thead> <tbody> <tr> <td>3G</td> <td>3/8" BSPP</td> <td>3/8" BSPP</td> <td>1/4" BSPP</td> <td>02-178273</td> </tr> <tr> <td>8T</td> <td>SAE 8</td> <td>SAE 8</td> <td>SAE 4</td> <td>02-178274</td> </tr> </tbody> </table>		CODE	P, BYPASS	PRIORITY, T	GAUGE	HOUSING NUMBER	3G	3/8" BSPP	3/8" BSPP	1/4" BSPP	02-178273	8T	SAE 8	SAE 8	SAE 4	02-178274
CODE	P, BYPASS	PRIORITY, T	GAUGE	HOUSING NUMBER														
3G	3/8" BSPP	3/8" BSPP	1/4" BSPP	02-178273														
8T	SAE 8	SAE 8	SAE 4	02-178274														

COMPOSITION CHART

Cartridge	Description	Quantity
PFR5-8-F-0-**-**	Priority flow regulator	1
RV1-8-* -0-**-**	Relief valve	1

Typical Flow Regulation

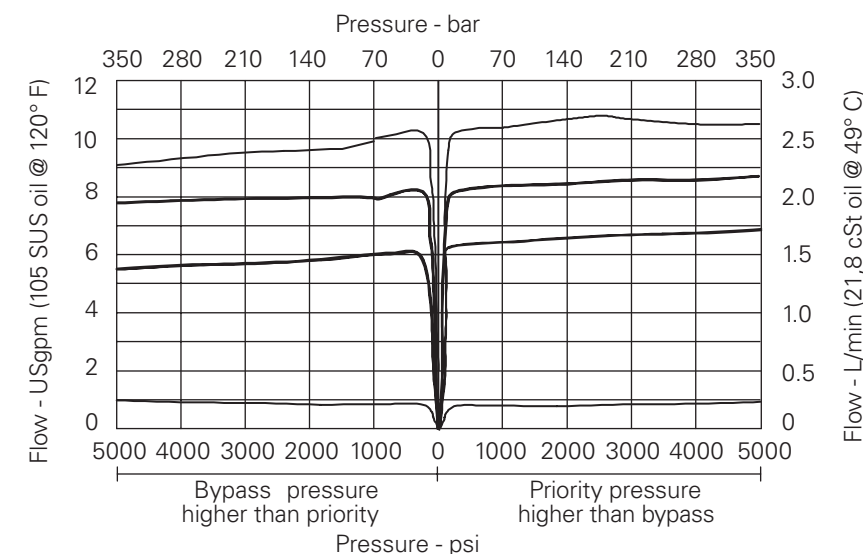

Fixed priority flow control with relief on priority flow port

Description

Fixed priority flow control with relief on priority flow port

Functional Symbol

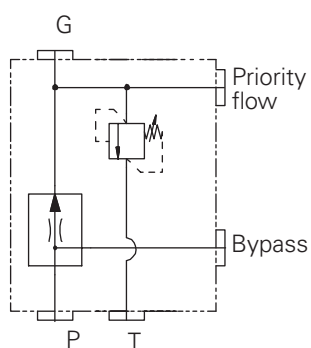

Features

- Priority flow pressure compensation
- All ports except "T" can be pressurized to 210 bar (3000 psi)
- Aluminum in-line type housing
- Tamper proof and adjustable relief options
- Gauge port
- All components in the package are true cartridges and can be removed from the housing without disturbing the plumbing.

Application

This standard valve package is used to maintain constant flow to priority circuits when input flow is greater than required, regardless of changes in upstream or downstream pressure. It will bypass the rest of the flow to an auxiliary circuit or to tank. Relief valve on a priority port limits pressure on a priority port, as well as ensures bypass flow when there is no demand on priority circuit.

RATINGS AND SPECIFICATIONS

Typical application pressure range	7 - 210 bar (100 - 3000 psi)
Maximum inlet flow	57 L/min (15 USgpm)
Regulated flow range	0,38 - 22,7 L/min (0.1-6 USgpm)
Internal leakage	82 cm ³ /min (5 in ³ /min)
Temperature range	-40° to 120° C (-40° to 248° F)
Reset pressure	90% of crack pressure
Fluids	All general purpose hydraulic fluids such as: MIL-H-5606, SAE 10, SAE 20, etc.

Dimensions

mm (inch)

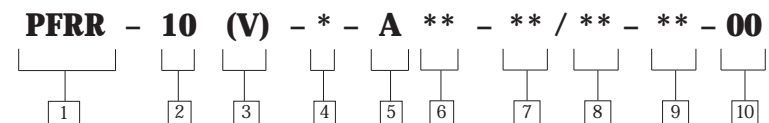
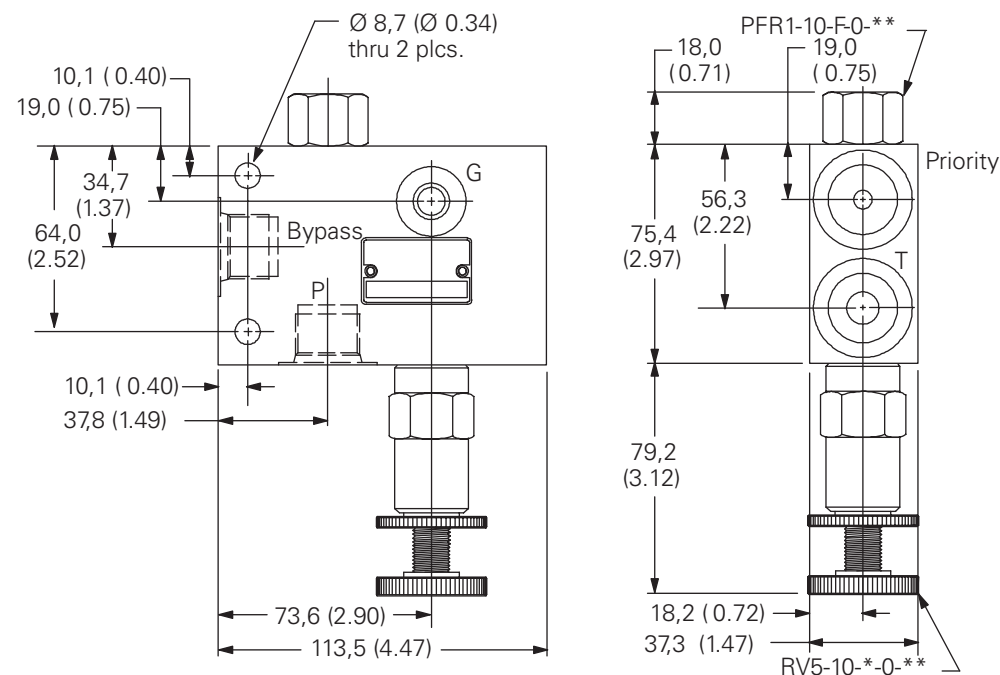

1 Function PFRR - Pressure compensated priority flow control with relief on priority port	4 Relief Control C - Cap K - Knob S - Screw	7 Pressure Range 3 - 3 - 20 bar (50-300psi) 20 - 7 - 140 bar (100-2000psi) 35 - 17 - 240 bar (250-3500psi)	9 Flow Setting Customer must specify flow 0,38-22,7 L/min (0.1 - 6 USgpm)															
2 Size 10 - 10 size	5 Valve Housing Material A - Aluminum	8 Pressure setting - user requested in 50 PSI steps example 10 - 1000psi 10.5 - 1050psi	10 Special Features 00 - None (Only required if valve has special features, omitted if "00")															
3 Seals Blank - Buna N V - Viton® <small>Viton is a registered trademark of E.I. DuPont</small>	6 Port Size	<table border="1"> <thead> <tr> <th>CODE</th> <th>P, BYPASS</th> <th>PRIORITY, T</th> <th>GAUGE</th> <th>HOUSING NUMBER</th> </tr> </thead> <tbody> <tr> <td>4G</td> <td>3/8" BSPP</td> <td>1/2" BSPP</td> <td>1/4" BSPP</td> <td>02-178275</td> </tr> <tr> <td>10T</td> <td>SAE 8</td> <td>SAE 8</td> <td>SAE 4</td> <td>02-178276</td> </tr> </tbody> </table>		CODE	P, BYPASS	PRIORITY, T	GAUGE	HOUSING NUMBER	4G	3/8" BSPP	1/2" BSPP	1/4" BSPP	02-178275	10T	SAE 8	SAE 8	SAE 4	02-178276
CODE	P, BYPASS	PRIORITY, T	GAUGE	HOUSING NUMBER														
4G	3/8" BSPP	1/2" BSPP	1/4" BSPP	02-178275														
10T	SAE 8	SAE 8	SAE 4	02-178276														

COMPOSITION CHART

Cartridge	Description	Quantity
PFR1-10-F-0-**-**	Priority flow regulator	1
RV5-10-**-0-35/	Relief valve	1

Typical Flow Regulation

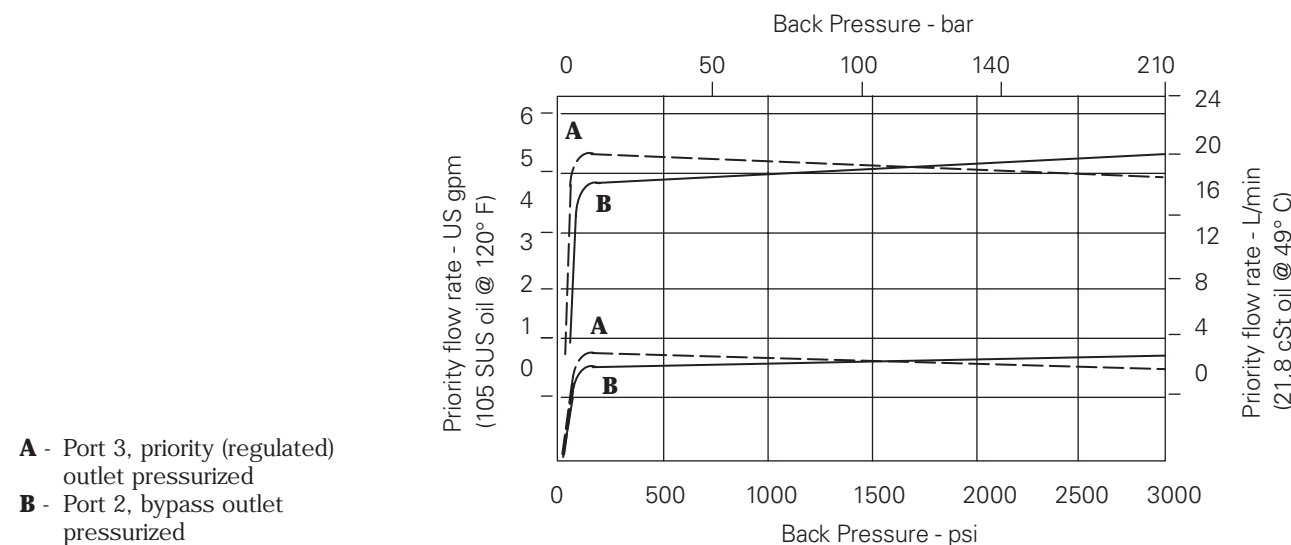

Fixed priority flow control with relief on priority flow port

Description

Fixed priority flow control with relief on priority flow port

Functional Symbol

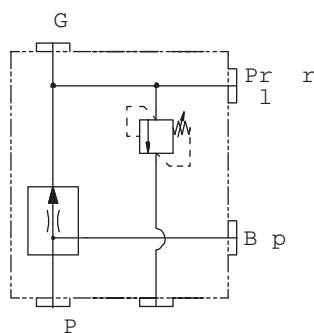

Features

- Priority flow pressure compensation
- All ports except "T" can be pressurized to 210 bar (3000 psi)
- Aluminum in-line type housing
- Tamper proof and adjustable relief options
- Gauge port
- All components in the package are true cartridges and can be removed from the housing without disturbing the plumbing.

Application

This standard valve package is used to maintain constant flow to priority circuits when input flow is greater than required, regardless of changes in upstream or downstream pressure. It will bypass the rest of the flow to an auxiliary circuit or to tank. Relief valve on a priority port limits pressure on a priority port, as well as ensures bypass flow when there is no demand on priority circuit.

RATINGS AND SPECIFICATIONS

Typical application pressure range	7 - 210 bar (100 - 3000 psi)
Maximum inlet flow	152 L/min (40 USgpm)
Regulated flow range	1,9 - 113 L/min (0.5-30 USgpm)
Internal leakage	82 cm ³ /min (5 in ³ /min)
Temperature range	-40° to 120° C (-40° to 248° F)
Reseat pressure	90% of crack pressure
Fluids	All general purpose hydraulic fluids such as: MIL-H-5606, SAE 10, SAE 20, etc.

Dimensions

mm (inch)

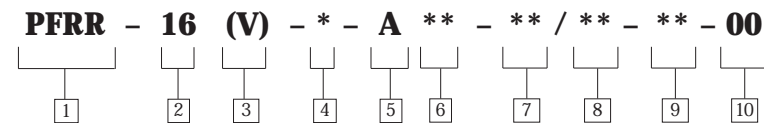
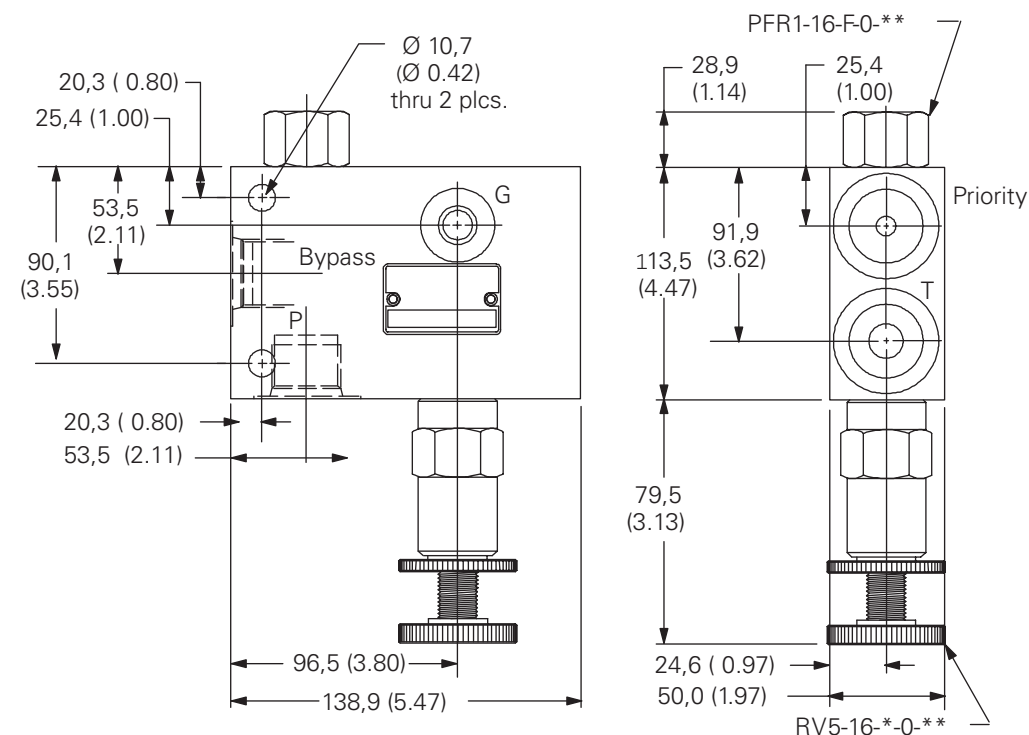

1 Function PFRR - Pressure compensated priority flow control with relief on priority port	4 Relief Control C - Cap K - Knob S - Screw	7 Pressure Range 3 - 3 - 20 bar (50-300psi) 20 - 7 - 140 bar (100-2000psi) 35 - 17 - 240 bar (250-3500psi)	9 Flow Setting Customer must specify flow 0,38-22,7 L/min (0.1 - 6 USgpm)															
2 Size 16 - 16 size	5 Valve Housing Material A - Aluminum	8 Pressure setting - user requested in 50 PSI steps example 10 - 1000psi 10.5 - 1050psi	10 Special Features 00 - None (Only required if valve has special features, omitted if "00")															
3 Seals Blank - Buna N V - Viton® <small>Viton is a registered trademark of E.I. DuPont</small>	6 Port Size	<table border="1"> <thead> <tr> <th>CODE</th> <th>P, BYPASS</th> <th>PRIORITY, T</th> <th>GAUGE</th> <th>HOUSING NUMBER</th> </tr> </thead> <tbody> <tr> <td>8G</td> <td>1" BSPP</td> <td>3/4" BSPP</td> <td>1/4" BSPP</td> <td>02-178277</td> </tr> <tr> <td>16T</td> <td>SAE 16</td> <td>SAE 12</td> <td>SAE 4</td> <td>02-178278</td> </tr> </tbody> </table>		CODE	P, BYPASS	PRIORITY, T	GAUGE	HOUSING NUMBER	8G	1" BSPP	3/4" BSPP	1/4" BSPP	02-178277	16T	SAE 16	SAE 12	SAE 4	02-178278
CODE	P, BYPASS	PRIORITY, T	GAUGE	HOUSING NUMBER														
8G	1" BSPP	3/4" BSPP	1/4" BSPP	02-178277														
16T	SAE 16	SAE 12	SAE 4	02-178278														

COMPOSITION CHART

Cartridge	Description	Quantity
PFR1-16-F-0-**-**	Priority flow regulator	1
RV5-10-**-0-**-**	Relief valve	1

Typical Flow Regulation

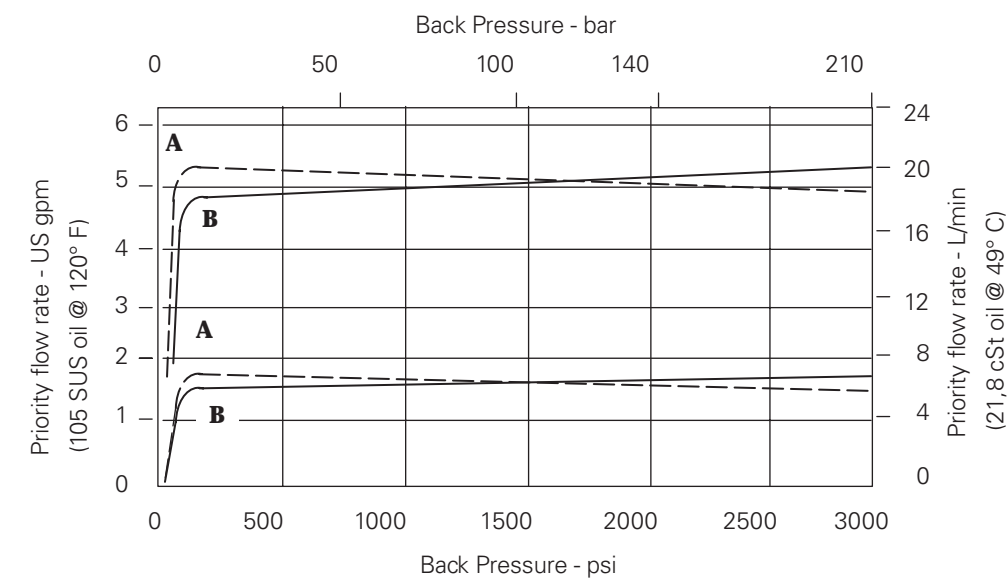

- A - Port 3, priority (regulated) outlet pressurized
- B - Port 2, bypass outlet pressurized

Description

Solenoid actuated relief valve

Functional Symbols

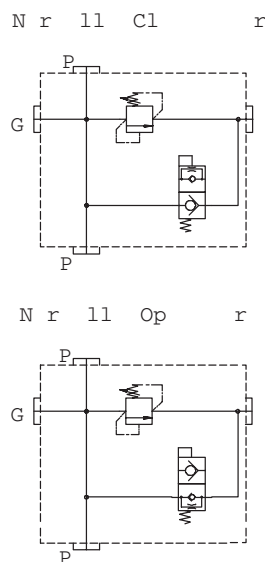

Dimensions

mm (inch)

Features

- Normally closed and normally open options
- Tamper proof or adjustable relief options
- Low power requirements
- Gauge port
- Aluminum in-line type housing
- Number of voltage and connector options
- All components in the package are true cartridges and can be removed from the housing without disturbing the plumbing

Application

This standard valve package is designed for pump unloading via solenoid valve activation and pump relief, when the solenoid valve is not activated and system pressure reaches relief valve setting.

RATINGS AND SPECIFICATIONS

Typical application pressure	210 bar (3000 psi)
Flow rating	23 L/min (6 USgpm)
Internal leakage	5 drops/min. @ 80% of crack pressure
Reseat pressure	80% of crack pressure
Typical vented ΔP	4 bar (60 psi) at rated flow
Coil specifications	
Power requirements	16 watts
Coil duty	continuous from 85% to 110% of nominal voltage (AC coils are internally rectified)
Temperature range	-40° to 120° C (-40° to 248° F)
Fluids	All general purpose hydraulic fluids such as: MIL-H-5606, SAE 10, SAE 20, etc.

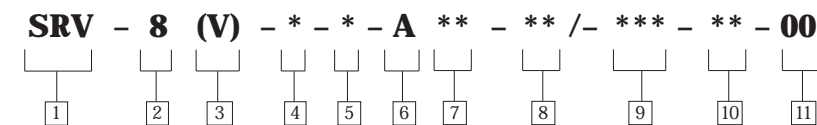
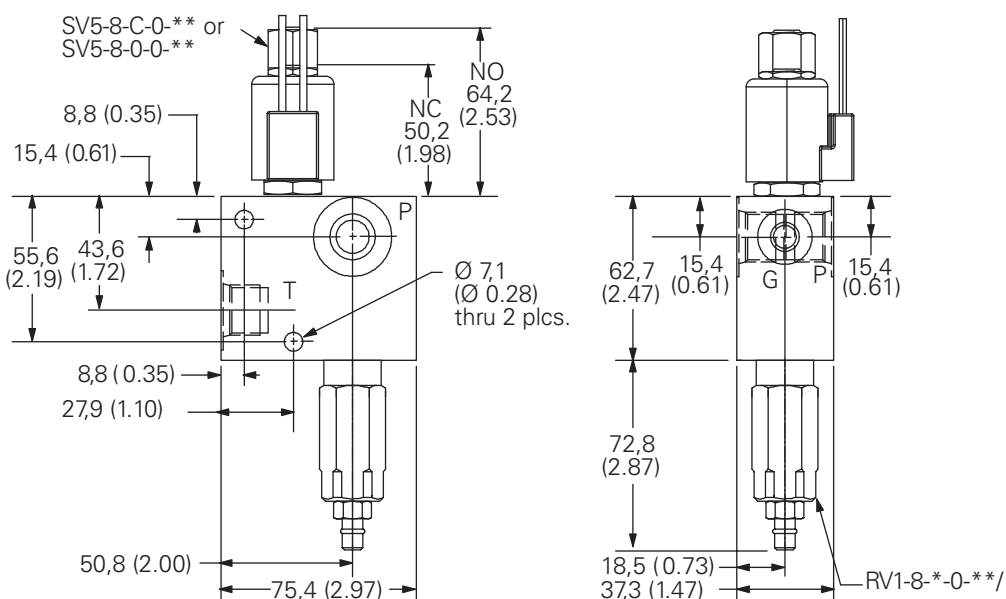

- | <p>1 Function
SRV - Solenoid actuated relief valve</p> <p>2 Size
8 - 8 size</p> <p>3 Seals
Blank - Buna N
V - Viton®
<small>Viton is a registered trademark of E.I. DuPont</small></p> <p>4 Type
C - Normally closed
O - Normally open</p> | <p>5 Relief Control
C - Cap
K - Knob
S - Screw</p> <p>6 Valve Housing Material
A - Aluminum</p> <p>7 Port Size</p> <table border="1"> <thead> <tr> <th>CODE</th> <th>P.T</th> <th>GAUGE</th> <th>HOUSING</th> </tr> </thead> <tbody> <tr> <td>3G</td> <td>3/8" BSPP</td> <td>1/4 BSPP</td> <td>02-178306</td> </tr> <tr> <td>8T</td> <td>SAE 8</td> <td>SAE 4</td> <td>02-178307</td> </tr> </tbody> </table> | CODE | P.T | GAUGE | HOUSING | 3G | 3/8" BSPP | 1/4 BSPP | 02-178306 | 8T | SAE 8 | SAE 4 | 02-178307 | <p>8 Relief Pressure Range
3 - 3 - 20 bar (50-300psi)
36 -20 - 240 bar (300-3600psi)</p> <p>9 Voltage Rating
12D - 12VDC
24D - 24VDC
120A - 120VAC
240A - 240VAC</p> | <p>10 Connector types
GS - ISO 4400 DIN 43650 connector
PS - 1/2" NPT conduit
WS - Leadwire</p> <p>11 Special Features
00 - None
(Only required if valve has special features, omitted if "00")</p> |
|--|--|----------|-----------|-------|---------|----|-----------|----------|-----------|----|-------|-------|-----------|--|---|
| CODE | P.T | GAUGE | HOUSING | | | | | | | | | | | | |
| 3G | 3/8" BSPP | 1/4 BSPP | 02-178306 | | | | | | | | | | | | |
| 8T | SAE 8 | SAE 4 | 02-178307 | | | | | | | | | | | | |

COMPOSITION CHART

Cartridge	Description	Quantity
SV5-8-0-0-**-**	2 way/2 position N.O. poppet solenoid valve	1
SV5-8-C-0-**-**	2 way/2 position N.C. poppet solenoid valve	1
RV1-8-*-0-**-**	Relief valve, direct acting	1

Pressure Drop Curve (unloading)

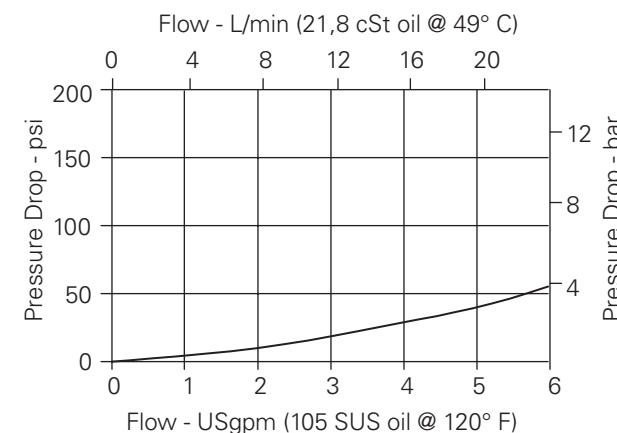

Pressure Override Curves

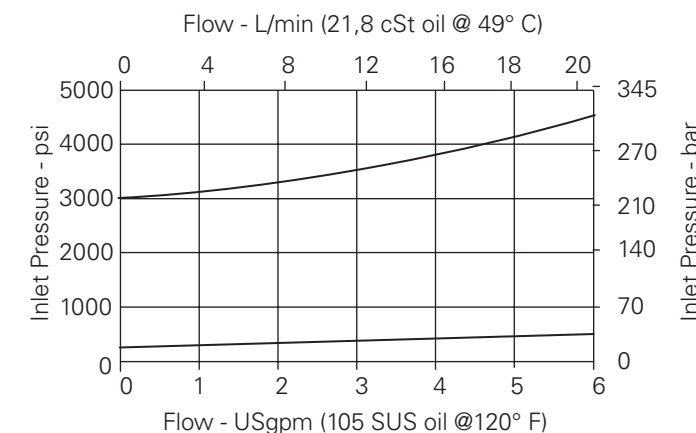

Description

Solenoid actuated relief valve

Functional Symbol

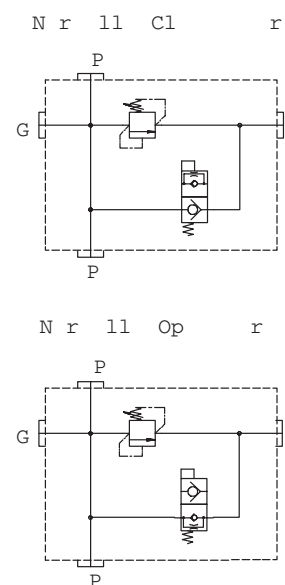

Dimensions

mm (inch)

Features

- Normally closed and normally open options
- Tamper proof or adjustable relief options
- Low power requirements
- Gauge port
- Aluminum in-line type housing
- Number of voltage and connector options
- All components in the package are true cartridges and can be removed from the housing without disturbing the plumbing

Application

This standard valve package is designed for pump unloading via solenoid valve activation and pump relief, when the solenoid valve is not activated and system pressure reaches relief valve setting.

RATINGS AND SPECIFICATIONS

Typical application pressure	210 bar (3000 psi)
Flow rating	57 L/min (15 USgpm)
Internal leakage	80 cm ³ /min (5 in ³ /min) @ 210 bar (3000 psi)
Reseat pressure	80% of crack pressure
Typical vented ΔP	7 bar (100 psi) at rated flow
Coil specifications	
Power requirements	18 watts
Coil duty	continuous from 85% to 110% of nominal voltage (AC coils are internally rectified)
Temperature range	-40° to 120° C (-40° to 248° F)
Fluids	All general purpose hydraulic fluids such as: MIL-H-5606, SAE 10, SAE 20, etc.

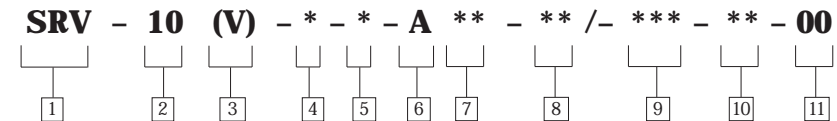
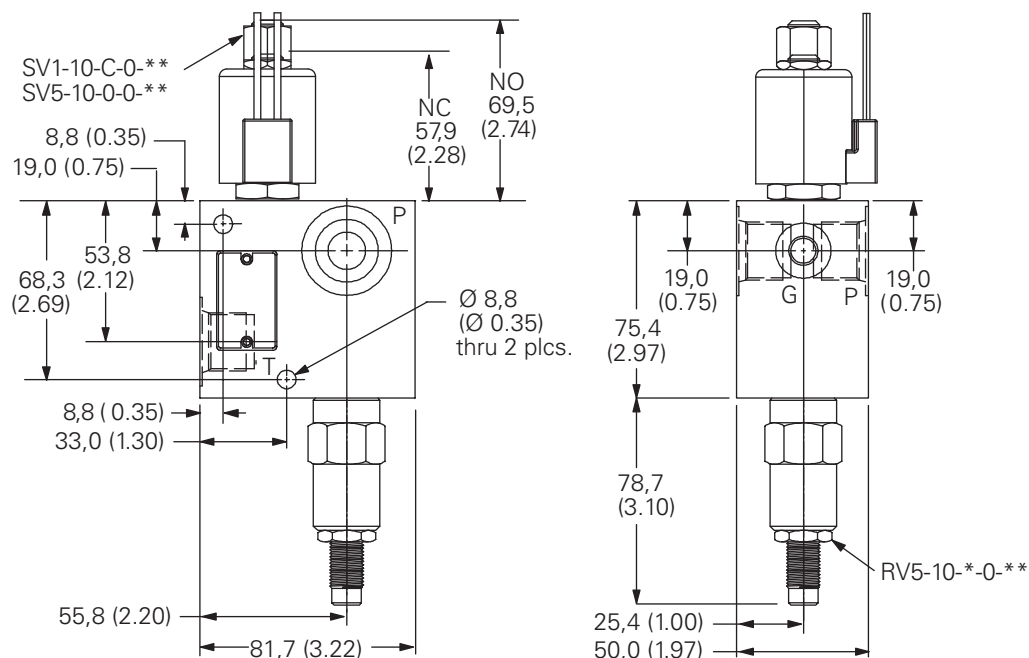

- | 1 Function
SRV - Solenoid actuated relief valve | 5 Relief Control
C - Cap
K - Knob
S - Screw | 8 Relief Pressure Range
3 - 3 - 20 bar (50-300psi)
35 -17 - 240 bar (250-3500psi) | 10 Connector types
G - ISO 4400 DIN 43650 connector
P - 1/2" NPT conduit
W - Leadwire | | | | | | | | | | | | |
|---|---|---|---|------|----|-------|---------|----|-----------|----------|-----------|-----|--------|-------|-----------|
| 2 Size
10 - 10 size | 6 Valve Housing Material
A - Aluminum | 9 Voltage Rating
12D - 12VDC
24D - 24VDC
115A - 115VAC
230A - 230VAC | 11 Special Features
00 - None
(Only required if valve has special features, omitted if "00") | | | | | | | | | | | | |
| 3 Seals
Blank - Buna N
V - Viton®
<small>Viton is a registered trademark of E.I. DuPont</small> | 7 Port Size | <table border="1"> <thead> <tr> <th>CODE</th> <th>PT</th> <th>GAUGE</th> <th>HOUSING</th> </tr> </thead> <tbody> <tr> <td>4G</td> <td>1/2" BSPP</td> <td>1/4 BSPP</td> <td>02-178308</td> </tr> <tr> <td>10T</td> <td>SAE 10</td> <td>SAE 4</td> <td>02-178309</td> </tr> </tbody> </table> | | CODE | PT | GAUGE | HOUSING | 4G | 1/2" BSPP | 1/4 BSPP | 02-178308 | 10T | SAE 10 | SAE 4 | 02-178309 |
| CODE | PT | GAUGE | HOUSING | | | | | | | | | | | | |
| 4G | 1/2" BSPP | 1/4 BSPP | 02-178308 | | | | | | | | | | | | |
| 10T | SAE 10 | SAE 4 | 02-178309 | | | | | | | | | | | | |
| 4 Type
C - Normally closed
O - Normally open | | | | | | | | | | | | | | | |

COMPOSITION CHART

Cartridge	Description	Quantity
SV5-10-0-0-**-**	2 way/2 position N.O. poppet solenoid valve	1
SV1-10-C-0-**-**	2 way/2 position N.C. poppet solenoid valve	1
RV5-10-*0-**-**	Relief valve, pilot operated	1

Pressure Drop Curve (unloading)

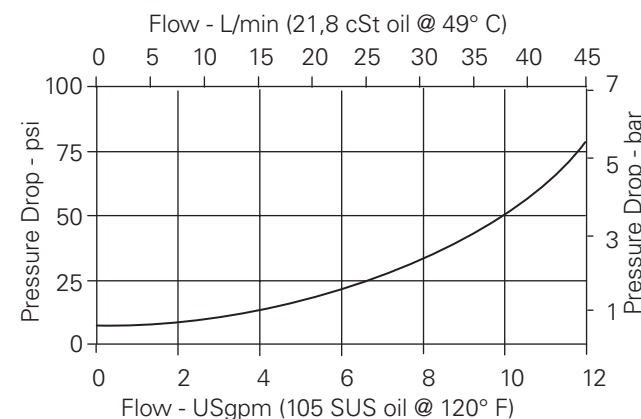

Pressure Override Curves

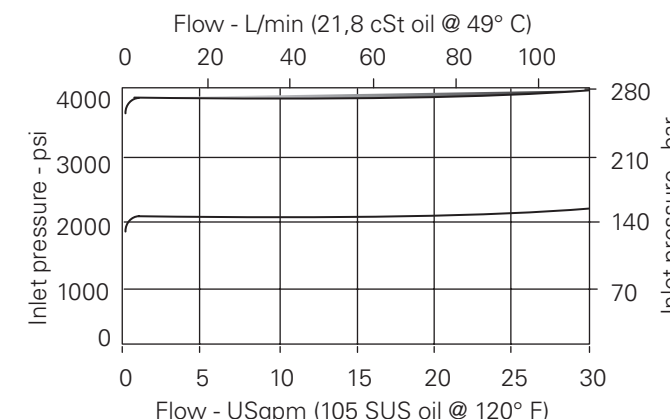

Description

Solenoid actuated vented relief valve

Functional Symbol

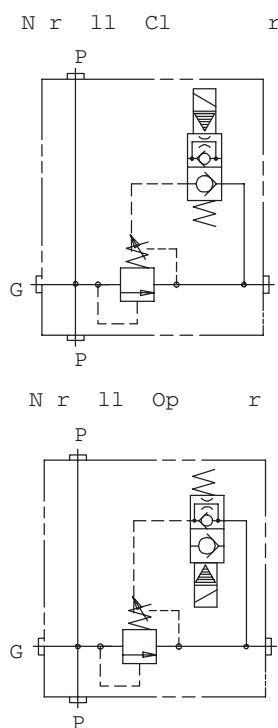

Dimensions

mm (inch)

Features

- Normally closed and normally open options
- Tamper proof or adjustable relief options
- Low power requirements
- Gauge port
- Aluminum in-line type housing
- Number of voltage and connector options
- All components in the package are true cartridges and can be removed from the housing without disturbing the plumbing

Application

This standard valve package is designed for pump unloading via solenoid valve activation to control remotely ventable relief valve and system relief, when the solenoid valve is not activated.

RATINGS AND SPECIFICATIONS

Typical application pressure	210 bar (3000 psi)
Flow rating	114 L/min (30 USgpm)
Internal leakage	82 cm ³ /min (5 in ³ /min) maximum
Reseat pressure	90% of crack pressure
Typical vented ΔP	10 bar (150 psi) at rated flow
Coil specifications	
Power requirements	16 watts
Coil duty	continuous from 85% to 110% of nominal voltage (AC coils are internally rectified)
Temperature range	-40° to 120° C (-40° to 248° F).
Fluids	All general purpose hydraulic fluids such as: MIL-H-5606, SAE 10, SAE 20, etc.

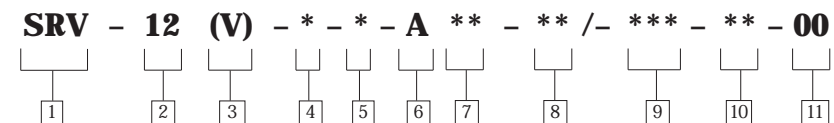
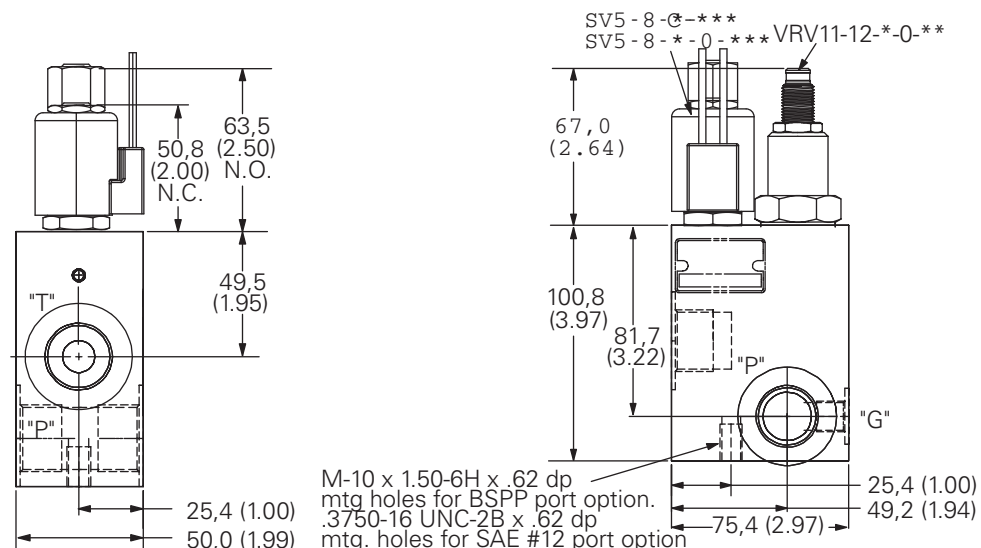

1 Function SRV - Solenoid operated ventable relief valve	5 Relief Control C - Cap K - Knob S - Screw	8 Relief Pressure Range 15 - 5 - 103 bar (75-1500psi) 30 - 10 - 207 bar (50-3000psi)	10 Connector types GS - ISO 4400 DIN 43650 connector PS - 1/2" NPT conduit WS - Leadwire												
2 Size 12 - 12 size	6 Valve Housing Material A - Aluminum	9 Voltage Rating 12D - 12VDC 24D - 24VDC 120A - 120VAC 240A - 240VAC	11 Special Features 00 - None (Only required if valve has special features, omitted if "00")												
3 Seals Blank - Buna N V - Viton® <small>Viton is a registered trademark of E.I. DuPont</small>	7 Port Size	<table border="1"> <thead> <tr> <th>CODE</th> <th>P.T</th> <th>GAUGE</th> <th>HOUSING</th> </tr> </thead> <tbody> <tr> <td>6G</td> <td>3/4" BSPP</td> <td>1/4 BSPP</td> <td>02-184898</td> </tr> <tr> <td>12T</td> <td>SAE 12</td> <td>SAE #4</td> <td>02-184899</td> </tr> </tbody> </table>		CODE	P.T	GAUGE	HOUSING	6G	3/4" BSPP	1/4 BSPP	02-184898	12T	SAE 12	SAE #4	02-184899
CODE	P.T	GAUGE	HOUSING												
6G	3/4" BSPP	1/4 BSPP	02-184898												
12T	SAE 12	SAE #4	02-184899												
4 Type C - Normally closed O - Normally open															

COMPOSITION CHART

Cartridge	Description	Quantity
SV5-8-0-0-**-**	2 way/2 position N.O poppet solenoid valve	1
SV5-8-C-0-**-**	2 way/2 position N.C poppet solenoid valve	1
VRV11-12-* -0-**-**	Vented relief valve	1

Pressure Drop Curves (pressure override)

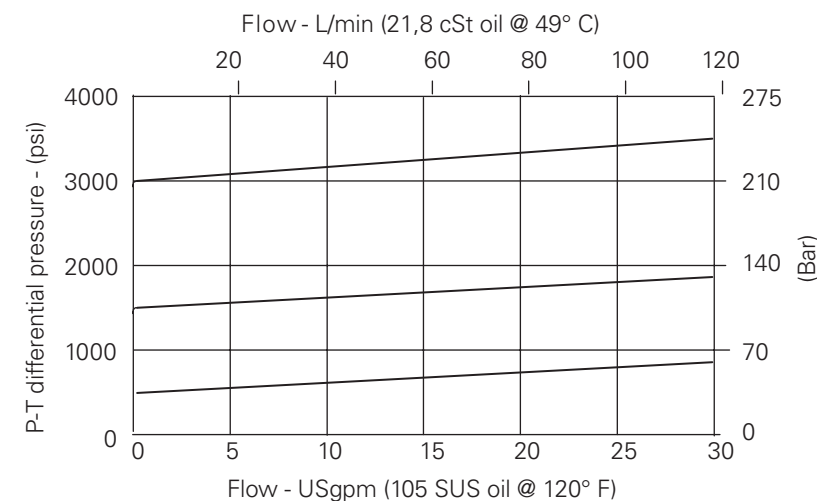

Description

Solenoid actuated relief valve

Functional Symbol

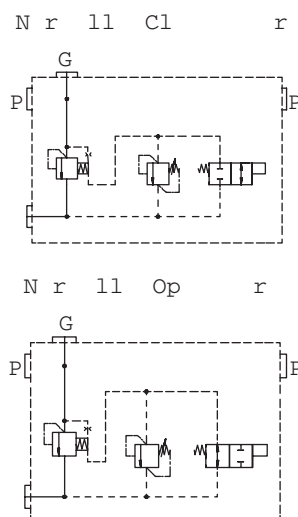

Dimensions

mm (inch)

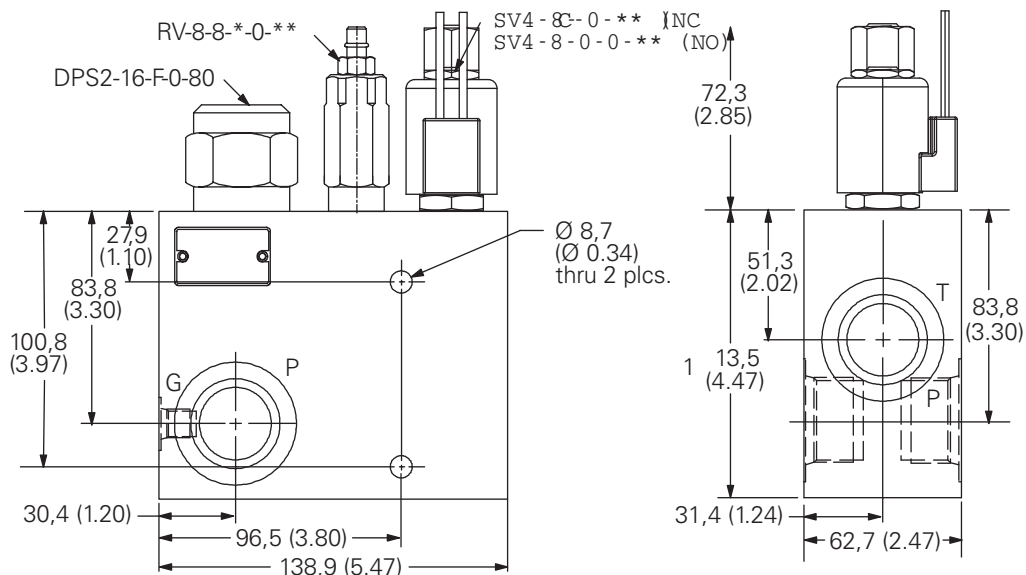

Features

- Normally closed and normally open options
- Tamper proof or adjustable relief options
- Low power requirements
- Gauge port
- Aluminum in-line type housing
- Number of voltage and connector options
- All components in the package are true cartridges and can be removed from the housing without disturbing the plumbing

Application

This standard valve package is designed for pump unloading via solenoid valve activation and pump relief, when the solenoid valve is not activated and system pressure reaches relief valve setting.

RATINGS AND SPECIFICATIONS

Typical application pressure	210 bar (3000 psi)
Flow rating	225 L/min (60 USgpm)
Internal leakage	160 L/min (10 in ³ /min) @ 210 bar (3000 psi)
Reseat pressure	80% of crack pressure
Typical vented ΔP	8 bar (120 psi) at rated flow
Coil specifications	
Power requirements	16 watts
Coil duty	continuous from 85% to 110% of nominal voltage (AC coils are internally rectified)
Temperature range	-40° to 120° C (-40° to 248° F)
Fluids	All general purpose hydraulic fluids such as: MIL-H-5606, SAE 10, SAE 20, etc.

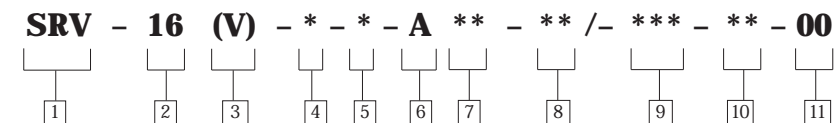

1 Function SRV - Solenoid actuated relief valve	5 Relief Control C - Cap K - Knob S - Screw	8 Relief Pressure Range 15 - 3 - 100 bar (50-1500psi) 30 - 70-210 bar (1000-3000psi)	240A - 240VAC											
2 Size 16 - 16 size	6 Valve Housing Material A - Aluminum	9 Voltage Rating 12D - 12VDC 24D - 24VDC 120A - 120VAC	11 Special Features 00 - None (Only required if valve has special features, omitted if "00")											
3 Seals Blank - Buna N V - Viton® <small>Viton is a registered trademark of E.I. DuPont</small>	7 Port Size													
4 Type C - Normally closed O - Normally open	<table border="1"> <thead> <tr> <th>CODE</th> <th>P/T</th> <th>GAUGE</th> </tr> </thead> <tbody> <tr> <td>8G</td> <td>1" BSPP</td> <td>1/4 BSPP</td> </tr> <tr> <td>16T</td> <td>SAE 16</td> <td>SAE #4</td> </tr> <tr> <td>12T</td> <td>SAE 12</td> <td>SAE #4</td> </tr> </tbody> </table>	CODE	P/T	GAUGE	8G	1" BSPP	1/4 BSPP	16T	SAE 16	SAE #4	12T	SAE 12	SAE #4	
CODE	P/T	GAUGE												
8G	1" BSPP	1/4 BSPP												
16T	SAE 16	SAE #4												
12T	SAE 12	SAE #4												

COMPOSITION CHART

Cartridge	Description	Quantity
SV4-18-0-0-**-**	2 way/2 position N.O. poppet solenoid valve	1
SV4-8-C-0-0-**-**	2 way/2 position N.C. poppet solenoid valve	1
RV8-8-**-0-**-**	Relief valve	1
DPS2-16-V-F-0-80	Differential pressure sensing valve	1

Pressure Drop Curve (unload)

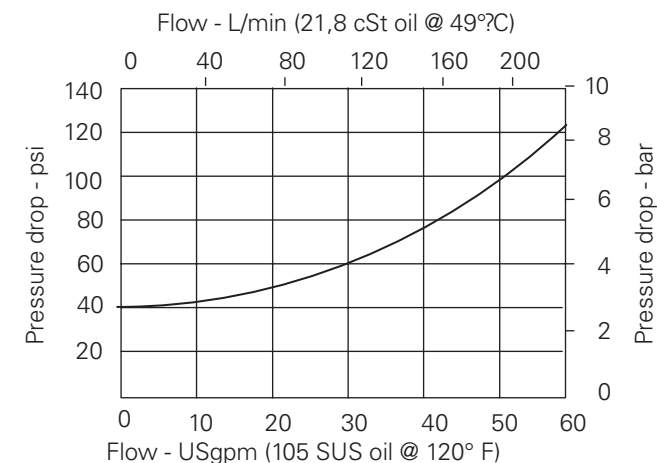

Pressure Override Curves

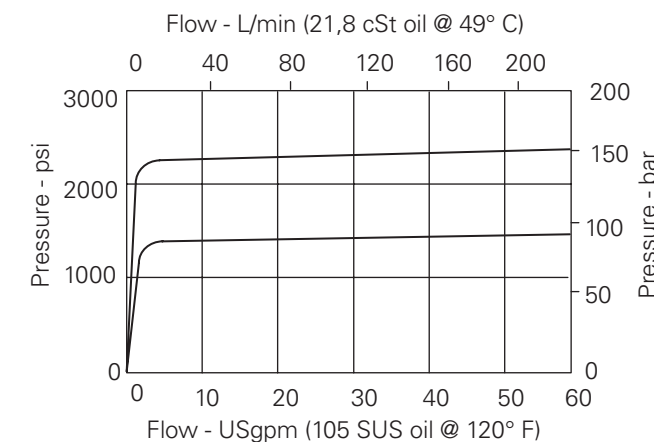

Description

Solenoid actuated relief valve

Functional Symbol

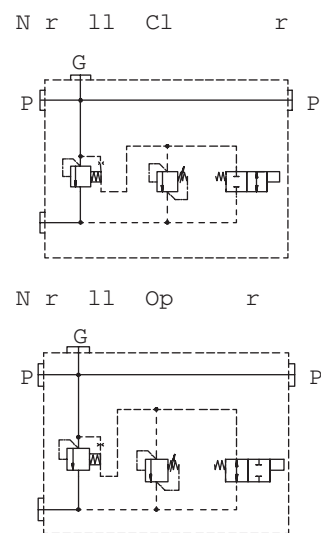

Dimensions

mm (inch)

Features

- Normally closed and normally open options
- Tamper proof or adjustable relief options
- Low power requirements
- Gauge port
- Aluminum in-line type housing
- Number of voltage and connector options
- All components in the package are true cartridges and can be removed from the housing without disturbing the plumbing

Application

This standard valve package is designed for pump unloading via solenoid valve activation and pump relief when the solenoid valve is not activated and system pressure reaches relief valve setting.

RATINGS AND SPECIFICATIONS

Typical application pressure	210 bar (3000 psi)
Flow rating	300 L/min (80 USgpm)
Internal leakage	160 cm ³ /min (10 in ³ /min) @ 210 bar (3000 psi)
Reseat pressure	80% of crack pressure
Typical vented ΔP	9 bar (135 psi) at rated flow
Coil specifications	
Power requirements	16 watts
Coil duty	continuous from 85% to 110% of nominal voltage (AC coils are internally rectified)
Temperature range	-40° to 120° C (-40° to 248° F).
Fluids	All general purpose hydraulic fluids such as: MIL-H-5606, SAE 10, SAE 20, etc.

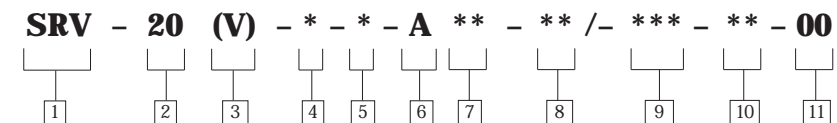
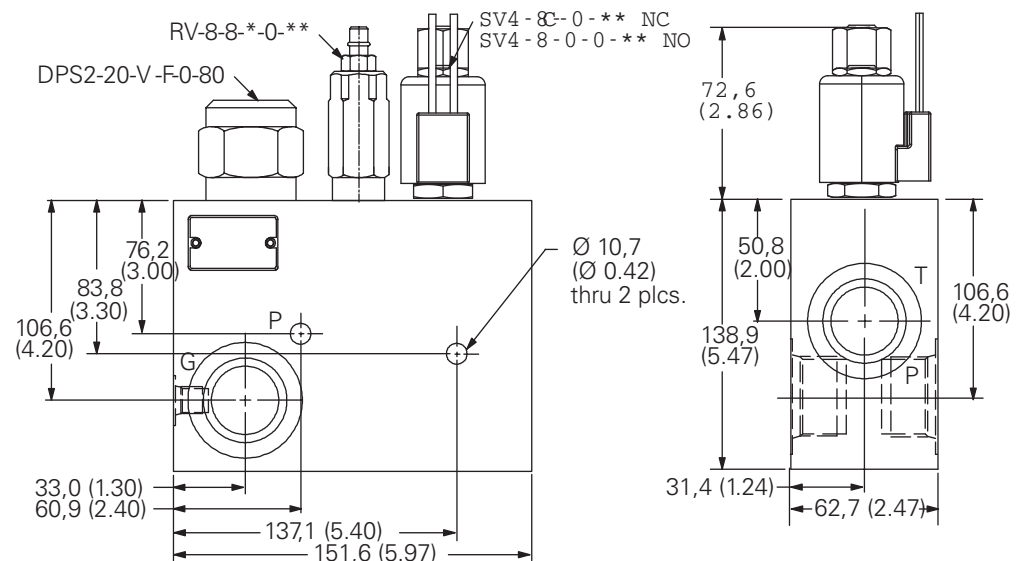

1 Function SRV - Solenoid actuated relief valve	5 Relief Control C - Cap K - Knob S - Screw	8 Relief Pressure Range 15 - 3 - 100 bar (50-1500 psi) 30 - 70-210 bar (1000-3000 psi)	10 Connector types GS - ISO 4400 DIN 43650 connector PS - 1/2" NPT conduit WS - Leadwire												
2 Size 20 - 20 size	6 Valve Housing Material A - Aluminum	9 Voltage Rating 12D - 12VDC 24D - 24VDC 120A - 120VAC 240A - 240VAC	11 Special Features 00 - None (Only required if valve has special features, omitted if "00".)												
3 Seals Blank - Buna N V - Viton® <small>Viton is a registered trademark of E.I. DuPont</small>	7 Port Size	<table border="1"> <thead> <tr> <th>CODE</th> <th>PT</th> <th>GAUGE</th> <th>HOUSING</th> </tr> </thead> <tbody> <tr> <td>12G</td> <td>1 1/4" BSPP</td> <td>1/4 BSPP</td> <td>02-178312</td> </tr> <tr> <td>20T</td> <td>SAE 20</td> <td>SAE #4</td> <td>02-178313</td> </tr> </tbody> </table>		CODE	PT	GAUGE	HOUSING	12G	1 1/4" BSPP	1/4 BSPP	02-178312	20T	SAE 20	SAE #4	02-178313
CODE	PT	GAUGE	HOUSING												
12G	1 1/4" BSPP	1/4 BSPP	02-178312												
20T	SAE 20	SAE #4	02-178313												
4 Type C - Normally closed O - Normally open															

COMPOSITION CHART

Cartridge	Description	Quantity
SV4-8-0-0-**-**	2 way/2 position N.O. poppet solenoid valve	1
SV4-8-C-0-**-**	2 way/2 position N.C. poppet solenoid valve	1
RV8-8-*0-**-**	Relief valve	1
DPS2-20-V-F-0-80	Differential pressure sensing valve	1

Pressure Drop Curve (unloading)

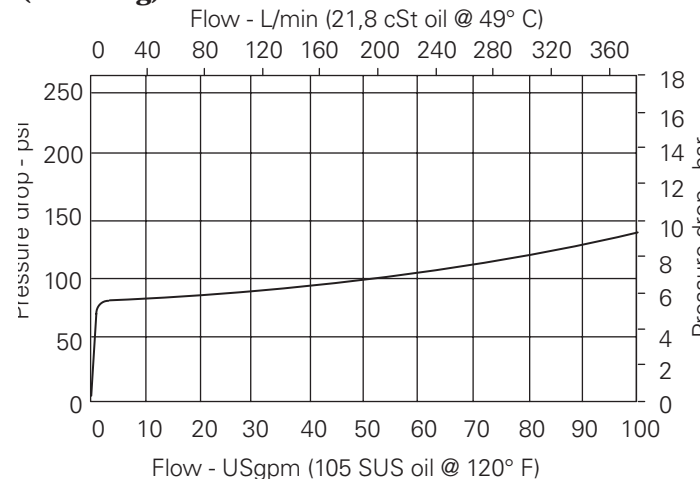

Pressure Override Curves

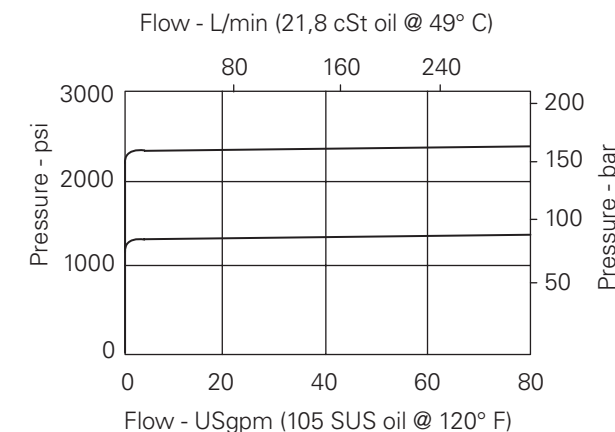

— P/V models

Description

Cross port relief valve

Functional Symbol

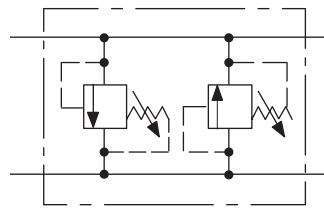

Features

- Tamper proof and adjustable relief options
- Aluminum in-line type housing
- All components in the package are true cartridges and can be removed from the housing without disturbing the plumbing

Application

This standard valve package is used to provide pressure relief for bi-directional motors and cylinders.

RATINGS AND SPECIFICATIONS

Typical application pressure	17 - 210 bar (250 - 3000 psi)
Flow rating	76 L/min (20 USgpm)
Reseat pressure	90% of crack pressure
Temperature range	-40° to 120° C (-40° to 248° F)
Fluids	All general purpose hydraulic fluids such as MIL-H-5606, SAE 10, SAE 20, etc.

Dimensions

mm (inch)

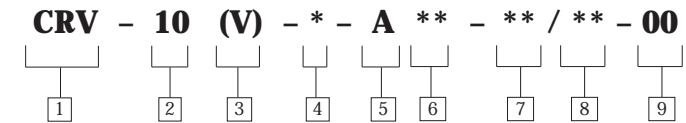
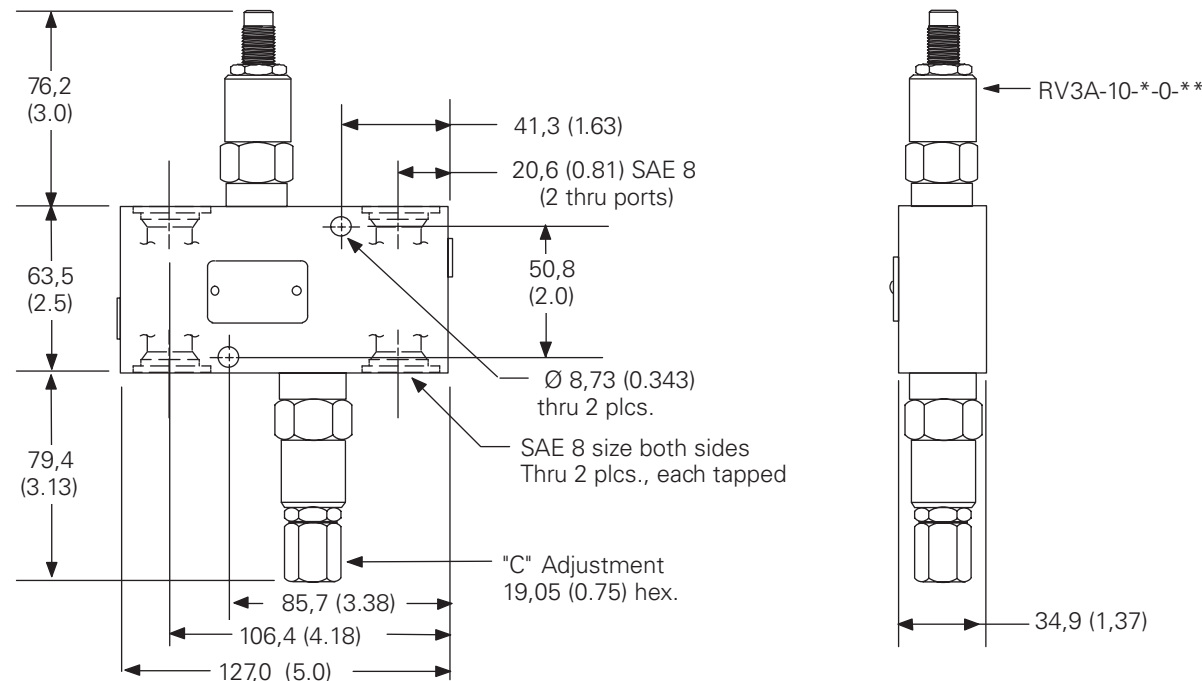

1 Function

CRV - Cross-port relief valve

2 Size

10 - 10 size

3 Seals

Blank - Buna N
V - Viton®

Viton is a registered trademark of E.I. DuPont

4 Relief Control

C - Cap
K - Knob
S - Screw

5 Valve Housing Material

A - Aluminum

6 Port Size

CODE	PORT SIZE	HOUSING NUMBER
3G	3/8" BSPP	02-178476
8T	SAE 8	889185

7 Pressure range

6 - 6 - 40 bar (100-600psi)
36 - 40 - 250 bar (600-3600psi)

8 Pressure setting - user requested in 50 PSI steps

example
10 - 1000psi
10.5 - 1050psi

9 Special Features

00 - None
(Only required if valve has special features, omitted if "00")

COMPOSITION CHART

Cartridge	Description	Quantity
RV3A-10-*0-**	Relief valve	2

Pressure Override Curve

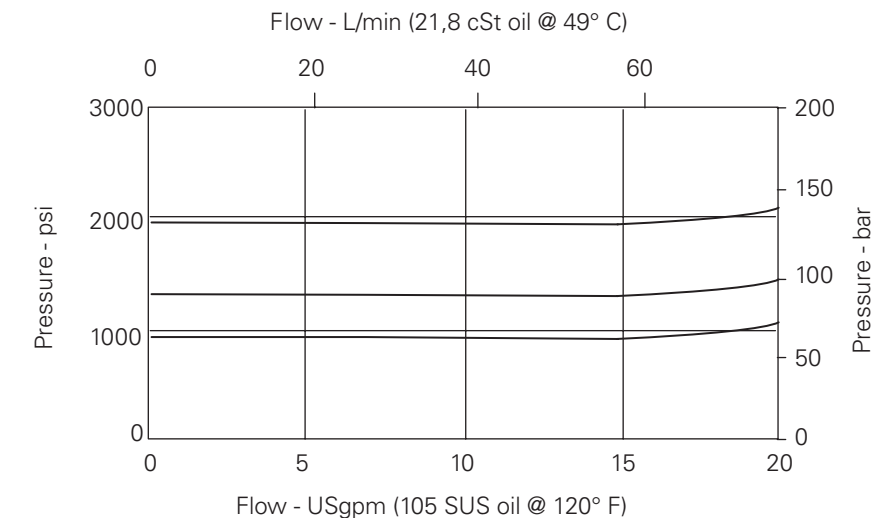

Description

Cross port relief valve

Functional Symbol

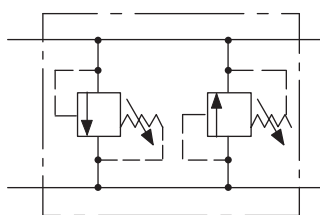

Features

- Tamper proof and adjustable relief options
- Aluminum in-line type housing
- All components in the package are true cartridges and can be removed from the housing without disturbing the plumbing

Application

This standard valve package is used to provide pressure relief for bi-directional motors and cylinders.

RATINGS AND SPECIFICATIONS

Typical application pressure	17 - 172 bar (250 - 3500 psi)
Flow rating	303 L/min (80 USgpm)
Reseat pressure	90% of crack pressure
Temperature range	-40° to 120° C (-40° to 248° F)
Fluids	All general purpose hydraulic fluids such as: MIL-H-5606, SAE 10, SAE 20, etc.

Dimensions

mm (inch)

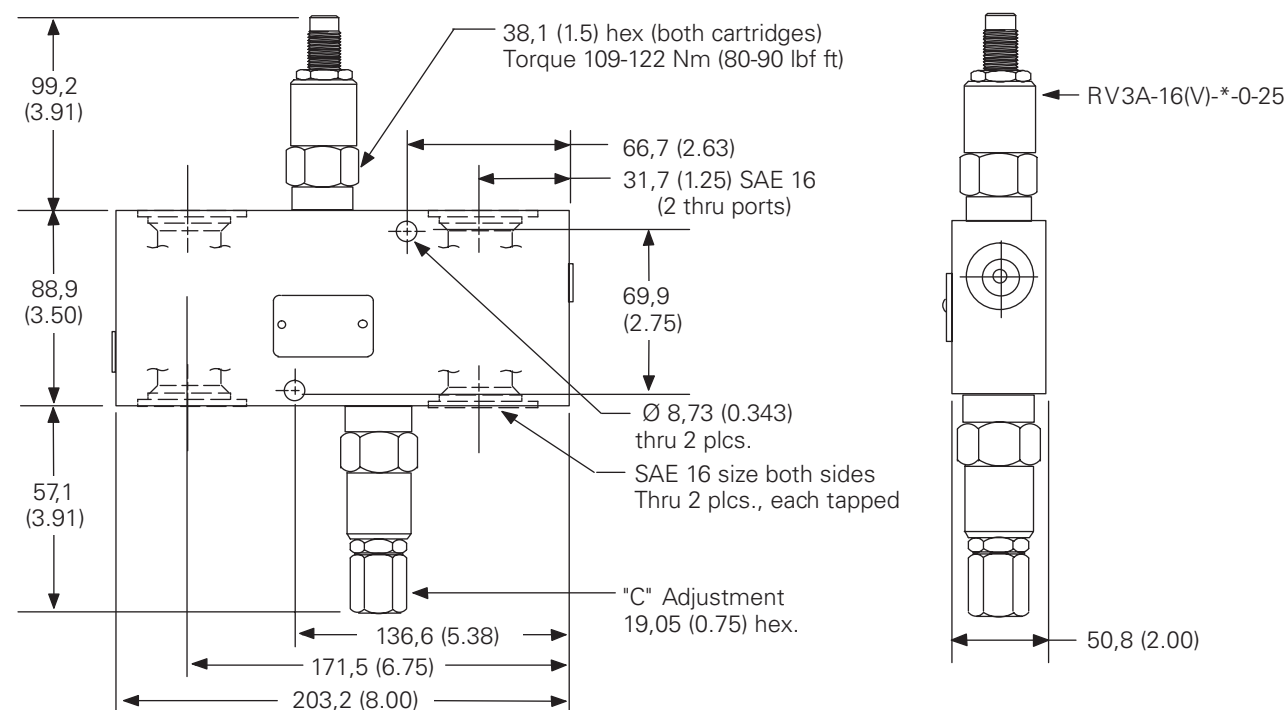

CRV - 16 (V) - * - A * - ** / ** - 00**



1 Function

CRV - Cross-port relief valve

2 Size

16 - 16 size

3 Seals

Blank - Buna-N
V - Viton®

Viton is a registered trademark of E.I. DuPont

4 Relief Control

C - Cap
K - Knob
S - Screw

5 Valve Housing Material

A - Aluminum

6 Port Size

CODE	PORT SIZE	HOUSING NUMBER
8G	1" BSPP	02-178477
16T	SAE 16	889189

7 Pressure range

35 - 17 - 175 bar (250-3500psi)

8 Pressure setting - user requested in 50 PSI steps
example
10 - 1000psi
10.5 - 1050psi

9 Special Features

00 - None
(Only required if valve has special features, omitted if "00")

COMPOSITION CHART

Cartridge	Description	Quantity
RV3A-16-*0-**	Relief valve	2

Pressure Override Curve

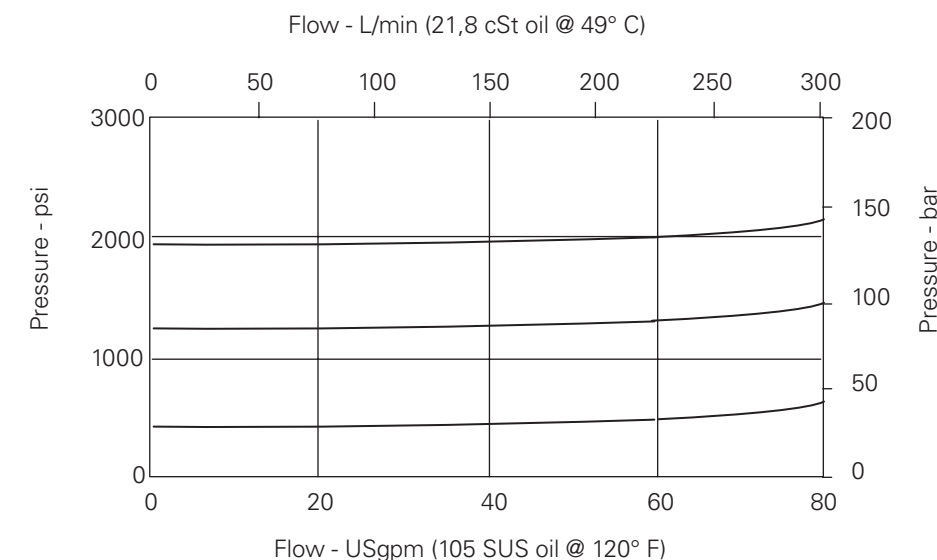

Description

Pressure sensitive regenerative valve package

Functional Symbol

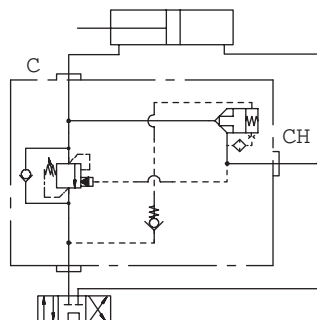

Features

- Automatic kick out of regenerative operation made via load pressure sensing.
- Tamper proof and adjustable pressure setting options.
- Provides a smooth transition and decrease of the regenerative flow through use of a counterbalance valve.
- Aluminum in-line type housing

Application

This standard valve package provides means for fast extension of a cylinder at low pressure without additional pump flow. This package diverts rod end flow to the head end in order to accelerate the load. When the load induced pressure reaches a predetermined level, the valve closes off. Rod end oil is automatically diverted to tank and the full pump pressure is applied, allowing maximum force to develop at lower speed.

When applying pressure sensitive regenerative valves consider the following:

- Rod to diameter ratio.
- The pressure required to move a cylinder.
- Losses due to high flows and seal friction may prevent a circuit from staying in regeneration.

RATINGS AND SPECIFICATIONS

Typical application pressure	210 bar (3000 psi)
Maximum regenerative flow 57 L/min (15 USgpm)	
Regeneration diminishes progressively above setting of CBV1-10.	
Temperature range	-40° to 120° C (-40° to 248° F)

Note: Regeneration circuits apply only to single rod cylinders in extension direction.

Dimensions

mm (inch)

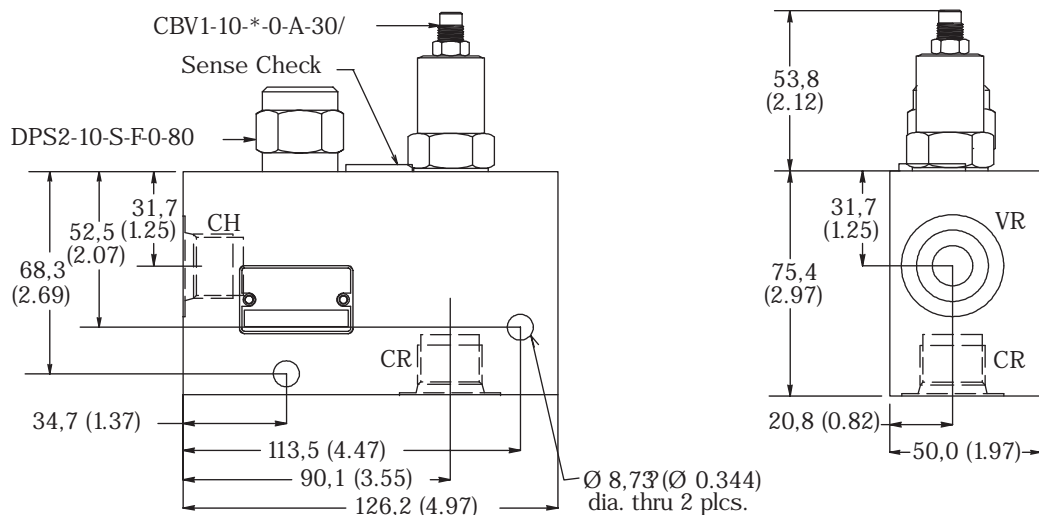

Note
This valve package should not be used as a load holding or load lowering control valve.

RGV - 10 (V) - * - A * - ** / ** - 00**

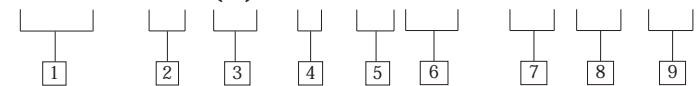

1 Function

RGV - Pressure sensitive regeneration valve

2 Size

10 - 10 size

3 Seals

Blank - Buna N
V - Viton®
Viton is a registered trademark of E.I. DuPont

4 Relief Control

C - Cap
K - Knob
S - Screw

5 Valve Housing Material

A - Aluminum

6 Port Size

CODE	PORT SIZE	HOUSING NUMBER
4G	1/2" BSPP	02-178930
10T	SAE 10	02-178929

7 Pressure range*

30 - 60 - 210 bar (900-3000psi)
* System pressure is limited to 210 bar (3000)psi

8 Pressure setting - user requested in 50 PSI steps

example
10 - 1000psi
10.5 - 1050psi

9 Special Features

00 - None
(Only required if valve has special features, omitted if "00")

COMPOSITION CHART

Cartridge	Description	Quantity
CBV1-10-*-0-A-30/	Counterbalance valve	1
DPS2-10-S-F-0-80	Differential pressure sensing	1
566395	Sense check kit	1

Application Notes

Formulas to calculate flow in regeneration circuits are:
(Where Db = Bore Diameter and Dr = Rod Diameter)

$$\text{Combined Flow (pump flow plus regenerative flow)} = \frac{Db^2}{Dr^2} \times \text{Pump Flow}$$

$$\text{Regenerative Flow (flow out rod end)} = \frac{Db^2 - Dr^2}{Dr^2} \times \text{Pump Flow}$$

$$\text{Retraction Flow (flow out of the bind end during retraction)} = \frac{Db^2}{Db^2 - Dr^2} \times \text{Pump Flow}$$

Pressure Drop Curve

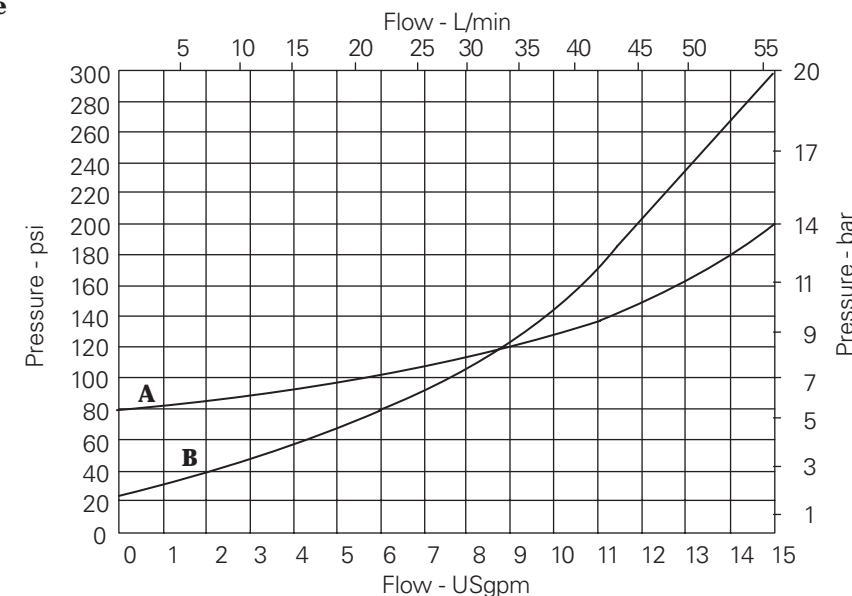

A - Port CR to CH
B - Port VR to CR

Description

Pressure sensitive regenerative valve package

Functional Symbol

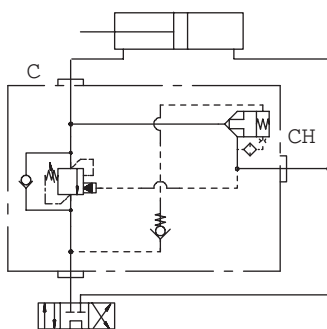

Features

- Automatic kick out of regenerative operation made via load pressure sensing.
- Tamper proof and adjustable pressure setting options.
- Provides a smooth transition and decrease of the regenerative flow through use of a counterbalance valve.
- Aluminum in-line type housing

Application

This standard valve package provides means for fast extension of a cylinder at low pressure without additional pump flow. This package diverts rod end flow to the head end in order to accelerate the load. When the load induced pressure reaches a predetermined level, the valve closes off. Rod end oil is automatically diverted to tank and the full pump pressure is applied, allowing maximum force to develop at lower speed.

When applying pressure sensitive regenerative valves consider the following:

- Rod to diameter ratio.
- The pressure required to move a cylinder.
- Losses due to high flows and seal friction may prevent a circuit from staying in regeneration.

RATINGS AND SPECIFICATIONS

Typical application pressure	210 bar (3000 psi)
Maximum regenerative flow 114 L/min (30 USgpm) Regeneration diminishes progressively above setting of CBV1-12.	
Temperature range	-40° to 120° C (-40° to 248° F)
Note: Regeneration circuits apply only to single rod cylinders in extension direction.	

Dimensions

mm (inch)

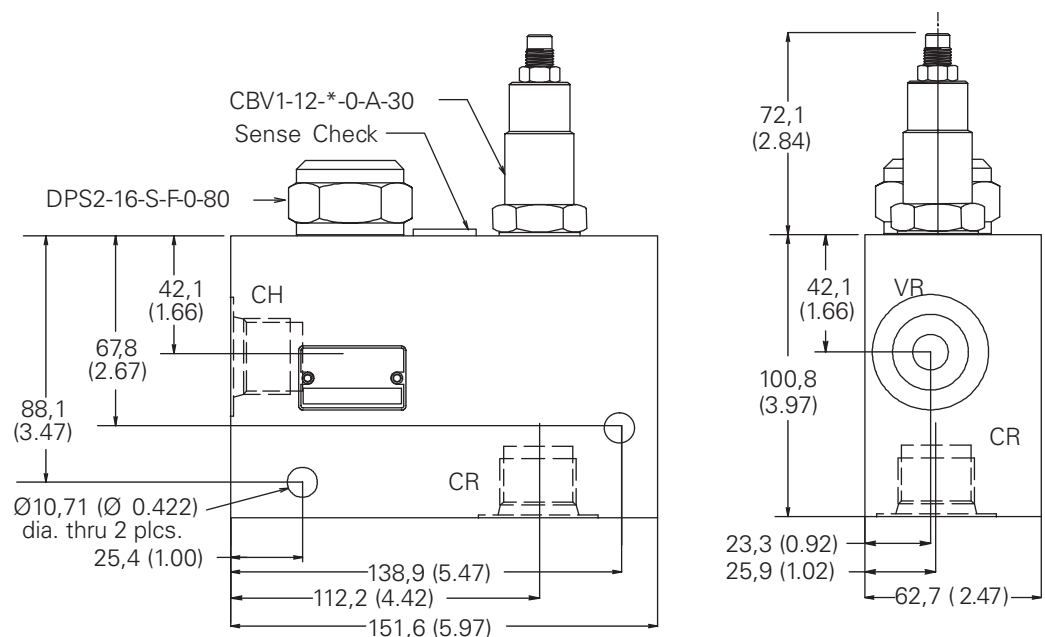

Note
This valve package should not be used as a load holding or load lowering control valve.

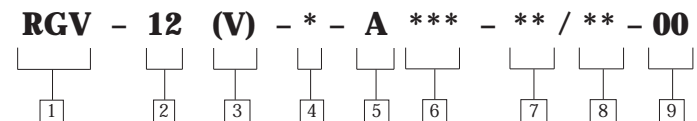

1 Function

RGV - Pressure sensitive regeneration valve

2 Size

12 - 12 size

3 Seals

Blank - Buna N
V - Viton®
Viton is a registered trademark of E.I. DuPont

4 Relief Control

C - Cap
K - Knob
S - Screw

5 Valve Housing Material

A - Aluminum

6 Port Size

CODE	PORT SIZE	HOUSING NUMBER
6G	3/4" BSPP	02-178932
12T	SAE 12	02-178931

7 Pressure range*

30 - 60 - 210 bar (900-3000psi)
* System pressure is limited to 210 bar (3000)psi

8 Pressure setting - user requested in 50 PSI steps example
10 - 1000psi
10.5 - 1050psi

9 Special Features

00 - None
(Only required if valve has special features, omitted if "00")

COMPOSITION CHART

Cartridge	Description	Quantity
CBV1-12-*0-A-30/	Counterbalance valve	1
DPS2-16-S-F-0-80	Differential pressure sensing	1
566395	Sense check kit	1

Application Notes

Formulas to calculate flow in regeneration circuits are:
(Where Db = Bore Diameter and Dr = Rod Diameter)

$$\text{Combined Flow (pump flow plus regenerative flow)} = \frac{Db^2}{Dr^2} \times \text{Pump Flow}$$

$$\text{Regenerative Flow (flow out rod end)} = \frac{Db^2 - Dr^2}{Dr^2} \times \text{Pump Flow}$$

$$\text{Retraction Flow (flow out of the bind end during retraction)} = \frac{Db^2}{Db^2 - Dr^2} \times \text{Pump Flow}$$

Pressure Drop Curves

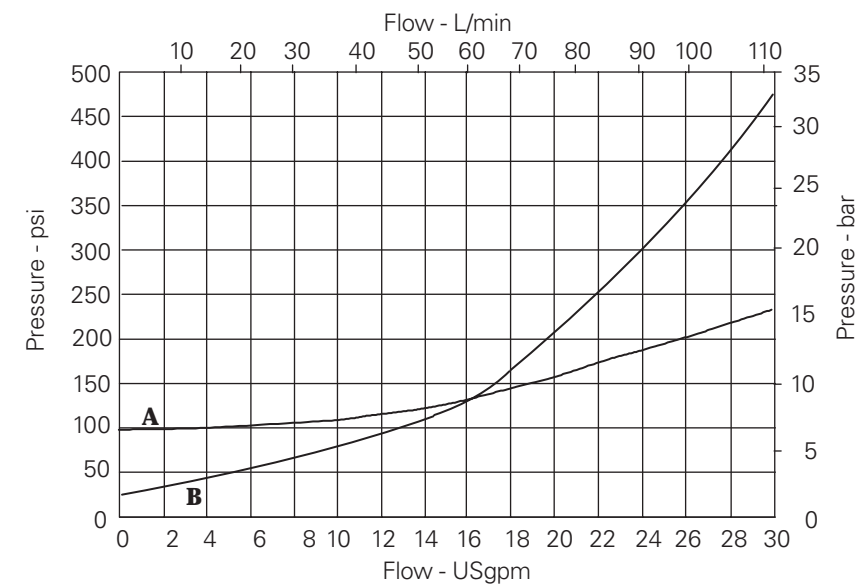

A - Port CR to CH
B - Port VR to CR

Description

Pressure sensitive regenerative valve package with load locking

Functional Symbol

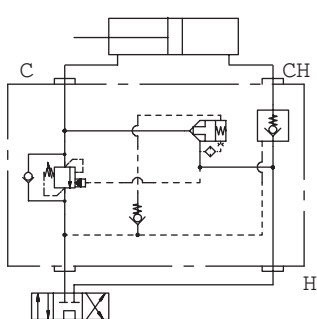

Features

- Automatic kick out of regenerative operation made via load pressure sensing.
- Tamper proof and adjustable pressure setting options.
- Provides a smooth transition and decrease of the regenerative flow through use of a counterbalance valve.
- Provides manual override on POC cartridge to lower the load in the event of power loss
- Aluminum in-line type housing

Application

This standard valve package provides means for fast extension of a cylinder at low pressure without additional pump flow. This package diverts rod end flow to the head end in order to accelerate the load. When the load induced pressure reaches a predetermined level, the valve closes off. Rod end oil is automatically diverted to tank and the full pump pressure is applied, allowing maximum force to develop at lower speed.

When applying pressure sensitive regenerative

valves consider the following:

- Rod to diameter ratio.
- The pressure required to move a cylinder.
- Losses due to high flows and seal friction may prevent a circuit from staying in regeneration.

RATINGS AND SPECIFICATIONS

Typical application pressure 210 bar (3000 psi)

Maximum regenerative flow 57 L/min (15 USgpm)
Regeneration diminishes progressively above setting of CBV1-10.

Temperature range -40° to 120° C (-40° to 248° F)

Note: Regeneration circuits apply only to single rod cylinders in extension direction.

Dimensions

mm (inch)

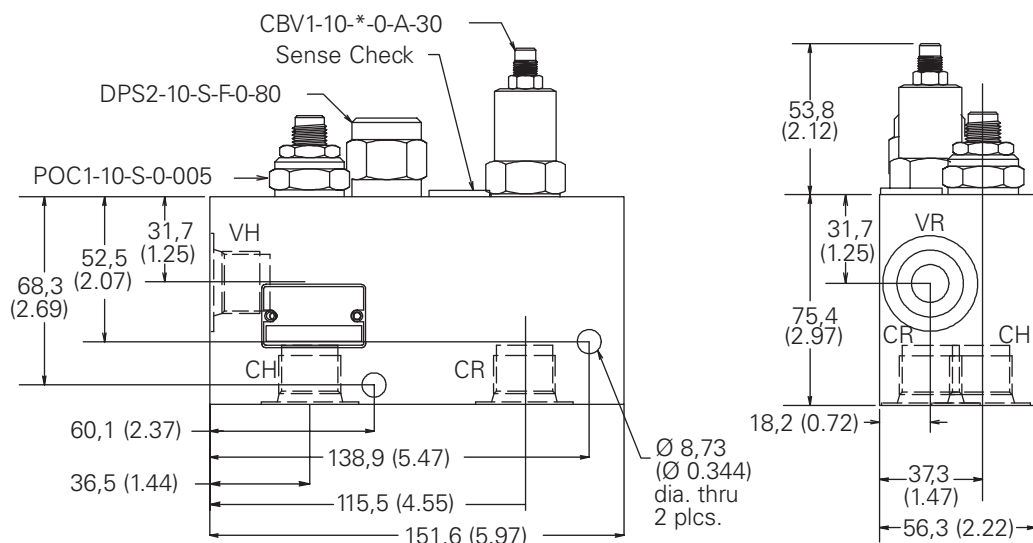

Note
This valve package should not be used as a load holding or load lowering control valve.

RLV - 10 (V) - * - A * - ** / ** - 00**

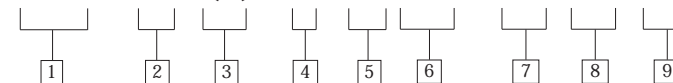

1 Function

RLV - Pressure sensitive regeneration valve w/ load holding check valve

2 Size

10 - 10 size

3 Seals

Blank - Buna N
V - Viton®
Viton is a registered trademark of E.I. DuPont

4 Relief Control

C - Cap
K - Knob
S - Screw

5 Valve Housing Material

A - Aluminum

6 Port Size

CODE	PORT SIZE	HOUSING NUMBER
4G	1/2" BSPP	02-178934
10T	SAE 10	02-178933

7 Pressure range*

30 - 60 - 210 bar (900-3000psi)
* System pressure is limited to 210 bar (3000)psi

8 Pressure setting - user

requested in 50 PSI steps
example
10 - 1000psi
10.5 - 1050psi

9 Special Features

00 - None
(Only required if valve has special features, omitted if "00")

COMPOSITION CHART

Cartridge	Description	Quantity
CBV1-10-*0-A-30/	Counterbalance valve	1
DPS2-10-S-F-0-80	Differential pressure sensing	1
POC1-10-S-0-005	Pilot operated check valve	1
566395	Sense check kit	1

Application Notes

Formulas to calculate flow in regeneration circuits are:
(Where Db = Bore Diameter and Dr = Rod Diameter)

$$\text{Combined Flow (pump flow plus regenerative flow)} = \frac{Db^2}{Dr^2} \times \text{Pump Flow}$$

$$\text{Regenerative Flow (flow out rod end)} = \frac{Db^2 - Dr^2}{Dr^2} \times \text{Pump Flow}$$

$$\text{Retraction Flow (flow out of the bind end during retraction)} = \frac{Db^2}{Db^2 - Dr^2} \times \text{Pump Flow}$$

Pressure Drop Curves

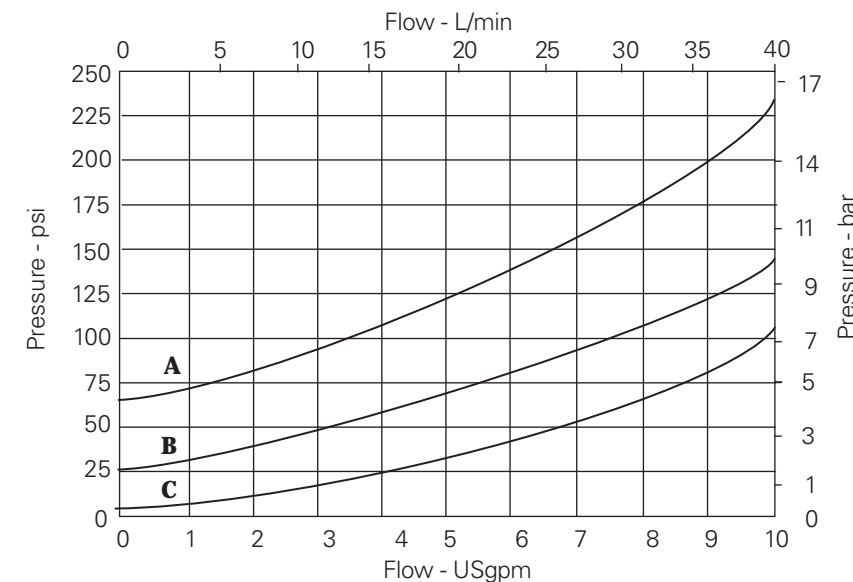

A - Port CR to CH
B - Port VR to CR
C - Port VH to CH

Description

Pressure sensitive regenerative valve package with load locking

Functional Symbol

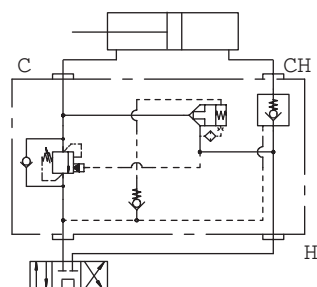

Features

- Automatic kick out of regenerative operation made via load pressure sensing.
- Tamper proof and adjustable pressure setting options.
- Provides a smooth transition and decrease of the regenerative flow through use of a counterbalance valve.
- Provides manual override on POC cartridge to lower the load in the event of power loss
- Aluminum in-line type housing

Application

This standard valve package provides means for fast extension of a cylinder at low pressure without additional pump flow. This package diverts rod end flow to the head end in order to accelerate the load. When the load induced pressure reaches a predetermined level, the valve closes off. Rod end oil is automatically diverted to tank and the full pump pressure is applied, allowing maximum force to develop at lower speed. When applying pressure sensitive regenerative

valves consider the following:

- Rod to diameter ratio.
- The pressure required to move a cylinder.
- Losses due to high flows and seal friction may prevent a circuit from staying in regeneration.

RATINGS AND SPECIFICATIONS

Typical application pressure	210 bar (3000 psi)
Maximum regenerative flow 114 L/min (30 USgpm) Regeneration diminishes progressively above setting of CBV1-12.	
Temperature range	-40° to 120° C (-40° to 248° F)

Note: Regeneration circuits apply only to single rod cylinders in extension direction.

Dimensions

mm (inch)

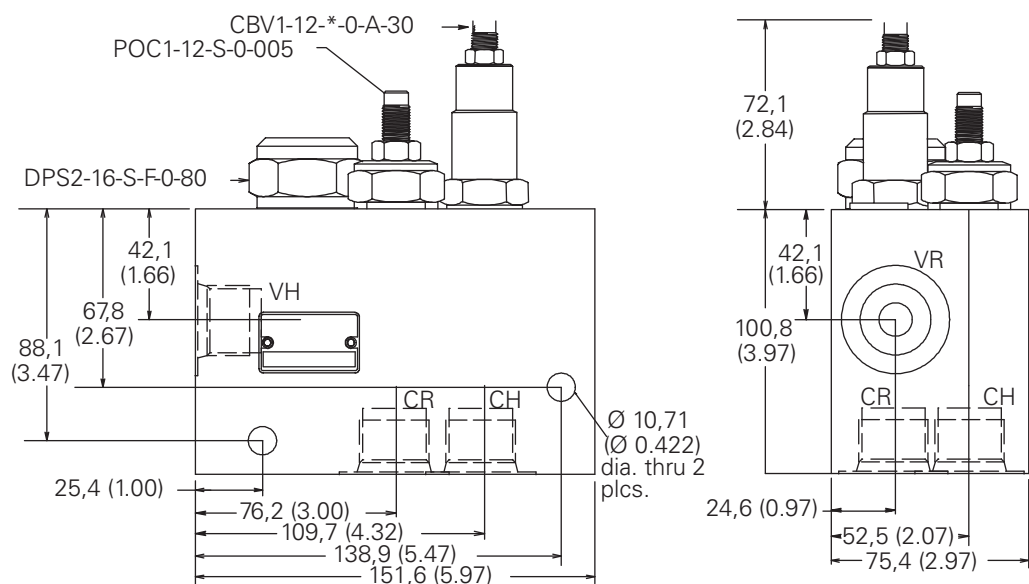

Note
This valve package should not be used as a load holding or load lowering control valve.

RLV - 12 (V) - * - A * - ** / ** - 00**

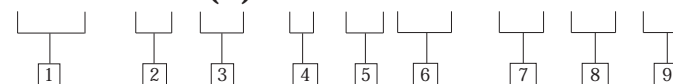

1 Function

RLV - Pressure sensitive regeneration valve w/ load holding check valve

2 Size

12 - 12 size

3 Seals

Blank - Buna N
V - Viton®

Viton is a registered trademark of E.I. DuPont

4 Relief Control

C - Cap
K - Knob
S - Screw

5 Valve Housing Material

A - Aluminum

6 Port Size

CODE	PORT SIZE	HOUSING NUMBER
6G	3/4" BSPP	02-178936
12T	SAE 12	02-178935

7 Pressure range*

30 - 60 - 210 bar (900-3000psi)
* System pressure is limited to 210 bar (3000)psi

8 Pressure setting - user requested in 50 PSI steps

example
10 - 1000psi
10.5 - 1050psi

9 Special Features

00 - None
(Only required if valve has special features, omitted if "00")

COMPOSITION CHART

Cartridge	Description	Quantity
CBV1-12-*0-A-30/	Counterbalance valve	1
DPS2-16-S-F-0-80	Differential pressure sensing	1
POC1-12-S-0-005	Pilot operated check valve	1
566395	Sense check kit	1

Application Notes

Formulas to calculate flow in regeneration circuits are:
(Where Db = Bore Diameter and Dr = Rod Diameter)

$$\text{Combined Flow (pump flow plus regenerative flow)} = \frac{Db^2}{Dr^2} \times \text{Pump Flow}$$

$$\text{Regenerative Flow (flow out rod end)} = \frac{Db^2 - Dr^2}{Dr^2} \times \text{Pump Flow}$$

$$\text{Retraction Flow (flow out of the bind end during retraction)} = \frac{Db^2}{Db^2 - Dr^2} \times \text{Pump Flow}$$

Pressure Drop Curves

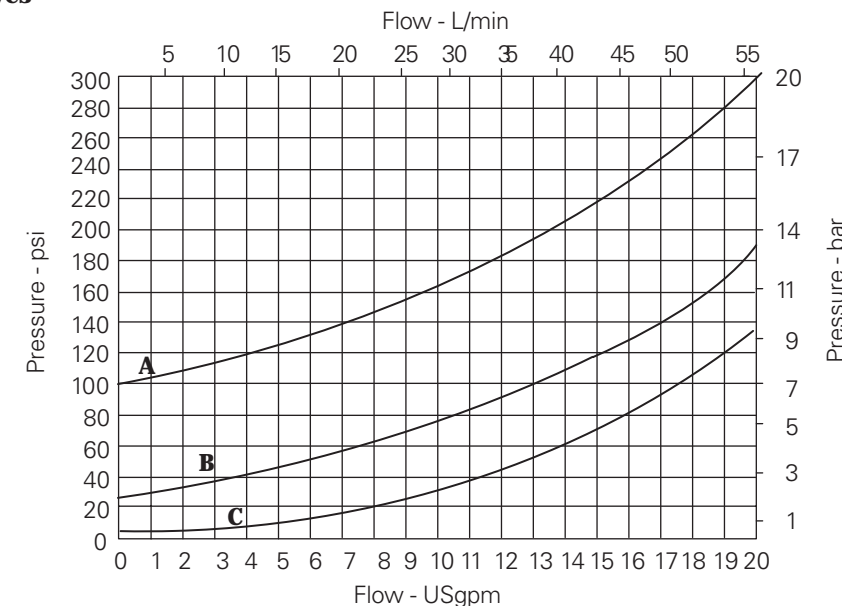

A - Port CR to CH
B - Port VR to CR
C - Port VH to CH

Description

Cross port relief with shuttle and solenoid vent

Functional Symbol

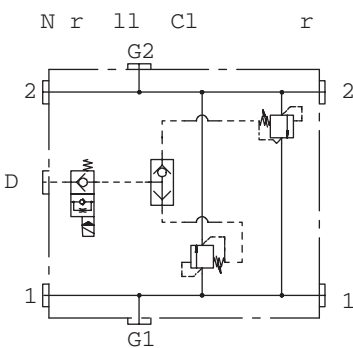
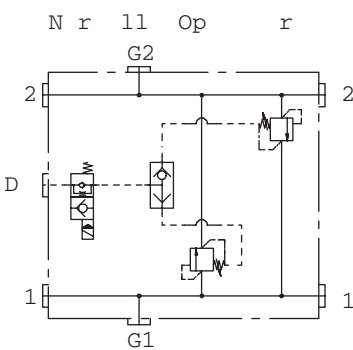

Dimensions

mm (inch)

Features

- Normally closed and normally open options.
- Tamper proof or adjustable relief options
- Gauge port.
- Low power requirements.
- Number of voltages and connectors options.
- Aluminum in line type housing.
- All components in the package are true cartridges and can be removed from the housing without disturbing the plumbing.

Application

This standard valve package is used to provide pressure line relief for bi-directional motors and cylinders. With the addition of a remotely controlled shuttle valve, allowance is made for motor slip or cylinder dump conditions.

RATINGS AND SPECIFICATIONS

Typical application pressure	210 bar (3000 psi)
Flow rating	114 L/min (30 USgpm)
Reset pressure	90% of crack pressure
Coil specifications	
Power requirements – 16 watts Magnet wire – UL class N rated (200 C)	
Coil duty – continuous from 85% to 110% of nominal voltage	
AC coils are internally rectified	
Temperature range	-40° to 120° C (-40° to 248° F)

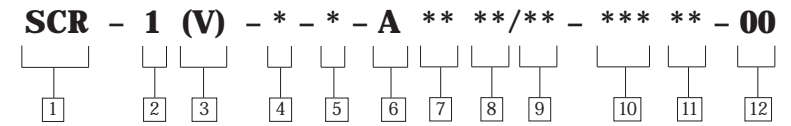
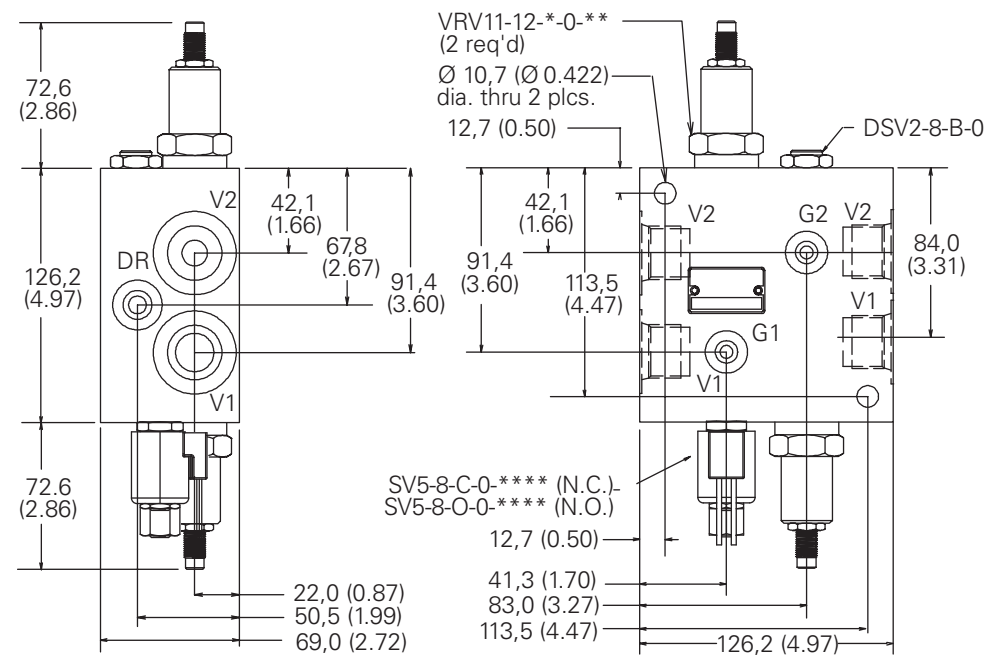

1 Function

SCR - Solenoid actuated crossover relief valve with shuttle

2 Size

1 - 114 L/min (30 USgpm)

3 Seals

Blank - Buna N
V - Viton®
 Viton is a registered trademark of E.I. DuPont

4 Type

C - Normally closed
O - Normally open

5 Relief Control

C - Cap
K - Knob
S - Screw

6 Valve Housing Material

A - Aluminum

7 Port Size

CODE	V1, V2	GAUGE	DRAIN	HOUSING NUMBER
6G	3/4" BSPP	1/4" BSPP	3/8" BSPP	02-178938
12T	SAE 12	SAE 4	SAE 6	02-178937

8 Pressure range*

15 - 5 - 100 bar (75-1500psi)
30 - 10 - 210 bar (150-3000psi)
 * **System pressure is limited to 210 bar (3000)psi**

9 Pressure setting

- user requested in 50 PSI steps example
10 - 1000psi
10.5 - 1050psi

10 Voltage Rating

12D - 12VDC
24D - 24VDC
120A - 120VAC
240A - 240VAC

11 Connector types

GS - ISO 4400 DIN 43650 connector
PS - 1/2" NPT conduit
WS - Leadwire

12 Special Features

00 - None
 (Only required if valve has special features, omitted if "00".)

COMPOSITION CHART

Cartridge	Description	Catalog	Quantity
VRV11-12-*0-**/	Ventable relief valve	725	2
DSV2-8-B-0	Shuttle valve	721	1
SV5-8-C-0-**	Solenoid valve, N.C.	727	1
SV5-8-O-0-**	Solenoid valve, N.O.	727	1

Pressure Drop Curves

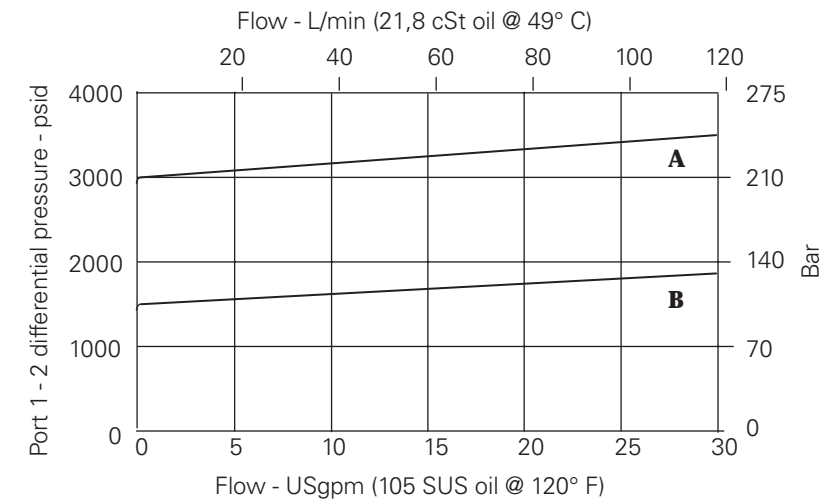

A - 30 - pressure range code
B - 15 - pressure range code

Description

Unloading valve

Features

- XXXXXXXXXXXXXXXXXXXX

Application

XXXXXXXXXXXXXXXXXXXXXXXXX
XXXXXXXXXXXXXXXXXXXXXXXXX

Functional Symbol

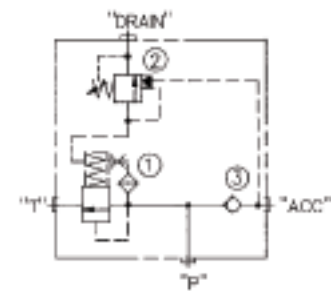

RATINGS AND SPECIFICATIONS

Typical application pressure	210 bar (3000 psi)
Flow rating	Up to 57 L/min (15 USgpm)
Temperature range	-40° to 120° C (-40° to 248° F)
Fluids	All general purpose hydraulic fluids such as: MIL-H-5606, SAE 10, SAE 20, etc.

Dimensions

mm (inch)

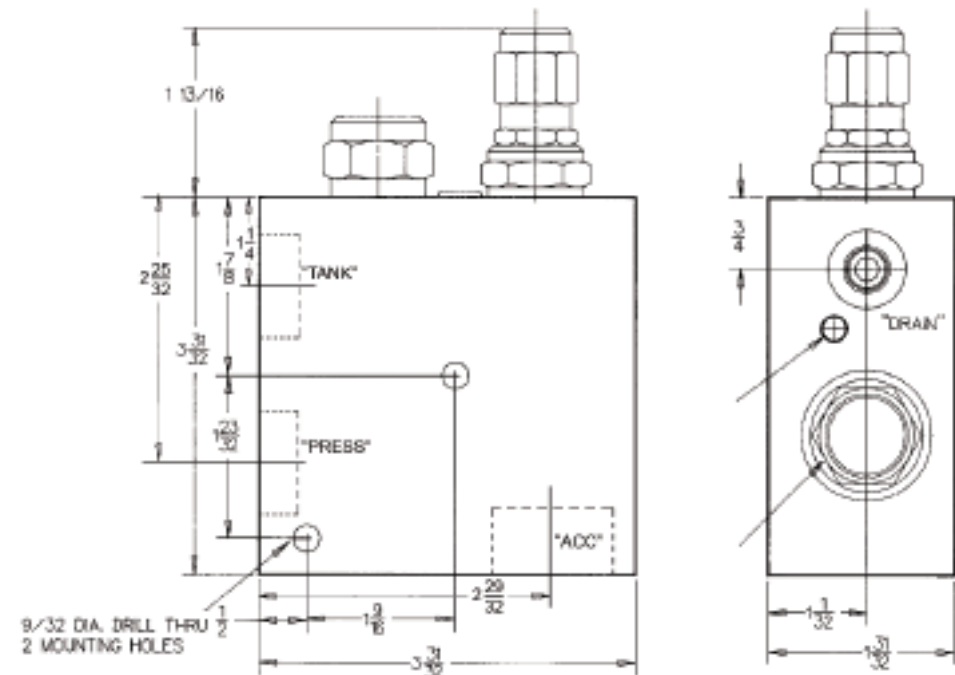

UV2 - 10 (V) - 8T - ** - ** - **

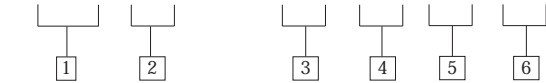

1 Function

UV2 - Unlodng valve

3 Ports

8T - SAE - 8

6 Pressure Setting (optional)

Specified by customer in 50 psi increments) for example :
20 - 140 bar (2000 psi)
25 - 172 bar (2500 psi)

2 Size & Seals

10 - Buna N
10V - Viton®

4 Load Ratio

90 = 90%
85 = 85%
80 = 80%
75 = 75%

Viton is a registered trademark of E.I. DuPont

5 Pressure Range

15 300-1500 psi
30 1500-3000 psi

COMPOSITION CHART

Cartridge	Description	Catalog	Quantity
CV1-10X-P-0-5	Poppet type check vane	G-8	1
DPS2-10X-V-F-0-80	Differetial pressure sensing valve	I-18	1
PUV3-10X-XX-XX/XX	Pilot unloading valve	E-70	1