



Flow Controls

Flow control functions for applications up to 350 bar (5000 psi)
and 570 L/min (150 gpm)



F

Section contents

Model	Typical Application Pressure bar (psi)	Rated Flow L/min (USgpm)	Page
Flow control cartridges - Introduction, features and benefits.....			F-3
Flow regulator valves, fixed, pressure compensated			
FR5-8	350 (5000)	10 (2.5)	F-4
FR5-10	350 (5000)	23 (6)	F-6
FR1-16.....	210 (3000)	114 (30).....	F-8
FR1-20	210 (3000)	227 (60)	F-10
Flow regulator valves, adjustable, pressure compensated			
FR2-10	210 (3000)	38 (10)	F-12
FR2-16	210 (3000)	114 (30).....	F-14
FAR1-10	350 (5000)	38 (10)	F-16
FAR1-12.....	350 (5000)	95 (25).....	F-18
FAR1-16.....	350 (5000)	114 (30).....	F-20
Priority flow regulators (bypass type, fixed)			
PFR5-8	350 (5000)	15 (4)	F-22
PFR5-10	350 (5000)	60 (15)	F-24
PFR1-16	210 (3000)	151 (40)	F-26
Priority flow regulators (bypass type, adjustable)			
PFR2-10	210 (3000)	60 (15)	F-28
PFR2-16.....	210 (3000)	151 (40)	F-30
Static and dynamic signal priority valves (for steering circuits)			
PFR*-12	280 (4000)	76 (20)	F-32
PFR*-16	280 (4000)	150 (40)	F-34
PFR*-20	280 (4000)	230 (60)	F-36
Manual rotary flow control cartridges			
MRV2-10.....	210 (3000)	19-57 (5-15)	F-38
MRV2-16.....	210 (3000)	38-170 (10-45).....	F-40
Needle valve cartridges			
NV1-8	350 (5000)	45 (12)	F-42
NV1-10	210 (3000)	45 (12)	F-44
NV1-16	210 (3000)	151 (40)	F-46
NV1-20.....	210 (3000)	265 (70)	F-48
Flow control cartridges			
FCV7-10	210 (3000)	45 (12)	F-50
FCV11-12.....	350 (5000)	114 (30).....	F-52
FCV6-16	210 (3000)	208 (55).....	F-54
Velocity fuse cartridges			
VF11-10	350 (5000)	23 (6)	F-56
VF1-16.....	210 (3000)	114 (30).....	F-58
VF1-20.....	210 (3000)	227 (60)	F-60
Flow divider/combiner cartridges and manifold assemblies			
FDC1-10	210 (3000)	6-61 (1.5-16).....	F-62
FDC11-10	350 (5000)	9.5-38 (2.5-10)	F-64
FDC1-16.....	210 (3000)	46-178 (12-47)	F-66
FDC11-16	350 (5000)	84-152 (22-40)	F-68
FDC1-20.....	210 (3000)	190-380 (50-100)	F-70
Posi-traction cartridges and manifold assemblies			
FDC3-10.....	210 (3000)	23-61 (6-16)	F-72
FDC13-10	350 (5000)	19-38 (5-10)	F-74
FDC3-16.....	210 (3000)	57-228 (15-60).....	F-76
FDC13-16.....	350 (5000)	57-152 (15-40).....	F-78
FDC3-20.....	210 (3000)	190-570 (50-150)	F-80

Flow Controls

Section introduction

This section gives basic specifications for the complete line of Vickers threaded cartridge flow control valves. Its purpose is to provide a quick, convenient reference tool when choosing Vickers cartridge valves or designing a system using these components.

Valve Features and Benefits

Eaton offers a complete range of Vickers flow controls cartridge valves, with a variety of features, including:

- Products in this catalog have been Fatigue tested to one million cycles at 132% or 10 million cycles at 115% of rated pressure.
- Non-adjustable, pressure compensated, flow regulator for flows to 227 L/min (60 USgpm).
- Adjustable, pressure compensated, flow regulator for flows to 114 L/min (30 USgpm).
- Fixed and adjustable priority bypass type flow regulator for regulated flows to 114 L/min (30 USgpm).
- Adjustable flow control without free reverse flow check with flows rated to 114 L/min (30 gpm).
- Adjustable flow control with free reverse flow check with flows rated to 45 L/min (12 gpm).
- Needle valves with flows rated to 265 L/min (70 USgpm).
- Velocity fuses with flows rated to 227 L/min (60 USgpm).

- Flow divider/combiners (FDC1 and FDC11) with flows rated to 568 L/min (150 USgpm).
- Posi-traction valves (FDC13) with flows rated to 567 L/min (150 USgpm)
- Operating pressures to 350 bar (5000 psi).

Here are some of the benefits of Vickers flow controls:

- All operating parts are hardened steel, ground and honed for long life and low leakage.
- Designed for maximum flexibility and minimal space requirements.
- All exposed cartridge surfaces are zinc dichromate plated to resist corrosion. Steel housings are available for cartridges rated to 350 bar (5000 psi) application pressures.
- All aluminum manifolds are gold anodized to resist corrosion.
- Reliable, economical and compact.
- Low leakage.
- Variety of adjustment options.
- Adjustments designed not to go spring solid at "full in" position or to allow the adjustment to be removed when backed out.

Notable are the two styles of flow divider/combiner:

FDC1/FDC11

The FDC*1 is a cartridge type hydraulic flow divider-combiner valve. It divides and combines flow, regardless of system load or pressure, proportionally per specified flow division.

For example: FDC*1-10-*–66 will divide an incoming flow of 45 L/min (12 USgpm) equally out each port with an accuracy of 10% each side. With 45 L/min (12 USgpm) in at "3" port, flow out port "4" can be 22 L/min (6 USgpm) 4,5 L/min (1.2 USgpm) while flow at port "2" is 22,7 L/min (6 USgpm) 4,5 L/min (1.2 USgpm).

The combining accuracy is the same with incoming flow at port "4" and "2" and flow out port "3" of 45 L/min (12 USgpm). Inlet flow at port "4" will be 22 L/min (6 USgpm) 4,5 L/min (1.2 USgpm). Inlet flow at port "2" will be 22 L/min (6 USgpm) 4,5 L/min (1.2 USgpm).

Flow division or combining will be maintained even if unequal loads are placed on ports "4" and "2".

A special feature of the FDC*1-*** is that it provides rephase flow to either port 2 or port 4 when one of the two is blocked. This feature is useful in hydraulic circuits that require cylinders to move at the same time. If one cylinder bottoms out first, the opposite cylinder is provided with "rephase" flow to allow the cylinder to bottom and start the cylinders together for movement in the opposite direction.

FDC3/FDC13

The FDC*3 is a cartridge type positive traction valve that divides and combines flow, regardless of system load or pressure, proportionally per specified flow division.

This valve is used in place of a standard flow divider-combiner in systems where hydraulic motors are used as drive wheels on each side of the machine. The positive traction valve acts much like a standard flow divider-combiner as the vehicle travels in a straight line. Equal amounts of flow go to each "C" port. As the vehicle turns a corner, a standard flow divider will maintain equal flow to each drive motor. On a turn, it is necessary for the outer wheel to turn faster than the inner wheel. A standard flow divider-combiner will provide equal flow to each motor causing the drive motors to skid. The positive traction valve solves this problem by allowing the one motor to turn faster than the other.

This operates in a similar way as a mechanical differential on an automobile. In a turn, the inside drive motor is restricted and builds up pressure, while the outside drive motor is without restriction. Under conditions of high differential pressure, the positive traction valve passes extra flow to the least restricted motor to prevent skidding. Under straight running conditions the differential pressure is low and equal amounts of flow are provided to each drive motor.



WARNING

For pressure over 210 bar (3000 psi) use steel housing.

FR5-8

Flow regulator, fixed

Description

The FR5-8 is a fixed orifice, pressure compensated, restrictive flow regulator screw-in cartridge valve.

Operation

This valve maintains a constant flow from port 1 to port 2 based on 5.5 bar (80 psid) regardless of pressure changes downstream on

port 2. Reverse flow from port 2 to port 1 is at the value of the fixed orifice and is non-pressure compensated.

Functional Symbols

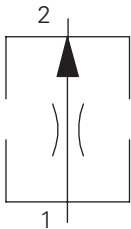

Sectional View

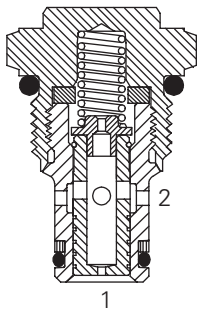

RATINGS AND SPECIFICATIONS

Performance data is typical with fluid at 21,8 cSt (105 SUS) and 49°C (120°F)

Typical application pressure (all ports)	350 bar (5000 psi) steel housing 210 bar (3000 psi) aluminum housing
Cartridge fatigue pressure (infinite life)	280 bar (4000 psi)
Rated flow	10 L/min (2.5 USgpm)
Flow regulation accuracy	0,4–1,9 L/min (0.1–0.49 USgpm) 20% @ 210 bar (3000 psi) 0,4–1,9 L/min (0.1–0.49 USgpm) 40% @ 350 bar (5000 psi) 1,9 – 5,7 L/min (0.5–1.49 USgpm) 15% 5,7–10 L/min (1.5–2.5 USgpm) 10%
<small>Factory set maximum flow rate accuracy under standard test conditions and within the above ranges</small>	
Temperature range	–40° to 120°C (–40° to 248°F)
Cavity	C–8–2
Fluids	All general purpose hydraulic fluids such as: MIL–H–5606, SAE 10, SAE 20, etc.
Filtration	Cleanliness code 18/16/13
Standard housing materials	Aluminum or steel
Weight cartridge only	0,05 kg (0.12 lbs.)
Seal kits	02–165875 Buna-N 02–165877 Viton®
<small>Viton is a registered trademark of E.I. DuPont</small>	

Typical Flow Regulation

Cartridge only

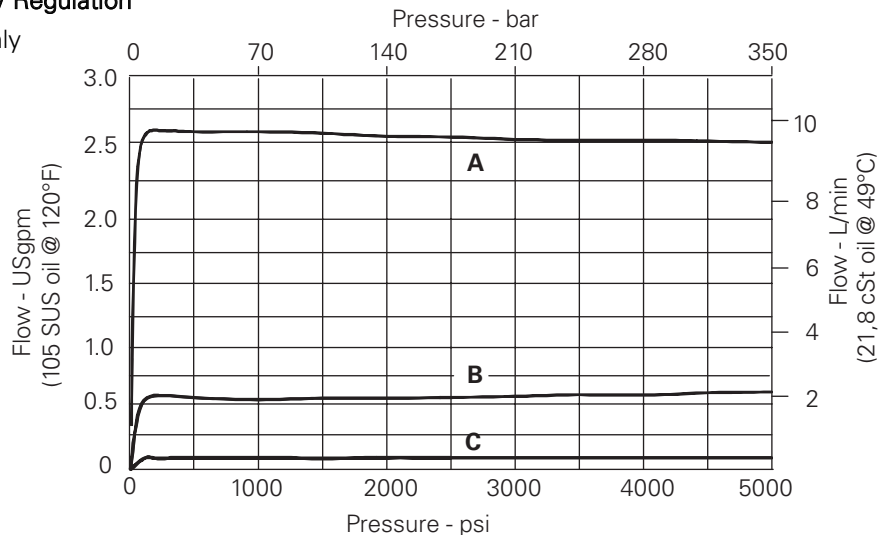

- A – 9,5 L/min (2.5 USgpm)
- B – 1,9 L/min (0.5 USgpm)
- C – 0,38 L/min (0.1 USgpm)

FR 5-8 (V)-F-(*) **-*. *-00

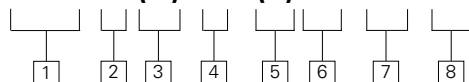

1 Function
FR5 – Flow regulator

2 Size
8 – 8 Size

3 Seals
Blank – Buna-N
V – Viton®

4 Adjustment
F – Fixed orifice

5 Valve housing material
Omit for cartridge only
S – Steel
A – Aluminum

6 Port size
0 – Cartridge only

CODE	PORT SIZE	HOUSING NUMBER	
		Aluminum Fatigue rated	Steel Fatigue rated
4T	SAE 4	02-160730	02-160736
6T	SAE 6	02-160731	02-160737
8T	SAE 8	02-160732	02-160738
2G	1/4" BSPP	02-160727	02-160733
3G	3/8" BSPP	02-160728	02-160734

See section J for housing details.

7 Factory set flow rate, nominal

(Specify in USgpm)
Range 0,4–9,5 L/min
(0.1–2.5 USgpm)

Example:
0.5– 1,9 L/min (0.5 USgpm)

8 Special features

00 – None
(Only required if valve has special features, omitted if "00")
SS – 316 Stainless Steel external components



Dimensions

mm (inch)

Torque cartridge in steel or aluminum housing to 34-41 Nm (25-30 ft.lbs)

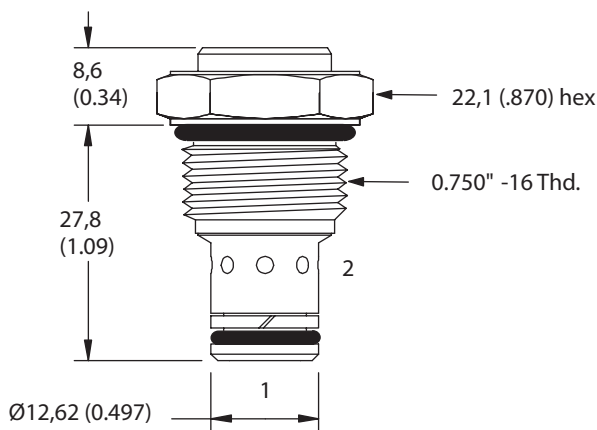

Aluminum housings can be used for pressures up to 210 bar (3000 psi)
Steel housings **must** be used for operating pressures **above** 210 bar (3000 psi)

FR5-10

Flow regulator, fixed

Description

The FR5-10-F is a fixed orifice, pressure compensated, restrictive screw-in flow regulator cartridge valve.

Operation

This valve maintains a constant flow from port 1 to port 2 based on 5.5 bar (80 psid) regardless of pressure changes downstream on port 2. Reverse flow from port 2 to port 1 is at the value of the fixed orifice and is non-pressure compensated.

Functional Symbol

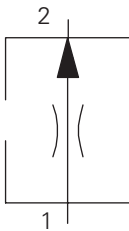

Sectional View

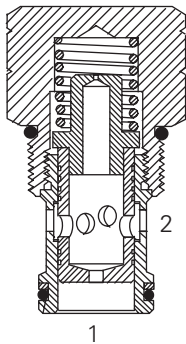

RATINGS AND SPECIFICATIONS

Performance data is typical with fluid at 21,8 cSt (105 SUS) and 49°C (120°F)

Typical application pressure (all ports)	350 bar (5000 psi)
Cartridge fatigue pressure (infinite life)	280 bar (4000 psi)
Rated flow	23 L/min (6 USgpm)
Flow regulation accuracy	0,38–1,9 L/min (0.1–0.49 USgpm) ±20% @ 210 bar (3000 psi) 0,38–1,9 L/min (0.1–0.49 USgpm) ±40% @ 350 bar (5000 psi) 1,9 – 5,7 L/min (0.5–1.49 USgpm) ±15% @ 350 bar (5000 psi) 5,7–22,7 L/min (1.5–6 USgpm) ±10% @ 350 bar (5000 psi)
<small>Factory set maximum flow rate accuracy under standard test conditions and within the above ranges</small>	
Temperature range	–40° to 120°C (–40° to 248°F)
Cavity	C–10–2
Fluids	All general purpose hydraulic fluids such as: MIL–H–5606, SAE 10, SAE 20, etc.
Filtration	Cleanliness code 18/16/13
Standard housing materials	Aluminum or steel
Weight cartridge only	0,12 kg (0.26 lbs.)
Seal kits	565803 Buna-N 566086 Viton®

Viton is a registered trademark of E.I. DuPont

Typical Flow Regulation

Cartridge only

- A – 21 L/min (5.5 USgpm)
- B – 13,3 L/min (3.5 USgpm)
- C – 7,8 L/min (2.0 USgpm)
- D – 0,95 L/min (0.25 USgpm)

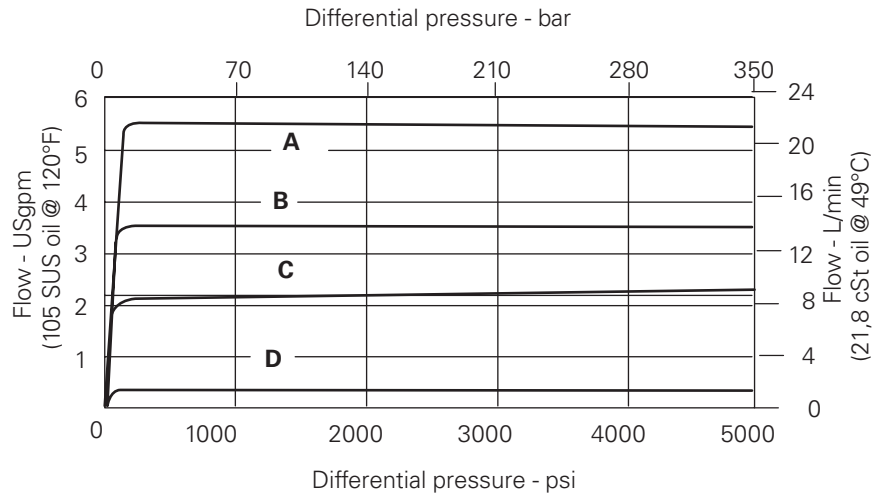

FR 5 – 10 (V) – F – (*) ** – *. * – 00

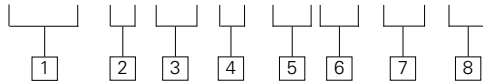

1 Function
FR5 – Flow regulator

2 Size
10 – 10 Size

3 Seals
Blank – Buna-N
V – Viton®

4 Adjustment
F – Fixed orifice

5 Housing material
Omit for cartridge only
A – Aluminum
S – Steel

6 Port size
0 – Cartridge only

CODE	PORT SIZE	HOUSING NUMBER		
		Aluminum Light duty	Aluminum Fatigue rated	Steel Fatigue rated
3B	3/8" BSPP	02-175462	–	–
2G	1/4" BSPP	–	876702	02-175102
3G	3/8" BSPP	–	876703	02-175103
6H	SAE 6	–	876700	–
8H	SAE 8	–	876701	–
6T	SAE 6	566151	–	02-175100
8T	SAE 8	–	–	02-175101

See section J for housing details.

7 Factory set flow rate
(Specify in USgpm)
Range 0,38–22,7 L/min
(0.1–6.0 USgpm)

8 Special features
00 – None
(Only required if valve has special features, omitted if "00")



Dimensions

mm (inch)

Torque cartridge in housing
A – 47-54 Nm (35-40 ft.lbs)
S – 68-75 Nm (50-55 ft.lbs)

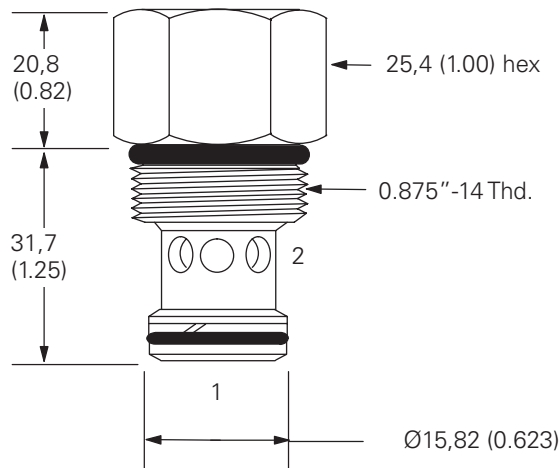

Aluminum housings can be used for pressures up to 210 bar (3000 psi)
Steel housings **must** be used for operating pressures **above** 210 bar (3000 psi)

FR1-16

Flow regulator, fixed

Description

The FR1-16-F is a fixed orifice, pressure compensated, screw-in flow regulator cartridge valve.

Operation

This valve maintains a constant flow from port 1 to port 2 based on 5.5 bar (80 psid) regardless of pressure changes downstream on port 2. Reverse flow from port 2 to port 1 is at the value of the fixed orifice and is non-pressure compensated.

Functional Symbol

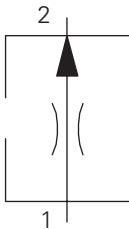

Sectional View

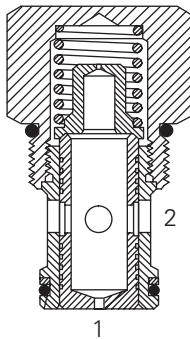

RATINGS AND SPECIFICATIONS

Performance data is typical with fluid at 21,8 cSt (105 SUS) and 49°C (120°F)

Typical application pressure (all ports)	210 bar (3000 psi)
Cartridge fatigue pressure (infinite life)	210 bar (3000 psi)
Rated flow	114 L/min (30 USgpm)
Flow regulation accuracy	1,9–10,9 L/min (0,5–2,9 USgpm) ±15% 11,4–114 L/min (3–30 USgpm) ±10%
<small>Factory set maximum flow rate accuracy under standard test conditions and within the above ranges</small>	
Temperature range	-40° to 120°C (-40° to 248°F)
Cavity	C-16-2
Fluids	All general purpose hydraulic fluids such as: MIL-H-5606, SAE 10, SAE 20, etc.
Filtration	Cleanliness code 18/16/13
Standard housing materials	Aluminum
Weight cartridge only	0,33 kg (0.72 lbs.)
Seal kits	565810 Buna-N 880609 Viton®

Viton is a registered trademark of E.I. DuPont

Typical Flow Regulation

Cartridge only

- A – 114 L/min (30.0 USgpm)
- B – 60 L/min (15.0 USgpm)
- C – 9,5 L/min (2.5 USgpm)

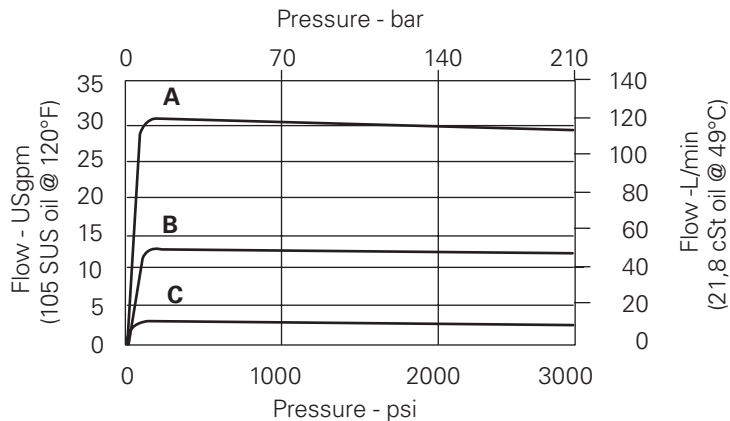

FR 1 – 16 (V) – F – * – *.* – 00**

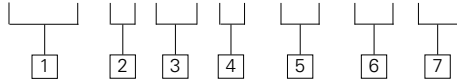

1 Function
FR1 – Flow regulator

2 Size
16 – 16 Size

3 Seals
Blank – Buna-N
V – Viton®

4 Adjustment
F – Fixed orifice

5 Port size
0 – Cartridge only

CODE	PORT SIZE	HOUSING NUMBER	
		Aluminum Light duty	Aluminum Fatigue rated
6B	3/4" BSPP	02-175463	–
12T	SAE 12	566149	–
4G	1/2" BSPP	–	876716
6G	3/4" BSPP	–	876718
10H	SAE 10	–	876717
12H	SAE 12	–	566113

See section J for housing details.

6 Factory set flow rate, nominal
(Specify in USgpm)
Range 1,9–114 L/min
(0.5–30 USgpm)

7 Special features
00 – None
(Only required if valve has special features, omitted if "00")

F

Dimensions

mm (inch)

Torque cartridge in aluminum housing to 108-122 Nm (80-90 ft.lbs)

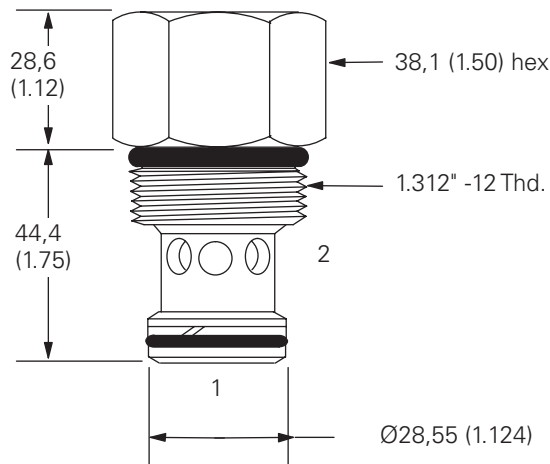

FR1-20

Flow regulator, fixed

Description

The FR1-20-F is a fixed orifice, pressure compensated, screw-in flow regulator cartridge valve.

Operation

This valve maintains a constant flow from port 1 to port 2. Reverse flow from port 2 to port 1 is at the value of the fixed orifice and is non-pressure compensated.

Functional Symbol

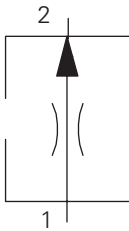

Sectional View

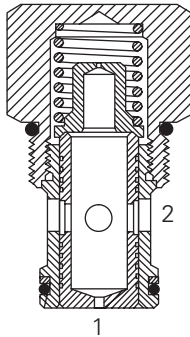

RATINGS AND SPECIFICATIONS

Performance data is typical with fluid at 21,8 cSt (105 SUS) and 49°C (120°F)

Typical application pressure (all ports)	210 bar (3000 psi)
Cartridge fatigue pressure (infinite life)	210 bar (3000 psi)
Rated flow	227 L/min (60 USgpm)
Flow regulation accuracy	3,8–18,5 L/min (1–4,9 USgpm) ±15% 19–227 L/min (5–60 USgpm) ±10%
	<small>Factory set maximum flow rate accuracy under standard test conditions and within the above ranges</small>
Temperature range	–40° to 120°C (–40° to 248°F)
Cavity	C–20–2
Fluids	All general purpose hydraulic fluids such as: MIL–H–5606, SAE 10, SAE 20, etc.
Filtration	Cleanliness code 18/16/13
Standard housing materials	Aluminum
Weight cartridge only	0,82 kg (1.8 lbs.)
Seal kits	889615 Buna-N 889619 Viton®

Viton is a registered trademark of E.I. DuPont

Typical Flow Regulation

Cartridge only

A – 227 L/min (60.0 USgpm)

B – 114 L/min (30.0 USgpm)

C – 38 L/min (10.0 USgpm)

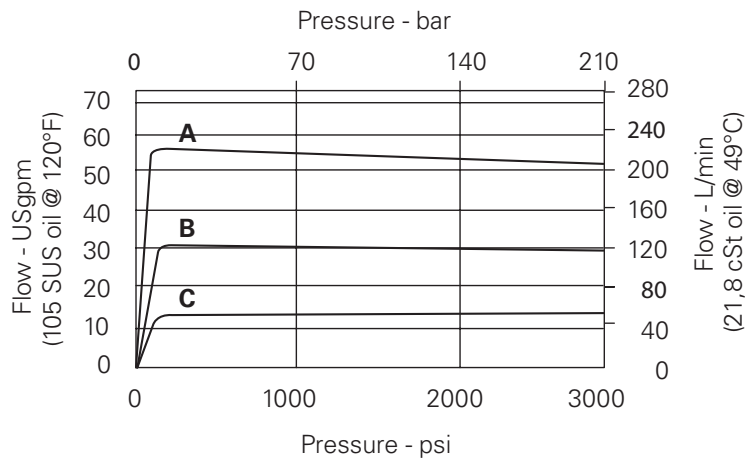

FR 1-20 (V)-F-*-*.*-00**

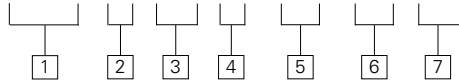

1 Function
FR1 – Flow regulator

2 Size
20 – 20 Size

3 Seals
Blank– Buna-N
V – Viton®

4 Adjustment
F – Fixed orifice

5 Port size
0 – Cartridge only

CODE	PORT SIZE	HOUSING NUMBER	
		Aluminum Light duty	Aluminum Fatigue rated
8B	1" BSPP	02-175464	–
16T	SAE 16	566409	–
6G	3/4" BSPP	–	876732
8G	1" BSPP	–	876734
12H	SAE 12	–	876733
16H	SAE 16	–	876735

See section J for housing details.

6 Factory set flow rate,
(Specify in USgpm)
Range 3,8 – 227 L/min
(0.1 – 60 USgpm)

7 Special features
00 – None
(Only required if valve has special features, omitted if "00")



Dimensions

mm (inch)

Torque cartridge in aluminum housing to 128-155 Nm (95-115 ft.lbs)

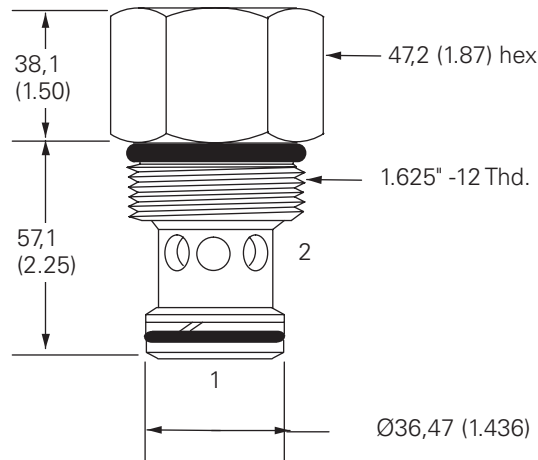

FR2-10

Flow regulator, adjustable

Description

The FR2-10-F is a limited range adjustable*, pressure compensated, screw-in flow regulator cartridge valve.

*The flow adjustment is from the factory set maximum flow rate down to 50% of that factory set flow rate.

Functional Symbol

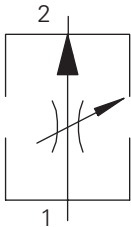

Sectional View

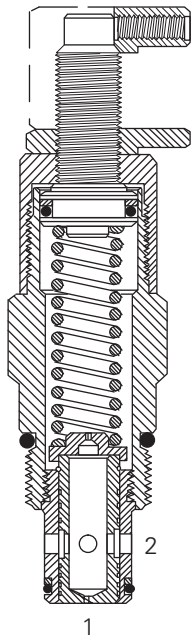

Operation

This valve maintains a constant flow from port 1 to port 2 based on the setting adjustment, regardless of pressure changes downstream on port 2. Reverse flow from port 2 to port 1 is at the value of the fixed orifice and is non-pressure compensated.

RATINGS AND SPECIFICATIONS

<i>Performance data is typical with fluid at 21,8 cSt (105 SUS) and 49°C (120°F)</i>	
Typical application pressure (all ports)	210 bar (3000 psi)
Cartridge fatigue pressure (infinite life)	210 bar (3000 psi)
Rated flow	38 L/min (10 USgpm)
Flow regulation accuracy	0,4–1,9 L/min (0.1–0.49 USgpm) ±20% 1,9–7,5 L/min (0.5–1.99 USgpm) ±15% 7,6–37,8 L/min (2.0–10.0 USgpm) ±10%
<small>Factory set maximum flow rate accuracy under standard test conditions and within the above ranges</small>	
Temperature range	–40° to 120°C (–40° to 248°F)
Cavity	C–10–2
Fluids	All general purpose hydraulic fluids such as: MIL–H–5606, SAE 10, SAE 20, etc.
Filtration	Cleanliness code 18/16/13
Standard housing materials	Aluminum
Weight cartridge only	0,22 kg (.48 lbs.)
Seal kits	565803 Buna-N 566086 Viton®

Viton is a registered trademark of E.I. DuPont

Typical Flow Regulation

Cartridge only

A – 38,0 L/min (10.0 USgpm)

B – 19,0 L/min (5.0 USgpm)

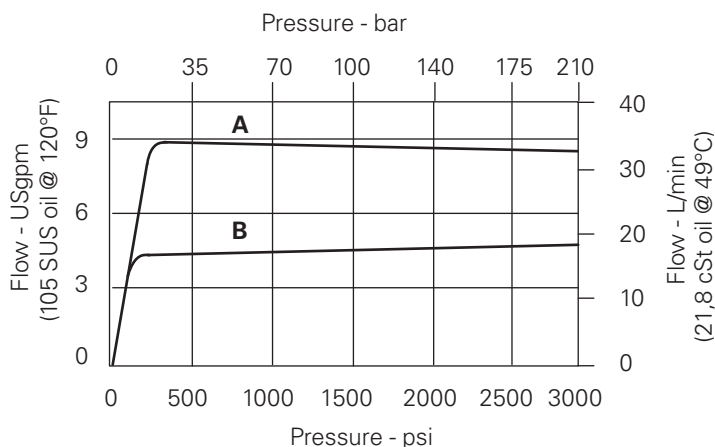

FR 2-10 (V) - * - * - * - * - 00

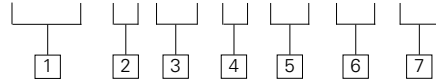

1 Function
FR2 – Flow regulator

2 Size
10 – 10 Size

3 Seals
Blank– Buna-N
V – Viton®

4 Adjustment
C – Cap
F – Factory-set
I – Internal
K – Knob
S – Screw

5 Port size
0 – Cartridge only

CODE	PORT SIZE	HOUSING NUMBER	
		Aluminum light duty	Aluminum Fatigue rated
3B	3/8" BSPP	02-175462	–
6T	SAE 6	566151	–
2G	1/4" BSPP	–	876702
3G	3/8" BSPP	–	876703
6H	SAE 6	–	876700
8H	SAE 8	–	876701

See section J for housing details.

6 Factory set flow rate,
(Specify in USgpm)
Range 0,38–22,7 L/min
(0.1–10.0 USgpm)

7 Special features
00 – None
(Only required if valve has special features, omitted if "00")
SS - 316 Stainless Steel external components



Dimensions
mm (inch)

Torque cartridge in aluminum housing to 47-54 Nm (35-40 ft.lbs)

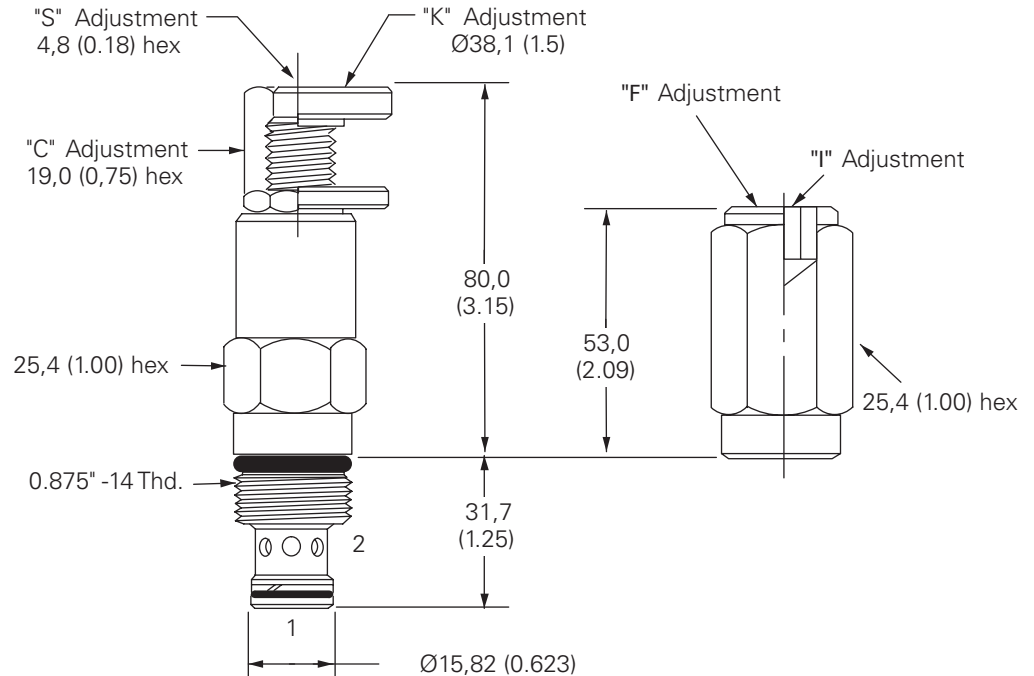

FR2-16

Flow regulator, adjustable

Description

The FR2-16 is a limited range adjustable*, pressure compensated, screw-in flow regulator cartridge valve.

*The flow adjustment is from the factory set maximum flow rate down to 50% of that factory set flow rate.

Functional Symbol

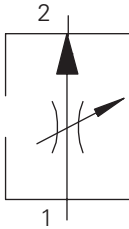

Sectional View

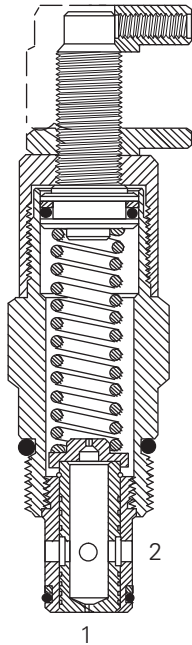

Operation

This valve maintains a constant flow from port 1 to port 2 based on the setting adjustment, regardless of pressure changes downstream on port 2. Reverse flow from port 2 to port 1 is at the value of the fixed orifice and is non-pressure compensated.

RATINGS AND SPECIFICATIONS

Performance data is typical with fluid at 21,8 cSt (105 SUS) and 49°C (120°F)

Typical application pressure (all ports)	210 bar (3000 psi)
Cartridge fatigue pressure (infinite life)	210 bar (3000 psi)
Rated flow	114 L/min (30 USgpm)
Flow regulation accuracy	1,9–10,9 L/min (0,5–2,9 USgpm) ±15% 11,4–114 L/min (3–30 USgpm) ±10%
<small>Factory set maximum flow rate accuracy under standard test conditions and within the above ranges</small>	
Temperature range	–40° to 120°C (–40° to 248°F)
Cavity	C-16-2
Fluids	All general purpose hydraulic fluids such as: MIL-H-5606, SAE 10, SAE 20, etc.
Filtration	Cleanliness code 18/16/13
Standard housing materials	Aluminum
Weight cartridge only	0,71 kg (1,57 lbs.)
Seal kits	565810 Buna-N 889609 Viton®

Viton is a registered trademark of E.I. DuPont

Typical Flow Regulation

Cartridge only

- A** – 114 L/min (30.0 USgpm)
- B** – 38 L/min (10.0 USgpm)
- C** – 9,5 L/min (2.5 USgpm)

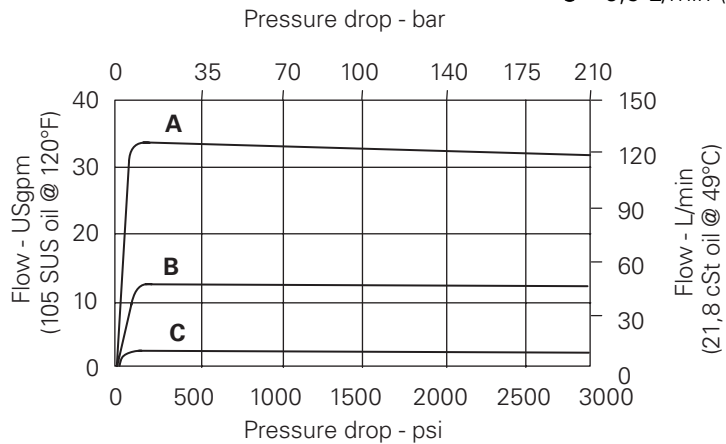

FR 2 - 16 (V) - * - * - *. * - 00**

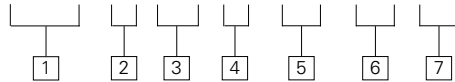

1 Function
FR2 – Flow regulator

2 Size
16 – 16 Size

3 Seals
Blank – Buna-N
V – Viton®

4 Adjustment
K – Knob
S – Screw
C – Cap
Y – Knob (Stainless)

5 Port size
0 – Cartridge only

CODE	PORT SIZE	HOUSING NUMBER	
		Aluminum Light duty	Aluminum Fatigue rated
6B	3/4" BSPP	02-175463	–
12T	SAE 12	566149	–
4G	1/2" BSPP	–	876716
6G	3/4" BSPP	–	876718
10H	SAE 10	–	876717
12H	SAE 12	–	876713

See section J for housing details.

6 Factory set flow rate,
(Specify in USgpm)
Range 1,9–114 L/min
(0.5–30 USgpm)

7 Special features
00 – None
(Only required if valve has special features, omitted if "00")
SS - 316 Stainless Steel external components



Dimensions

mm (inch)

Torque cartridge in aluminum housing to 108-122 Nm (80-90 ft.lbs)

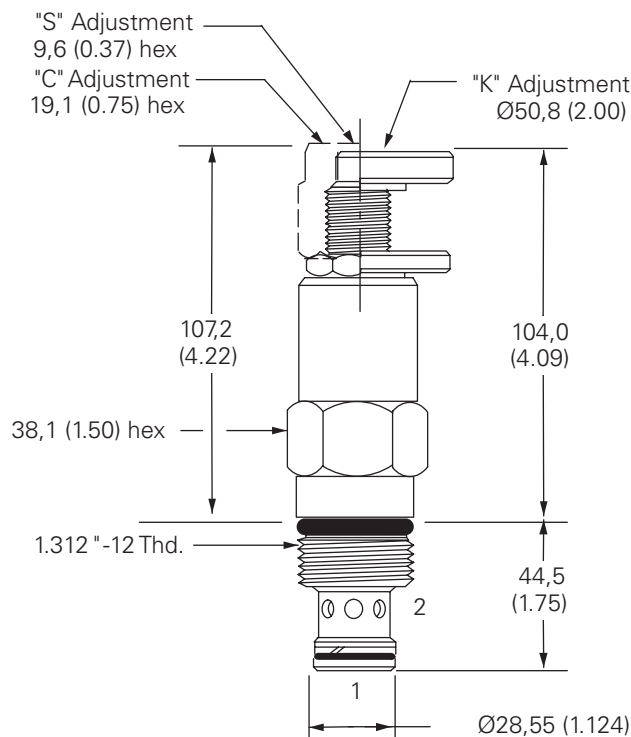

FAR1-10

Flow regulator, pressure compensated, fully adjustable

Description

The FAR1-10 is a two-way, **fully adjustable**, pressure compensated, flow regulator, screw-in cartridge valve with free reverse flow.

Functional Symbol

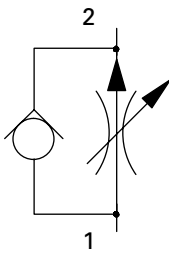

Sectional View

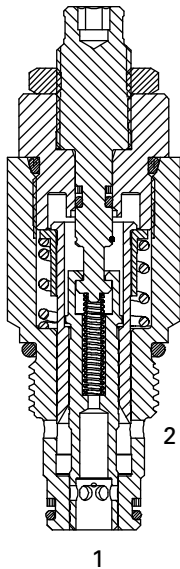

Operation

This valve maintains a constant flow from port 1 to port 2 regardless of pressure changes upstream of port 1, or downstream of port 2. 13.8 bar (200 psi)

must be maintained across the valve to obtain pressure compensated control. The regulated flow base within the adjusting range from 1 to 38 lpm (0.25 to 10

USgpm) is set by turning the adjusting screws clockwise to decrease the flow and counter-clockwise to increase the flow. This valve allows free reverse flow from port 2 to port 1.

RATINGS AND SPECIFICATIONS

Performance data is typical with fluid at 21,8 cSt (105 SUS) and 49°C (120°F)

Typical application pressure (all ports)	5–350 bar (75–5000 psi) steel housing
Min. pressure differential across valve	14 bar (200 psi)
Cartridge fatigue pressure (infinite life)	310 bar (4500 psi)
Rated flow	1–38 L/min (.25–10 USgpm)
Flow regulation accuracy	4–38 L/min (1–10 USgpm) ±10% 1–4 L/min (0.25–1 USgpm) ±20%

Factory set maximum flow rate accuracy under standard test conditions and within the above ranges

Reverse check crack pressure	1.7 bar (25 psi)
Leakage at shutoff position	0.4 L/min (24.4 in ³ /min)
Temperature range	–40° to 120°C (–40° to 248°F)
Cavity	C–10–2
Fluids	All general purpose hydraulic fluids such as: MIL-H–5606, SAE 10, SAE 20, etc.
Filtration	Cleanliness code 18/16/13
Standard housing materials	Aluminum or steel
Weight cartridge only	“S” 0,02 kg (0.44 lbs.) “K” 0,23 kg (0.51 lbs.) “H” 0,26 kg (0.59 lbs.)

Seal kits	565803 Buna-N 566086 Viton®
-----------	--------------------------------

Viton is a registered trademark of E.I. DuPont

Typical Flow Regulation

Cartridge only

PRESSURE DROP FOR REVERSE FLOW

Flow - L/min (21,8 cSt oil @ 49°C)

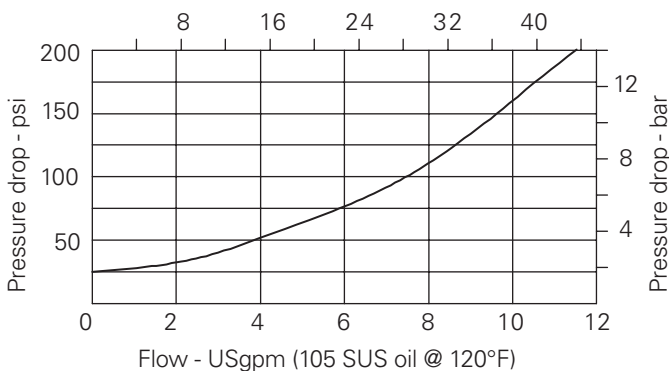

TYPICAL FLOW REGULATION

Pressure differential across valve in bar

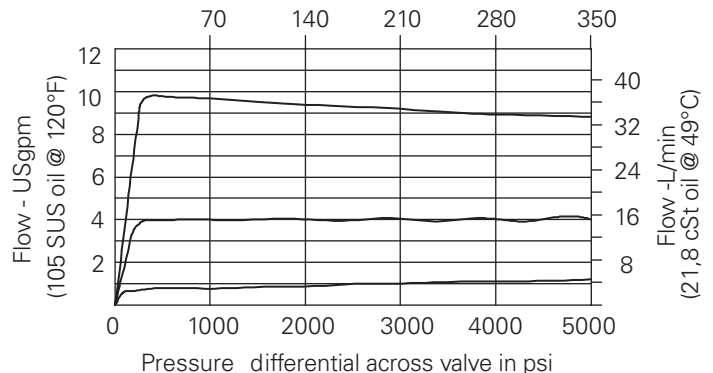

FAR1-10 (V)-*--**-*.*-00**

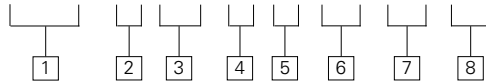

1 Function

FAR1 – Fully adjustable, pressure compensated flow regulator with reverse flow check

2 Size

10 – 10 Size

3 Seals

Blank– Buna-N
V – Viton®

4 Adjustment

S – Screw with locknut
K – Handknob with locknut
H – Calibrated handknob with locknut

5 Valve housing material

Omit for cartridge only
S – Steel
A – Aluminum

6 Port size

0 – Cartridge only

CODE	PORT SIZE	HOUSING NUMBER		
		Aluminum Light duty	Aluminum Fatigue rated	Steel Fatigue rated
3B	3/8" BSPP	02-175462	–	–
2G	1/4" BSPP	–	876702	02-175102
3G	3/8" BSPP	–	876703	02-175103
6H	SAE 6	–	876700	–
8H	SAE 8	–	876701	–
6T	SAE 6	566151	–	02-175100
8T	SAE 8	–	–	02-175101

See section J for housing details.

7 Factory set flow rate,

Blank – Normal factory setting at 5 USgpm
User requested setting within .25–10 US gpm (1–38 L/min.)

8 Special features

00 – None
(Only required if valve has special features, omitted if "00".)

Dimensions

mm (inch)

Torque cartridge in housing

A – 47–54 Nm (35–40 ft.lbs)

S – 68–75 Nm (50–55 ft.lbs)

"K" adjustment kit – 565585

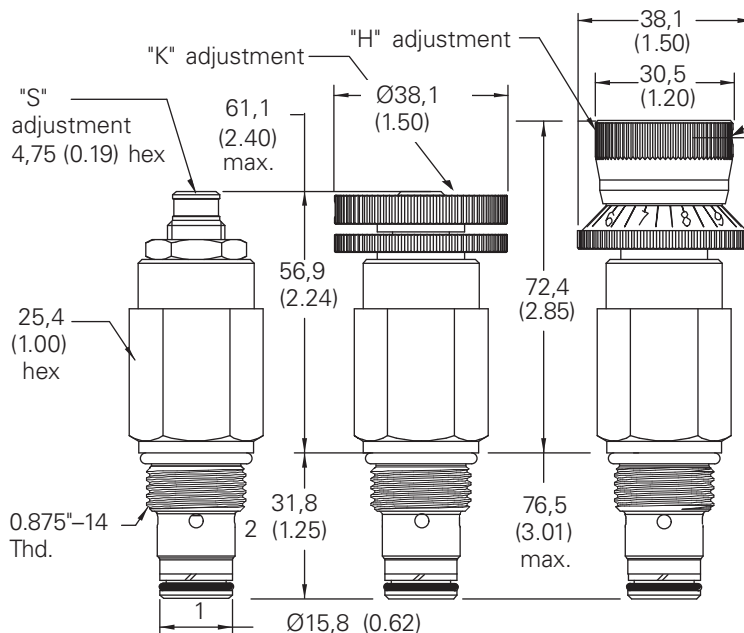

NOTE:

To reset scale and knob to an optimum viewing position:

1. Loosen the set screw
2. Rotate zero point on scale to a desired orientation.
3. Align mark on knob with zero on scale.
4. Tighten the set screw firmly.

To change the setting:

1. Loosen the set screw
2. Loosen jamnut while holding the knob steady, or move the knob along the axis slightly.
3. Turn adjusting screw (jamnut and knob will turn at the same time).
4. At the new adjusting screw position, tighten jamnut firmly while holding the knob steady, or move the knob along axis slightly.
5. Tighten the set screw firmly.



Aluminum housings can be used for pressures up to 210 bar (3000 psi)

Steel housings **must** be used for operating pressures **above** 210 bar (3000 psi)

FAR1-12

Flow regulator, pressure compensated, fully adjustable

Description

The FAR1-12 is a two-way, **fully adjustable**, pressure compensated, flow regulator, screw-in cartridge valve with free reverse flow.

Functional Symbol

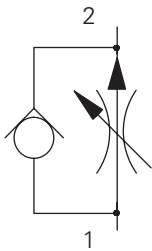

Sectional View

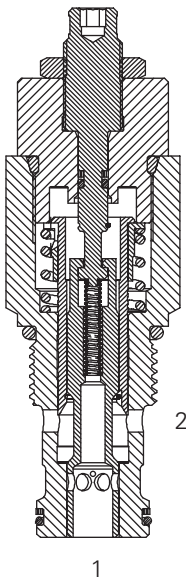

Operation

This valve maintains a constant flow from port 1 to port 2 regardless of pressure changes upstream of port 1, or downstream of port 2. 15,9 bar (230 psi) must be maintained across

the valve to obtain pressure compensated control. The regulated flow base within the adjusting range from 1,5 to 94,5 lpm (0.4 to 25 USgpm) is set by turning the adjusting screws

clockwise to decrease the flow and counter-clockwise to increase the flow. This valve allows free reverse flow from port 2 to port 1.

RATINGS AND SPECIFICATIONS

Performance data is typical with fluid at 21,8 cSt (105 SUS) and 49°C (120°F)

Typical application pressure (all ports)	350 bar (5000 psi)
Cartridge fatigue pressure (infinite life)	315 bar (4500 psi)
Min. pressure differential across valve	15,9 bar (230 psi)
Max. pressure differential across valve	329 bar (4770 psi)
Rated flow	1,5–94,5 L/min (.4–25 USgpm)
Flow regulation accuracy	1,5–3,8 L/min (.4–1.0 USgpm) ±20% @5000 psi above 3,8–68,1 L/min (above 1–18 USgpm) ±10% @3000 psi above 68,1–94,6 L/min (above 18–25 USgpm) ±15% @3000 psi 3,8–56,8 L/min (1–15 USgpm) ±10% @5000 psi above 56,8–89,1 L/min (above 15–23 USgpm) ±15% @5000 psi <small>Factory set maximum flow rate accuracy under standard test conditions and within the above ranges</small>
Reverse check crack pressure	1,7 bar (25 psi)
Leakage at shutoff position	0,5 L/min (30 in ³ /min)
Temperature range	–40° to 120°C (–40° to 248°F)
Cavity	C–12–2 & C–12–2U
Fluids	All general purpose hydraulic fluids such as: MIL–H–5606, SAE 10, SAE 20, etc.
Filtration	Cleanliness code 18/16/13
Standard housing materials	Aluminum or steel
Weight cartridge only	“S” 0,43 kg (0.95 lbs.)
	Seal kits 02–181304 Buna-N 02–181305 Viton® <small>Viton is a registered trademark of E.I. DuPont</small>

Typical Flow Regulation

Cartridge only

PRESSURE DROP FOR REVERSE FLOW
Flow - L/min (21,8 cSt oil @ 49 °C)

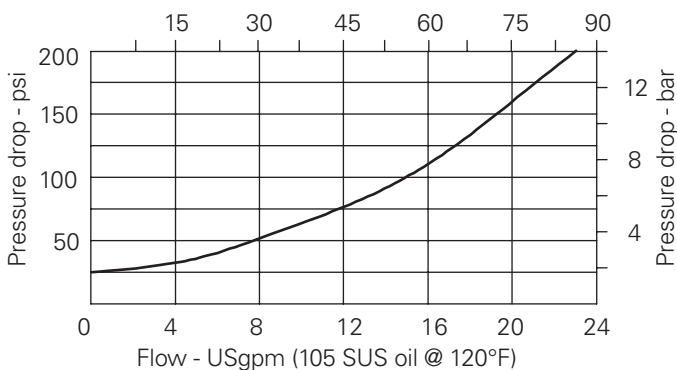

TYPICAL FLOW REGULATION
Pressure differential across valve in bar

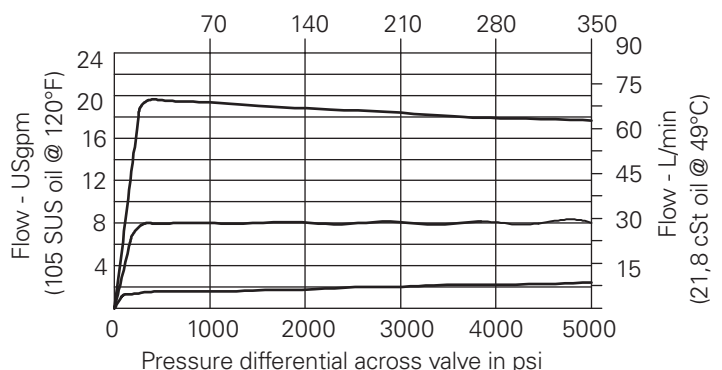

FAR1-12 (V) - * - * - ** - * . * - 00

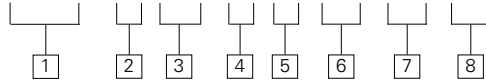

1 Function

FAR1 – Fully adjustable, pressure compensated flow regulator with reverse flow check

2 Size

12 – 12 Size

3 Seals

Blank– Buna-N
V – Viton®

4 Adjustment

S – Screw with locknut
K – Handknob with locknut
H – Calibrated handknob with locknut

5 Valve housing material

Omit for cartridge only
S – Steel
A – Aluminum

6 Port size

0 – Cartridge only

CODE PORT SIZE HOUSING NUMBER

CODE	PORT SIZE	C-12-2U Aluminum Fatigue rated	C-12-2 Aluminum Fatigue rated	C-12-2U Steel Fatigue rated	C-12-2 Steel Fatigue rated
10T(U)	SAE 10	02-160641	02-160640	02-169817	02-169744
12T(U)	SAE 12	02-160645	02-160644	02-169790	02-169782
4G(U)	1/2" BSPP	02-161116	02-161118	02-172512	02-172062
6G(U)	3/4" BSPP	02-161115	02-161117	02-162922	02-169665

See section J for housing details.

7 Factory set flow rate,

Blank – Normal factory setting at 10 USgpm
User requested setting
Within .04–25 US gpm (1,5–94,6 L/min.) up to 210 bar (3000 psi)
Within 0.4-23 USgpm (1,5-87,1 L/min.) up to 350bar (5000 psi)

8 Special features

00 – None
(Only required if valve has special features, omitted if "00".)

NOTE:

To reset scale and knob to an optimum viewing position:

1. Loosen the set screw.
2. Rotate zero point on scale to a desired orientation.
3. Align mark on knob with zero on scale.
4. Tighten the set screw firmly.

To change the setting:

1. Loosen the set screw.
2. Loosen jamnut while holding the knob steady, or move the knob along the axis slightly.
3. Turn adjusting screw (jamnut and knob will turn at the same time).
4. At the new adjusting screw position, tighten jamnut firmly while holding the knob steady, or move the knob along axis slightly.
5. Tighten the set screw firmly.



Aluminum housings can be used for pressures up to 210 bar (3000 psi)
Steel housings **must** be used for operating pressures **above** 210 bar (3000 psi)

Dimensions

mm (inch)

Torque cartridge in housing

A – 81–95 Nm (60–70 ft.lbs)
S – 102–115 Nm (75–85 ft.lbs)

"K" adjustment kit – 565585

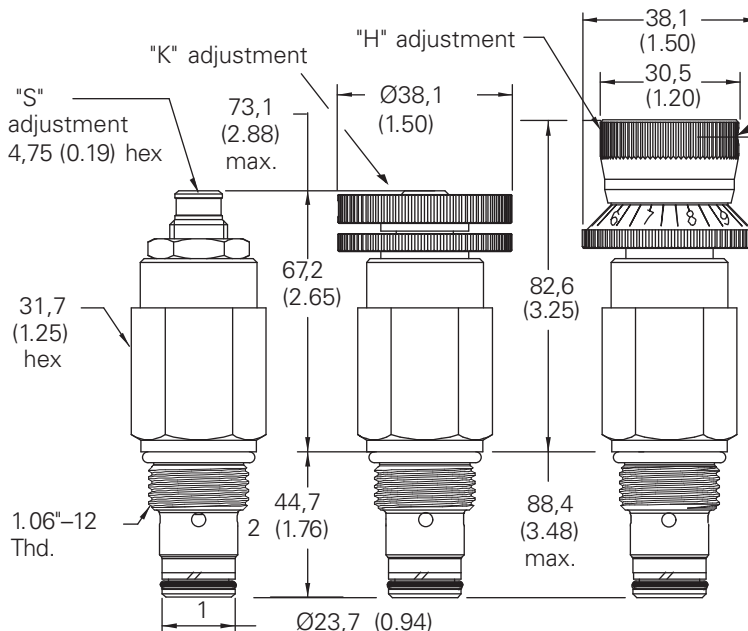

FAR1-16

Flow regulator, pressure compensated, fully adjustable

Description

The FAR1-16 is a two-way, fully adjustable, pressure compensated, flow regulator screw-in cartridge valve.

Functional Symbol

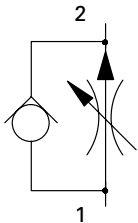

Sectional View

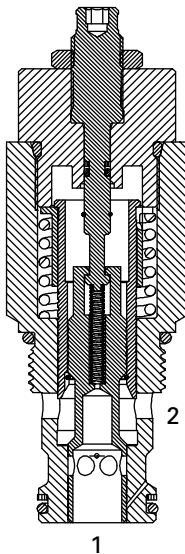

Operation

This valve maintains a constant flow from port 1 to port 2 regardless of pressure changes upstream of port 1, or downstream of port 2. 17 bar (250 psi)

must be maintained across the valve to obtain pressure compensated control. The regulated flow base within the adjusting range from 3,8 to 113,6 L/min (1.0 to 30

USgpm) is set by turning the adjusting screws clockwise to decrease the flow and counter-clockwise to increase the flow. This valve allows free reverse flow from port 2 to port 1.

RATINGS AND SPECIFICATIONS

Performance data is typical with fluid at 21,8 cSt (105 SUS) and 49°C (120°F)

Typical application pressure (all ports)	350 bar (5000 psi)
Cartridge fatigue pressure (infinite life)	310 bar (4500 psi)
Min. pressure differential across valve	17 bar (250 psi)
Max. pressure differential across valve	328 bar (4750 psi)
Rated flow	3,8–113,6 L/min (1–30 USgpm)
Flow regulation accuracy	3,8–15,1 L/min (1.0–4.0 USgpm) ±30% @5000 psi above 15,1–30,3 L/min (above 4.0–8.0 USgpm) ±20% @5000 psi above 30,3–113,6 L/min (above 8.0–30.0 USgpm) ±10% @5000 psi <small>Factory set maximum flow rate accuracy under standard test conditions and within the above ranges</small>
Reverse check crack pressure	1,7 bar (25 psi)
Leakage at shutoff position	0,55 L/min (33.5 in ³ /min)
Temperature range	–40° to 120°C (–40° to 248°F)
Cavity	C–16–2
Fluids	All general purpose hydraulic fluids such as: MIL–H–5606, SAE 10, SAE 20, etc.
Filtration	Cleanliness code 18/16/13
Standard housing materials	Aluminum or steel
Weight cartridge only	"S" 0,67 kg (1.48 lbs.) "K" 0,70 kg (1.55 lbs.) "H" 0,74 kg (1.62 lbs.)
Seal kits	565810 Buna-N 889609 Viton® <small>Viton is a registered trademark of E.I. DuPont</small>

Typical Flow Regulation

Cartridge only

PRESSURE DROP FOR REVERSE FLOW
Flow - L/min (21,8 cSt oil @ 49°C)

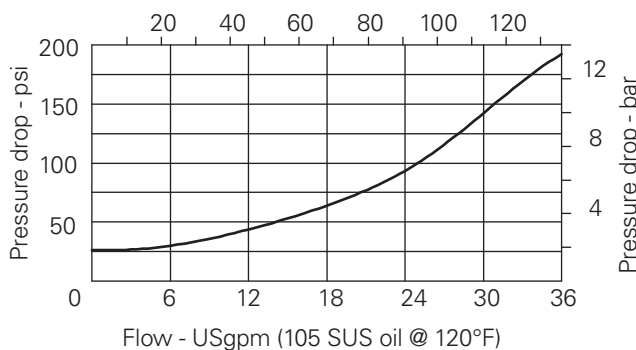

TYPICAL FLOW REGULATION

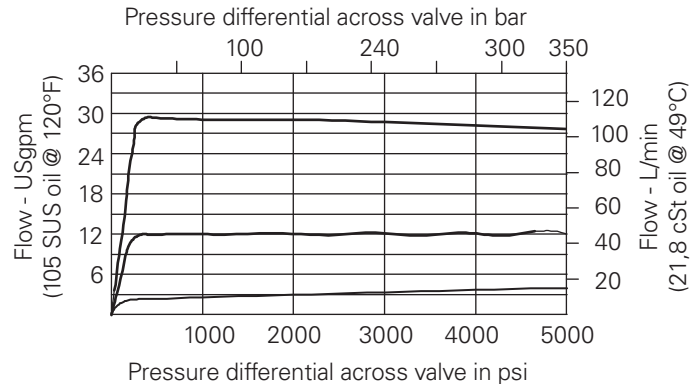

FAR1 - 16 (V) - * - * - * - * - * - * - * - 00

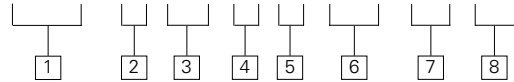

1 Function

FAR1 – Fully adjustable, pressure compensated flow regulator with reverse flow check

2 Size

16 – 16 Size

3 Seals

Blank– Buna-N
V – Viton®

4 Adjustment

S – Screw with locknut
K – Handknob with locknut
H – Calibrated handknob with locknut

5 Valve housing material

Omit for cartridge only
S – Steel
A – Aluminum

6 Port size & valve bodies

0 – Cartridge only

CODE	PORT SIZE	HOUSING NUMBER		
		Aluminum Light duty	Aluminum Fatigue rated	Steel Fatigue rated
4G	1/2" BSPP	–	876716	02-175106
6B	3/4" BSPP	02-175463	–	–
6G	3/4" BSPP	–	876718	02-175107
10T	SAE 10	–	–	–
10H	SAE 10	–	876717	02-175104
12T	SAE 12	566149	–	–
12H	SAE 12	–	566113	02-175105

See section J for housing details.

7 Factory set flow rate

Blank – Normal factory setting at 15 USgpm
User requested setting
Within 1–30 USgpm
(3,8–113,6 L/min.)

8 Special features

00 – None
(Only required if valve has special features, omitted if "00")

NOTE:

To reset scale and knob to an optimum viewing position:

1. Loosen the set screw.
2. Rotate zero point on scale to a desired orientation.
3. Align mark on knob with zero on scale.
4. Tighten the set screw firmly.

To change the setting:

1. Loosen the set screw.
2. Loosen jamnut while holding the knob steady, or move the knob along the axis slightly.
3. Turn adjusting screw (jamnut and knob will turn at the same time).
4. At the new adjusting screw position, tighten jamnut firmly while holding the knob steady, or move the knob along axis slightly.
5. Tighten the set screw firmly.
"K" adjustment kit – 02-185169



Aluminum housings can be used for pressures up to 210 bar (3000 psi)
Steel housings **must** be used for operating pressures **above** 210 bar (3000 psi)

Dimensions

mm (inch)

Torque cartridge in housing

A – 108–122 Nm (80–90 ft.lbs)
S – 136–149 Nm (100–110 ft.lbs)

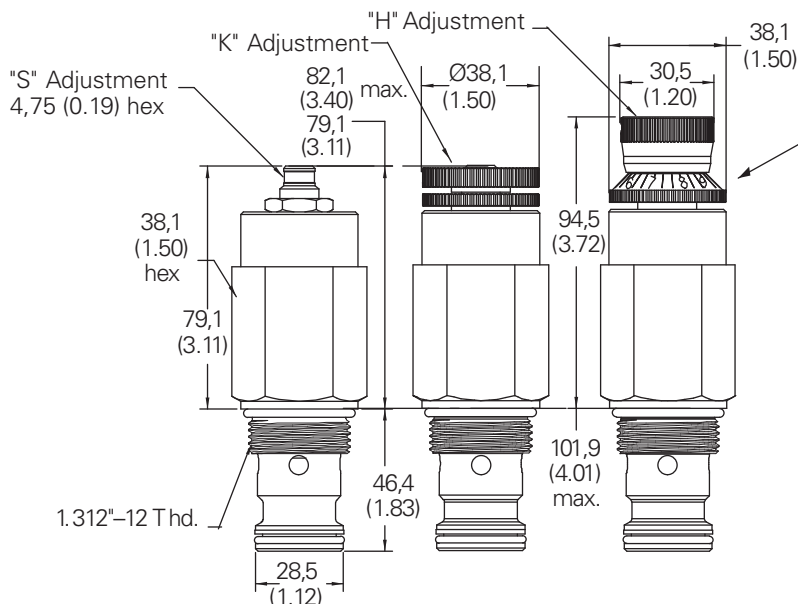

PFR5-8

Priority flow regulator, fixed

Description

The PFR5-8 is a fixed orifice, priority type, pressure compensated, flow regulator, screw-in cartridge valve.

Operation

This valve maintains a constant, factory-set, priority flow from port 1 to port 3 based on 5.5 bar (80 psid) regardless of pressure

changes downstream on port 3. Flow in excess of the priority setting is directed to port 2. If the priority flow at port 3 is blocked,

the spool will shift to try and satisfy the priority flow requirement, thereby closing off flow to port 2.

Functional Symbol

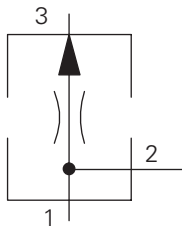

Sectional View

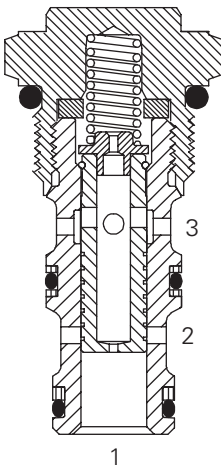

RATINGS AND SPECIFICATIONS

Performance data is typical with fluid at 21,8 cSt (105 SUS) and 49°C (120°F)

Typical application pressure (all ports)	350 bar (5000 psi) in steel housing
Cartridge fatigue pressure (infinite life)	280 bar (4000 psi)
Rated flow	maximum inlet flow 15,1 L/min (4 USgpm) maximum regulated flow 10 L/min (2.5 USgpm)
Internal leakage	82 cm ³ /min. @ 350 bar (3000 psi) 5 in ³ /min @ 5000 psi
Flow regulation accuracy	0,4–1,9 L/min (0.1–0.49 USgpm) ±20% @ 210 bar (3000 psi) 0,4–1,9 L/min (0.1–0.49 USgpm) ±40% @ 350 bar (5000 psi) 1,9–5,7 L/min (0.5–1.49 USgpm) ±15% @ 350 bar (5000 psi) 5,7–10 L/min (1.5–2.5 USgpm) ±10% @ 350 bar (5000 psi)

Factory set maximum priority flow rate accuracy under standard test conditions and within the above ranges

Temperature range	-40° to 120°C (-40° to 248°F)
Cavity	C-8-3
Fluids	All general purpose hydraulic fluids such as: MIL-H-5606, SAE 10, SAE 20, etc.
Filtration	Cleanliness code 18/16/13
Standard housing materials	Aluminum or steel
Weight cartridge only	0,07 kg (0.15 lb.)
Seal kits	02-173427 Buna-N 02-173434 Viton®

Viton is a registered trademark of E.I. DuPont

Typical Flow Regulation

Cartridge only

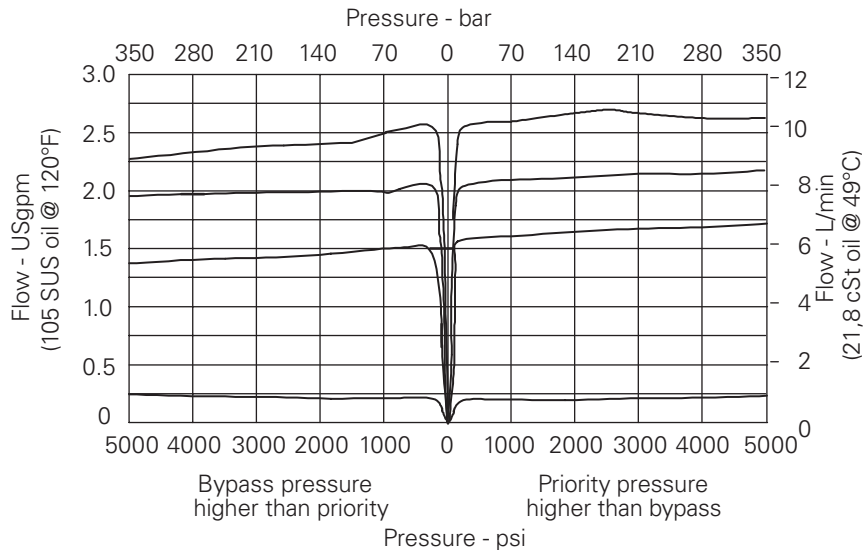

PFR5-8 (V)-F-(*)--*. *-00**

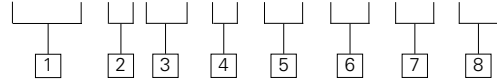

1 Function
PFR5 – Priority flow regulator

2 Size
8 – 8 Size

3 Seals
Blank – Buna-N
V – Viton®

4 Adjustment
F – Fixed orifice

5 Valve housing material
Omit for cartridge only
S – Steel
A – Aluminum

6 Port size
0 – Cartridge only

CODE	PORT SIZE	HOUSING NUMBER	
		Aluminum Fatigue rated	Steel Fatigue rated
4T	SAE 4	02-160741	02-160745
6T	SAE 6	02-160742	02-160746
2G	1/4" BSPP	02-160739	02-160743
3G	3/8" BSPP	02-160740	02-160744

See section J for housing details.

7 Factory set flow rate,
(Specify in USgpm)
Range 0,4–9,5 L/min
(0.1–2.5 USgpm)
Example:
0.5–1,9 L/min (0.5 USgpm)

8 Special features
00 – None
(Only required if valve has
special features, omitted
if "00")
SS - 316 Stainless Steel
external components



Dimensions

mm (inch)

Torque cartridge in steel
or aluminum housing to
34–41 Nm (25–30 ft.lbs)

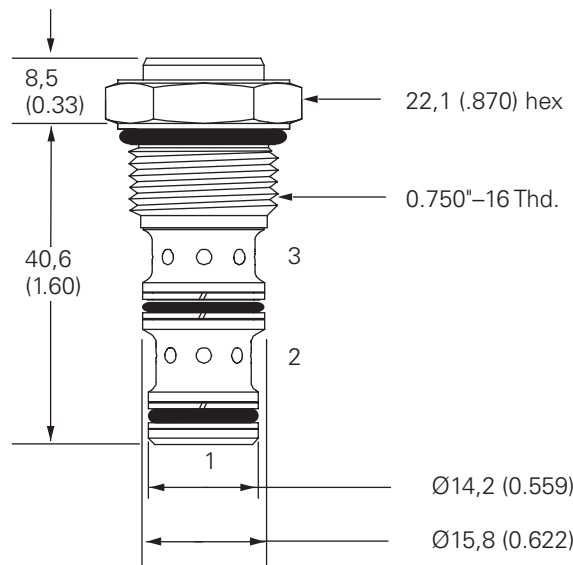

Aluminum hous-
ings can be used
for pressures up to
210 bar (3000 psi)
Steel housings **must** be used
for operating pressures **above**
210 bar (3000 psi)

PFR5-10

Priority flow regulator, fixed

Description

The PFR5-10-F is a fixed orifice, priority type, pressure compensated, flow regulator screw-in cartridge valve.

Operation

This valve maintains a constant, factory-set, priority flow from port 1 to port 3 based on 5.5 bar (80 psid) regardless of pressure

changes downstream on port 3. Flow in excess of the priority setting is directed to port 2. If the priority flow at port 3 is blocked,

the spool will shift to satisfy the priority flow requirement, thereby closing off flow to port 2.

Functional Symbol

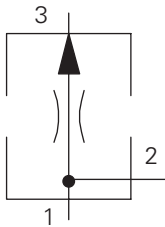

Sectional View

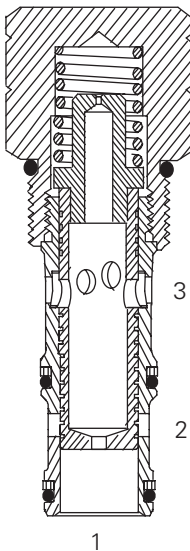

RATINGS AND SPECIFICATIONS

Performance data is typical with fluid at 21,8 cSt (105 SUS) and 49°C (120°F)

Typical application pressure (all ports)	350 bar (5000 psi)
Cartridge fatigue pressure (infinite life)	280 bar (4000 psi)
Rated flow	Maximum inlet flow 60 L/min (15 USgpm) Maximum regulated flow 23 L/min (6 USgpm)
Flow regulation accuracy	0,4–1,9 L/min (0.1–0.49 USgpm) ±20% @ 210 bar (3000 psi) 0,4–1,9 L/min (0.1–0.49 USgpm) ±40% @ 350 bar (5000 psi) 1,9–5,7 L/min (0.5–1.49 USgpm) ±15% @ 350 bar (5000 psi) 5,7–22,7 L/min (1.5–6 USgpm) ±10% @ 350 bar (5000 psi)
Factory set maximum priority flow rate accuracy under standard test conditions and within the above ranges.	
Temperature range	-40° to 120°C (-40° to 248°F)
Cavity	C-10-3
Fluids	All general purpose hydraulic fluids such as: MIL-H-5606, SAE 10, SAE 20, etc.
Filtration	Cleanliness code 18 /16/13
Standard housing materials	Aluminum or steel
Weight cartridge only	0,13 kg (0.28 lb.)
Seal kits	565804 Buna-N 889599 Viton®

Viton is a registered trademark of E.I. DuPont

Typical Flow Regulation

Cartridge only

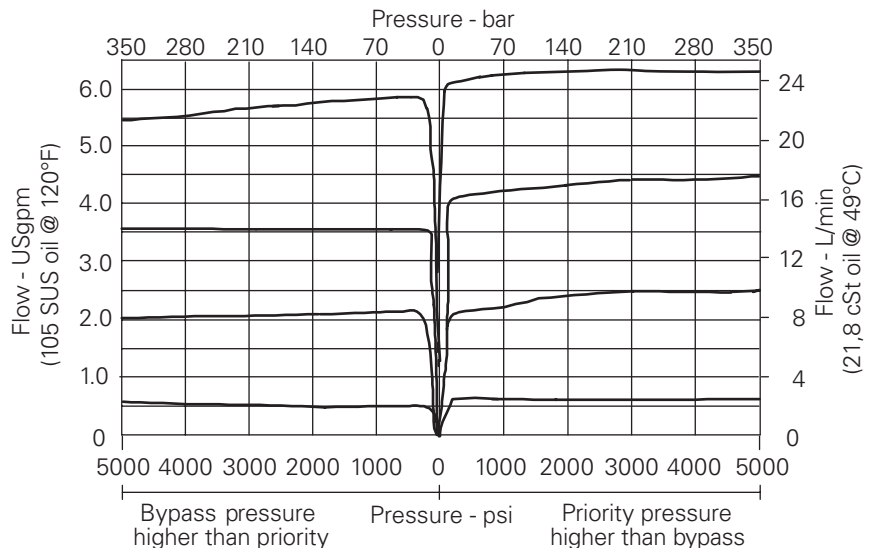

PFR5 – 10 (V) – F – * – ** – *.* – 00

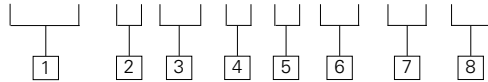

1 Function
PFR5 – Priority flow regulator

2 Size
10 – 10 Size

3 Seals
Blank – Buna-N
V – Viton®

4 Adjustment
F – Fixed orifice

5 Valve housing material
Omit for cartridge only
S – Steel
A – Aluminum

6 Port size
0 – Cartridge only

CODE	PORT SIZE	HOUSING NUMBER		
		Aluminum Light duty	Aluminum Fatigue rated	Steel
2G	1/4" BSPP	–	876705	02-175127
3B	3/8" BSPP	02-173358	–	–
3G	3/8" BSPP	–	876714	02-175128
6T	SAE 6	566162	–	02-175124
6H	SAE 6	–	876704	–
8H	SAE 8	–	876711	–
8T	SAE 8	–	02-175125	–

See section J for housing details.

7 Factory set flow rate
(Specify in USgpm)
Range 0,38–22,7 L/min
(0.1–6.0 USgpm)

8 Special features
00 – None
(Only required if valve has special features, omitted if "00")



Dimensions

mm (inch)

Torque cartridge in housing

A – 47–54 Nm (35–40 ft.lbs)

S – 68–75 Nm (50–55 ft.lbs)

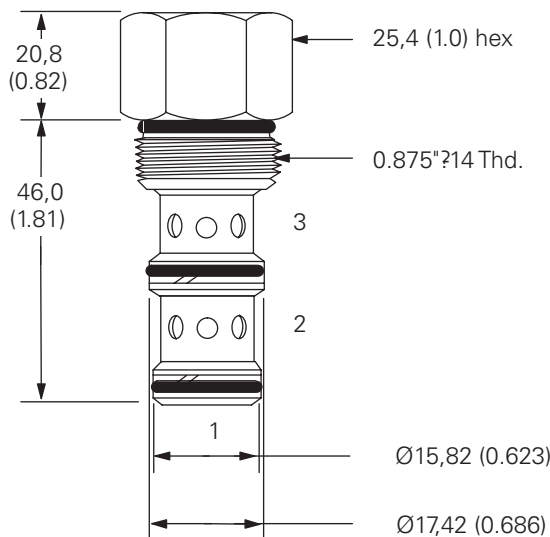

Aluminum housings can be used for pressures up to 210 bar (3000 psi)
Steel housings **must** be used for operating pressures **above** 210 bar (3000 psi)

PFR1-16

Priority flow regulator, fixed

Description

The PFR1-16-F is a fixed orifice, priority type, pressure compensated, flow regulator screw-in cartridge valve.

Functional Symbol

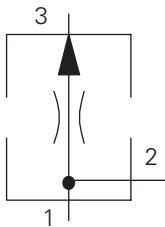

Sectional View

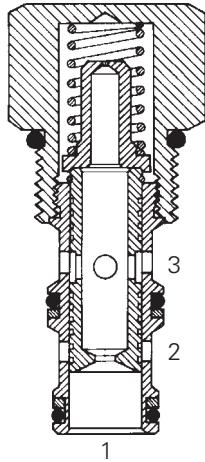

Operation

This valve maintains a constant, factory-set, priority flow from port 1 to port 3 based on 5.5 bar (80 psid) regardless of pressure

changes downstream on port 3. Flow in excess of the priority setting is directed to port 2. If the priority flow at port 3 is blocked,

the spool will shift to satisfy the priority flow requirement, thereby closing off flow to port 2.

RATINGS AND SPECIFICATIONS

Performance data is typical with fluid at 21,8 cSt (105 SUS) and 49°C (120°F)

Typical application pressure (all ports)	210 bar (3000 psi)
Cartridge fatigue pressure (infinite life)	210 bar (3000 psi)
Rated flow	Maximum inlet flow 151 L/min (40 USgpm) Maximum regulated flow 114 L/min (30 USgpm)
Flow regulation accuracy	1,9–10,9 L/min (0,5–2,9 USgpm) ±15% 11,4–114 L/min (3–30 USgpm) ±10% <small>Factory set maximum priority flow rate accuracy under standard test conditions and within the above ranges</small>
Temperature range	-40° to 120°C (-40° to 248°F)
Cavity	C-16-3
Fluids	All general purpose hydraulic fluids such as: MIL-H-5606, SAE 10, SAE 20, etc.
Filtration	Cleanliness code 18/16/13
Standard housing materials	Aluminum
Weight cartridge only	0,38 kg (0.84 lb.)
Seal kits	565811 Buna-N 889610 Viton® <small>Viton is a registered trademark of E.I. DuPont</small>

Typical Flow Regulation

Cartridge only

- A – Port 3, priority (regulated outlet) pressurized.
- B – Port 2, (bypass outlet) pressurized.

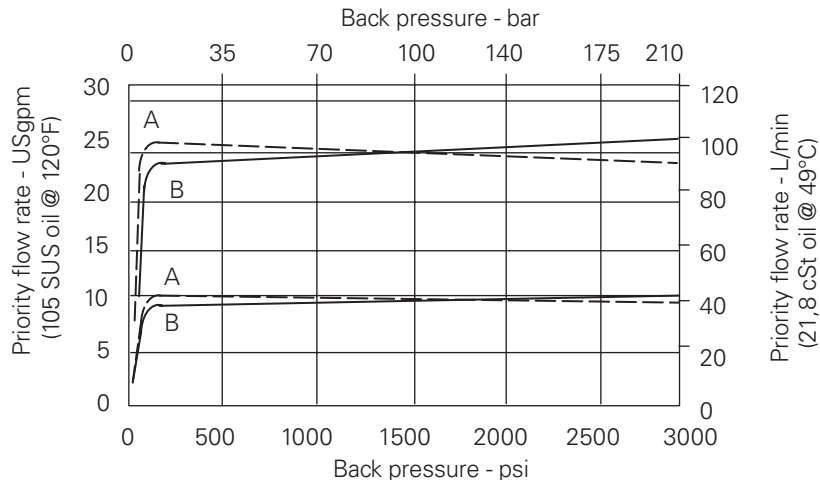

PFR1 – 16 (V) – F – * – * . * – 00**

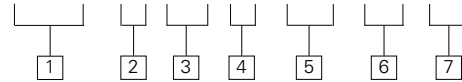

1 Function
PFR1 – Priority flow regulator

2 Size
16 – 16 Size

3 Seals
Blank– Buna-N
V – Viton®

4 Adjustment
F – Fixed orifice

5 Port size
0 – Cartridge only

CODE	PORT SIZE	HOUSING NUMBER	
		Aluminum Light duty	Aluminum Fatigue rated
12T	SAE 12	566152	–
6B	3/4" BSPP	02-175465	–
10H	SAE 10	–	876721
12H	SAE 12	–	876723
4G	1/2" BSPP	–	876720
6G	3/4" BSPP	–	876722

See section J for housing details.

6 Factory set flow rate,
(Specify in USgpm)
Range 1,9–114 L/min
(0.5–30 USgpm)

7 Special features
00 – None
(Only required if valve has
special features, omitted
if "00")



Dimensions

mm (inch)

Torque cartridge in
aluminum housing to
108–122 Nm (80–90 ft.lbs)

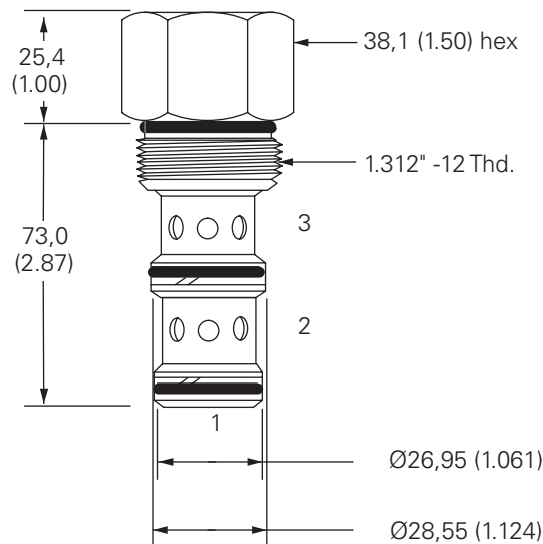

PFR2-10

Priority flow regulator, adjustable

Description

The PFR2-10 is a limited range adjustable*, pressure compensated, priority type, flow regulator screw-in cartridge valve.

*The flow adjustment is from the factory set maximum flow rate down to 50% of that factory set flow rate.

Functional Symbol

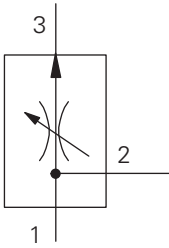

Sectional View

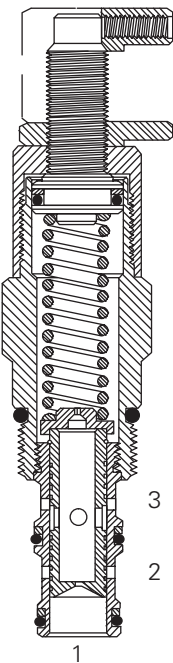

Operation

This valve maintains a constant, factory-set, priority flow from port 1 to port 3 based on the setting adjustment, regardless of pres-

sure changes downstream on port 3. Flow in excess of the priority setting is directed to port 2. If the priority flow at port 3 is blocked,

the spool will shift to satisfy the priority flow requirement, thereby closing off flow to port 2.

RATINGS AND SPECIFICATIONS

Performance data is typical with fluid at 21,8 cSt (105 SUS) and 49°C (120°F)

Typical application pressure (all ports)	210 bar (3000 psi)
Cartridge fatigue pressure (infinite life)	210 bar (3000 psi)
Rated flow	Maximum inlet flow 60 L/min (15 USgpm) Maximum regulated flow 38 L/min (10 USgpm)
Flow regulation accuracy	0,4–1,9 L/min (0.1–0.49 USgpm) ±20% 1,9–7,5 L/min (0.5–1.99 USgpm) ±15% 7,6–37,8 L/min (2.0–10.0 USgpm) ±10% <small>Factory set maximum priority flow rate accuracy under standard test conditions and within the above ranges</small>
Temperature range	-40° to 120°C (-40° to 248°F)
Cavity	C-10-3
Fluids	All general purpose hydraulic fluids such as: MIL-H-5606, SAE 10, SAE 20, etc.
Filtration	Cleanliness code 18/16/13
Standard housing materials	Aluminum
Weight cartridge only	0,25 kg (0.54 lb.)
Seal kits	565804 Buna-N 889599 Viton® <small>Viton is a registered trademark of E.I. DuPont</small>

Typical Flow Regulation

Cartridge only

A - Port 3, priority (regulated) outlet pressurized

B - Port 2, bypass outlet pressurized

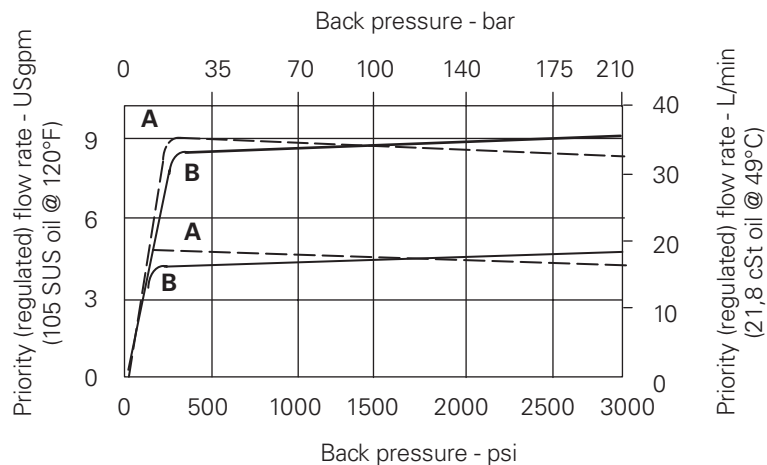

PFR2 - 10 (V) - * - ** - *. * - 00

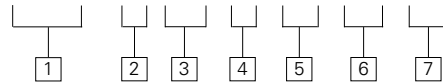

1 Function
PFR2 – Priority flow regulator

2 Size
10 – 10 Size

3 Seals
Blank – Buna-N
V – Viton®

4 Adjustment
C – Cap
K – Knob
S – Screw

5 Port size
0 – Cartridge only

CODE	PORT SIZE	HOUSING NUMBER	
		Aluminum Light duty	Aluminum Fatigue rated
3B	3/8" BSPP	02-173358	–
6T	SAE 6	566162	–
2G	1/4" BSPP	–	876705
3G	3/8" BSPP	–	876714
6H	SAE 6	–	876704
8H	SAE 8	–	876711

See section J for housing details.

6 Factory set flow rate, nominal
(Specify in USgpm) Range 0,38–37,8 L/min (0.1–10.0 USgpm)

7 Special features
00 – None
(Only required if valve has special features, omitted if "00")
SS - 316 Stainless Steel external components



Dimensions

mm (inch)

Torque cartridge in aluminum housing to 47–54 Nm (35–40 ft.lbs)

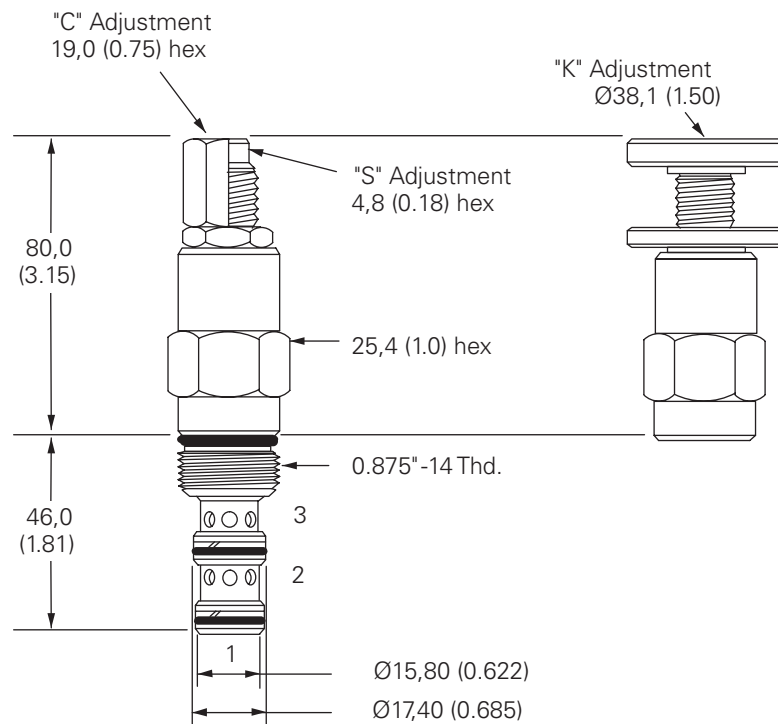

PFR2-16

Priority flow regulator, adjustable

Description

The PFR2-16 is a limited range adjustable*, priority type, pressure compensated, flow regulator screw-in cartridge valve.

*The flow adjustment is from the factory set maximum flow rate down to 50% of that factory set flow rate.

Functional Symbol

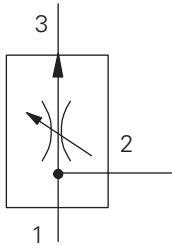

Sectional View

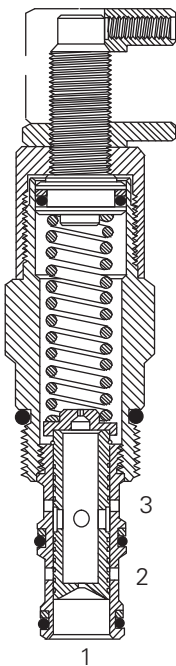

Operation

This valve maintains a constant, factory-set, priority flow from port 1 to port 3 based on the setting adjustment, regardless

of pressure changes downstream on port 3. Flow in excess of the priority setting is directed to port 2. If the priority flow at port 3 is

blocked, the spool will shift to satisfy the priority flow requirement, thereby closing off flow to port 2.

RATINGS AND SPECIFICATIONS

Performance data is typical with fluid at 21,8 cSt (105 SUS) and 49°C (120°F)

Typical application pressure (all ports)	210 bar (3000 psi)
Cartridge fatigue pressure (infinite life)	210 bar (3000 psi)
Rated flow	Maximum inlet flow 151 L/min (40 USgpm) Maximum regulated flow 114 L/min (30 USgpm)
Flow regulation accuracy	1,9–10,9 L/min (0,5–2,9 USgpm) ±15% 11,4–114 L/min (3–30 USgpm) ±10% <small>Factory set maximum priority flow rate accuracy under standard test conditions and within the above ranges</small>
Temperature range	-40° to 120°C (-40° to 248°F)
Cavity	C-16-3
Fluids	All general purpose hydraulic fluids such as: MIL-H-5606, SAE 10, SAE 20, etc.
Filtration	Cleanliness code 18/16/13
Standard housing materials	Aluminum
Weight cartridge only	0,43 kg (0.95 lb.)
Seal kits	565811 Buna-N 889610 Viton®

Viton is a registered trademark of E.I. DuPont

Typical Flow Regulation

Cartridge only

A – Port 3, priority (regulated) outlet pressurized

B – Port 2, bypass outlet pressurized

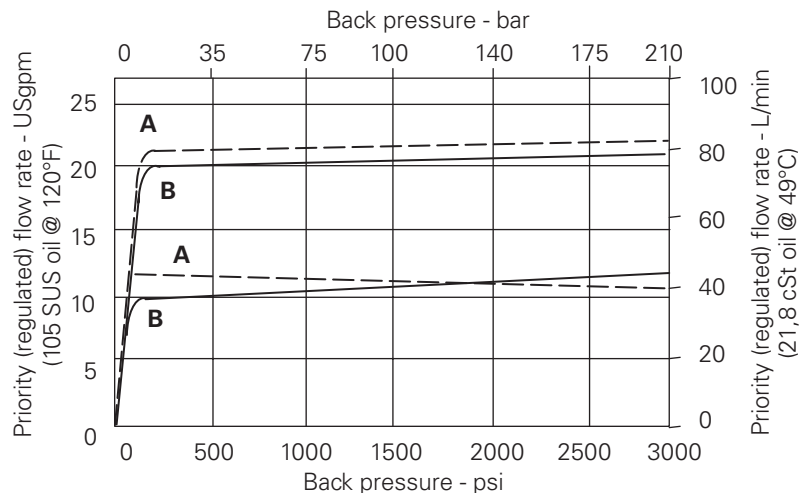

PFR2 - 16 (V) - * - * - * . * - 00**

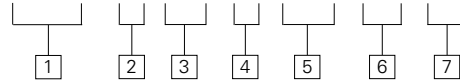

1 Function
PFR2 – Priority flow regulator

2 Size
16 – 16 Size

3 Seals
Blank – Buna-N
V – Viton®

4 Adjustment
C – Cap
K – Knob
S – Screw

5 Port size
0 – Cartridge only

CODE	PORT SIZE	HOUSING NUMBER	
		Aluminum Light duty	Aluminum Fatigue rated
12T	SAE 12	566152	–
6B	3/4" BSPP	02-175465	–
10H	SAE 10	–	876721
12H	SAE 12	–	876723
4G	1/2" BSPP	–	876720
6G	3/4" BSPP	–	876722

See section J for housing details.

6 Factory set flow rate,
(Specify in USgpm)
Range 1,9–114 L/min
(0.5–30 USgpm)

7 Special features
00 – None
(Only required if valve has special features, omitted if "00")
SS - 316 Stainless Steel external components



Dimensions

mm (inch)
Torque cartridge in aluminum housing to 108–122 Nm (80–90 ft.lbs)

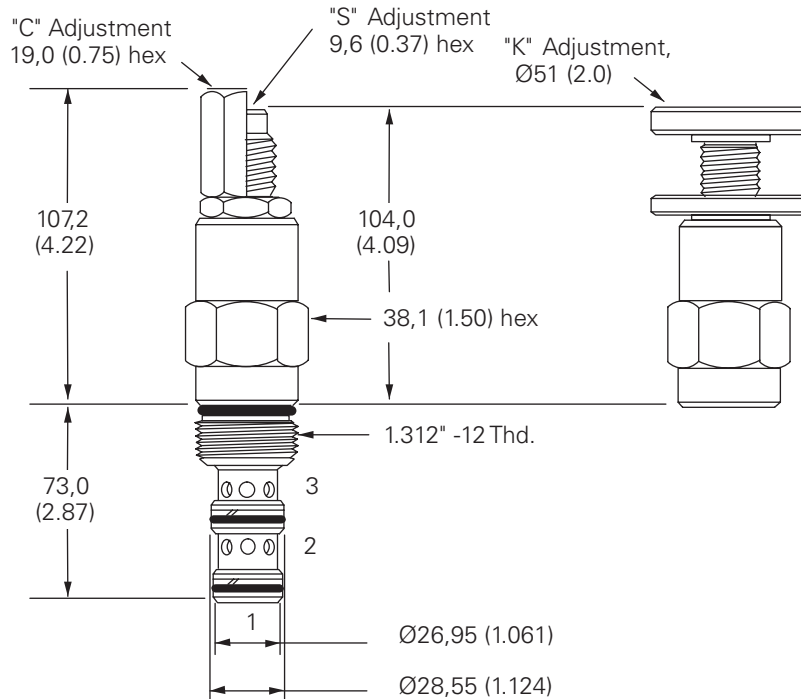

PFRD/S-12

Priority flow regulator valve

Description

The PFR*-12 is a spool type, screw-in, load-sensing priority flow regulator cartridge valve.

Functional Symbols

Dynamic Signal (PFRD)

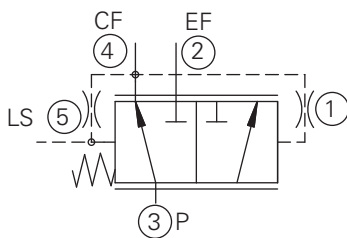

Static Signal (PFRS)

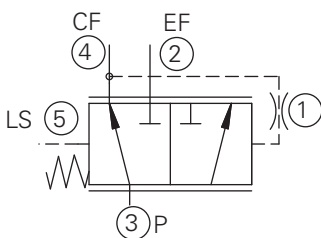

Profile View

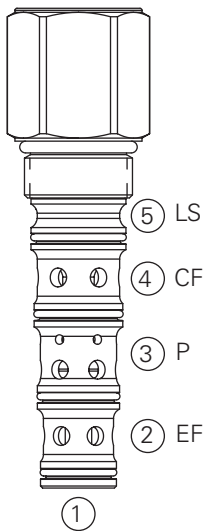

Note
Port 1 unused, port should be plugged.

Operation

This valve is used in the flow control mode. Pump flow from the valve inlet port 3 is delivered first to port 4 at a fixed rate; excess flow is bypassed to port 2. The valve maintains the controlled flow to 4 regardless of inlet pressure change or load pressure changes at 2 or 4. This valve is typically used with open loop load sense systems in steering and braking circuits. The static type

is used for less difficult applications where response or circuit stability is not a problem. The dynamic type is used for difficult applications where response or circuit stability are critical. The load sense line connected to port 5 should not exceed 2 Meters (6 Feet) in length. Overpressure protection for the circuits connected to ports 2 and 4 must be provided by external relief

valves. The control pressure is determined by assuring adequate inlet pressure to the steering unit and must be matched to the steering unit's required flow. The control pressure must be supplied to the valve as a minimum inlet pressure. The pressure at port 4 can vary by 10% when the load at the excess flow port 2 varies from 0 to maximum pressure.

RATINGS AND SPECIFICATIONS

Performance data is typical with fluid at 21,8 cSt (105 SUS) and 49°C (120°F)

Typical application pressure (all ports)	280 bar (4000 psi)
Cartridge fatigue pressure (infinite life)	280 bar (4000 psi)
Rated inlet flow	76 L/min (20 USgpm)
Temperature range	-40° to 120°C (-40° to 248°F)
Cavity	C-12-5S
Fluids	All general purpose hydraulic fluids such as: MIL-H-5606, SAE 10, SAE 20, etc.
Filtration	Cleanliness code 18/16/13
Housing materials	Aluminum or Steel
Weight cartridge only	0,36 kg (0.79 lb.)
Seal kit	202914-921
Internal leakage	164cc/min (10 in ³ /min) @ 3000 PSID
Recommended L/S orifice	0.031" (not included in valve)

Pressure Drop Curves

Cartridge only

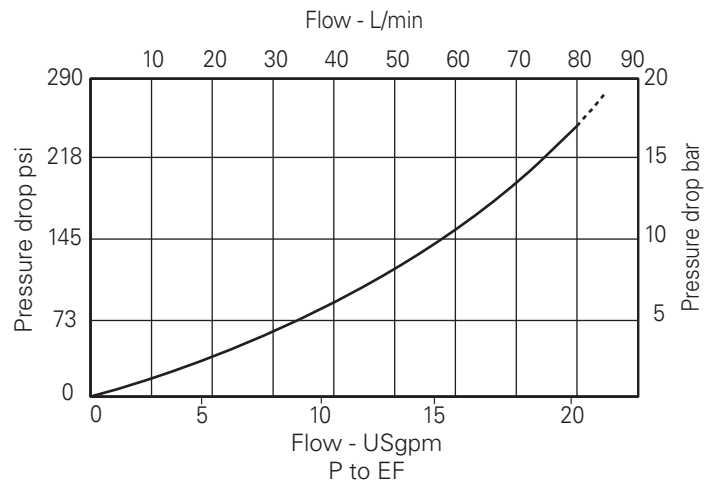

Notes
Minimum inlet flow should not be less than 1/4 of maximum inlet flow.

Minimum pressure drop is determined by control pressure.

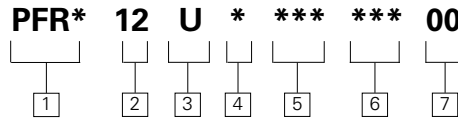

1 Function

PFRS – Priority flow regulator
 Static signal type
PFRD – Priority flow regulator
 Dynamic signal type

2 Size

12 – 12 Size

3 Seals

U– Urethane (standard)

4 Body

O – Cartridge only
A – Aluminum
S – Steel (standard)

5 Ports*

CODE	PORT SIZE		HOUSING NUMBER	
	Port 2, 3, 4	Port 5	Aluminum	Steel
000	No Body	–	–	–
10T	SAE 10	SAE 4	4998820-001	4998821-001
12T	SAE 12	SAE 4	4998820-002	4998821-002
04G	1/2" BSPP	1/4" BSPP	4998820-003	4998821-003
06G	3/4" BSPP	1/4" BSPP	4998820-004	4998821-004

*These model digits will not be stamped on the valve.
 See section J for housing details.

6 Control Pressure

PFRS options
 055 psi (3.8 bar)
 078 psi (5.4 bar)
 100 psi (6.9 bar)
PFRD options
 075 psi (5.2 bar)
 110 psi (7.6 bar)
 145 psi (10.0 bar)

7 Special features

00 – None
 (Only required if valve has special features, omitted if "00".)



Dimensions

mm (inch)

Torque cartridge in housing
A – 81-95 Nm (60–70 ft.lbs)
S – 102–115 Nm (75–85 ft.lbs)

Note
 Standard housings include port 1, however for most applications this port must be blocked.

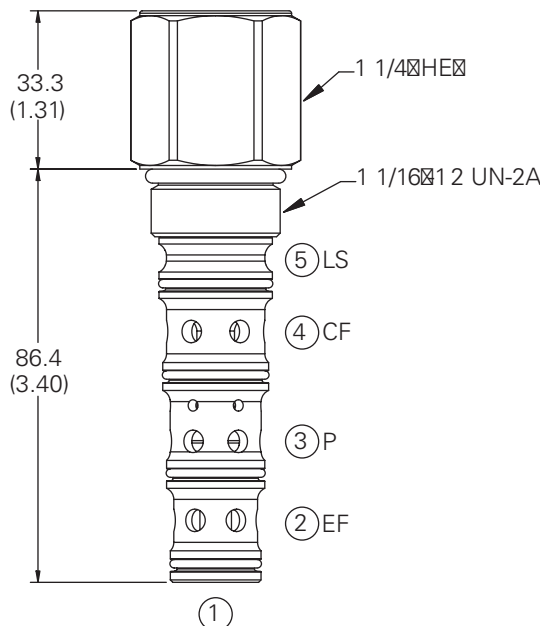

Aluminum housings can be used for pressures up to 210 bar (3000 psi)
 Steel housings **must** be used for operating pressures **above** 210 bar (3000 psi)

PFRD/S-16

Priority flow regulator valve

Description

The PFR*-16 is a spool type, screw-in, load-sensing priority flow regulator cartridge valve.

Functional Symbols

Dynamic Signal (PFRD)

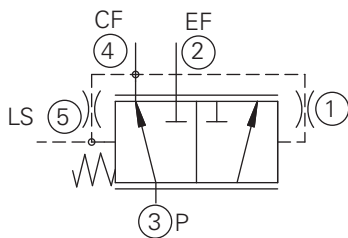

Static Signal (PFRS)

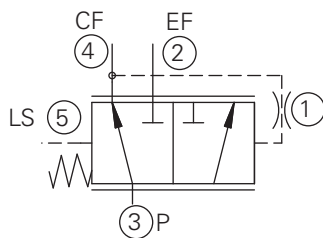

Profile View

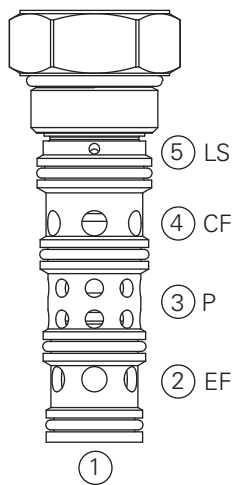

Note
Port 1 unused, port should be plugged.

Operation

This valve is used in the flow control mode. Pump flow from the valve inlet port 3 is delivered first to port 4 at a fixed rate; excess flow is bypassed to port 2. The valve maintains the controlled flow to 4 regardless of inlet pressure change or load pressure changes at 2 or 4. This valve is typically used with open loop load sense systems in steering and braking circuits. The static type

is used for less difficult applications where response or circuit stability is not a problem. The dynamic type is used for difficult applications where response or circuit stability are critical. The load sense line connected to port 5 should not exceed 2 Meters (6 Feet) in length. Overpressure protection for the circuits connected to ports 2 and 4 must be provided by external relief

valves. The control pressure is determined by assuring adequate inlet pressure to the steering unit and must be matched to the steering unit's required flow. The control pressure must be supplied to the valve as a minimum inlet pressure. The pressure at port 4 can vary by 10% when the load at the excess flow port 2 varies from 0 to max pressure.

RATINGS AND SPECIFICATIONS

Performance data is typical with fluid at 21,8 cSt (105 SUS) and 49°C (120°F)

Typical application pressure (all ports)	280 bar (4000 psi)
Cartridge fatigue pressure (infinite life)	280 bar (4000 psi)
Rated inlet flow	150 L/min (40 USgpm)
Temperature range	-40° to 100° C (-40° to 210° F)
Cavity	C-16-5S
Fluids	All general purpose hydraulic fluids such as: MIL-H-5606, SAE 10, SAE 20, etc.
Filtration	Cleanliness code 18/16/13
Housing materials (standard)	Steel
Weight cartridge only	0,47 kg (1.05 lbs.)
Seal kit	202915-922
Internal leakage	164cc/min (10 in ³ /min) @ 3000 PSID
Recommended L/S orifice	0.036" (not included in valve)

Pressure Drop Curves

Cartridge only

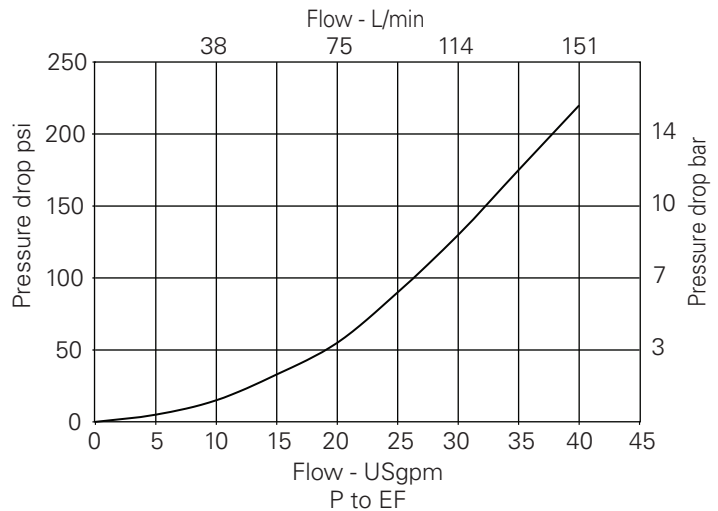

Notes
Minimum inlet flow should not be less than 1/4 of maximum inlet flow.

Minimum pressure drop is determined by control pressure.

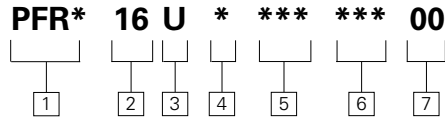

1 Function
PFRS – Priority flow regulator
 Static signal type
PFRD – Priority flow regulator
 Dynamic signal type

2 Size
16 – 16 Size

3 Seals
U– Urethane (standard)

4 Body
O – Cartridge only
A – Aluminum
S – Steel (standard)

5 Ports*

CODE	PORT SIZE		HOUSING NUMBER	
	Port 2, 3, 4	Port 5	Aluminum	Steel
000	No Body	–	–	–
12T	SAE 12	SAE 4	4994880-001	4994881-001
16T	SAE 16	SAE 4	4994880-002	4994881-002
06G	3/4" BSPP	1/4" BSPP	4994880-003	4994881-003
08G	1" BSPP	1/4" BSPP	4994880-004	4994881-004

*These model digits will not be stamped on the valve.
 See section J for housing details.

6 Control Pressure
PFRS options
 065 psi (4.5 bar)
 130 psi (8.9 bar)
 160 psi (11.0 bar)
PFRD options
 080 psi (5.5 bar)
 110 psi (7.6 bar)
 130 psi (9.0 bar)

7 Special features
00 – None
 (Only required if valve has special features, omitted if "00".)



Dimensions

mm (inch)

Torque cartridge in housing
A – 108-122 Nm (80-90 ft. lbs)
S – 136-149 Nm (100-110 ft. lbs)

Note
 Standard housings include port 1, however for most applications this port must be blocked.

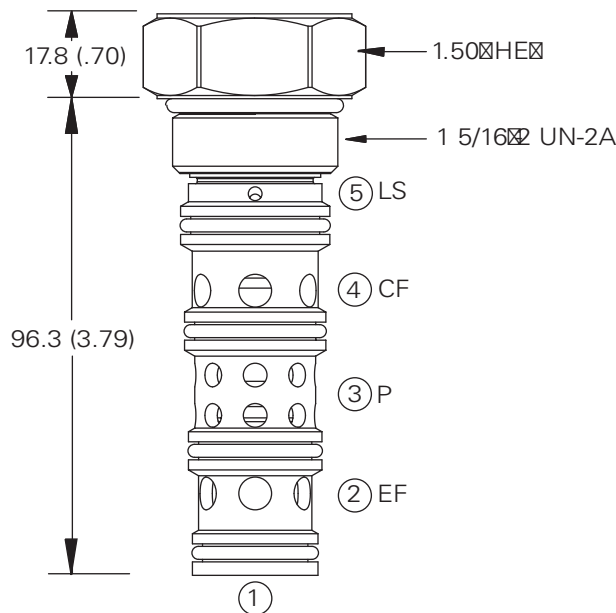

Aluminum housings can be used for pressures up to 210 bar (3000 psi)
 Steel housings **must** be used for operating pressures **above** 210 bar (3000 psi)

PFRD/S-20

Priority flow regulator valve

Description

The PFR*-20 is a spool type, screw-in, load-sensing priority flow regulator cartridge valve.

Functional Symbols

Dynamic Signal (PFRD)

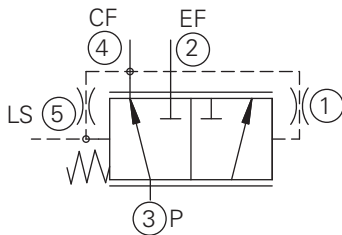

Static Signal (PFRS)

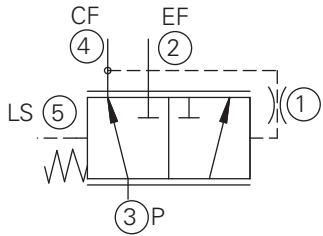

Profile View

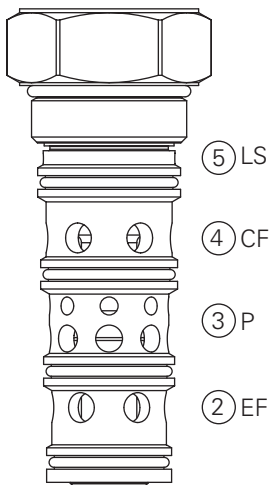

Note
Port 1 unused, port should be plugged.

Operation

This valve is used in the flow control mode. Pump flow from the valve inlet port 3 is delivered first to port 4 at a fixed rate; excess flow is bypassed to port 2. The valve maintains the controlled flow to 4 regardless of inlet pressure change or load pressure changes at 2 or 4. This valve is typically used with open loop load sense systems in steering and braking circuits. The static type

is used for less difficult applications where response or circuit stability is not a problem. The dynamic type is used for difficult applications where response or circuit stability are critical. The load sense line connected to port 5 should not exceed 2 Meters (6 Feet) in length. Overpressure protection for the circuits connected to ports 2 and 4 must be provided by external relief

valves. The control pressure is determined by assuring adequate inlet pressure to the steering unit and must be matched to the steering unit's required flow. The control pressure must be supplied to the valve as a minimum inlet pressure. The pressure at port 4 can vary by 10% when the load at the excess flow port 2 varies from 0 to max pressure.

RATINGS AND SPECIFICATIONS

Performance data is typical with fluid at 21,8 cSt (105 SUS) and 49°C (120°F)

Typical application pressure (all ports)	240 bar (3500 psi)
Cartridge fatigue pressure (infinite life)	240 bar (3500 psi)
Rated inlet flow	230 L/min (60 USgpm)
Temperature range	-40° to 100° C (-40° to 210° F)
Cavity	C-20-5S
Fluids	All general purpose hydraulic fluids such as: MIL-H-5606, SAE 10, SAE 20, etc.
Filtration	Cleanliness code 18/16/13
Housing materials (standard)	Steel
Weight cartridge only	0,86 kg (1.9 lbs.)
Seal kit	02-187543
Internal leakage	164 cc/min (10 in ³ /min) @ 3000 PSID
Recommended L/S orifice	0.047" (not included in valve)

Pressure Drop Curves

Cartridge only

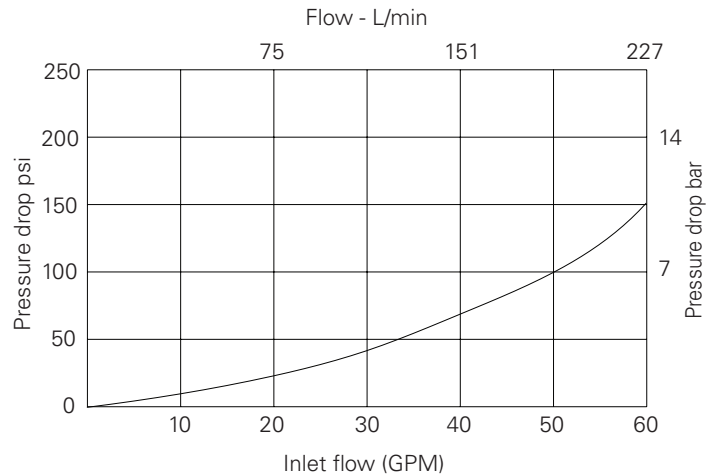

Note
Minimum inlet flow should not be less than 1/4 of maximum inlet flow.

Minimum pressure drop is determined by control pressure.

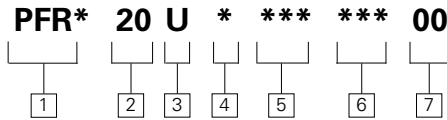

1 Function
PFRS – Priority flow regulator
 Static signal type
PFRD – Priority flow regulator
 Dynamic signal type

2 Size
 20 – 20 Size

3 Seals
 U– Urethane (standard)

4 Body
 O – Cartridge only
 A – Aluminum
 S – Steel (standard)

5 Ports*

CODE	PORT SIZE		HOUSING NUMBER	
	Port 2, 3, 4	Port 5	Aluminum	Steel
000	No Body	–	–	–
12T	SAE 12	SAE 4	4998822-001	4998823-001
16T	SAE 16	SAE 4	4998822-002	4998823-002
06G	3/4" BSPP	1/4" BSPP	4998822-003	4998823-003
08G	1" BSPP	1/4" BSPP	4998822-004	4998823-004

* These model digits will not be stamped on the valve.
 See section J for housing details.

6 Control Pressure
PFRS options
 080 psi (5.5 bar)
 100 psi (6.9 bar)
PFRD options
 085 psi (5.9 bar)
 110 psi (7.6 bar)

7 Special features
 00 – None
 (Only required if valve has special features, omitted if "00")



Dimensions

mm (inch)

Torque cartridge in housing
A – 130-155 Nm (95-115 ft. lbs)
S – 160-180 Nm (120-135 ft. lbs)

Note
 Standard housings include port 1, however for most applications this port must be blocked.

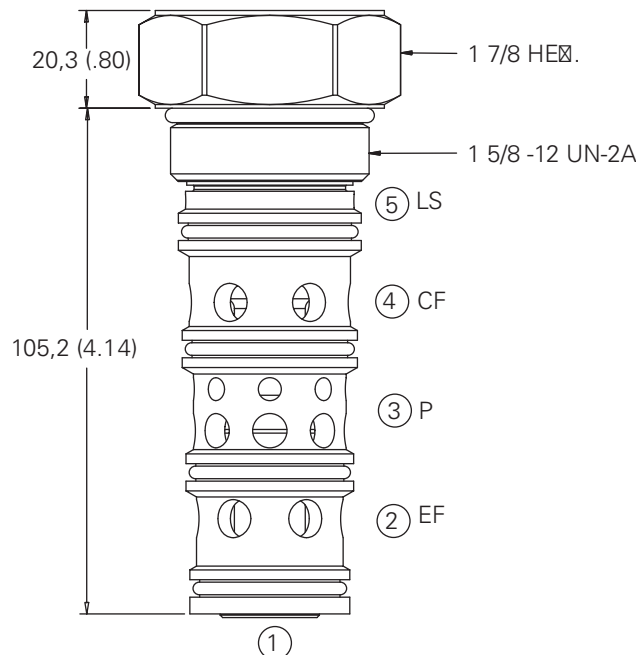

Aluminum housings can be used for pressures up to 210 bar (3000 psi)
 Steel housings **must** be used for operating pressures **above** 210 bar (3000 psi)

MRV2-10

Manual rotary flow control valve

Description

The MRV2-10 is a 2-way, 2 position, manual semi-rotary screw-in flow restrictor valve.

Functional Symbol

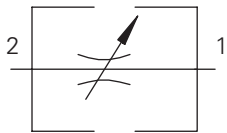

Sectional View

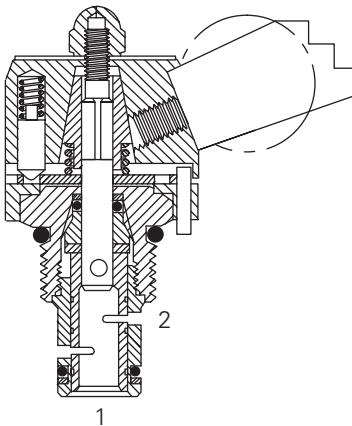

Operation

This valve will increase or decrease flow by changing the variable orifice with the rotary adjustment. Recommended flow path is 2 to 1.

RATINGS AND SPECIFICATIONS

Typical application pressure (all ports)	210 bar (3000 psi)
Rated flow	05 – 0-18,9 L/min (0-5 USgpm) 10 – 0-37,8 L/min (0-10 USgpm) 15 – 0-56,7 L/min (0-15 USgpm)
Internal leakage	164 cm ³ /min. (10 in ³ /min) maximum 210 bar (3000 psi)
Temperature range	-40° to 120°C (-40° to 248°F)
Manual operators	B – Ball lever (friction lock)* E – Ball lever (10 position detent)* D – Lever (10 position detent)* L – Lever (friction lock)* K – Knob (non-locking)
*Light duty housings only	
Cavity	C-10-2
Fluids	All general purpose hydraulic fluids such as: MIL-H-5606, SAE 10, SAE 20, etc.
Filtration	Cleanliness code 18/16/13
Standard housing materials	Aluminum
Weight cartridge only	0,79 kg (1.74 lb.)
Seal kits	561810 Buna-N 889609 Viton®

Viton is a registered trademark of E.I. DuPont

Pressure Drop Curve

Cartridge only
@ 5,5 bar (80 psi)
pressure drop

Rated flow
(See model code position 6)

- A - 05
- B - 10
- C - 15

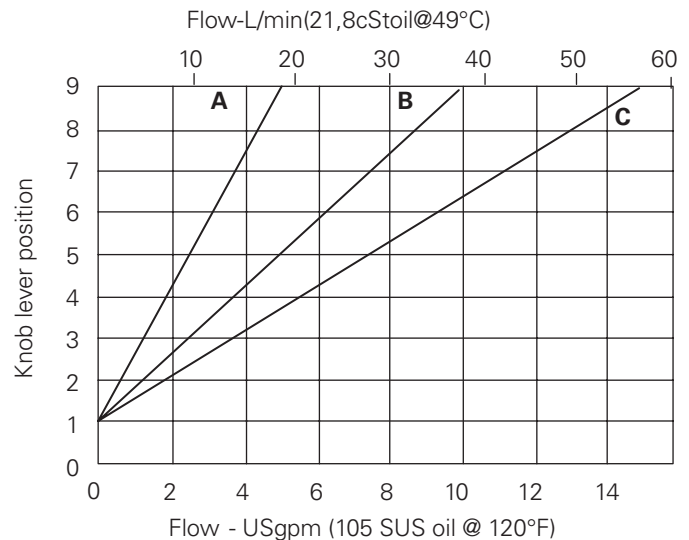

MRV2 – 10 (V) – * – ** – ** – 00

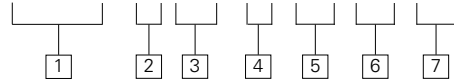

1 Function

MRV2 – Manual rotary valve

2 Size

10 – 10 Size

3 Seals

Blank – Buna-N
V – Viton®

4 Adjustment

0 – No operator
B – Ball lever (friction lock)*
E – Ball lever (10 position detent)*
D – Lever (10 position detent)*
L – Lever (friction lock)*
K – Knob (non-locking)
* Light duty housings only.

5 Port size

0 – Cartridge only

CODE	PORT SIZE	HOUSING NUMBER	
		Aluminum Light duty	Aluminum Fatigue rated
3B	3/8" BSPP	02-175462	–
6T	SAE 6	566151	–
2G	1/4" BSPP	–	876702
3G	3/8" BSPP	–	876703
6H	SAE 6	–	876700
8H	SAE 8	–	876701

See section J for housing details.

6 Max flow ranges (nominal)

05 – 0–18,9 L/min (0–5 USgpm)
10 – 0–37,8 L/min (0–10 USgpm)
15 – 0–56,7 L/min (0–15 USgpm)

7 Special features

00 – None
(Only required if valve has special features, omitted if "00")
SS – 316 Stainless Steel external components

Dimensions

mm (inch)

Torque cartridge in aluminum housing 47–54 Nm (35–40 ft.lbs)

MRV2-10-K Knob Operated

Arrow can be re-located by slacking the plate. Re-tighten nut.

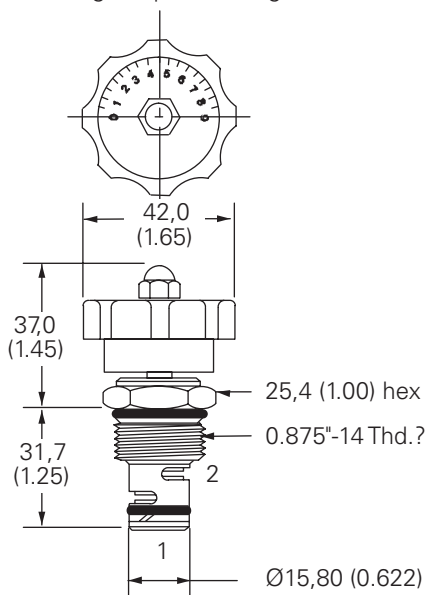

MRV2-10-B/E Models

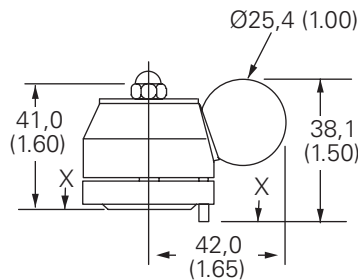

MRV2-10-D/L Models

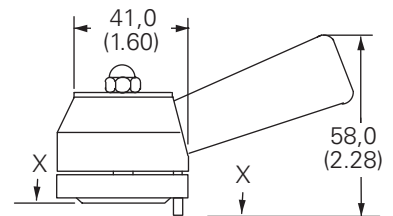

MRV2-10-E/D Models

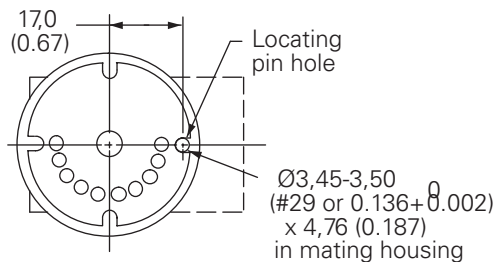

MRV2-10-B/L Models

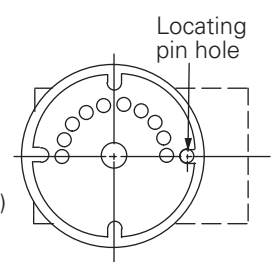

MRV2-16

Manual rotary valve

Description

The MRV2-16 is a 2-way, 2 position, manual semi-rotary screw-in flow restrictor valve.

Operation

This valve will increase or decrease flow by changing the variable orifice with the rotary adjustment.

Recommended flow path is 2 to 1.

Functional Symbol

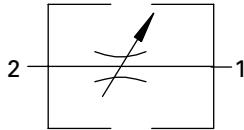

Sectional View

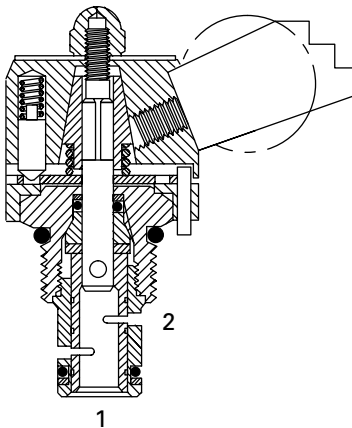

RATINGS AND SPECIFICATIONS

Performance data is typical with fluid at 21,8 cSt (105 SUS) and 49°C (120°F)

Typical application pressure (all ports)		210 bar (3000 psi)
Rated flow	10 – 0-37,8 L/min (0-10 USgpm)	30 – 0-113,5 L/min (0-30 USgpm)
	15 – 0-56,7 L/min (0-15 USgpm)	35 – 0-132,4 L/min (0-35 USgpm)
	20 – 0-75,7 L/min (0-20 USgpm)	40 – 0-151,4 L/min (0-40 USgpm)
	25 – 0-94,6 L/min (0-25 USgpm)	45 – 0-170,3 L/min (0-45 USgpm)
Internal leakage		82 cm ³ /min. (5 in ³ /min maximum 210 bar (3000 psi)
Temperature range		-40° to 120°C (-40° to 248°F)
Manual operators		D – Lever (10 position detent) L – Lever (friction lock) K – Knob (non-locking) Light duty housings only
Cavity		C-16-2
Fluids		All general purpose hydraulic fluids such as: MIL-H-5606, SAE 10, SAE 20, etc.
Filtration		Cleanliness code 18/16/13
Standard housing materials		Aluminum
Weight cartridge only		0,79 kg (1.74 lb.)
Seal kits		565810 Buna-N 889609 Viton® Viton is a registered trademark of E.I. DuPont

Pressure Drop Curve

Cartridge only
@ 5,5 bar (80 psi)
pressure drop

Rated flow
(See model code position 6)

A - 10 E - 30
B - 15 F - 35
C - 20 G - 40
D - 25 H - 45

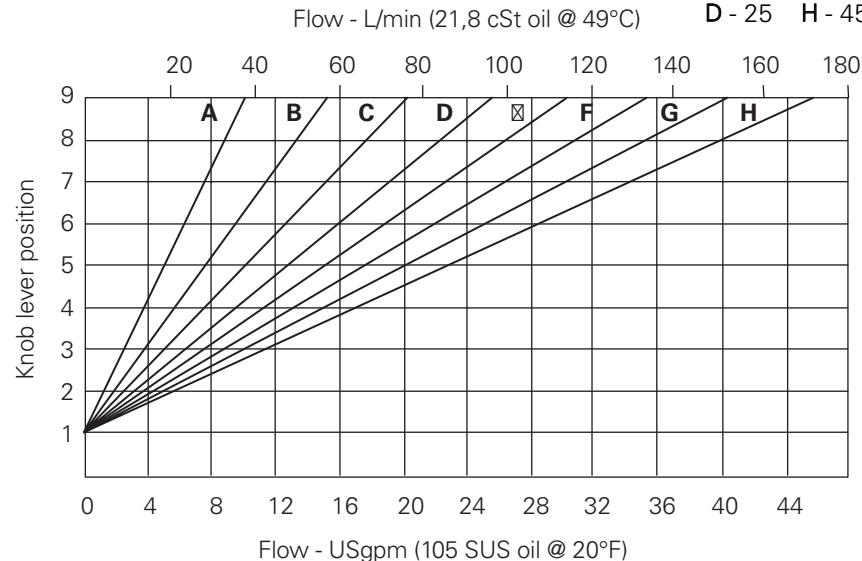

MRV2-16 (V) - * - * - ** - 00**

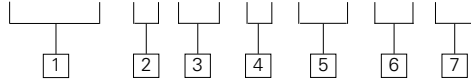

1 Function

MRV2 – Manual rotary valve

2 Size

16 – 16 Size

3 Seals

Blank – Buna-N
V – Viton®

4 Adjustment

0 – No operator
D – Lever (10 position detent)*
L – Lever (friction lock)*
K – Knob (non-locking)
* Light duty housings only.

5 Port size

0 – Cartridge only

CODE	PORT SIZE	HOUSING NUMBER	
		Aluminum Light duty	Aluminum Fatigue rated
6B	3/4" BSPP	02-175463	–
12T	SAE 12	566149	–
4G	1/2" BSPP	–	876716
6G	3/4" BSPP	–	876718
10H	SAE 10	–	876717
12H	SAE 12	–	566113

See section J for housing details.

6 Max flow ranges (nominal)

- 10 – 0-37,8 L/min (0-10 USgpm)
- 15 – 0-56,7 L/min (0-15 USgpm)
- 20 – 0-75,7 L/min (0-20 USgpm)
- 25 – 0-94,6 L/min (0-25 USgpm)
- 30 – 0-113,5 L/min (0-30 USgpm)
- 35 – 0-132,4 L/min (0-35 USgpm)
- 40 – 0-151,4 L/min (0-40 USgpm)
- 45 – 0-170,3 L/min (0-45 USgpm)

7 Special features

00 – None
(Only required if valve has special features, omitted if "00".)

Dimensions

mm (inch)

Torque cartridge in aluminum housing 108–122 Nm (80–90 ft.lbs)

MRV2-16-K Knob Operated

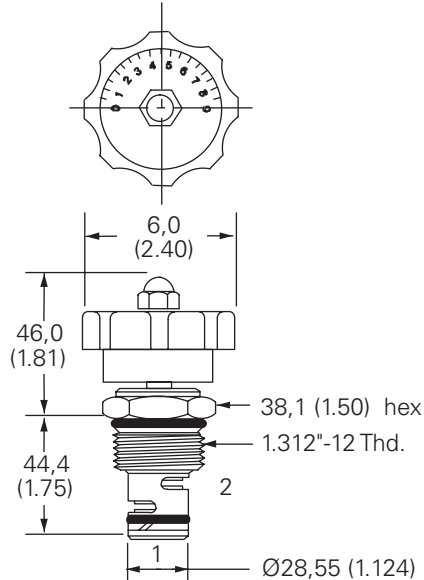

MRV2-16-D/L Models

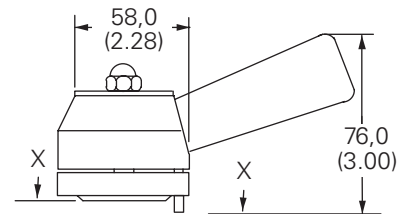

MRV2-16-D Models

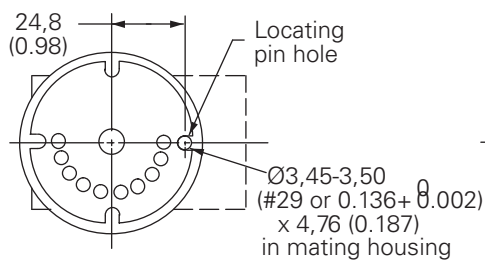

MRV2-16-L Models

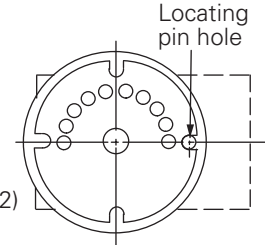

NV1-8

Needle valve

Description

The NV1-8 is a direct-acting, adjustable, screw-in cartridge type needle valve.

Operation

This needle valve is non-pressure compensated. Flow is controlled in either direction, from full flow to tight shut-off, by turning the adjustment feature clockwise.

Functional Symbol

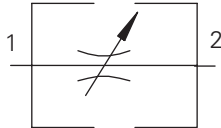

Sectional View

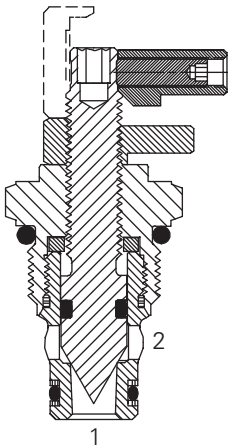

RATINGS AND SPECIFICATIONS

Performance data is typical with fluid at 21,8 cSt (105 SUS) and 49°C (120°F)

Typical application pressure (all ports)	350 bar (5000 psi) steel housing 210 bar (3000 psi) aluminum housing
Cartridge fatigue pressure (infinite life)	280 bar (4000 psi)
Rated flow	45 L/min (12 USgpm)
Internal leakage	5 drops/min. maximum @ 350 bar (5000 psi)
Temperature range	-40° to 120°C (-40° to 248°F)
Cavity	C-8-2
Fluids	All general purpose hydraulic fluids such as: MIL-H-5606, SAE 10, SAE 20, etc.
Filtration	Cleanliness code 18/16/13
Standard housing materials	Aluminum or steel
Weight cartridge only	0,07 kg. (0.15 lbs.)
Seal Kits	02-165875 Buna-N 02-165877 Viton®

Viton is a registered trademark of E.I. DuPont

Pressure Drop Curve

Cartridge only

Full open
Port 1 to port 2
or port 2 to port 1.

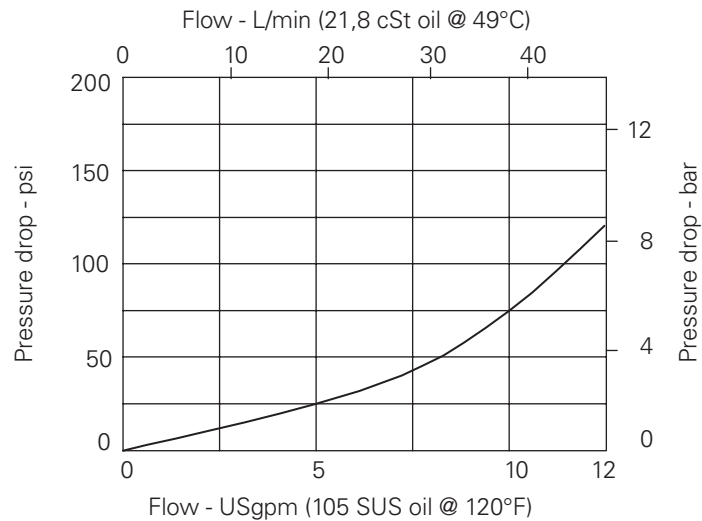

NV1-8 (V) - * - (*) - ** - 00

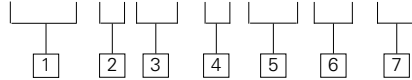

- 1 Function**
NV1 – Needle valve

- 2 Size**
8 – 8 Size

- 3 Seals**
Blank– Buna-N
V – Viton®

- 4 Style**
S – Screw
C – Cap
K – Knob

6 Port size
0 – Cartridge only

CODE	PORT SIZE	HOUSING NUMBER	
		Aluminum Fatigue rated	Steel Fatigue rated
4T	SAE 4	02-160730	02-160736
6T	SAE 6	02-160731	02-160737
8T	SAE 8	02-160732	02-160738
2G	1/4" BSPP	02-160727	02-160733
3G	3/8" BSPP	02-160728	02-160734

7 Special features
00 – None
(Only required if valve has special features, omitted if "00")

See section J for housing details.

- 5 Valve housing material**
Omit for cartridge only
S – Steel
A – Aluminum

Dimensions
mm (inch)
Torque cartridge in aluminum or steel housing to 34–41 Nm (25–30 ft.lbs)

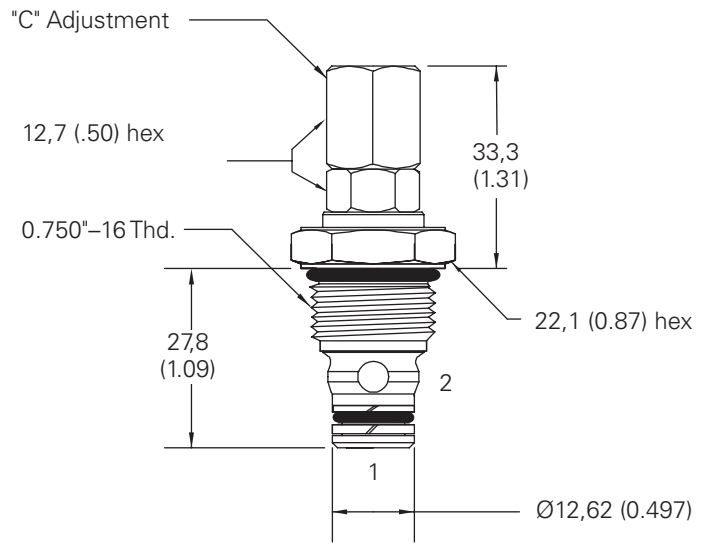

 Aluminum housings can be used for pressures up to 210 bar (3000 psi). Steel housings **must** be used for operating pressures **above** 210 bar (3000 psi).



NV1-10

Needle valve

Description

The NV1-10 is a direct-acting, adjustable, screw-in cartridge type needle valve.

Operation

This needle valve is non-pressure compensated. Flow is controlled in either direction, from full flow to tight shut-off, by turning the adjustment feature clockwise.

Functional Symbol

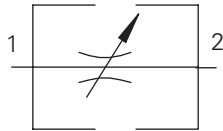

RATINGS AND SPECIFICATIONS

Performance data is typical with fluid at 21,8 cSt (105 SUS) and 49°C (120°F)

Typical application pressure (all ports)	210 bar (3000 psi)
Cartridge fatigue pressure (infinite life)	210 bar (3000 psi)
Rated flow	45 L/min (12 USgpm)
Internal leakage	5 drops/min. maximum @ 210 bar (3000 psi)
Temperature range	-40° to 120°C (-40° to 248°F)
Cavity	C-10-2
Fluids	All general purpose hydraulic fluids such as: MIL-H-5606, SAE 10, SAE 20, etc.
Filtration	Cleanliness code 18/16/13
Standard housing materials	Aluminum
Weight cartridge only	0,11 kg. (0.24 lbs.)
Seal Kits	565806 Buna-N 889627 Viton®

Viton is a registered trademark of E.I. DuPont

Sectional View

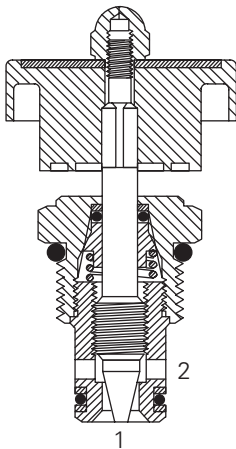

Pressure Drop Curve

Cartridge only

Fully open port 1 to port 2
or port 2 to port 1

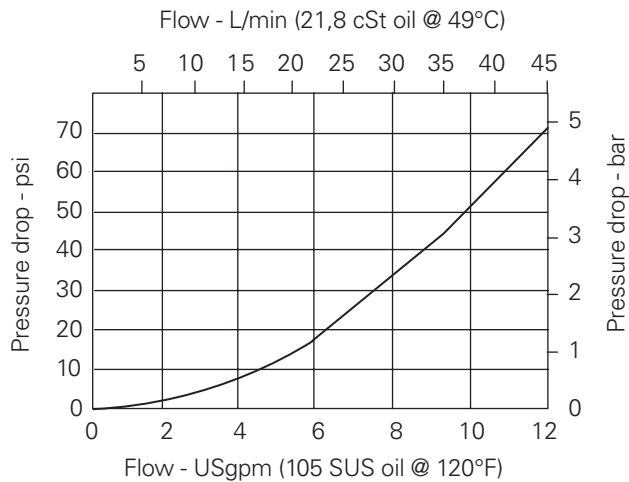

NV1-10 (V)-*--00**

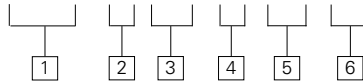

1 Function

NV1 – Needle valve

2 Size

10 – 10 Size

3 Seals

Blank – Buna-N
V – Viton®

4 Style

K – Knob (black)
R – Knob (red)

5 Port size

0 – Cartridge only

CODE	PORT SIZE	HOUSING NUMBER	
		Aluminum Light duty	Aluminum Fatigue rated
3B	3/8" BSPP	02-175462	–
6T	SAE 6	566151	–
2G	1/4" BSPP	–	876702
3G	3/8" BSPP	–	876703
6H	SAE 6	–	876700
3G	SAE 8	–	876701

See section J for housing details.

6 Special features

00 – None
(Only required if valve has special features, omitted if "00")

Dimensions

mm (inch)

Torque cartridge in aluminum housing
47–54 Nm (35–40 ft.lbs)

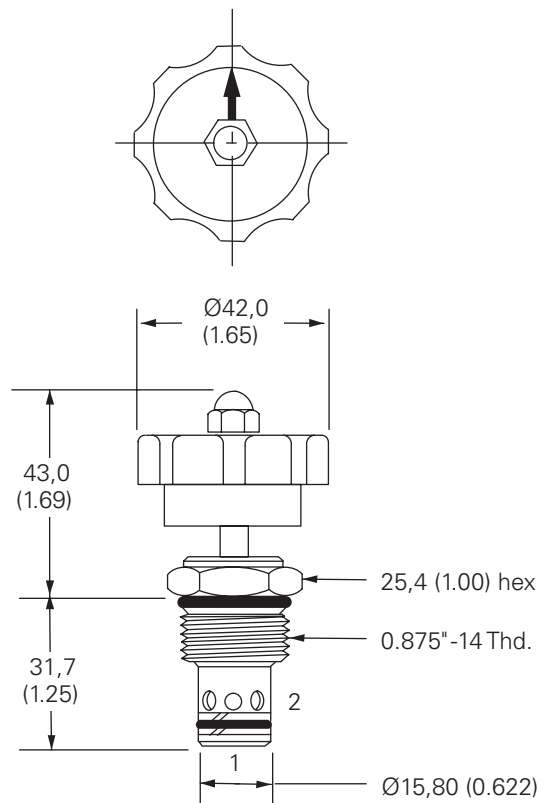

NV1-16

Needle valve

Description

The NV1-16 is a direct-acting, adjustable, screw-in cartridge type needle valve.

Functional Symbol

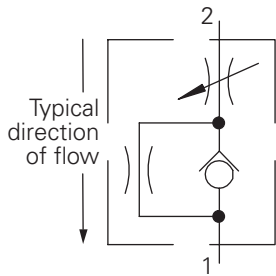

Sectional View

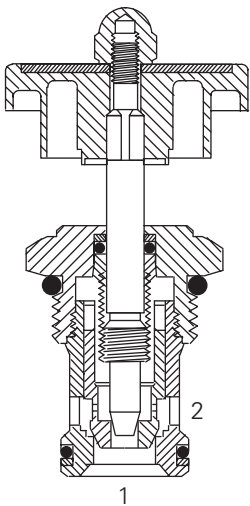

Application Note

The valve is not intended for use at low flows, may chatter below 10 L/min (2.5 gpm)

Operation

This needle valve is non-pressure compensated. Flow is controlled in the direction from port 2 to port 1, from full flow to

tight shut-off, by turning the adjustment feature clockwise. The flow from port 1 to port 2 will be restricted.

RATINGS AND SPECIFICATIONS

Performance data is typical with fluid at 21,8 cSt (105 SUS) and 49°C (120°F)

Typical application pressure (all ports)	210 bar (3000 psi)
Cartridge fatigue pressure (infinite life)	210 bar (3000 psi)
Rated flow	151 L/min (40 USgpm)
Internal leakage	5 drops/min. maximum @ 210 bar (3000 psi)
Temperature range	-40° to 120°C (-40° to 248°F)
Cavity	C-16-2
Fluids	All general purpose hydraulic fluids such as: MIL-H-5606, SAE 10, SAE 20, etc.
Filtration	Cleanliness code 18/16/13
Standard housing materials	Aluminum
Weight cartridge only	0,34 kg. (0.76 lbs.)
Seal kits	565810 Buna-N 889609 Viton®

Viton is a registered trademark of E.I. DuPont

Pressure Drop Curve

Cartridge only

Full open port 2 to port 1

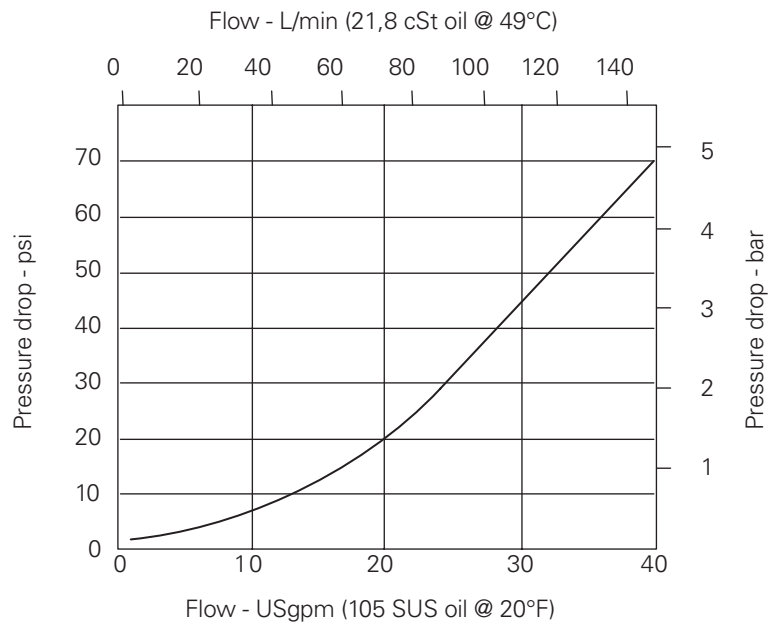

NV1-16 (V)-K-*-00**

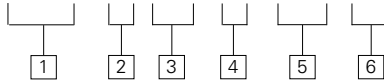

1 Function
NV1 – Needle valve

2 Size
16 – 16 Size

3 Seals
Blank– Buna-N
V – Viton®

4 Style
K – Knob (black)
R – Knob (red)

5 Port size
0 – Cartridge only

CODE	PORT SIZE	HOUSING NUMBER	
		Aluminum Light duty	Aluminum Fatigue rated
6B	3/4" BSPP	02-175463	–
12T	SAE 12	566149	–
4G	1/2" BSPP	–	876716
6G	3/4" BSPP	–	876718
10H	SAE 10	–	876717
12G	SAE 12	–	566113

See section J for housing details.

6 Special features
00 – None
(Only required if valve has special features, omitted if "00".)



Dimensions

mm (inch)

Torque cartridge in aluminum housing
108–122 Nm (80–90 ft.lbs)

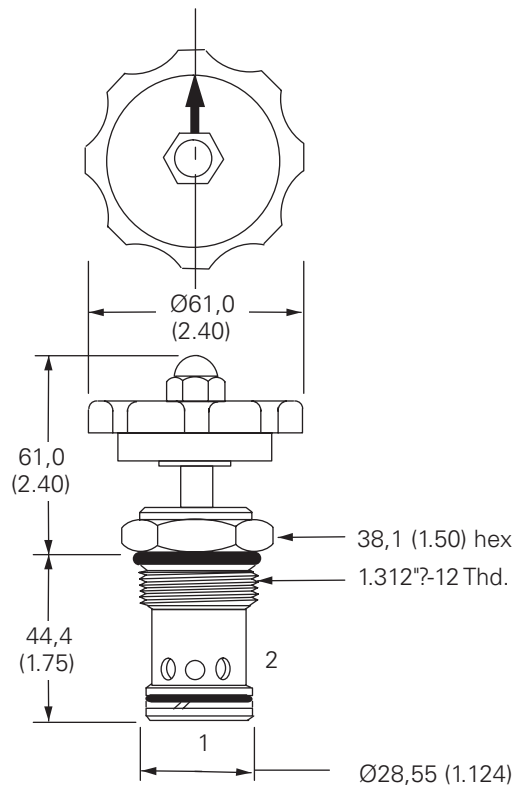

NV1-20

Needle valve

Description

The NV1-20 is a direct-acting, adjustable, screw-in cartridge type needle valve.

Functional Symbol

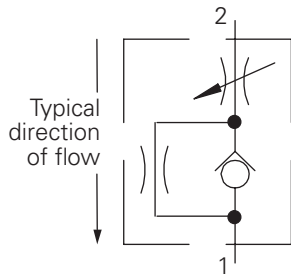

Sectional View

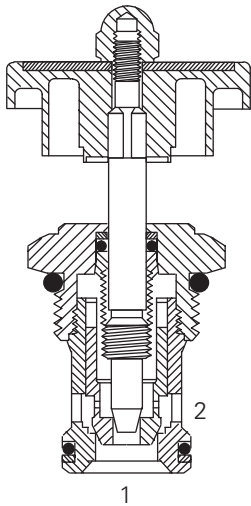

Application Note

The valve is not intended for use at low flows, may chatter below 10 L/min (2.5 gpm)

Operation

This needle valve is non-pressure compensated. Flow is controlled in the direction from port 2 to port 1, from full flow to

tight shut-off, by turning the adjustment feature clockwise. The flow from port 1 to port 2 will be restricted.

RATINGS AND SPECIFICATIONS

Performance data is typical with fluid at 21,8 cSt (105 SUS) and 49°C (120°F)

Typical application pressure (all ports)	210 bar (3000 psi)
Cartridge fatigue pressure (infinite life)	210 bar (3000 psi)
Rated flow	265 L/min (70 USgpm)
Internal leakage	5 drops/min. maximum @ 210 bar (3000 psi)
Temperature range	-40° to 120°C (-40° to 248°F)
Cavity	C-20-2
Fluids	All general purpose hydraulic fluids such as MIL-H-5606, SAE 10, SAE 20, etc.
Filtration	Cleanliness code 18/16/13
Standard housing materials	Aluminum
Weight cartridge only	0,59 kg. (1.3 lbs.)
Seal kits	889615 Buna-N 889619 Viton®

Viton is a registered trademark of E.I. DuPont

Pressure Drop Curve

Cartridge only

Full open port 2 to port 1.

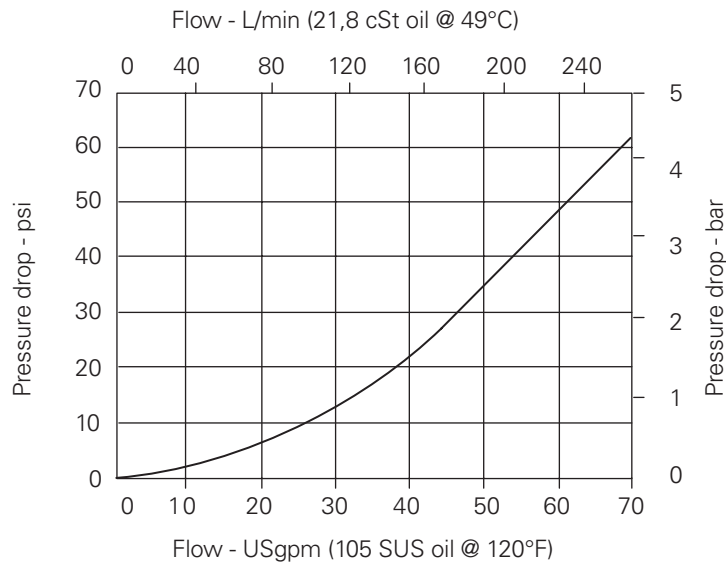

NV1-20 (V) - * - * - 00**

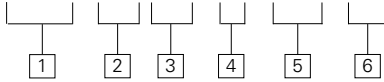

1 Function
 NV1 – Needle valve

2 Size
 20 – 20 Size

3 Seals
 Blank – Buna-N
 V – Viton®

4 Style
 K – Knob (black)
 R – Knob (red)

5 Port size
 0 – Cartridge only

CODE	PORT SIZE	HOUSING NUMBER	
		Aluminum Light duty	Aluminum Fatigue rated
8B	1" BSPP	02-175464	–
16T	SAE 16	566409	–
6G	3/4" BSPP	–	876732
8G	1" BSPP	–	876734
12H	SAE 12	–	876733
16H	SAE 16	–	876735

See section J for housing details.

6 Special features
 00 – None
 (Only required if valve has special features, omitted if "00")



Dimensions

mm (inch)

Torque cartridge in aluminum housing
 128–155 Nm (95–115 ft.lbs)

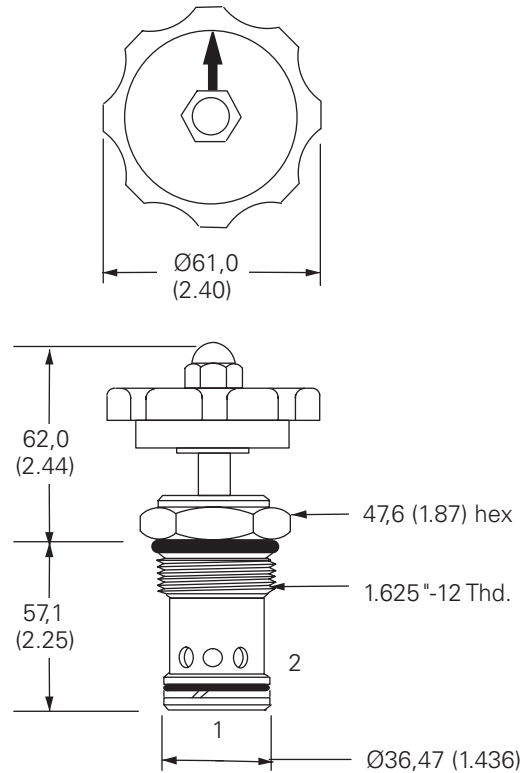

FCV7-10

Flow control valve

Description

The FCV7-10 is a non-pressure compensated, adjustable, flow restrictor available with and without free-flow check.

Operation

This valve when applied without the free flow check will allow flow between ports 1 and 2 through an increasing variable orifice when the adjustment is

turned counterclockwise. In the full clockwise position this valve provides tight shut-off. When applied with the free flow check, the valve will work as stated

above allowing flow between port 2 and port 1, while it allows free reverse from port 1 to port 2.

Functional Symbols

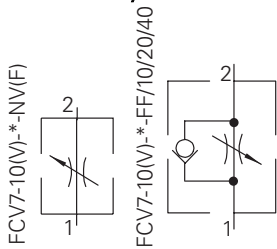

Sectional Views

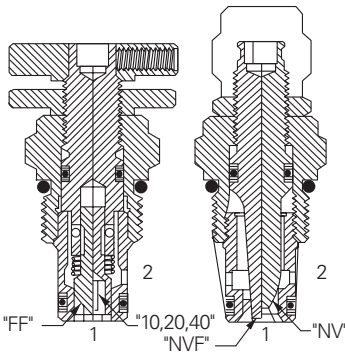

RATINGS AND SPECIFICATIONS

Performance data is typical with fluid at 21,8 cSt (105 SUS) and 49°C (120°F)

Typical application pressure (all ports)	210 bar (3000 psi)
Rated flow	45 L/min (12 USgpm)
Temperature range	-40° to 120°C (-40° to 248°F)
Cavity	C-10-2
Fluids	All general purpose hydraulic fluids such as: MIL-H-5606, SAE 10, SAE 20, etc.
Filtration	ISO 4406, class 18/16/13 or cleaner
Standard housing materials	Aluminum
Weight cartridge only	0,11 kg (0.25 lbs.)
Seal kits	565806 Buna N 889627 Viton®

Viton is a registered trademark of E.I. DuPont

Pressure Drop Curve

Cartridge only

Typical Flow Regulation (full open)

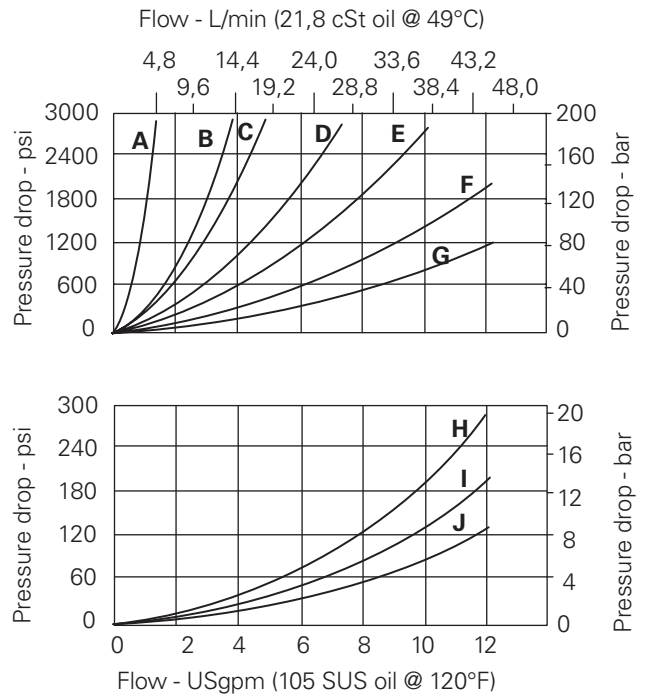

CURVE	CODE OPTION*	FLOW, DIRECTION, PORT:	VALVE CONDITION
A	10	2 to 1 1 to 2	Open Closed
B	20	2 to 1 1 to 2	Open Closed
C	10	1 to 2	Open
D	40	2 to 1 1 to 2	Open Closed
E	NVF	Both directions	Open
F	20	1 to 2	Open
G	40	1 to 2	Open
H	FF	2 to 1	Open
I	FF	1 to 2	Open & closed
J	NV	Both directions	Open

*See controlled flow option in model code.

FCV7 – 10 (V) – * – ** – * – 00**

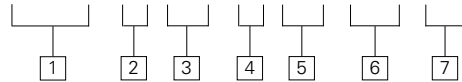

1 Function
FCV7 – Flow regulator

2 Size
10 – 10 Size

3 Seals
Blank – Buna-N
V – Viton®

4 Style
C – Cap
K – Knob
S – Screw

5 Port size
0 – Cartridge only

CODE	PORT SIZE	HOUSING NUMBER	
		Aluminum Light duty	Aluminum Fatigue rated
3B	3/8" BSPP	02-175462	–
6T	SAE 6	566151	–
2G	1/4" BSPP	–	876702
3G	3/8" BSPP	–	876703
6H	SAE 6	–	876700
8H	SAE 8	–	876701

See section J for housing details.

6 Special features
00 – None
(Only required if valve has special features, omitted if "00")

6	CONTROLLED FLOW OPTION	MAXIMUM FLOW RANGE (NOMINAL)
NV	Needle valve	0-45 L/min (0-12 USgpm)
NVF	Needle valve, fine	0-38 L/min (0-10 USgpm)
FF	Needle valve with free reverse flow	0-45 L/min (0-12 USgpm)
10	Flow range, type 10, with free reverse flow	0-6,6 L/min (0-1.75 USgpm)
20	Flow range, type 20, with free reverse flow	0-14 L/min (0-3.75 USgpm)
40	Flow range, type 40, with free reverse flow	0-27 L/min (0-7.25 USgpm)

Dimensions

mm (inch)

Torque cartridge in aluminum housing to 47-54 Nm (35-40 ft.lbs)

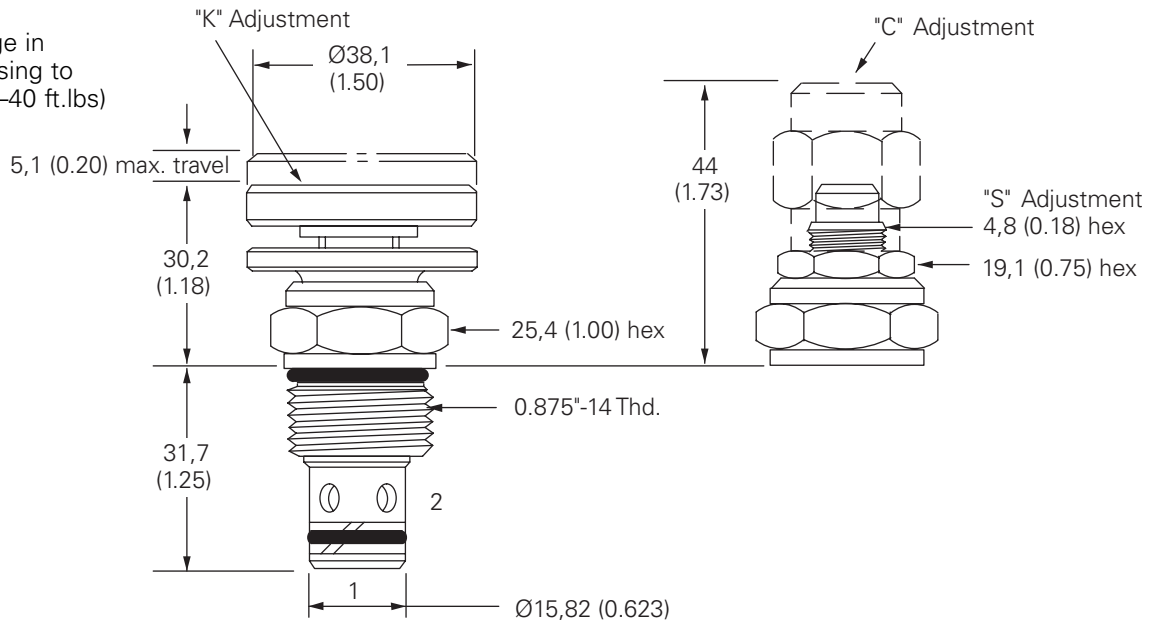

FCV11-12

Flow control valve

Description

The FCV11-12 is a direct acting, adjustable needle valve.

Operation

This valve is non-pressure compensated. Flow is controlled in either direction, from full flow to tight shut off, by turning the adjustment feature clockwise.

Functional Symbol

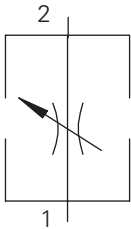

RATINGS AND SPECIFICATIONS

Performance data is typical with fluid at 21,8 cSt (105 SUS) and 49°C (120°F)

Typical application pressure	350 bar (5000 psi) Port "1" to "2" 210 bar (3000 psi) Port "1" to "2"
Cartridge fatigue pressure (infinite life)	350 bar (5000 psi)
Rated flow	114 L/min (30 USgpm)
Internal leakage	less than 5 drops / min. max. @210 bar (3000 psi)
Temperature range	-40° to 120°C (-40° to 248°F)
Cavity	C-12-2 or C-12-2U
Fluids	All general purpose hydraulic fluids such as: MIL-H-5606, SAE 10, SAE 20, etc.
Filtration	Cleanliness code 18/16/13
Standard housing materials	Aluminum or steel
Weight cartridge only	0,24 kg (0.54 lb.)
Seal kit	02-165889 Buna-N 02-165888 Viton®

Viton is a registered trademark of E.I. DuPont

Sectional View

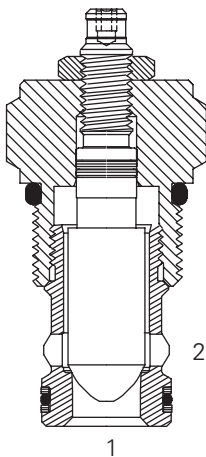

Pressure Drop Curve

Cartridge only

- A – Cartridge with C-12-2 valve body, full open
- B – Cartridge with C-12-2U valve body, full open
- C – Cartridge only, full open

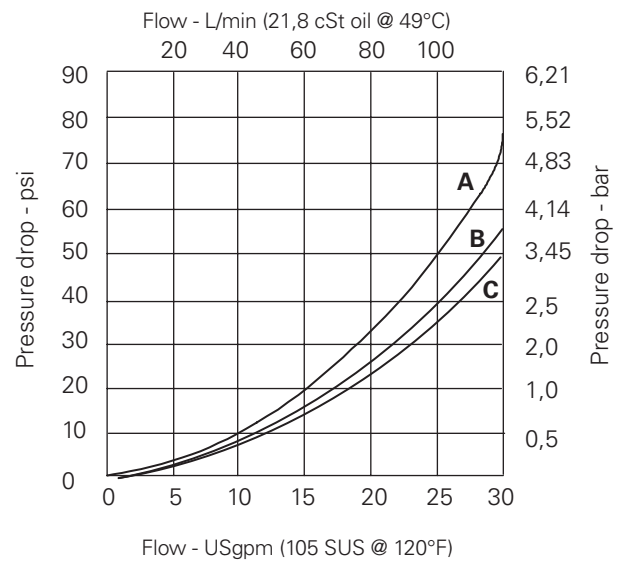

FCV11-12 (V)-S-*-*-(U)-NV-00**

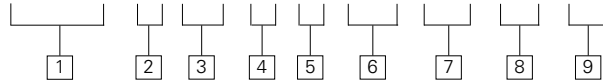

1 Function
FCV11 – Flow control valve

2 Size
12 – 12 Size

3 Seals
Blank – Buna-N
V – Viton®

4 Adjustment
S – Screw
K – Knob

5 Valve housing material
Blank – No body
S – Steel
A – Aluminum

Dimensions

mm (inch)

Torque cartridge in housing
A – 81–95 Nm (60–70 ft.lbs)
S – 102–115 Nm (75–85 ft.lbs)

6 Port size
0 – Cartridge only

CODE	PORT SIZE	HOUSING NUMBER			
		C-12-2U Aluminum Fatigue rated	C-12-2 Aluminum Fatigue rated	C-12-2U Steel Fatigue rated	C-12-2 Steel Fatigue rated
10T(U)	SAE 10	02-160641	02-160640	02-169817	02-169744
12T(U)	SAE 12	02-160645	02-160644	02v169790	02-169782
4G(U)	1/2" BSPP	02-161116	02-161118	02-172512	02-172062
6G(U)	3/4" BSPP	02-161115	02-161117	02-162922	02-169665

See section J for housing details.
Note: C-12-2U housings have undercut for improved flow.

7 Cavity
Blank – Cavity without undercut
U – Cavity with undercut

8 Valve type
NV – Needle Valve (Adjustable)

9 Special features
00 – None
(Only required if valve has special features, omitted if "00") housings can be

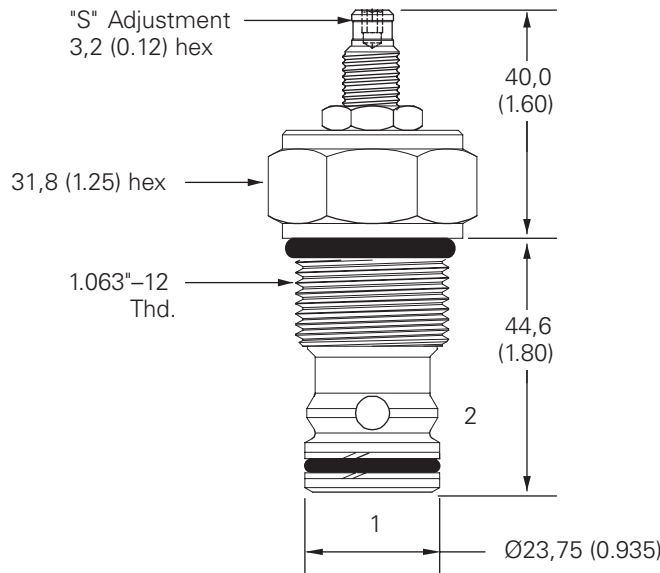

Aluminum housings can be used for pressures up to 210 bar (3000 psi)
Steel housings **must** be used for operating pressures **above** 210 bar (3000 psi)

FCV6-16

Flow control valve

Description

The FCV6-16 is a non-pressure compensated, adjustable, flow restrictor.

Functional Symbol

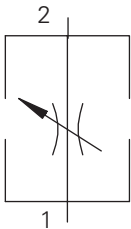

Sectional View

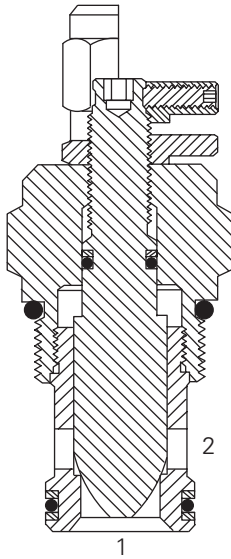

Operation

This valve allows flow between ports 1 and 2 through an increasing variable orifice when the adjustment is turned

counterclockwise. In the full clockwise position this valve provides tight shut-off.

RATINGS AND SPECIFICATIONS

Performance data is typical with fluid at 21,8 cSt (105 SUS) and 49°C (120°F)

Typical application pressure (all ports)	210 bar (3000 psi)
Cartridge fatigue pressure (infinite life)	210 bar (3000 psi)
Rated flow	208 L/min (55 USgpm)
Internal leakage	Port 2 to 1; <5 drops/min maximum @ 210 bar (3000 psi)
Temperature range	-40° to 120°C (-40° to 248°F)
Cavity	C-16-2
Fluids	All general purpose hydraulic fluids such as: MIL-H-5606, SAE 10, SAE 20, etc.
Filtration	Cleanliness code 18/16/13
Standard housing materials	Aluminum
Weight cartridge only	0,37 kg (0.81 lbs.)
Seal kits	889631 Buna-N 889635 Viton®

Viton is a registered trademark of E.I. DuPont

Pressure Drop Curve

Cartridge only

Full open port 1 to port 2 or port 2 to port 1

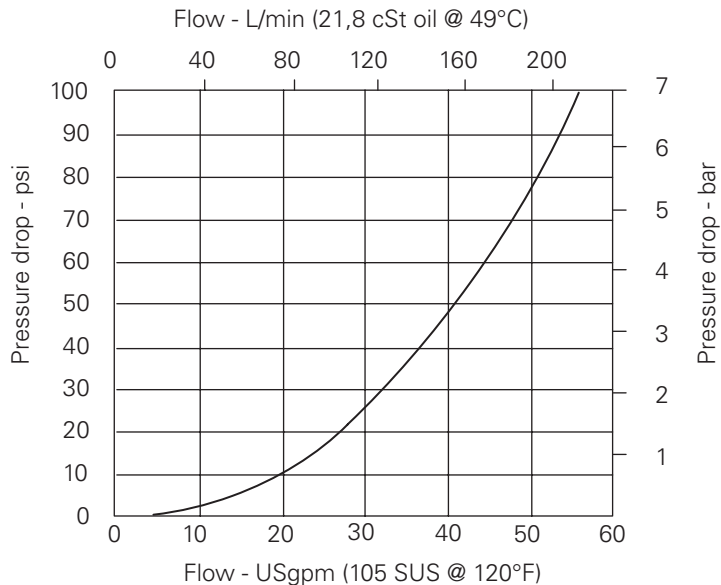

FCV6-16 (V) - * - * - NV - 00**

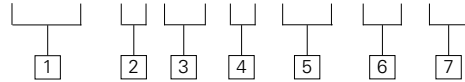

1 Function
FCV6 – Flow control valve

2 Size
16 – 16 Size

3 Seals
Blank– Buna-N
V – Viton®

4 Style
C – Cap
K – Knob
S – Screw

5 Port size
0 – Cartridge only

CODE	PORT SIZE	HOUSING NUMBER	
		Aluminum Light duty	Aluminum Fatigue rated
6B	3/4" BSPP	02-175463	–
12T	SAE 12	566149	–
4G	1/2" BSPP	–	876716
6G	3/4" BSPP	–	876718
10H	SAE 10	–	876717
12H	SAE 12	–	566113

See section J for housing details.

6 Controlled flow option
NV – Needle valve

7 Special features
00 – None
 (Only required if valve has special features, omitted if "00")



Dimensions

mm (inch)

Torque cartridge in aluminum housing to 108–122 Nm (80–90 ft.lbs)

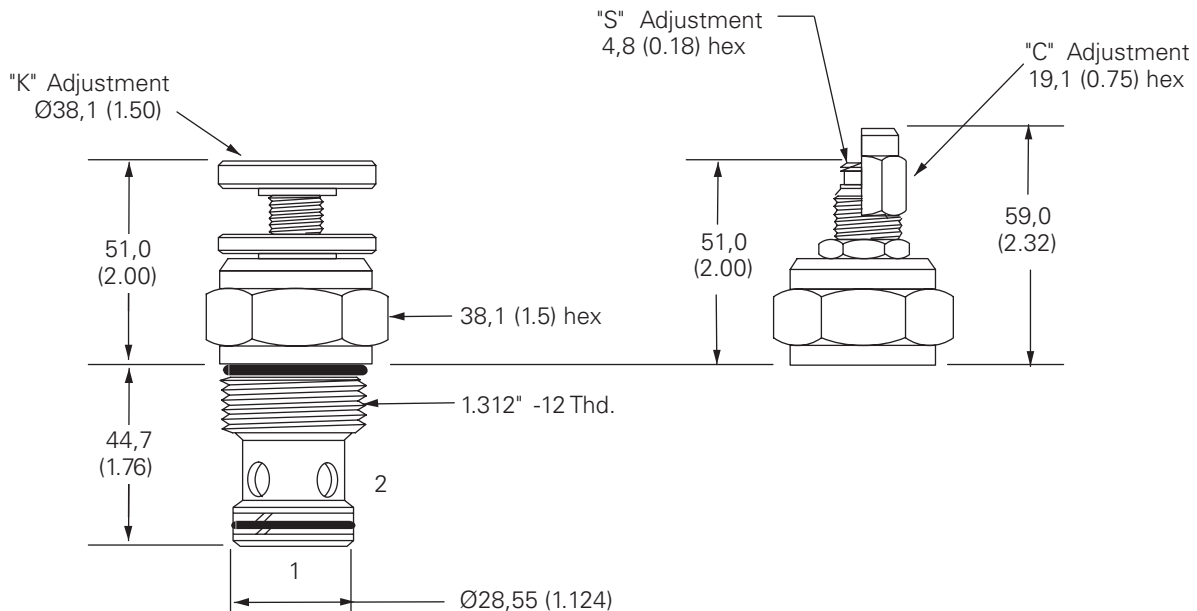

VF1-10/VF11-10

Velocity fuse

Description

The VF1*-10 is a screw-in cartridge velocity fuse.

Functional Symbol

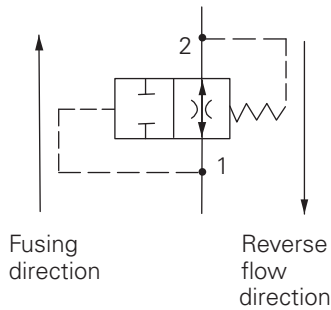

Profile View

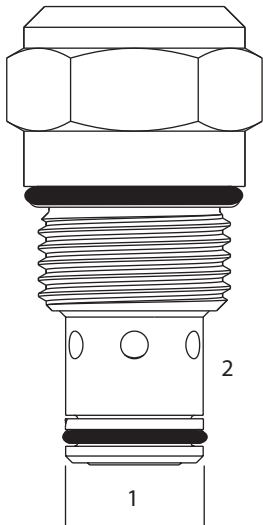

Application Note

The valve is not intended for use in pump unloading applications

Operation

This valve is normally open from port 1 to port 2. When flow exceeds the setting of the valve, it closes. The valve returns to the open condition when the pressure at port 1 is reduced to less than 80 psi.

RATINGS AND SPECIFICATIONS

Performance data is typical with fluid at 21,8 cSt (105 SUS) and 49°C (120°F)

Typical application pressure (all ports) VF1/VF11	210 bar (3000psi) 350 bar (5000 psi)
Cartridge fatigue pressure (infinite life) VF1/VF11	210 bar (3000psi) 350 bar (5000 psi)
Rated flow	23 L/min (6 USgpm)
Flow regulation accuracy	1,9–22,7 L/min (0,5–6,0 USgpm) ±20%
Factory set maximum flow rate accuracy under standard test conditions and within the above ranges	
Internal leakage	Port 2 to 1; <5 drops/min maximum @ 210 bar (3000 psi)
Temperature range	-40° to 120°C (-40° to 248°F)
Cavity	C-10-2
Fluids	All general purpose hydraulic fluids such as: MIL-H-5606, SAE 10, SAE 20, etc.
Filtration	Cleanliness code 18/16/13
Standard housing materials	Aluminum or Steel
Weight cartridge only	0,11 kg (0.25 lbs.)
Seal kits	565803 Buna-N 566086 Viton®
Viton is a registered trademark of E.I. DuPont	

Typical Flow Regulation

Cartridge only

A -22,8 L/min (6 USgpm) maximum flow setting

— Port 1 to 2, fusing direction

--- Port 2 to 1, reverse flow down to 0

B -14,44 L/min (3 USgpm) maximum flow setting

— Port 1 to 2, fusing direction

--- Port 2 to 1, reverse flow down to 0

C -3,8 L/min (1 USgpm) maximum flow setting

— Port 1 to 2, fusing direction

--- Port 2 to 1, reverse flow down to 0

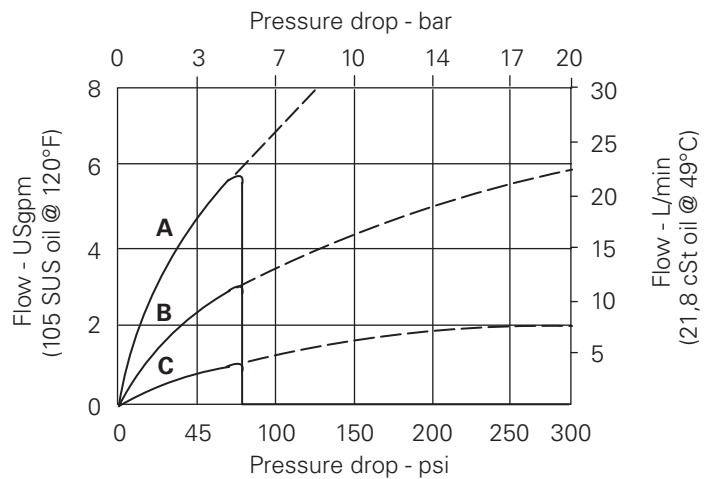

VF(*)1 – 10 (V) – F – ** – *.* – 00

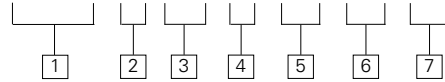

1 Function

VF1 – Velocity fuse 210 bar (3000 psi)

VF11 – Velocity fuse 350 bar (5000 psi)

2 Size

10 – 10 Size

3 Seals

N or Blank – Buna-N
V – Viton®

4 Adjustment

F – Fixed orifice

5 Port size

0 – Cartridge only

CODE	PORT SIZE	HOUSING NUMBER		
		Aluminum Light duty	Aluminum Fatigue rated	Steel
(A)3B	3/8" BSPP	02-175462	–	–
(A)6T	SAE 6	566151	–	–
(A)2G	1/4" BSPP	–	876702	–
(A)3G	3/8" BSPP	–	876703	–
(A)6H	SAE 6	–	876700	–
(A)8H	SAE 8	–	876701	–
S6T	SAE 6	–	–	02-175100
S8T	SAE 8	–	–	02-175101
S2G	1/4" BSPP	–	–	02-175102
S3G	3/8" BSPP	–	–	02-175103

See section J for housing details.

6 Factory set flow rate, nominal

(Specify in USgpm)
Range 1.9–22.7 L/min
(0.5)–6.0 USgpm)

7 Special features

00 – None
(Only required if valve has special features, omitted if "00")



Dimensions

mm (inch)

Torque cartridge in housing:
A – 47–54 Nm (35–40 ft.lbs)
S – 68–75 Nm (50–55 ft.lbs)



Aluminum housings can be used for pressures up to 210 bar (3000 psi)

Steel housings **must** be used for operating pressures **above** 210 bar (3000 psi)

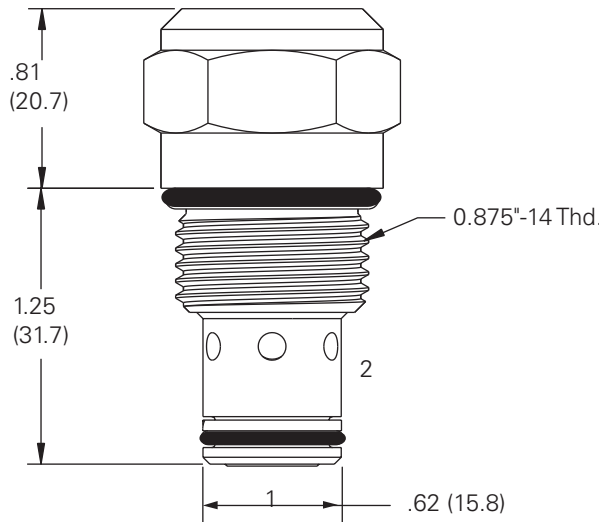

VF1-16

Velocity fuse

Description

The VF1-16-F is a factory-set, screw-in cartridge velocity fuse.

Operation

This valve is normally open from port 1 to port 2. When flow exceeds the setting of the valve, it closes. The valve returns to the open condition when the pressure at port 1 is reduced to less than 80 psi.

Functional Symbol

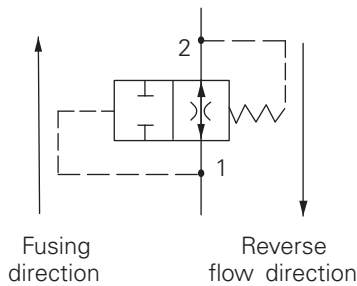

Sectional View

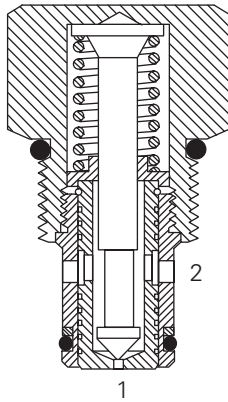

Application Note

The valve is not intended for use in pump unloading applications

RATINGS AND SPECIFICATIONS

Performance data is typical with fluid at 21,8 cSt (105 SUS) and 49°C (120°F)

Typical application pressure (all ports)	210 bar (3000 psi)
Cartridge fatigue pressure (infinite life)	210 bar (3000 psi)
Rated flow	114 L/min (30 USgpm)
Flow regulation accuracy	9,5–114 L/min (2.5–30.0 USgpm) ±20%
	Factory set maximum flow rate accuracy under standard test conditions and within the above ranges
Internal leakage	Port 1 to 2 closed; <5 drops/min maximum @ 210 bar (3000 psi)
Temperature range	-40° to 120°C (-40° to 248°F)
Cavity	C-16-2
Fluids	All general purpose hydraulic fluids such as: MIL-H-5606, SAE 10, SAE 20, etc.
Filtration	Cleanliness code 18/16/13
Standard housing materials	Aluminum
Weight cartridge only	0,33 kg (0.72 lbs.)
Seal kits	565810 Buna-N 889609 Viton®

Viton is a registered trademark of E.I. DuPont

Typical Flow Regulation

Cartridge only

A -114 L/min (30 USgpm) maximum flow setting

— Port 1 to 2, fusing direction

--- Port 2 to 1, reverse flow down to 0

B -60 L/min (15 USgpm) maximum flow setting

— Port 1 to 2, fusing direction

--- Port 2 to 1, reverse flow down to 0

C -19 L/min (5 USgpm) maximum flow setting

— Port 1 to 2, fusing direction

--- Port 2 to 1, reverse flow down to 0

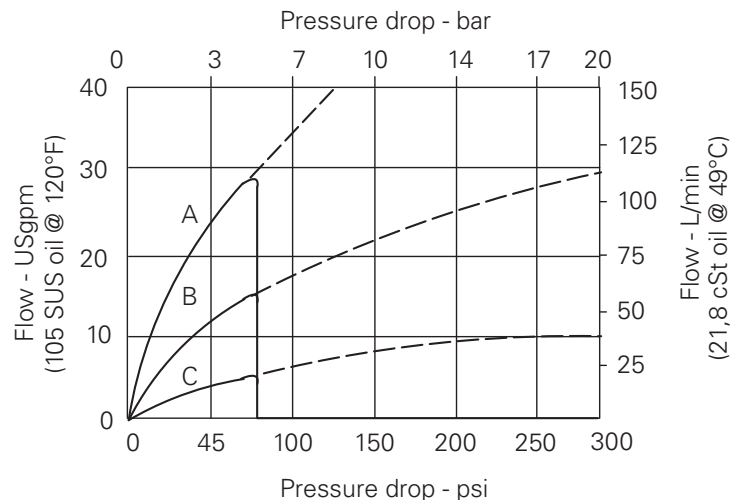

VF1 – 16 (V) – F – * – *.* – 00**

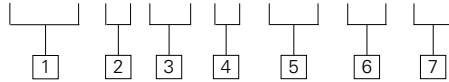

1 Function
VF1 – Velocity fuse

2 Size
16 – 16 Size

3 Seals
Blank – Buna-N
V – Viton®

4 Style
F – Factory set

5 Port size
0 – Cartridge only

CODE	PORT SIZE	HOUSING NUMBER	
		Aluminum Light duty	Aluminum Fatigue rated
6B	3/4" BSPP	02-175463	–
12T	SAE 12	566149	–
4G	1/2" BSPP	–	876716
6G	3/4" BSPP	–	876718
10H	SAE 10	–	876717
12H	SAE 12	–	566113

See section J for housing details.

6 Factory set flow rate, nominal
(Specify in USgpm)
Range 9,5-114 L/min
(2.5-30.0 USgpm)

7 Special features
00 – None
(Only required if valve has special features, omitted if "00")



Dimensions

mm (inch)

Torque cartridge in aluminum housing to 108–122 Nm (80–90 ft. lbs)

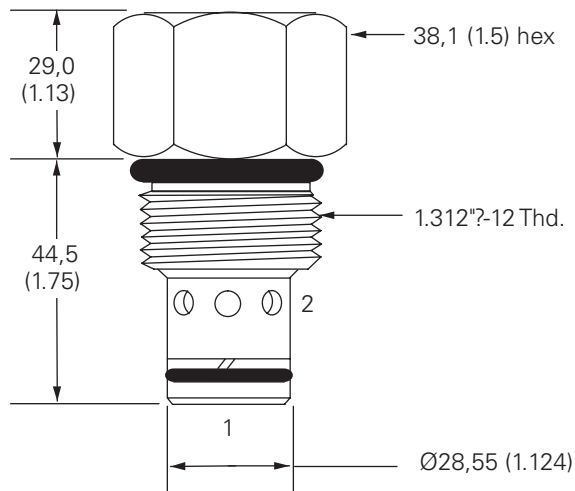

VF1-20

Velocity fuse

Description

The VF1-20-F is a factory-set, screw-in cartridge velocity fuse.

Operation

This valve is normally open from port 1 to port 2. When flow exceeds the setting of the valve, it closes. The valve returns to the open condition when the pressure at port 1 is reduced to less than 80 psi.

Functional Symbol

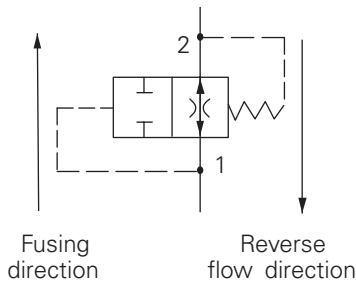

Sectional View

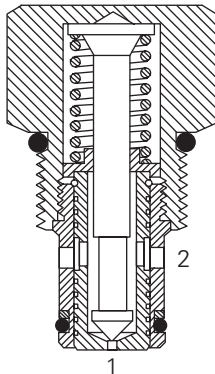

Application Note

The valve is not intended for use in pump unloading applications.

RATINGS AND SPECIFICATIONS

Performance data is typical with fluid at 21,8 cSt (105 SUS) and 49°C (120°F)

Typical application pressure (all ports)	210 bar (3000 psi)
Cartridge fatigue pressure (infinite life)	210 bar (3000 psi)
Rated flow	227 L/min (60 USgpm)
Flow regulation accuracy	60–227 L/min (15–60 USgpm) ±20%
Factory set maximum flow rate accuracy under standard test conditions and within the above ranges	
Internal leakage (Port 1 to 2 closed)	5 drops/min. maximum @ 210 bar (3000 psi)
Temperature range	-40° to 120° C (-40° to 248° F)
Cavity	C-20-2
Fluids	All general purpose hydraulic fluids such as: MIL-H-5606, SAE 10, SAE 20, etc.
Filtration	Cleanliness code 18/16/13
Standard housing materials	Aluminum
Weight cartridge only	0,82 kg. (1.80 lbs.)
Seal kits	889615 Buna-N 889619 Viton®

Viton is a registered trademark of E.I. DuPont

Typical Flow Regulation

Cartridge only

A -228 L/min (60 USgpm)
maximum flow setting

- Port 1 to 2, fusing direction
- Port 2 to 1, reverse flow down to 0

B -114 L/min (30 USgpm)
maximum flow setting

- Port 1 to 2, fusing direction
- Port 2 to 1, reverse flow down to 0

C -38 L/min (10 USgpm)
maximum flow setting

- Port 1 to 2, fusing direction
- Port 2 to 1, reverse flow down to 0

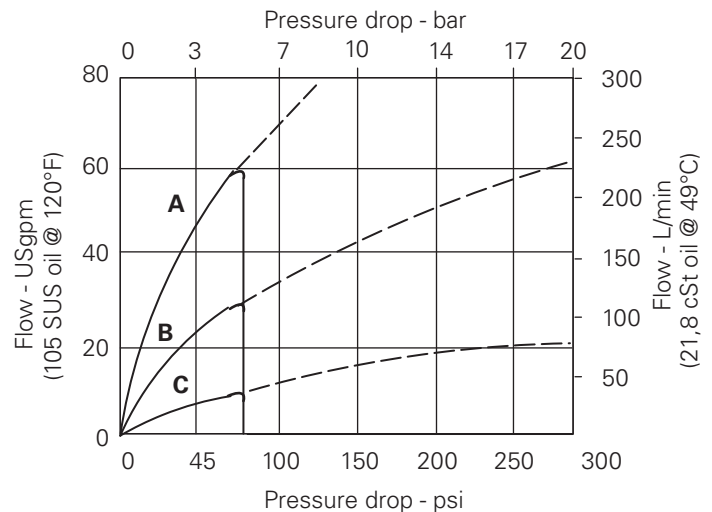

VF1-20 (V)-F-*-*.*-00**

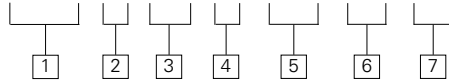

1 Function
VF1 – Velocity fuse

2 Size
20 – 20 Size

3 Seals
Blank – Buna-N
V – Viton®

4 Style
F – Factory set

5 Port size
0 – Cartridge only

CODE	PORT SIZE	HOUSING NUMBER	
		Aluminum Light duty	Aluminum Fatigue rated
8B	1" BSPP	02-175464	–
16T	SAE 16	566409	–
6G	3/4" BSPP	–	876732
8G	1" BSPP	–	876734
12H	SAE 12	–	876733
16H	SAE 16	–	876735

See section J for housing details.

6 Factory set flow rate, nominal
(Specify in USgpm)
Range 60-227 L/min
(15-60.0 USgpm)

7 Special features
00 – None
(Only required if valve has special features, omitted if "00")



Dimensions

mm (inch)

Torque cartridge in aluminum housing to 128–155 Nm (95–115 ft. lbs)

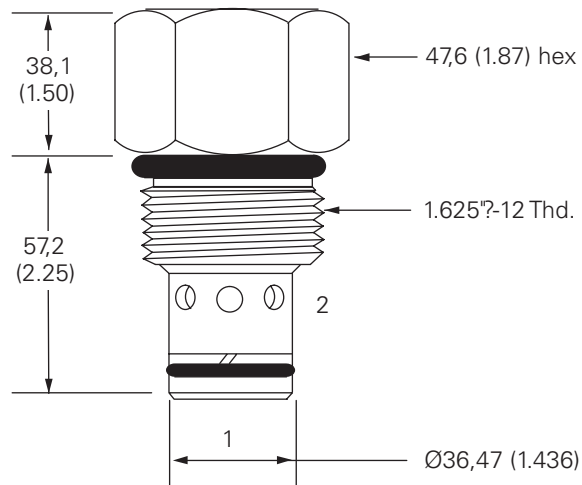

FDC1-10

Flow divider/combiner

Description

The FDC1-10 is a pressure compensated, spool type, screw-in, flow divider/combiner cartridge.

Operation

This valve is used in the dividing mode. It will take the inlet flow (port 3) and split the flow according to the ratio specified,

regardless of system pressure to ports 2 and 4. In the combining mode this valve will take the inlet

flows from ports 2 and 4 and combine them into port 3 according to the ratio specified.

Functional Symbol

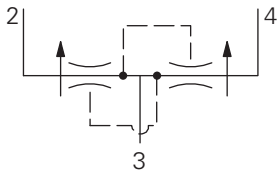

Sectional View

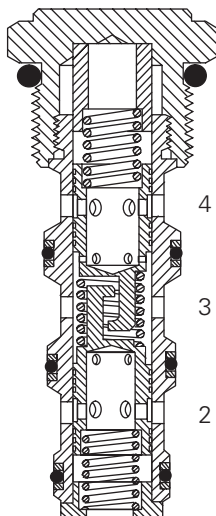

Note

Port 1 unused, blocked by blind cavity

RATINGS AND SPECIFICATIONS

Performance data is typical with fluid at 21,8 cSt (105 SUS) and 49°C (120°F)

Typical application pressure (all ports)	210 bar (3000 psi)
Cartridge fatigue pressure (infinite life)	210 bar (3000 psi)
Rated inlet flow	See model code
Temperature range	-40° to 120°C (-40° to 248°F)
Cavity	C-10-4
Fluids	All general purpose hydraulic fluids such as: MIL-H-5606, SAE 10, SAE 20, etc.
Filtration	Cleanliness code 18/16/13
Standard housing materials	Aluminum
Weight cartridge only	0,10 kg. (0.22 lbs.)
Seal Kits	889625 Buna-N 566080 Viton®

Viton is a registered trademark of E.I. DuPont

Typical Flow Regulation

Cartridge only

Flow Division

(See model code position 5)

- A - 3* spool
- B - 4* spool
- C - 6* spool
- D - 8* spool

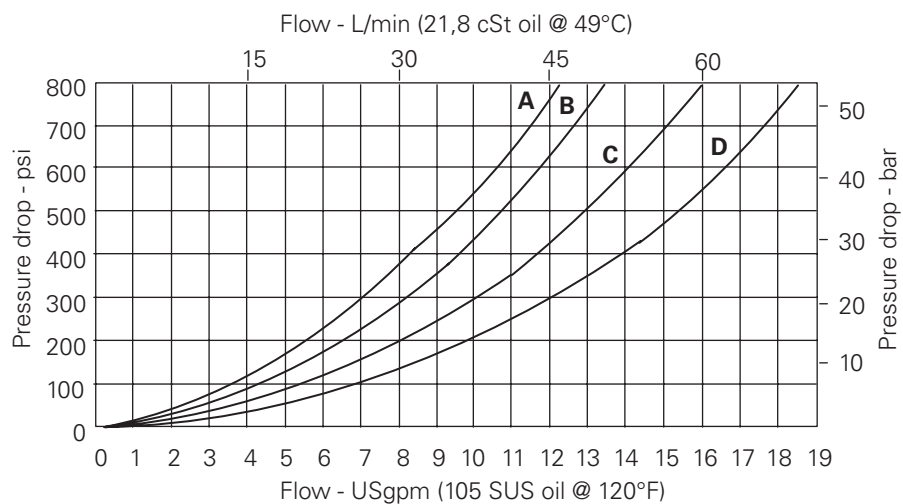

FDC1 – 10 (V) – ** – ** – 00

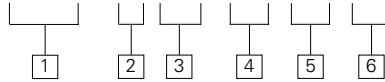

1 Function

FDC1 – Flow divider/
combiner

2 Size

10 – 10 Size

3 Seals

Blank– Buna-N
V – Viton®

4 Port size

0 – Cartridge only

5 Flow divisions (ratios)

CODE	FLOW DIVISION%		RATED INLET FLOW	
	Port 4	Port 2	L/min	(USgpm)
5.1	33	67	5,7	(1.5)
5.5	50	50	3,8	(1)
11	50	50	7,6	(2)
21	67	33	11,4	(3)
22	50	50	15,2	(4)
33	50	50	22,8	(6)
34	43	57	26,6	(7)
36	33	67	34,2	(9)
43	57	43	26,6	(7)
44	50	50	30,4	(8)
46	40	60	38,0	(10)
62	75	25	30,4	(8)
63	67	33	34,2	(9)
64	60	40	38,0	(10)
66	50	50	45,6	(12)
88	50	50	60,8	(16)

CODE	PORT SIZE	HOUSING NUMBER
Aluminum		
3B	3/8" BSPP	02-175467*
6T	SAE 6	566234*
2G	1/4" BSPP	02-185804
3G	3/8" BSPP	02-185805
6H	SAE 6	02-185802
8H	SAE 8	02-185803

*Light duty housing
See section J for housing details.

7 Special features

00 – None
(Only required if valve has
special features, omitted
if "00".)

SS - 316 Stainless Steel
external components

Dimensions

mm (inch)

Torque cartridge in
aluminum housing to
47–54 Nm (35–40 ft.lbs)

Notes

Port 1, unused, blocked by
blind cavity.

Minimum inlet flow should
not be less than 1/4 of
maximum inlet flow for
a given code.

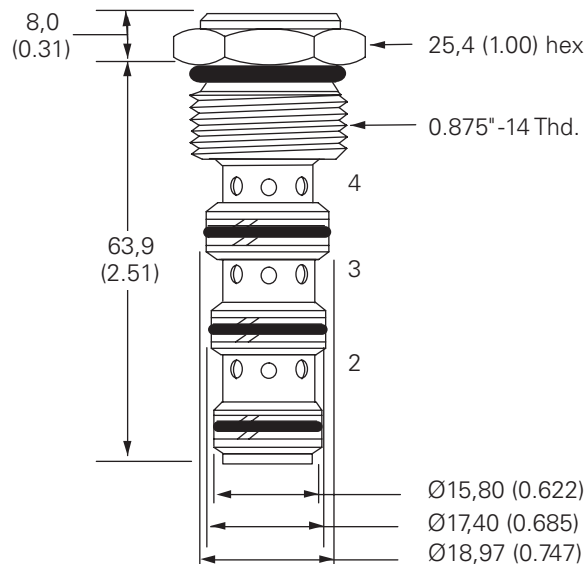

FDC11-10

High pressure flow divider/combiner

Description

The FDC11-10 is a pressure compensated, spool type, screw-in, flow divider/combiner cartridge.

Operation

This valve is used in the dividing mode. It will take the inlet flow (port 3) and split the flow according to the ratio specified,

regardless of system pressure to ports 2 and 4. In the combining mode this valve will take the inlet

flows from ports 2 and 4 and combine them into port 3 according to the ratio specified.

Functional Symbol

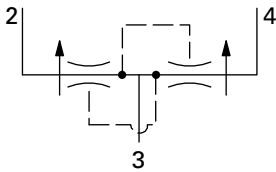

Sectional View

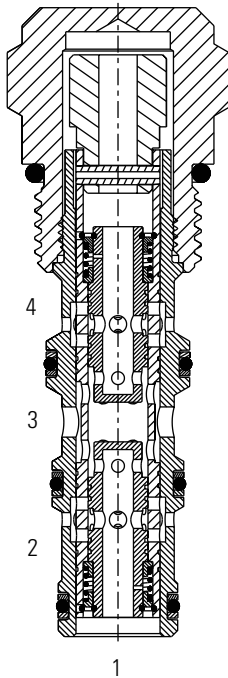

Note

Port 1 unused, blocked by blind cavity

RATINGS AND SPECIFICATIONS

Performance data is typical with fluid at 21,8 cSt (105 SUS) and 49°C (120°F)

Typical application pressure (all ports)	350 bar (5000 psi)
Cartridge fatigue pressure (infinite life)	350 bar (5000 psi)
Rated inlet flow	See model code
Temperature range	-40° to 120°C (-40° to 248°F)
Cavity	C-10-4
Fluids	All general purpose hydraulic fluids such as: MIL-H-5606, SAE 10, SAE 20, etc.
Filtration	Cleanliness code 18/16/13
Standard housing materials	Aluminum or steel
Weight cartridge only	0,16 kg. (0.35 lbs.)
Seal Kits	889625 Buna-N 566080 Viton®

Viton is a registered trademark of E.I. DuPont

Typical Flow Regulation

Cartridge only

Flow Division
(See model code position 5)

- A - 11 spool
- B - 22 spool
- C - 44 spool

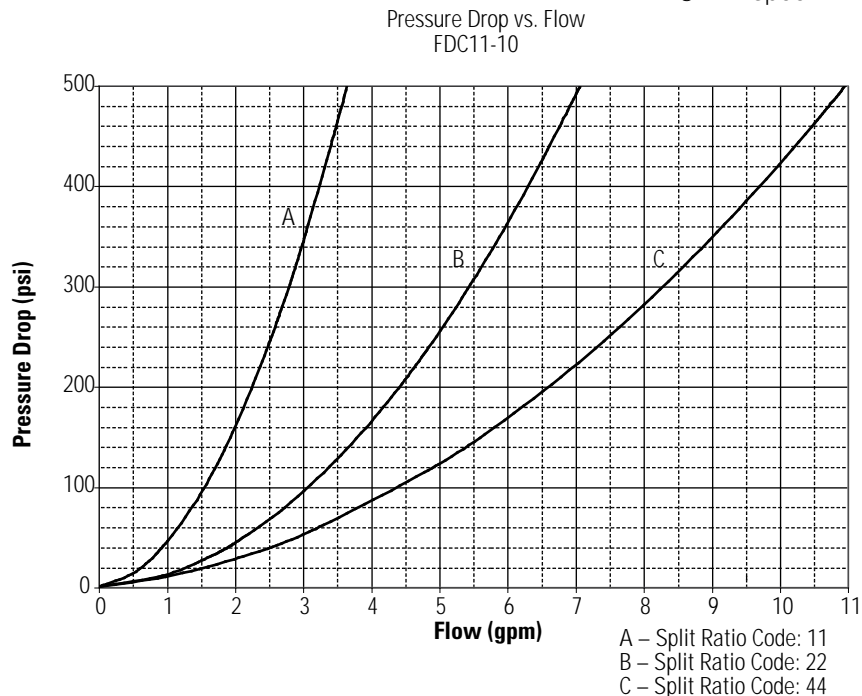

FDC11 – 10 (V) – * – ** – 00**

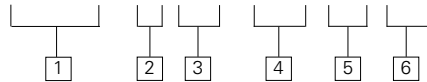

1 Function

FDC11 – High pressure flow divider/ combiner

2 Size

10 – 10 Size

3 Seals

Blank– Buna-N
V – Viton®

4 Port size

0 – Cartridge only

CODE	PORT SIZE	HOUSING
Aluminum		
A2G	1/4" BSPP	02-185804
A3G	3/8" BSPP	02-185805
A6H	SAE 6	02-185802
A8H	SAE 8	02-185803
Steel		
S2G	1/4" BSPP	02-175139
S3G	3/8" BSPP	02-175140
S6T	SAE 6	02-175137
S8T	SAE 8	02-175138

See section J for housing details.

Dimensions

mm (inch)

Torque cartridge in housing:

A – 47–54 Nm (35–40 ft.lbs)
S – 68–75 Nm (50–50 ft.lbs)

Notes

Port 1, unused, blocked by blind cavity.

Minimum inlet flow should not be less than 1/4 of maximum inlet flow for a given code.

5 Flow divisions (ratios)

CODE	FLOW DIVISION%		RATED INLET FLOW	
	Port 4	Port 2	L/min	(USgpm)
44	50	50	38	(10)
22	50	50	19	(5)
11	50	50	9,5	(2.5)
42	67	33	26,5	(7)
24	33	67	26,5	(7)
14	20	80	23,0	(6)
41	80	20	23,0	(6)

7 Special features

00 – None
(Only required if valve has special features, omitted if "00".)

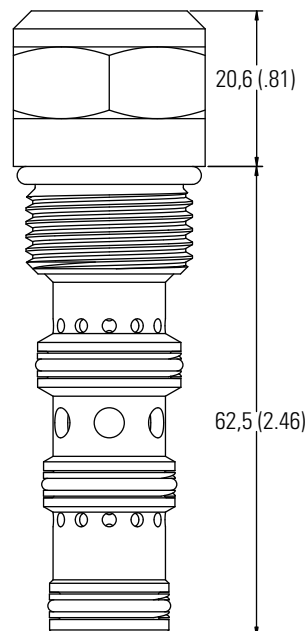

Aluminum housings can be used for pressures up to 210 bar (3000 psi)
Steel housings **must** be used for operating pressures **above** 210 bar (3000 psi)



FDC1-16

Flow divider/combiner

Description

The FDC1-16 is a pressure compensated, spool type, screw-in, flow divider/combiner cartridge.

Operation

This valve is used in the dividing mode. It will take the inlet flow (port 3) and split the flow according to the ratio specified,

regardless of system pressure to ports 2 and 4.

In the combining mode this valve will take the inlet

flows from ports 2 and 4 and combine them into port 3 according to the ratio specified.

Functional Symbol

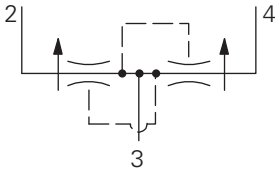

RATINGS AND SPECIFICATIONS

Performance data is typical with fluid at 21,8 cSt (105 SUS) and 49°C (120°F)

Typical application pressure (all ports)	210 bar (3000 psi)
Cartridge fatigue pressure (infinite life)	210 bar (3000 psi)
Rated inlet flow	See model code
Temperature range	-40° to 120° C (-40° to 248° F)
Cavity	C-16-4
Fluids	All general purpose hydraulic fluids such as: MIL-H-5606, SAE 10, SAE 20, etc.
Filtration	Cleanliness code 18/16/13
Standard housing materials	Aluminum
Weight cartridge only	0,35 kg (0.78 lbs.)
Seal Kits	889634 Buna-N 889638 Viton®

Viton is a registered trademark of E.I. DuPont

Sectional View

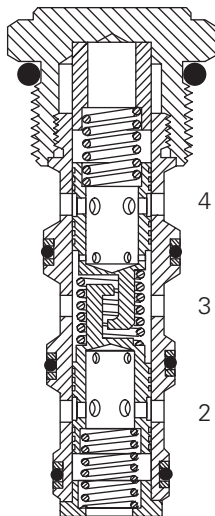

Note

Port 1 unused, blocked by blind cavity

Typical Flow Regulation

Cartridge only

Flow Division

(See model code position 5)

- A - 2* spool
- B - 3* spool
- C - 4* spool
- D - 5* spool
- E - 6* spool
- F - 8* spool

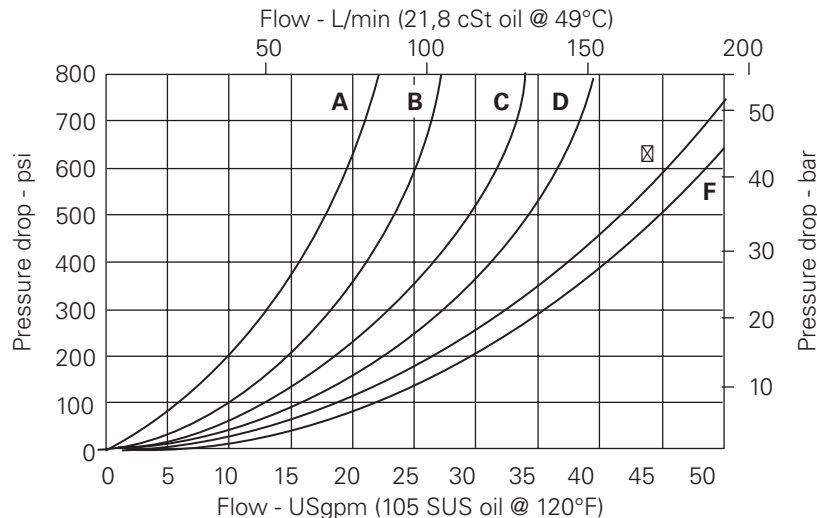

FDC1 – 16 (V) – * – ** – 00**

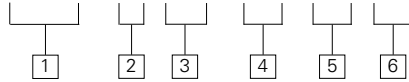

1 Function
FDC1 – Flow divider/
combiner

2 Size
16 – 16 Size

3 Seals
Blank– Buna-N
V – Viton®

4 Port size
0 – Cartridge only

CODE	PORT SIZE	HOUSING NUMBER
		Aluminum Light duty
12T	SAE 12	566200
6B	3/4" BSPP	02-175468

See section J for housing details.

5 Flow divisions (ratios)

CODE	FLOW DIVISION%		RATED INLET FLOW	
	Port 4	Port 2	L/min	(USgpm)
22	50	50	45,6	(12)
28	20	80	114,0	(30)
33	50	50	68,0	(18)
36	33	67	98,0	(26)
43	57	43	79,0	(21)
44	50	50	90,0	(24)
46	40	60	114,0	(30)
55	50	50	114,0	(30)
62	75	25	90,0	(24)
63	67	33	98,0	(26)
64	60	40	114,0	(30)
66	50	50	132,0	(35)
82	80	20	114,0	(30)
84	67	33	132,0	(35)
88	50	50	178,0	(47)

6 Special features

00 – None
(Only required if valve has
special features, omitted
if "00".)

Dimensions

mm (inch)

Torque cartridge in
aluminum housing to
108–122 Nm (80–90 ft. lbs)

Notes

Port 1, unused, blocked by
blind cavity.

Minimum inlet flow should
not be less than 1/4 of
maximum inlet flow for
a given code.

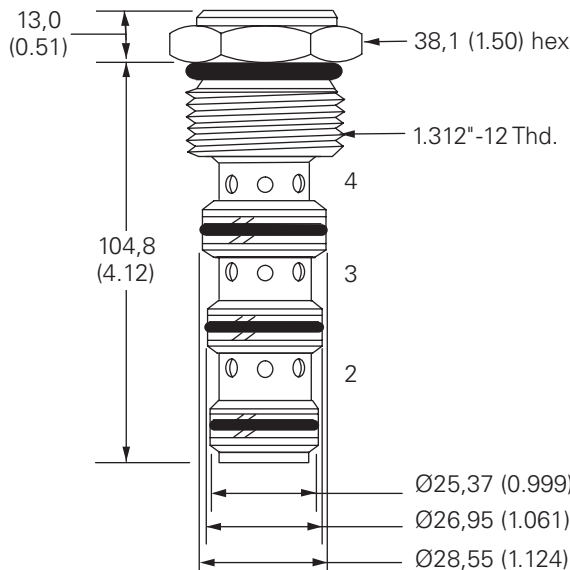

FDC11-16

Flow divider/combiner

Description

The FDC11-16 is a pressure compensated, spool type, screw-in, flow divider/combiner cartridge.

Operation

This valve is used in the dividing mode. It will take the inlet flow (port 3) and split the flow according to the ratio specified,

regardless of system pressure to ports 2 and 4.
In the combining mode this valve will take the inlet

flows from ports 2 and 4 and combine them into port 3 according to the ratio specified.

Functional Symbol

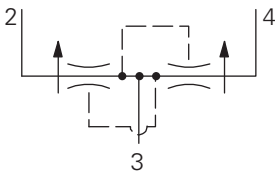

RATINGS AND SPECIFICATIONS

Performance data is typical with fluid at 21,8 cSt (105 SUS) and 49°C (120°F)

Typical application pressure (all ports)	350 bar (5000 psi)
Cartridge fatigue pressure (infinite life)	350 bar (5000 psi)
Rated inlet flow	See model code
Temperature range	-40° to 120° C (-40° to 248° F)
Cavity	C-16-4
Fluids	All general purpose hydraulic fluids such as: MIL-H-5606, SAE 10, SAE 20, etc.
Filtration	Cleanliness code 18/16/13
Standard housing materials	Aluminum or steel
Weight cartridge only	0,35 kg (0.78 lbs.)
Seal Kits	889634 Buna-N 889638 Viton®

Viton is a registered trademark of E.I. DuPont

Sectional View

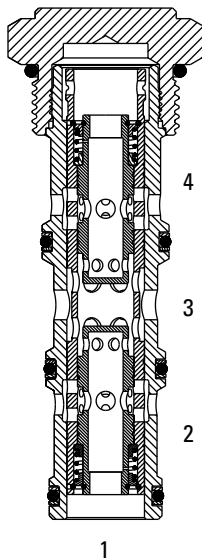

Note

Port 1 unused, blocked by blind cavity

Typical Flow Regulation

Cartridge only

Flow Division

- A - 66
- B - 44
- C - 33
- D - 22

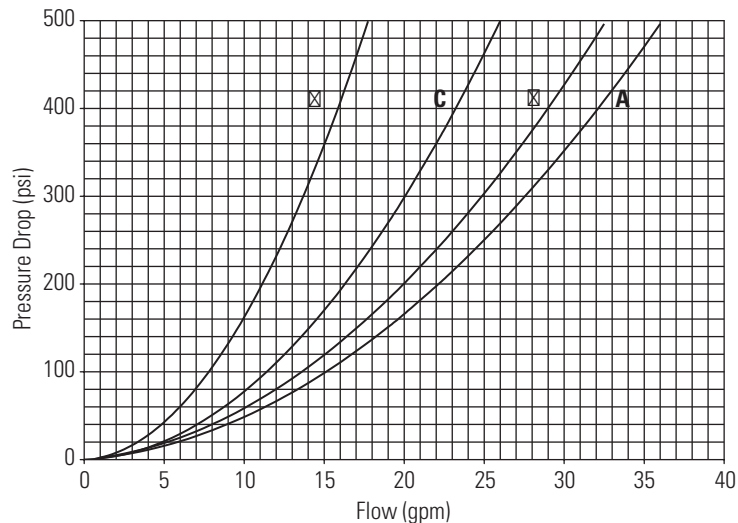

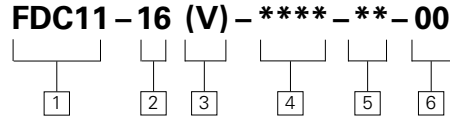

1 Function

FDC11 – Flow divider/
combiner

2 Size

16 – 16 Size

3 Seals

Blank – Buna-N
V – Viton®

4 Port size

0 – Cartridge only

5 Flow divisions (ratios)

CODE	FLOW DIVISION%		RATED INLET FLOW	
	Port 4	Port 2	L/min	(USgpm)
66	50	50	133,0	(35)
44	50	50	114,0	(30)
33	50	50	83,6	(22)
22	50	50	57,0	(15)
64	60	40	140,6	(37)
45	40	60	140,6	(37)
62	75	25	114,0	(30)
26	25	75	114,0	(30)
42	67	33	83,6	(22)
24	33	67	83,6	(22)

CODE	PORT SIZE	HOUSING NUMBER
Aluminum		
A12T	SAE 12	20785*
A6B	3/4" BSPP	02-186592*
A4G	1/2" BSPP	30706
A6G	3/4" BSPP	30708
A10H	SAE 10	30707
A12H	SAE 12	30709
Steel		
S4G	1/2" BSPP	02-175143
S6G	3/4" BSPP	02-175144
S10T	SAE 10	02-175141
S12T	SAE 12	02-175142

*Light duty housing. See section J for housing details.

Dimensions

mm (inch)

Torque cartridge in
aluminum housing to
108–122 Nm (80–90 ft. lbs)

Notes

Port 1, unused, blocked by
blind cavity.

Minimum inlet flow should
not be less than 1/4 of
maximum inlet flow for
a given code.

6 Special features

00 – None
(Only required if valve has
special features, omitted
if "00".)

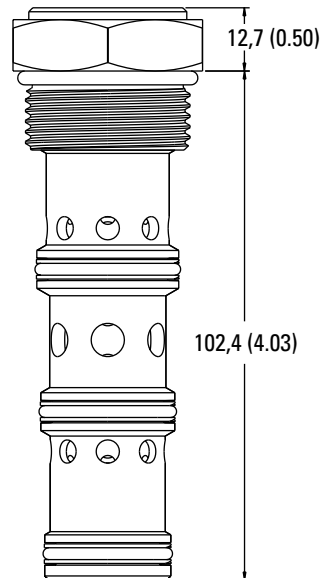

FDC1-20

Flow divider/combiner

Description

The FDC1-20 is a line mounted pressure compensated, spool type, flow divider/combiner valve.

Operation

This valve is used in the dividing mode. It will take the inlet flow (port 1) and split the flow according to the ratio specified,

regardless of system pressure to ports 2 and 4.

In the combining mode this valve will take the inlet

flows from ports 2 and 3 and combine them into port 1 according to the ratio specified.

Functional Symbol

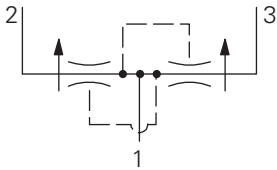

Sectional View

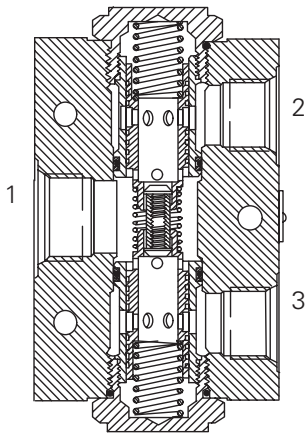

RATINGS AND SPECIFICATIONS

Performance data is typical with fluid at 21,8 cSt (105 SUS) and 49°C (120°F)

Typical application pressure (all ports)	210 bar (3000 psi)
Cartridge fatigue pressure (infinite life)	210 bar (3000 psi)
Rated inlet flow	See model code
Fluids	All general purpose hydraulic fluids such as: MIL-H-5606, SAE 10, SAE 20, etc.
Filtration	Cleanliness code 18/16/13
Standard housing materials	Aluminum
Weight cartridge only	2,6 kg. (5.75 lbs.)
Seal Kits	889639 Buna-N 889643 Viton®

Viton is a registered trademark of E.I. DuPont

Pressure Drop Curves

Flow Division:

(See model code position 5)

A - 3* spool

B - 4* spool

C - 6* spool

D - 8* spool

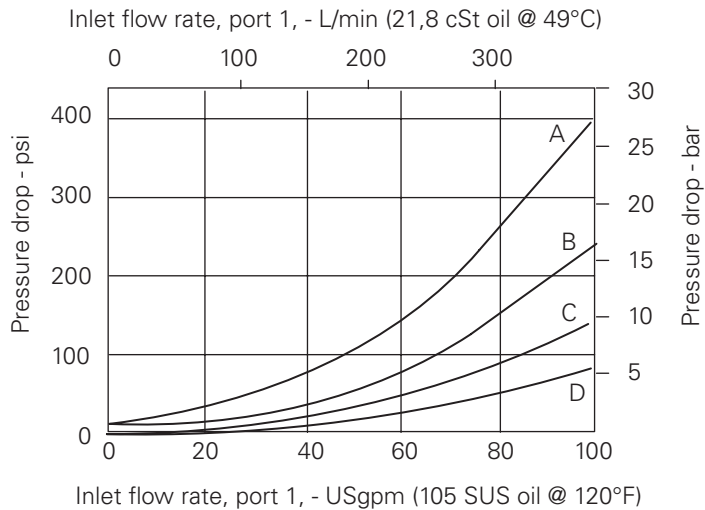

FDC1-20 (V) - * - ** - 00**

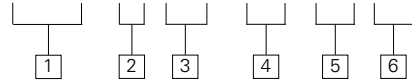

1 Function

FDC1 – Flow divider/
combiner

2 Size

20 – 20 Size

3 Seals

Blank– Buna-N
V – Viton®

4 Port size

16T – SAE 16 (light duty)
20T – SAE 20 (light duty)
(Available as a complete
assembly only.)

5 Flow divisions (ratios)

CODE	FLOW DIVISION%		MAX. INLET FLOW	
	Port 4	Port 2	L/min	(USgpm)
33	50	50	190,0	(50)
34	43	57	228,0	(60)
36	33	67	266,0	(70)
44	50	50	266,0	(70)
46	40	60	304,0	(80)
66	50	50	380,0	(100)
88	50	50	380,0	(100)

6 Special features

00 – None
(Only required if valve has
special features, omitted
if "00".)

Dimensions

mm (inch)

Torque cartridge in housing
128–155 Nm (95–115 ft. lbs)

Note

Minimum inlet flow should
not be less than 1/4 of
maximum inlet flow for a
given code.

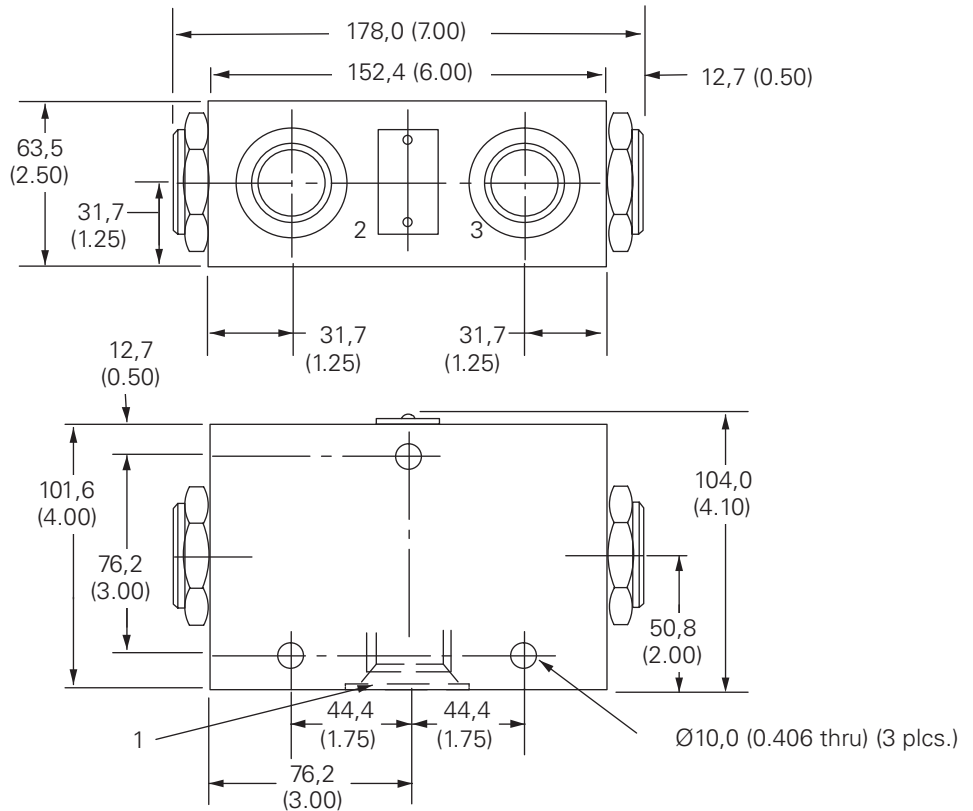

FDC3-10

Posi-traction valve

Description

The FDC3-10 is a pressure compensated, spool type, screw-in, posi-traction cartridge valve.

Operation

This valve is used in the dividing mode. It will take the inlet flow (port 3) and split the flow to ports 2 and 4.

In the combining mode this valve will take the inlet flows from ports 2 and 4 and combine them into

port 3 according to the ratio specified.

Functional Symbol

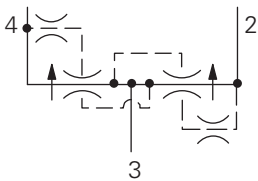

RATINGS AND SPECIFICATIONS

Performance data is typical with fluid at 21,8 cSt (105 SUS) and 49°C (120°F)

Typical application pressure (all ports)	210 bar (3000 psi)
Cartridge fatigue pressure (infinite life)	210 bar (3000 psi)
Rated inlet flow	See model code
Temperature range	-40° to 120° C (-40° to 248° F)
Cavity	C-10-4
Fluids	All general purpose hydraulic fluids such as: MIL-H-5606, SAE 10, SAE 20, etc.
Filtration	Cleanliness code 18/16/13
Standard housing materials	Aluminum
Weight cartridge only	0,10 kg (0.22 lbs.)
Seal kits	889625 Buna-N 566080 Viton®

Viton is a registered trademark of E.I. DuPont

Sectional View

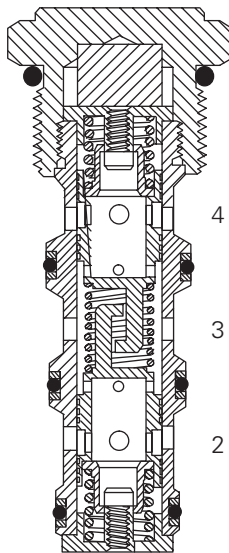

Pressure Drop Curves

Cartridge only

Flow Division

(See model code position 5)

- A - 33 spool
- B - 44 spool
- C - 66 spool
- D - 88 spool

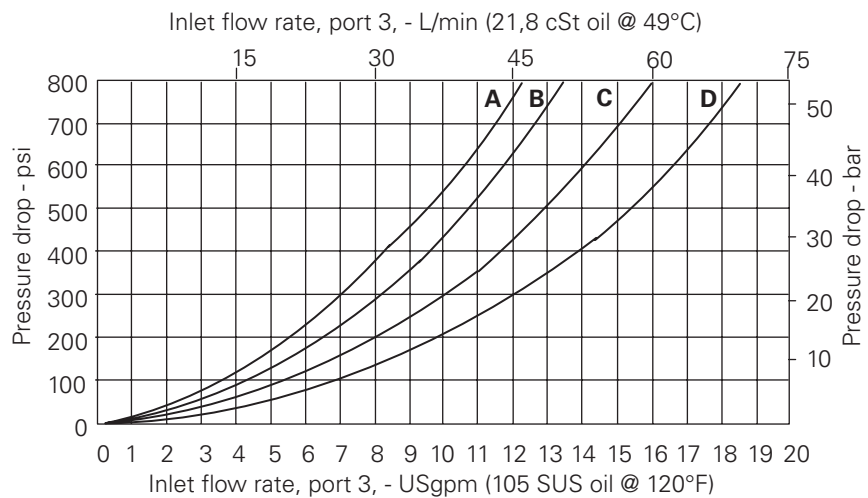

Note

Port 1 unused, blocked by blind cavity

FDC3 – 10 (V) – ** – ** – 00

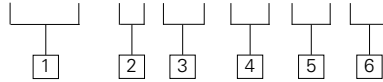

1 Function

FDC3 – Posi-traction valve

2 Size

10 – 10 Size

3 Seals

Blank– Buna-N
V – Viton®

4 Port size

0 – Cartridge only

5 Flow divisions (ratios)

CODE	FLOW DIVISION%		MAX. INLET FLOW	
	Port 4	Port 2	L/min	(USgpm)
33	50	50	22,8	(6.0)
44	50	50	30,4	(8.0)
66	50	50	45,6	(12.0)

CODE PORT SIZE HOUSING NUMBER

Aluminum		
3B	3/8" BSPP	02-175467*
6T	SAE 6	566234*
2G	1/4" BSPP	02-185804
3G	3/8" BSPP	02-185805
6H	SAE 6	02-185802
8H	SAE 8	02-185803

*Light duty housing

See section J for housing details.

6 Special features

00 – None
(Only required if valve has special features, omitted if "00")

Dimensions

mm (inch)

Torque cartridge in aluminum housing to 47–54 Nm (35–40 ft. lbs)

Notes

Port 1, unused, blocked by blind cavity.

Minimum inlet flow should not be less than 1/4 of maximum inlet flow for a given code.

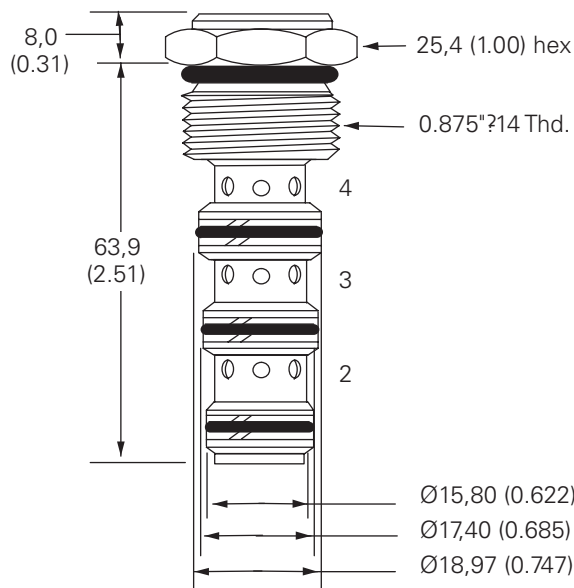

FDC13-10

High pressure posi-traction valve

Description

The FDC13-10 is a pressure compensated, spool type, screw-in, posi-traction cartridge valve.

Operation

This valve is used in the dividing mode. It will take the inlet flow (port 3) and split the flow to ports 2 and 4.

In the combining mode this valve will take the inlet flows from ports 2 and 4 and combine them into

port 3 according to the ratio specified.

Functional Symbol

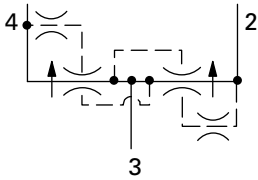

Sectional View

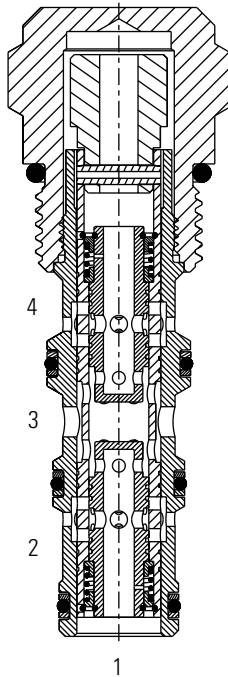

Note

Port 1 unused, blocked by blind cavity

RATINGS AND SPECIFICATIONS

Performance data is typical with fluid at 21,8 cSt (105 SUS) and 49°C (120°F)

Typical application pressure (all ports)	350 bar (5000 psi)
Cartridge fatigue pressure (infinite life)	350 bar (5000 psi)
Rated inlet flow	See model code
Temperature range	-40° to 120° C (-40° to 248° F)
Cavity	C-10-4
Fluids	All general purpose hydraulic fluids such as: MIL-H-5606, SAE 10, SAE 20, etc.
Filtration	Cleanliness code 18/16/13
Standard housing materials	Aluminum or steel
Weight cartridge only	0,16 kg (0.35 lbs.)
Seal kits	889625 Buna-N 566080 Viton®

Viton is a registered trademark of E.I. DuPont

Pressure Drop Curves

Cartridge only

Flow Division

(See model code position 5)

A - 44 spool

B - 22 spool

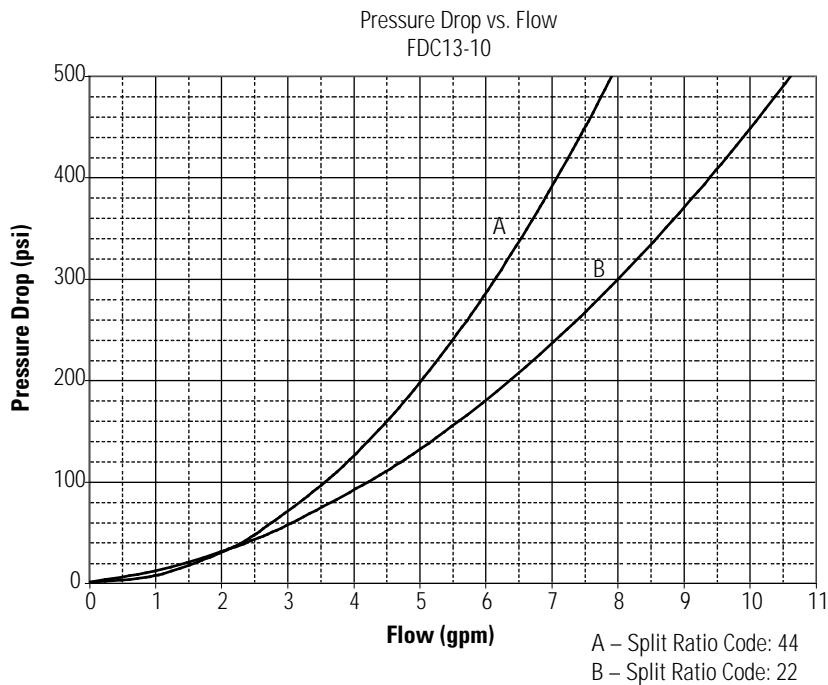

FDC13 – 10 (V) – * – ** – 00**

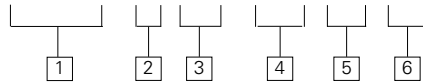

1 Function

FDC13 – Posi-traction valve

2 Size

10 – 10 Size

3 Seals

Blank– Buna-N
V – Viton®

4 Port size

0 – Cartridge only

5 Flow divisions (ratios)

CODE	FLOW DIVISION%		MAX. INLET FLOW	
	Port 4	Port 2	L/min	(USgpm)
22	50	50	19	(5.0)
44	50	50	38	(10.0)

CODE PORT SIZE HOUSING NUMBER

Aluminum		
A2G	1/4" BSPP	02-185804
A3G	3/8" BSPP	02-185805
A6H	SAE 6	02-185802
A8H	SAE 8	02-185803
Steel		
S2G	1/4" BSPP	02-175139
S3G	3/8" BSPP	02-175140
S6T	SAE 6	02-175137
S8T	SAE 8	02-175138

See section J for housing details.

6 Special features

00 – None
(Only required if valve has special features, omitted if "00".)

Dimensions

mm (inch)

Torque cartridge in housing:
A – 47–54 Nm (35–40 ft. lbs)
S – 68–75 Nm (50–50 ft. lbs)

Notes

Port 1, unused, blocked by blind cavity.

Minimum inlet flow should not be less than 1/4 of maximum inlet flow for a given code.

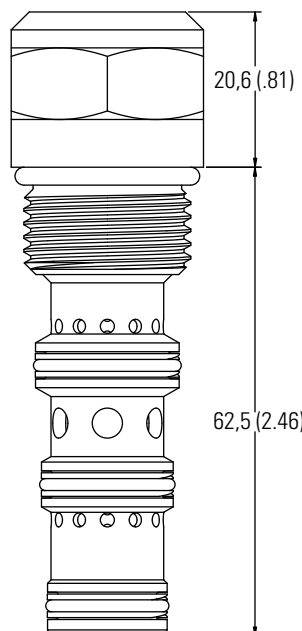

Aluminum housings can be used for pressures up to 210 bar (3000 psi)
Steel housings **must** be used for operating pressures **above** 210 bar (3000 psi)

FDC3-16

Posi-traction valve

Description

The FDC3-16 is a pressure compensated, spool type, screw-in, posi-traction cartridge valve.

Operation

This valve is used in the dividing mode. It will take the inlet flow (port 3) and split the flow to ports 2 and 4.

In the combining mode this valve will take the inlet flows from ports 2 and 4 and combine them into port 3 according to the ratio specified.

Functional Symbol

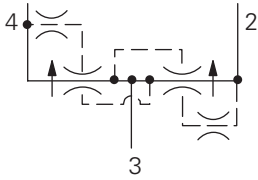

Sectional View

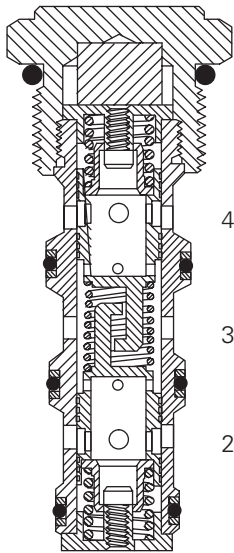

Note

Port 1 unused, blocked by blind cavity

RATINGS AND SPECIFICATIONS

Performance data is typical with fluid at 21,8 cSt (105 SUS) and 49°C (120°F)

Typical application pressure (all ports)	210 bar (3000 psi)
Cartridge fatigue pressure (infinite life)	210 bar (3000 psi)
Rated inlet flow	See model code, item
Temperature range	-40° to 120° C (-40° to 248° F)
Cavity	C-16-4 (See page 70)
Fluids	All general purpose hydraulic fluids such as: MIL-H-5606, SAE 10, SAE 20, etc.
Filtration	Cleanliness code 18/16/13
Standard housing materials	Aluminum
Weight cartridge only	0,35 kg. (0.78 lbs.)
Seal kits	889634 Buna-N 889638 Viton®

Viton is a registered trademark of E.I. DuPont

Pressure Drop Curves

Cartridge only

Flow Division

(See model code position 5)

- A - 22 spool
- B - 33 spool
- C - 44 spool
- D - 55 spool
- E - 66 spool
- F - 88 spool

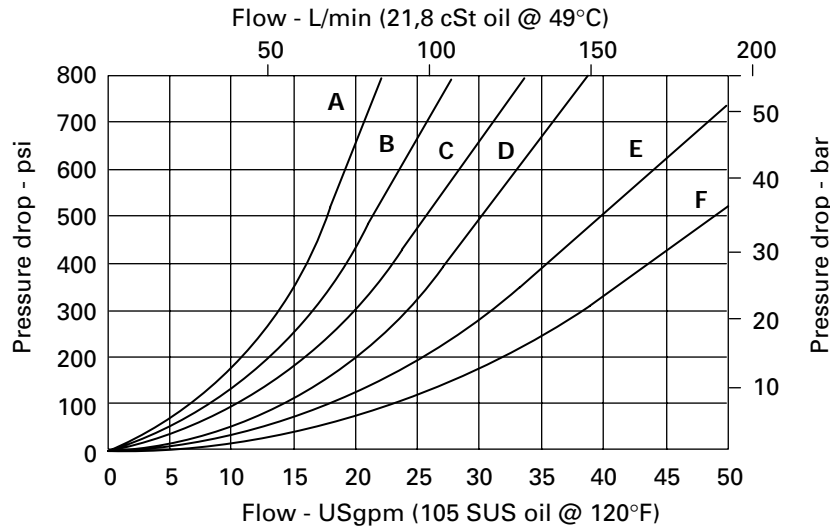

FDC3 – 16 (V) – ** – ** – 00

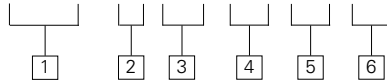

1 Function

FDC3 – Posi-traction valve

2 Size

16 – 16 Size

3 Seals

Blank – Buna-N
V – Viton®

4 Port size

0 – Cartridge only

5 Flow divisions (ratios)

CODE	FLOW DIVISION %		MAX. INLET FLOW	
	Port 4	Port 2	L/min	(USgpm)
22	50	50	57,0	(15)
33	50	50	76,0	(20)
44	50	50	106,4	(28)
55	50	50	126,2	(34)
66	50	50	152,0	(40)
88	50	50	228,0	(60)

6 Special features

00 – None
(Only required if valve has special features, omitted if "00")

CODE	PORT SIZE	HOUSING NUMBER
Aluminum Light duty		
12T	SAE 12	566200
6B	3/4" BSPP	02-175468

See section J for housing details.

Dimensions

mm (inch)

Torque cartridge in aluminum housing
108–122 Nm (80–90 ft. lbs)

Notes

Port 1, unused, blocked by blind cavity.

Minimum inlet flow should not be less than 1/4 of maximum inlet flow for a given code.

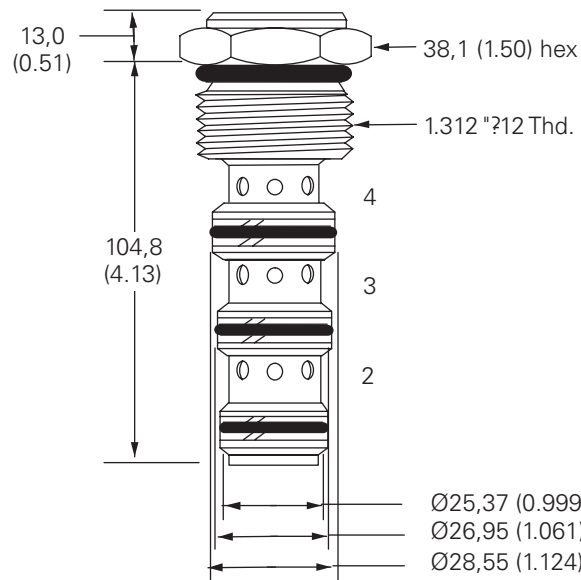

FDC13-16

Posi-traction valve

Description

The FDC13-16 is a pressure compensated, spool type, screw-in, posi-traction cartridge valve.

Operation

This valve is used in the dividing mode. It will take the inlet flow (port 3) and split the flow to ports 2 and 4.

In the combining mode this valve will take the inlet flows from ports 2 and 4 and combine them into port 3 according to the ratio specified.

Functional Symbol

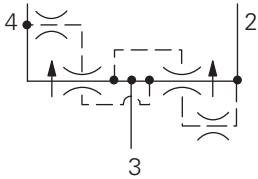

Sectional View

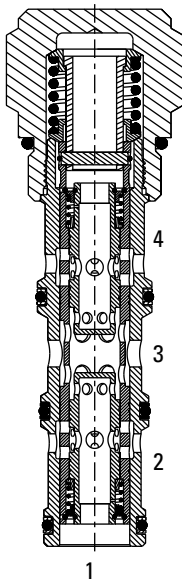

Note

Port 1 unused, blocked by blind cavity

RATINGS AND SPECIFICATIONS

Performance data is typical with fluid at 21,8 cSt (105 SUS) and 49°C (120°F)

Typical application pressure (all ports)	350 bar (5000 psi)
Cartridge fatigue pressure (infinite life)	350 bar (5000 psi)
Rated inlet flow	See model code, item
Temperature range	-40° to 120° C (-40° to 248° F)
Cavity	C-16-4 (See page 70)
Fluids	All general purpose hydraulic fluids such as: MIL-H-5606, SAE 10, SAE 20, etc.
Filtration	Cleanliness code 18/16/13
Standard housing materials	Aluminum or steel
Weight cartridge only	0,35 kg. (0.78 lbs.)
Seal kits	889634 Buna-N 889638 Viton®

Viton is a registered trademark of E.I. DuPont

Pressure Drop Curves

Cartridge only

Flow Division

- A - 66
- B - 44
- C - 33
- D - 22

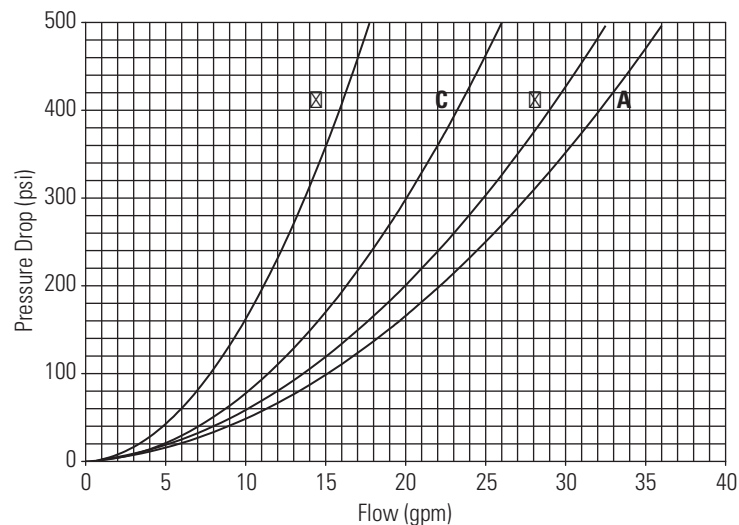

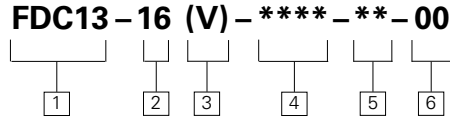

- 1** Function
FDC13 – Posi-traction valve

- 2** Size
16 – 16 Size

- 3** Seals
Blank – Buna-N
V – Viton®

5 Flow divisions (ratios)

CODE	FLOW DIVISION %		MAX. INLET FLOW	
	Port 4	Port 2	L/min	(USgpm)
66	50	50	133,0	(35)
44	50	50	114,0	(30)
33	50	50	83,6	(22)
22	50	50	57,0	(15)

- 6** Special features
00 – None
(Only required if valve has special features, omitted if "00")

4 Port size
0 – Cartridge only

CODE	PORT SIZE	HOUSING NUMBER
Aluminum		
A4G	1/2" BSPP	30706
A6G	3/4" BSPP	30708
A10H	SAE 10	30707
A12H	SAE 12	30709
Steel		
S4G	1/2" BSPP	02-175143
S6G	3/4" BSPP	02-175144
S10T	SAE 10	02-175141
S12T	SAE 12	02-175142

See section J for housing details.

Dimensions
mm (inch)
Torque cartridge in aluminum housing
108–122 Nm (80–90 ft. lbs)

Notes
Port 1, unused, blocked by blind cavity.

Minimum inlet flow should not be less than 1/4 of maximum inlet flow for a given code.

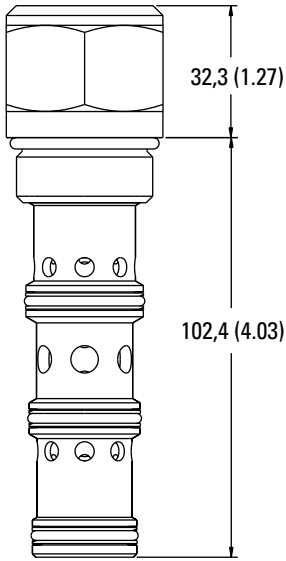

FDC3-20

Posi-traction valve

Description

The FDC3-20 is a line mounted, pressure compensated, spool type, posi-traction cartridge valve.

Operation

This valve is used in the dividing mode. It will take the inlet flow (port 1) and split the flow to ports 2 and 3.

In the combining mode this valve will take the inlet flows from ports 2 and 3 and combine them into

port 1 according to the ratio specified.

Functional Symbol

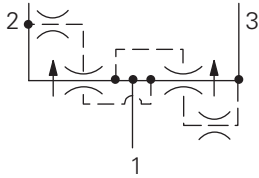

RATINGS AND SPECIFICATIONS

Performance data is typical with fluid at 21,8 cSt (105 SUS) and 49°C (120°F)

Typical application pressure (all ports)	210 bar (3000 psi)
Cartridge fatigue pressure (infinite life)	210 bar (3000 psi)
Rated inlet flow	See model code
Temperature range	-40° to 120°C (-40° to 248°F)
Fluids	All general purpose hydraulic fluids such as: MIL-H-5606, SAE 10, SAE 20, etc.
Filtration	Cleanliness code 18/16/13
Standard housing materials	Aluminum
Weight cartridge only	2,6 kg. (5.75 lbs.)
Seal kits (2 req'd.)	889639 Buna-N 889643 Viton®

Viton is a registered trademark of E.I. DuPont

Sectional View

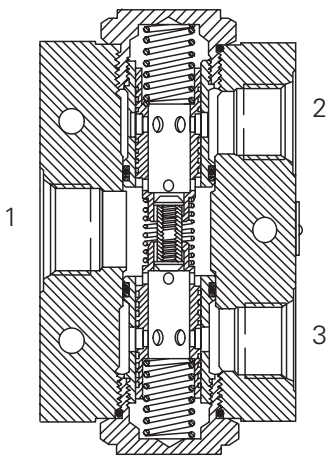

Pressure Drop Curves

Flow Division

(See model code position 5)

- A - 33 spool
- B - 44 spool
- C - 66 spool
- D - 88 spool

