

EATON

Vickers

Solenoid Operated Directional Valves

Catalog

DG4V3-70 Series

On-board electronics option

M12 cable connection



Table of Contents

Introduction	3
Model Code Definition	4
Functional Symbols, Spools.....	5
Operating Performance	6
Pressure Drop Performance	8
Electrical Specifications	9
Installation Dimensions	10
Manifolds	12
Companion Products	13
Available Parts and Recommended Models	14

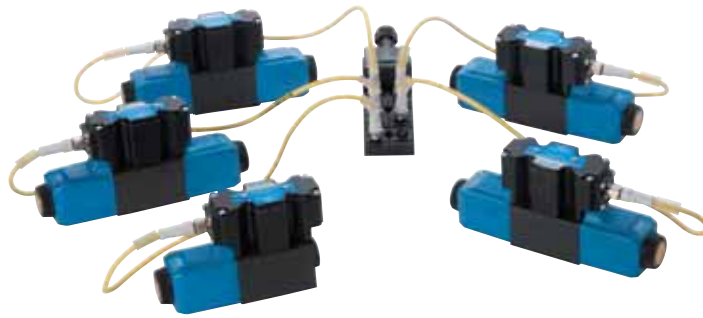

Above: DG4V3-70 single and double solenoid valves.

Right: Manifold assembly. Total solution: Valves, cables and junction block



Electrical components: Connector block and cable sets are described in this catalog section "Companion Products" page 13.



This product has been designed and tested to meet specific standards outlined in the European Electromagnetic Compatibility Directive (EMC) 89/336/EEC, amended by 91/263/EEC, 92/31/EEC and 93/68/EEC, article 5. For instructions on installation requirements to achieve effective protection levels, see this leaflet and the Installation Wiring Practices for Vickers™ Electronic Products leaflet 2468. Wiring practices relevant to this Directive are indicated by Electromagnetic Compatibility (EMC).

Introduction

1. Product introduction and target applications

DG solenoid valves are used in hydraulic circuits to start, stop and direct flow. With electronics on board, the DG4V3-Z-70 enables new machine control solutions, eliminating solenoid power shifting in the controls cabinet.

The DG4V3 – 70 series valve takes advantage of contemporary electronics and wiring practices applied in automation solutions world wide. Using industry standard M12 connectors and with the optional on board switching amplifier the –70 offers OEMs and users opportunity to simplify the electronics, and increase throughput by specifying preassembled and pre-wired electro-hydraulic manifold assemblies as shown on the previous page. This valve with on-board electronics has passed water immersion tests, qualified to IP67, and EMC testing to CE requirements. The rugged construction, designed and qualified by Eaton with key features such as plug in coils, M12 connector and multiple coil wattages, meeting major automotive plant specifications, makes this valve a natural for global projects.

This solenoid valve is the latest in a long line of recognized Vickers brand DG valves. The – 70 builds on the proven – 60 valve design, adding connectivity and functionality tailored for state of the art 24 VDC machine control system.

This product is available from and supported by Eaton and an extensive network of qualified distribution partners world wide.

2. Functional description

Electronics are housed in a robust metal housing sealed to IP67 environmental ratings and meeting CE standards for Electromagnetic Compliance.

- **Standard features** include surge suppression and LED's indicating voltage to the active coil.
- **The "Z" option adds the switching amplifier on board**, eliminating the cost and heat associated with having this function in the machine controls cabinet. 24 VDC power is supplied separately to pin1 of the M12 connector, while pin 2 or 4 control the solid-state switch connection to either solenoid A or B. Pin 3 is common.

3. Summary Features and Benefits

Hydraulic

Mounting interface: ISO 4401 size 03, ANSI/B93.7M size 3, CETOP RP65H, size 3, DIN 24340, NG 6

Maximum pressure: 350 bar (5075 psi) P, A and B ports.
210 bar (3000 psi) T port

Maximum flow: up to 80 l/m (21 USgpm) depending on spool type and coil wattage.

Environmental

IP 65 rated protection from low pressure water jets from all directions.

IP 67 rated, water immersion tested.

EMC qualified to EN 61326

CE certified, CE mark on the valve.

Electrical

- 24 VDC operation only
- M12 connection.
- Coil control options, described on page 9:
 - A-option, direct connection from the M-12 connector to each coil. (Model code pos 15)
 - Z-option, On Board Switching amplifier.

Information on available coil power levels and commands required to operate the on board switching amplifier is in section 5, Technical Specifications.

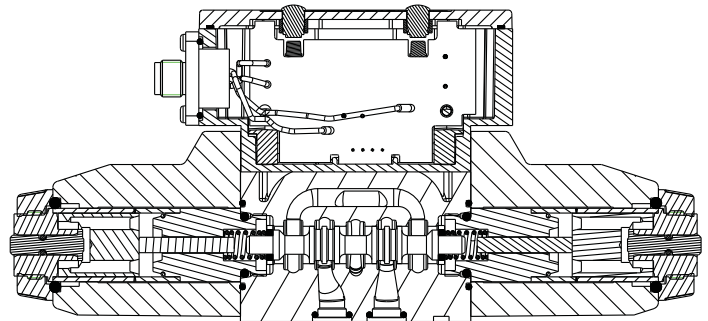

Cross Sectional View

Model Codes

DG4V3-70

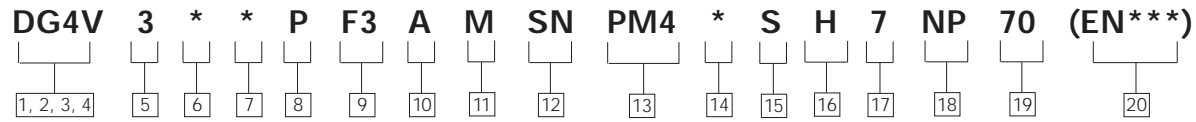

1 2 3 4 Directional Control Valve

DG4V - Subplate-mounted, solenoid-operated directional control valve.

350 bar on P, A & B Ports

5 ISO Number

3 - ISO 4401-AB-03-4-B with location pin

6 Spool Type

See "Functional Symbols" Section on page 5

7 Spool/Spring Arrangement

Single solenoid models

A - Spring offset, Right hand build (standard)

AL - Spring offset, Left hand build (optional)

F - Spring offset shift to center, Right hand build (standard). Not available with HM coil.

FL - Spring offset shift to center, Left hand build (optional). Not available with HM coil.

B - Spring centered, Right hand build (standard)

BL - Spring centered, Left hand build (optional)

Dual solenoid models

C - Spring centered. No R or L option

N - No spring detented. No R or L option.

8 Manual Override Option

P - Plain overrides in solenoid ends only (standard)

H - Waterproof override in solenoid ends only

H2 - Waterproof override in both ends of single solenoid

P2 - Plain override in both ends of single solenoid models

W - Twist and lock manual override (not available in "F6" models)

Z - No overrides in either end

9 Seal Type

F3 - Viton Seals (standard)

F6 - Nitrile Seals for Water Based Fluids

10 Solenoid Energization Identity

A - Solenoid identification based on ANSI B93 9 (i.e. energize solenoid A TO GIVE flow P to A) (standard)

V - Solenoid identification determined by position of solenoid (i.e. solenoid 'A' at port 'A' end, solenoid 'B' at port 'B' end). Required for 8C-type spool.

11 Electrical Flag

12 Spool Indicator Switch

SN - No Switch (standard)

S6 - LVDT style switch.

Single solenoid valve only. (Not yet available. To be released on request.)

13 Electrical Connector

PM4 - 4 Pin M12 Connector

14 Wiring Convention

A - Pins 2, 3 & 4 direct connection used

Z - On board switching amplifier

15 Configuration

S - Standard configuration (diodes and lights included)

16 Coil Identification

H - 24 VDC, 30W

HL - 24 VDC, 18W

HM - 24 VDC, 10W

17 Tank Pressure Rating

7 - 210 Bar

18 Port Orifice Plugs

NP - No Port Orifices (standard)

P** - Orifice in "P" port

A** - Orifice in "A" port

B** - Orifice in "B" port

T** - Orifice in "T" port

Sizes (the "****" above):

03 - 0.30 orifice dia

06 - 0.60 orifice dia

08 - 0.80 orifice dia

10 - 1.00 orifice dia

13 - 1.30 orifice dia

15 - 1.50 orifice dia

20 - 2.00 orifice dia

23 - 2.30 orifice dia

25 - 2.50 orifice dia

30 - 3.00 orifice dia

35 - 3.50 orifice dia.

19 Design Number

70 - Design Number

20 Special Modifications

Omit - If not required

Functional Symbols, Spools

Available spool options

(illustrated to the right)
Configurations include 3-position and 2-position, spring centered, spring off-set and no-spring detented.

The valve function schematics apply to both U.S. and European valves.

DG4V-3-*N(V)

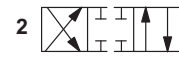

DG4V-3-*A(V)



DG4V-3-*AL(V)



DG4V-3-*C(V)

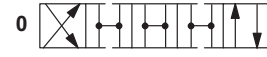

DG4V-3-*B/F(V)



DG4V-3-*BL/FL(V)

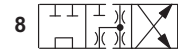
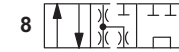
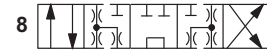
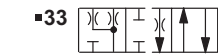
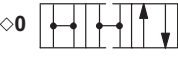

Solenoids identified to U.S. standards

(specify "A" in model code)

Functional symbols related to solenoid identity "A" and/or "B" according to NFPA/ANSI standards, i.e. energizing solenoid "A" gives flow P to A, solenoid "B" gives flow P to B (as applicable).

Location of solenoid "A" or "B" shown relative to the hydraulic work port.

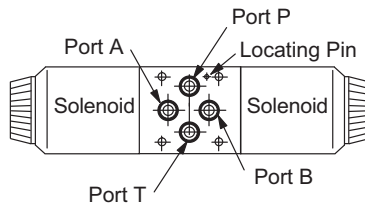

Solenoid	For Use with Spool Type	Solenoid
B	All except "8"	A
A	"8" only	B

"A" and "B" designations are printed on the name label adjacent to the solenoid indicator lights, illustrated above.

Double solenoid valves, two position, detented

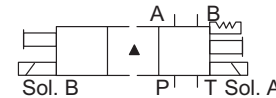

Double solenoid valves, spring centered

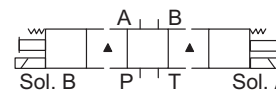

▲ Transient condition only

Single solenoid valves, solenoid at port A end

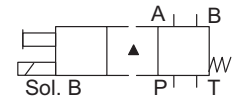

Single solenoid valves, solenoid at port B end

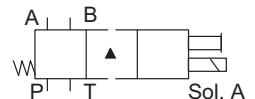

Solenoids identified to European standards

(specify "V" in model code)

Functional symbols related to solenoid identity "A" and/or "B" according to European convention i.e. solenoid "A" adjacent to "A" port, solenoid "B" adjacent to "B" port of valve.

Location of solenoid "A" or "B" shown relative the hydraulic work port.

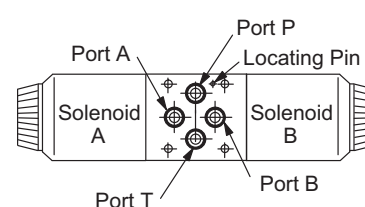

Solenoid	For Use with Spool Type	Solenoid
B	All spools	A

"A" and "B" designations are printed on the name label adjacent to the solenoid indicator lights, illustrated below.

Double solenoid valves, two position, detented

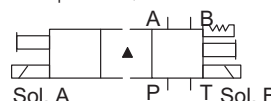

Double solenoid valves, spring centered

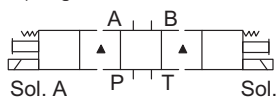

▲ Transient condition only

Single solenoid valves, solenoid at port A end

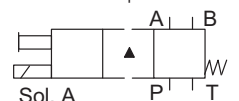

Single solenoid valves, solenoid at port B end

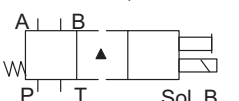

Operating Performance

Flow limit curves are subject to the following conditions:

The maximum flow curves assume simultaneous and equal flow rates. Single flow paths or applications with substantial differential flows or with large compressed volumes of oil, 2000 ccm (122 cm³) should be subjected to analysis beyond the maximum flow curves in this catalog.

Performance data typical under standard test conditions which use antiwear hydraulic oil (Class L-HM) at 21 cSt (102 SUS) and 50°C (122°F).

H Type Solenoid- 30W

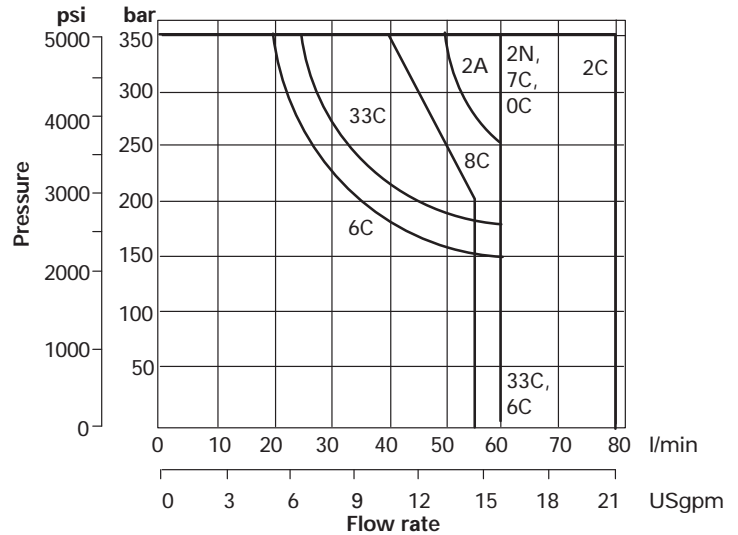

HL Type Solenoid- 18W- (Optional)

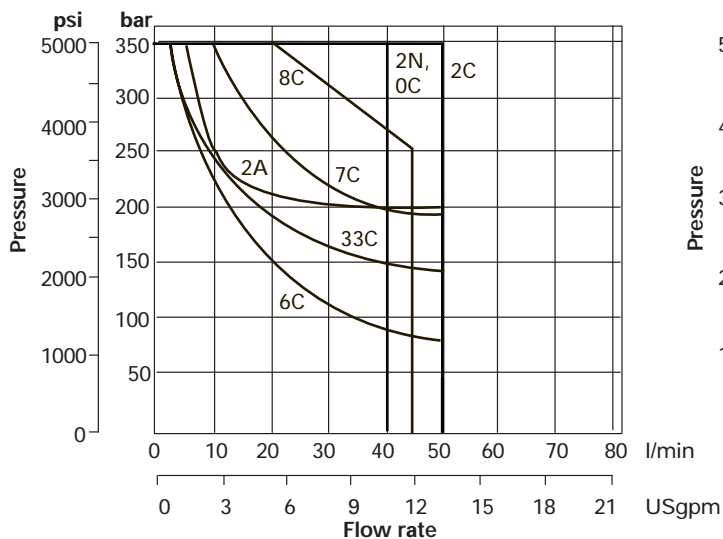

HM Type Solenoid- 10W- (Optional)

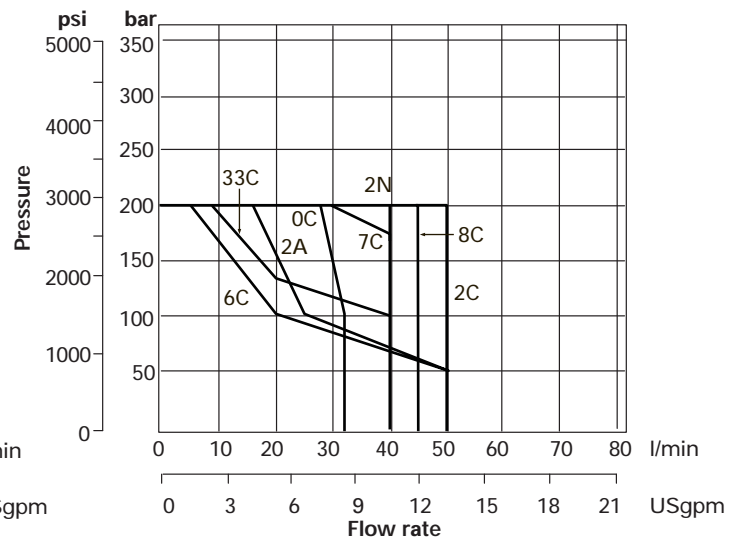

Coil ratings

Voltage: "H" 24 VDC only. Optional H (30W), HL (18W) and HM (10W).

Maximum flow performance is based on coils stabilized at high temperature (continuously subjected to 90% of rated voltage) and operated at 90% of rated 24 VDC voltage. Test fluid is mineral based oil at 36 cSt (168.8 SUS) and 0.87 specific gravity.

Solenoid Power Level by Coil Option

COIL TYPE	RATED POWER ¹	RATED CURRENT ¹	HOT CURRENT ²
"H"	30W	1.20 A	950 mA
"HL"	18W	800 mA	670 mA
"HM"	10W	430 mA	370 mA

¹ Solenoid at 20°C (68°F) and nominal 24 VDC

² Solenoid at "high" temperature, stabilized at 24 VDC

Operating Performance

OPERATING DATA:

Pressure Limits			
P, A and B ports	350 bar (5075 psi)		
T port	210 bar (3045 psi)		
Flow Rating	Up to 80 l/min, see Flow limit curves on page 6.		
Relative Duty Factor	Continuous; ED= 100%		
Type of Protection	IEC 144 class IP67		
Coil Winding	NEC class H		
Coil Encapsulation	NEC class F		
Permissible Voltage Fluctuation			
Range	24 VDC +/- 10%		
Typical response time at 100% rated volts measured from application/removal of voltage to full displacement of 2C spool at:			
Coil Designation	H	HL	HM
Flow Rate P-A, B-T	40 l/m (10.6 Usqpm)	25 l/m (6.6 Usqpm)	25 l/m (6.6 Usqpm)
Pressure	175 bar (2600 psi)	175 bar (2600 psi)	100 bar (1500 psi)
DC (=) energizing	60 ms	65 ms	85 ms
DC (=) de-energizing	33	40	40
Power consumption, DC solenoids at rated voltage and 20 C (68 F).			
Full power coils:			
24V, model type "H"	30W		
Low power coils:			
24V, model type "HL"	18W		
24V, model type "HM"	10W		
Weight			
Double solenoid	2.5 kg (5.5 lb) approx.		
Single solenoid	1.9 kg (4.2 lb) approx.		
Fluid cleanliness	19/17/14		
Temperature			
Fluid	-20 to + 70°C (-4 to +158°F)		
Ambient air	-20 to + 70°C (-4 to +158°F)		
Storage	-25 to + 85°C (-13 to +185°F)		

Pressure Drop Performance

Pressure Drop Curves by Spool Type

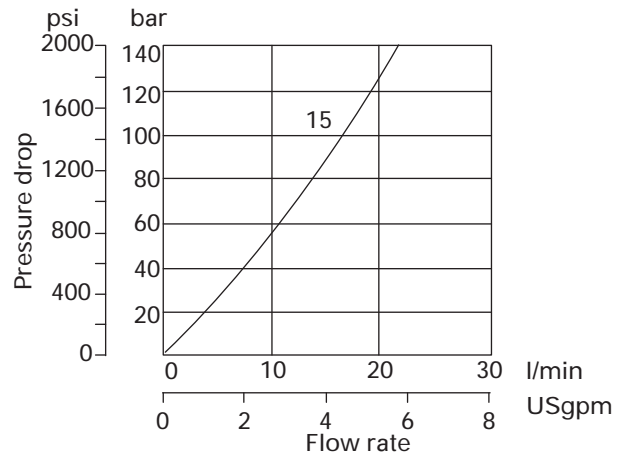
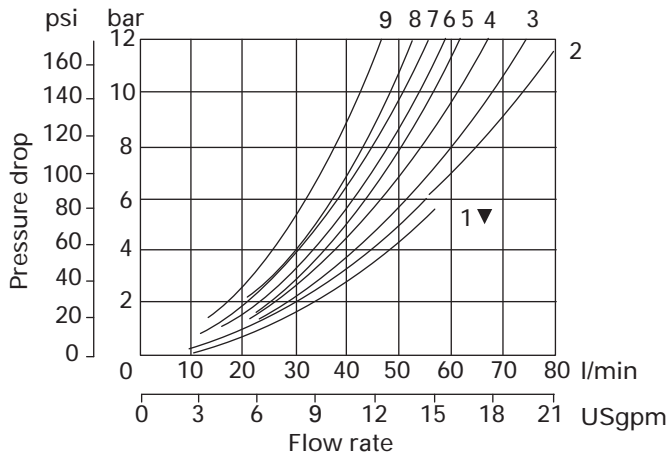

▼ Curve for spool type 6: not recommended for flows in excess of 60 l/min (15.8USgpm).

Pressure drops in offset positions except where otherwise indicated.

Spool/Spring Code	Covered Spool Positions	P-A	P-B	A-T	B-T	P-T	B-A or A-B
0A(L)	Both	5	5	2	2	-	-
0B(L) & 0C, 0F	De-energized	-	-	-	-	4▲■	-
	Energized	4	4	2	2	-	-
2A(L)	Both	6	6	5	5	-	-
2B(L), 2C, 2F	Energized	5	5	2	2	-	-
2N (H and HL coil)	Both	6	6	3	3	-	-
2N (HM coil)	Both	8	8	5	5	-	-
6B(L), 6C, 6F	De-energized	-	-	3▲	3■	-	-
	Energized	6	6	1	1	-	-
7B(L), 7C, 7F	De-energized	6▲	6■	-	-	-	7○
	Energized	4	4	3	3	-	-
8B(L), 8C	All	9	9	5	5	3	-
33B(L), 33C	De-energized	-	-	15▲	15■	-	-
	Energized	5	5	2	2	-	-

▲ "B" plugged ■ "A" plugged ○ "P" plugged

For other viscosities, pressure drops approximate to:

Viscosity cSt (SUS)

14	20	43	54	65	76	85
(17.5)	(97.8)	(200)	(251)	(302)	(352)	(399)

% of Δp

81	88	104	111	116	120	124
----	----	-----	-----	-----	-----	-----

A change to another specific gravity will yield an approximately proportional change in pressure drop.

The specific gravity of a fluid may be obtained from its producer. Fire resistant fluids usually have higher specific gravities than oil.

Electrical Specifications

Solenoid Indication Standard

LED is lit when there is power to the coil.

EMC Qualifications

to EN 61326

A-Option

Direct connected coil shown to the right.

Protection network for inductive loads protects the (machine control) switch from high voltages and speeds the de-energizing of the solenoid.

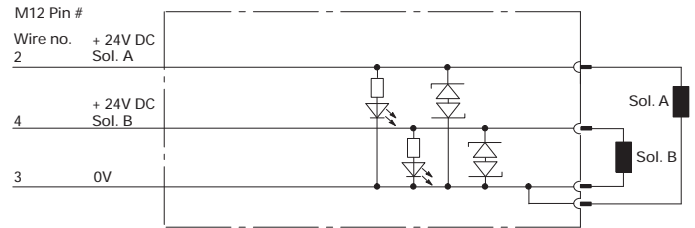

Z-Option

Switching Amplifier on Board shown to the right.

The circuit on the Z-option is reverse polarity protected. The output is short circuit protected. In case of a shorted solenoid, the amplifier will remove the voltage from it. When the short is removed the amplifier will restart automatically.

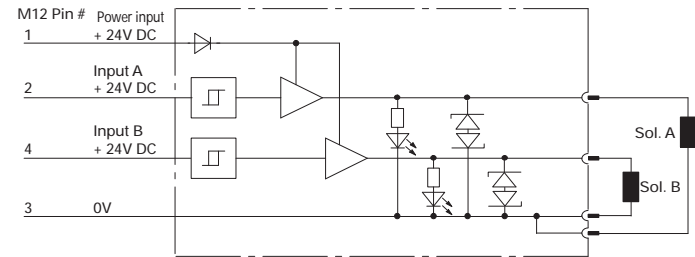

ELECTRICAL DATA:

For the "Z" option, switching amplifier version.

Power Supply	24 VDC +- 10 % range
Control input	Per IEC 61131-2 for digital input type 2
Switching Frequency	2 Hz maximum
Range	-2 to +30V
ON condition	11 V and above. 6 mA at 11 V. Maximum 20 mA at 24 V
OFF condition	5 V and below. 2 mA at 5 V.

M12 Connection

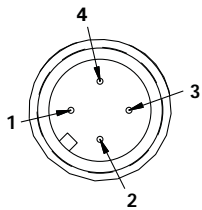

Pin 1 is only used on the Z option for 24 VDC power to the valve.

Pin 2 always controls ("Z" option) or power ("A" option) the solenoid on the "B" port side of the valve.

Pin 3 is always common or 0 volt, both A and Z control option.

Pin 4 always controls ("Z" option) or power ("A" option) the solenoid on the "A" port side of the valve.

CONTROL OPTION	PIN NUMBER	CONNECTION REF DESTINATION
PM4AS	1	No Connection
"A" Option	2	Power, Solenoid on B-Port Side
	3	Common, Sol A & B-
	4	Power, Solenoid on A-Port Side
	1	Power Supply
PM4ZS	2	Control Input, Solenoid on B-Port Side
	3	Common, 0V
"Z" Option	4	Control Input, Solenoid on A-Port Side

Note: For left hand builds ("L" in model code pos 8) pin connection to port A and B will be reversed.

WARNING: Electromagnetic Compatibility (EMC)

It is necessary to ensure that the valve is wired up in accordance with the connection arrangements shown in this leaflet.

For effective protection, the user's electrical cabinet, the valve subplate or manifold and the cable screens should be connected to efficient ground points.

In all cases, both valve and cable should be kept as far away as possible from any source of electromagnetic radiation such as cables carrying heavy current, relays and certain kinds of portable radio transmitters, etc.

Difficult environments could mean that extra screening may be necessary to avoid interference.

Installation Dimensions

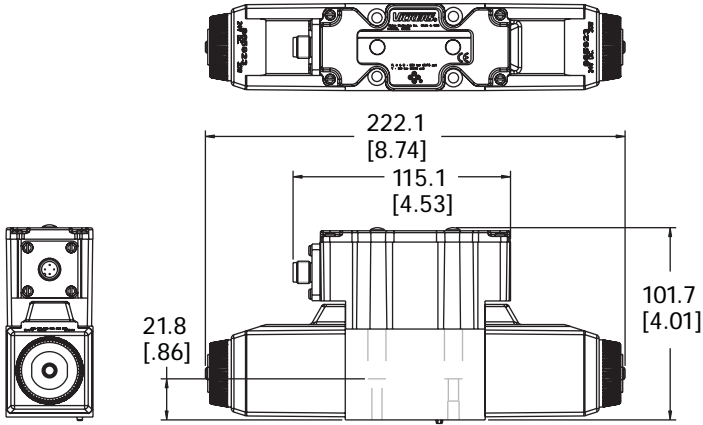

DG4V-3-***C/N**-*M-PM4*S-***7-70

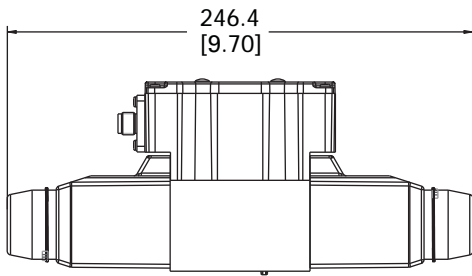

DG4V-3-***C/N-H**-*M-PM4*S-***7-70

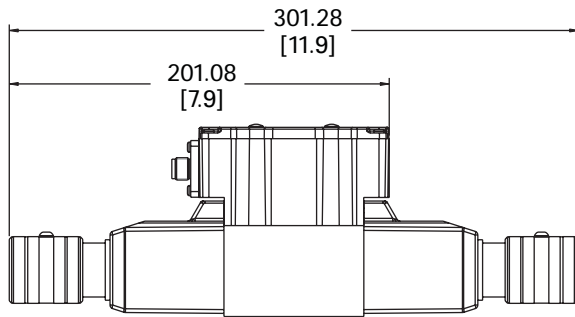

DG4V-3-***(L)-**W**-*M-PM4*S-***7-70

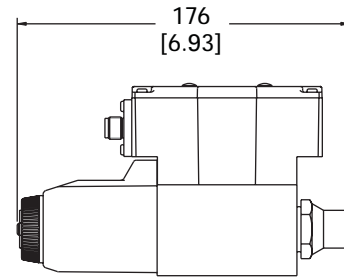

DG4V-3-***A/B/F(L)-**P2**-*M-PM4*S-***7-70

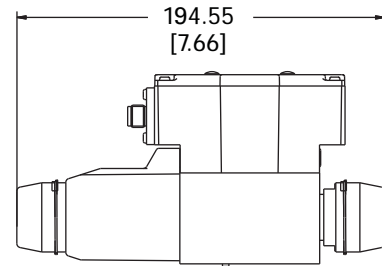

DG4V-3-*A/B/F(L)-**H2**-*M-PM4*S-***7-70

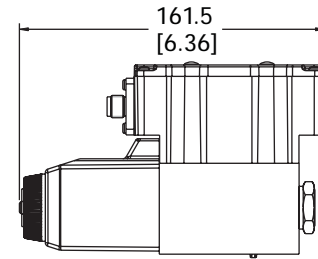

DG4V-3-***A/B/F(L)**-*M-PM4*S-***7-70

Installation Dimensions

Dimensions in mm(in).

Single station subplates, rear and side tapped ports.

MODEL	PORTS P, A, T, B AT REAR OR SIDE	THREAD
DGVM-3-1*-R	Rear	G 3/8 (3/8" BSPF) x 12,0 (0.47) deep
DGMS-3-1E-1*-R	Side	
DGVM-3-1*-S	Rear	3/4" 16 UNF-2B x 14,3 (0.56) deep (SAE)
DGMS-3-1E-1-S*	Side	
DGMS-3-1EY-1-S*	Side	5/8" 18 UNF-2B x 12,7 (0.5) deep (SAE)

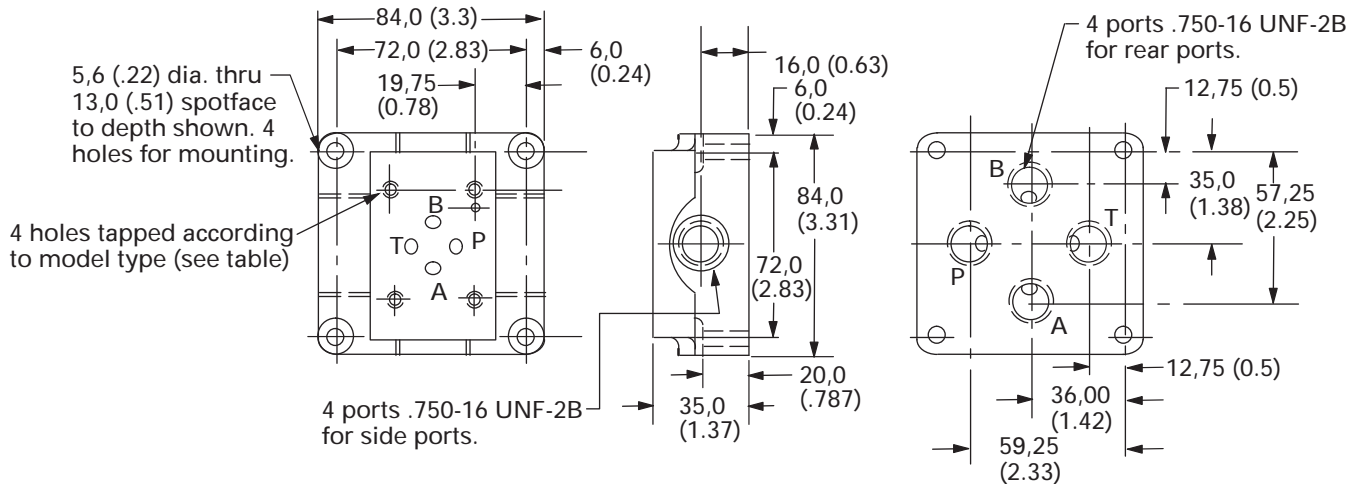
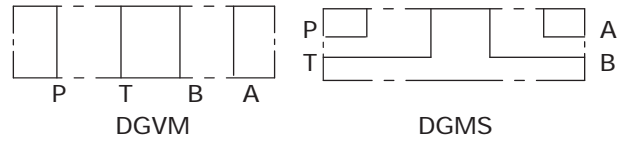

When a subplate is not used, a machined pad must be provided for mounting. The pad must be flat within 0,01 mm per 100 mm (0.0001" per 1") and smooth within 0,8 Egm (32 Egin).

The interface conforms to ISO 4401-AB-03-4A (size 03) plus location pin hole ANSI/B93.7M (and NFPA) size 03 CETOP R35H4.2-03, plus location pin hole DIN 24340 Form A6, plus location pin hole

Dimensional tolerance = 0,2 (0.008) except where otherwise stated.

Prior to installing a valve, ensure that both valve and mounting surface are clean and free from burrs.

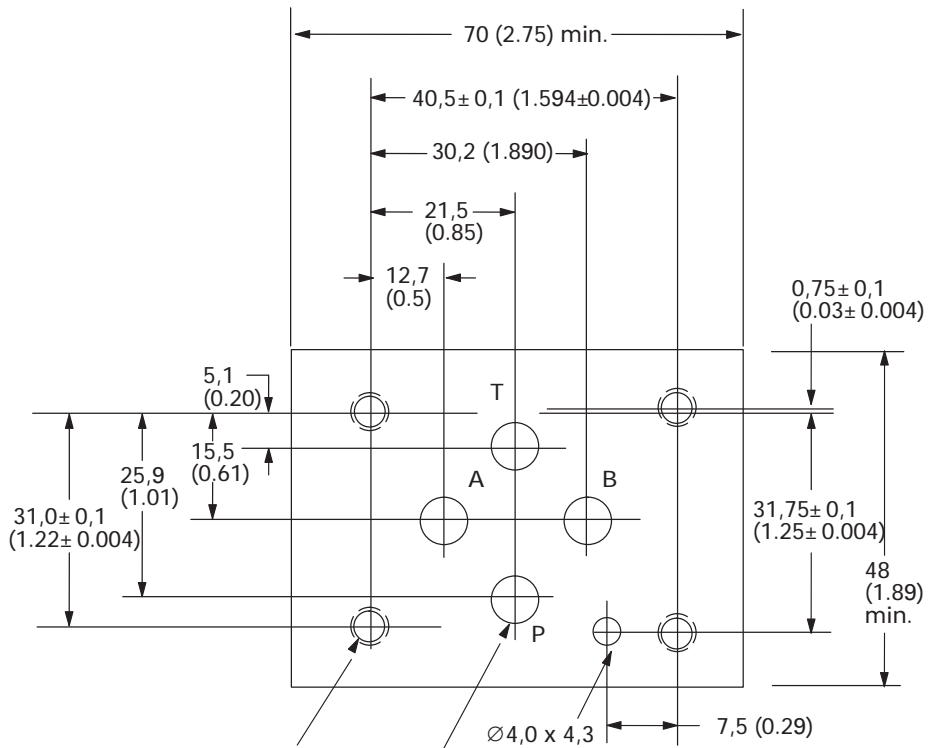

- ▲ 4 holes, M5-6H x 12,0 (0.47) min. full thread depth
- 4 ports $\varnothing 6,3$ (0.25 dia). For all Vickers size 3 valves this diameter may be increased to $\varnothing 7,5$ (0.29 dia).

$\varnothing 4,0 \times 4,3$ min. deep (0.16 dia x 0.17 deep) for locating pin

▲ ISO 4401 gives dimensions in mm. Inch conversions are accurate to 0.01" unless stated.

■ #10-24 UNC-2B optional

Manifolds for 2, 3, 4, 5 and 6 valve stations.

MODEL	A DIM.	B DIM.
DGMS-3-2E(X)-1*-*	121 (4.8)	108 (4.25)
DGMS-3-3E(X)-1*-*	171 (6.8)	158 (6.22)
DGMS-3-4E-1*-*	221 (8.7)	208 (8.19)
DGMS-3-5E-1*-*	271 (10.7)	258 (10.15)
DGMS-3-6E-1*-*	321 (12.7)	308 (12.12)

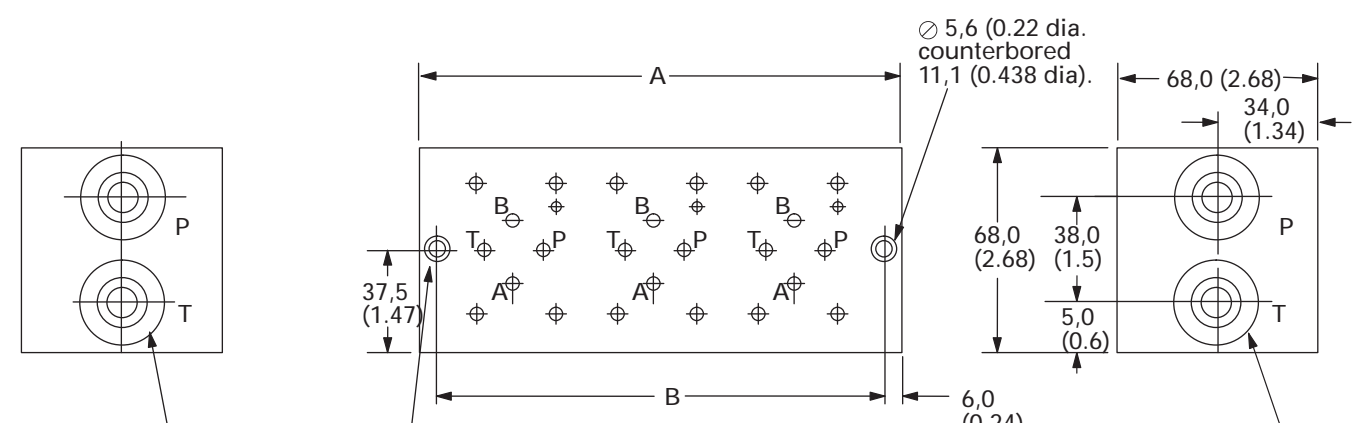
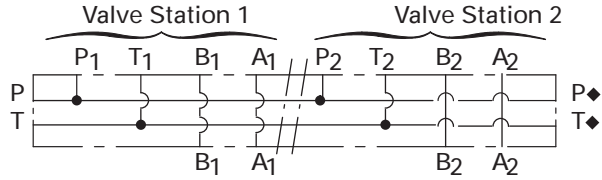

These two ports are present in 4, 5, and 6 station models. Optional in 2 and 3 station models, specify DGMS-3-2EX-1*-* or DGMS-3-3EX-1*-*

4 holes per model type
BSPF ports: M5-6H x 12,0 (0.47) deep
SAE ports: #10-24 UNF-2B x 12,5 (0.5) deep

P and T ports tapped according to model type:
DGMS-*E(X)-1*-R:
G1/2 (1/2" BSPF)
DGMA-*E(X)-1*-S:
3/4:-16 UNF-2B (SAE)

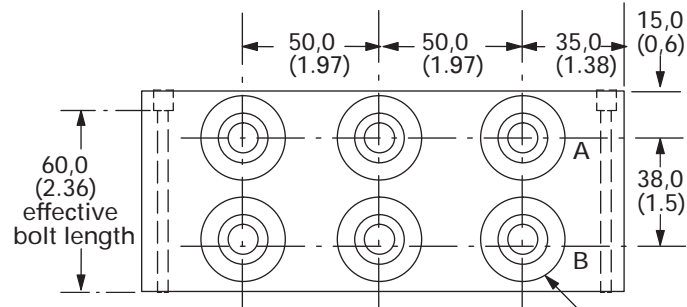

A and B ports tapped according to model type:
DGMS-*E(X)-1*-R:
G3/8 (3/8" BSPF)
DGMA-*E(X)-1*-S:
3/4:-16 UNF-2B (SAE)

◆ Thru connection P and T ports on types DGMS-3-2EX-1*-* and DGMS-3-3EX-1*-*

Companion Products

Companion products
(Can be ordered on the same order and shipped with the valves)

CONNECTOR BLOCKS FOR 24 VDC OPERATION.

M12 4-PIN PORT CONNECTIONS AND CONFIGURABLE SCREW TERMINAL CONNECTION FOR THE MASTER CABLE.

Vickers P/N	Model description	Outlets
02-396529	CBDR4PSC-D	4
02-396530	CBDR6PSC-D	6
02-396531	CBDR8PSC-D	8

Current ratings: Each pin 2 amp, each port 4 amp max. Block maximum 12 amp.

M12 4-PIN MALE TO FEMALE CABLE SETS WITH STRAIGHT ENDS. 4 WIRE 22 AWG

PUR jacket, IP67 rated

Vickers P/N	Model description	Length
02-396533	CSDS4A4RY220.4-D	0.4 M (16 inch)
02-396534	CSDS4A4RY220.6-D	0.6 M (24 inch)
02-396535	CSDS4A4RY2201-D	1.0 M (36 inch)
02-396536	CSDS4A4RY2202-D	2.0 M (79 inch)

Hydraulic Accessories

DGVM-3-1*-*

DGMS-3-1E(Y)-1*-*

Single station sub-plate, rear and side tapped ports

Bolt kits

BK590716:
M5X30 mm

BK590716:
#10-24 x 31.5 mm (1.25 in)

Available Parts and Recommended Models

Parts available for sale:

SEAL KITS:

F-3 Viton seals, standard:	02-397447
F-6 Seal option for water glycol fluids:	02-397448

COILS, ALL 24 VDC:

H, 30-watt full power:	865923
HL, 18-watt low power:	865963
HM, 10-watt reduced power:	02-365173

Note: Solenoid power affects spool shifting force and hydraulic performance. Only the 30-watt full power solenoid provides full flow ratings and extra shifting force to overcome potential spool sticking associated with oil contamination and silting.

TWIST AND LOCK MANUAL OVERRIDE

W -shown below (not available in "F6" models)	02-411819
---	-----------

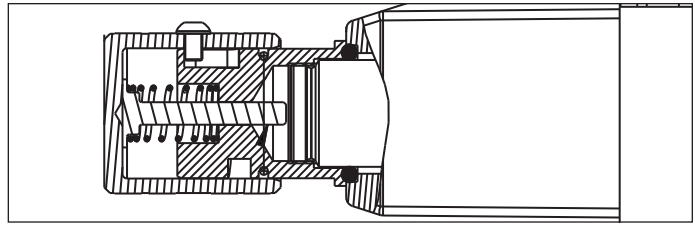

RECOMMENDED MODELS AND RELEASED ASSEMBLY NUMBERS:

30 W Direct connected coils:

02-397816	DG4V-3-0B-P-F3-AM-SN-PM4AS-H7-NP-70
02-397800	DG4V-3-2A-P-F3-AM-SN-PM4AS-H7-NP-70
02-397811	DG4V-3-2C-P-F3-AM-SN-PM4AS-H7-NP-70
02-397817	DG4V-3-2N-P-F3-AM-SN-PM4AS-H7-NP-70
02-397818	DG4V-3-33C-P-F3-AM-SN-PM4AS-H7-NP-70
02-397812	DG4V-3-6C-P-F3-AM-SN-PM4AS-H7-NP-70

30 W On board switching amplifier:

02-397819	DG4V-3-0B-P-F3-AM-SN-PM4ZS-H7-NP-70
02-397810	DG4V-3-2A-P-F3-AM-SN-PM4ZS-H7-NP-70
02-397804	DG4V-3-2C-P-F3-AM-SN-PM4ZS-H7-NP-70
02-397820	DG4V-3-2N-P-F3-AM-SN-PM4ZS-H7-NP-70
02-397850	DG4V-3-33C-P-F3-AM-SN-PM4ZS-H7-NP-70
02-397813	DG4V-3-6C-P-F3-AM-SN-PM4ZS-H7-NP-70

RECOMMENDED MODELS AND RELEASED ASSEMBLY NUMBERS:

18 W Direct connected coils:

02-397821	DG4V-3-0B-P-F3-AM-SN-PM4AS-HL7-NP-70
02-397822	DG4V-3-2A-P-F3-AM-SN-PM4AS-HL7-NP-70
02-397823	DG4V-3-2C-P-F3-AM-SN-PM4AS-HL7-NP-70
02-397824	DG4V-3-2N-P-F3-AM-SN-PM4AS-HL7-NP-70
02-397851	DG4V-3-33C-P-F3-AM-SN-PM4AS-HL7-NP-70
02-397852	DG4V-3-6C-P-F3-AM-SN-PM4AS-HL7-NP-70

18 W On board switching amplifier:

02-397853	DG4V-3-0B-P-F3-AM-SN-PM4ZS-HL7-NP-70
02-397854	DG4V-3-2A-P-F3-AM-SN-PM4ZS-HL7-NP-70
02-397855	DG4V-3-2C-P-F3-AM-SN-PM4ZS-HL7-NP-70
02-397856	DG4V-3-2N-P-F3-AM-SN-PM4ZS-HL7-NP-70
02-397857	DG4V-3-33C-P-F3-AM-SN-PM4ZS-HL7-NP-70
02-397858	DG4V-3-6C-P-F3-AM-SN-PM4ZS-HL7-NP-70

10 W Direct connected coils:

02-397859	DG4V-3-2A-P-F3-AM-SN-PM4AS-HM7-NP-70
02-397860	DG4V-3-6C-P-F3-AM-SN-PM4AS-HM7-NP-70

Two stage solenoid valves with DG4V3-70 series pilot are available on request. The following models are listed for reference:

02-411881	DG5V-5-6C-M-PM4AS-H7-10
02-411924	DG5V-5-2A-M-PM4AS-HL7-10
02-411925	DG5V-5-2C-M-PM4AS-HL7-10
02-411927	DG5V-5-2N-M-PM4AS-HL7-10
02-411928	DG5V-5-6C-M-PM4AS-HL7-10
02-411929	DG5V-5-33C-M-PM4AS-HL7-10

Eaton
14615 Lone Oak Road
Eden Prairie, MN 55344
USA
Tel: 952 937-9800
Fax: 952 974-7722
www.hydraulics.eaton.com

Eaton
20 Rosamond Road
Footscray
Victoria 3011
Australia
Tel: (61) 3 9319 8222
Fax: (61) 3 9318 5714

Eaton
Dr.-Reckeweg-Str. 1
D-76532 Baden-Baden
Germany
Tel: (49) 7221 682-0
Fax: (49) 7221 682-788

