



Gear Pumps and Motors

Technical Catalog

Series 26 Pumps
Series 26 Motors
Series L2 Pumps



Table of Contents

Series 26 Pumps

Features	3
General Specifications and Performance Data	4
Performance Data Charts	5
Standard Catalog Assemblies - Dimensions	9
Order Numbers	10
Optional Configurations	12
Component Parts - Dimensions	13
Model Code - Single	16
Model Code - Multiple	17
Side-Load Applications	19
Load Sensing Priority Valve	21

Series 26 Motors

General (more information is to come)	22
---	----

Series L2 Pumps

General Specifications and Performance Data	23
Performance Data Charts	24
Standard Catalog Assemblies - Dimensions	26
Order Numbers	27
Optional Configurations	29
Component Parts - Dimensions	30
Model Code - Single	33
Model Code - Multiple	34

Series 26 Pump Features

Pressures to 3500 PSI
and flow to 24.1 GPM

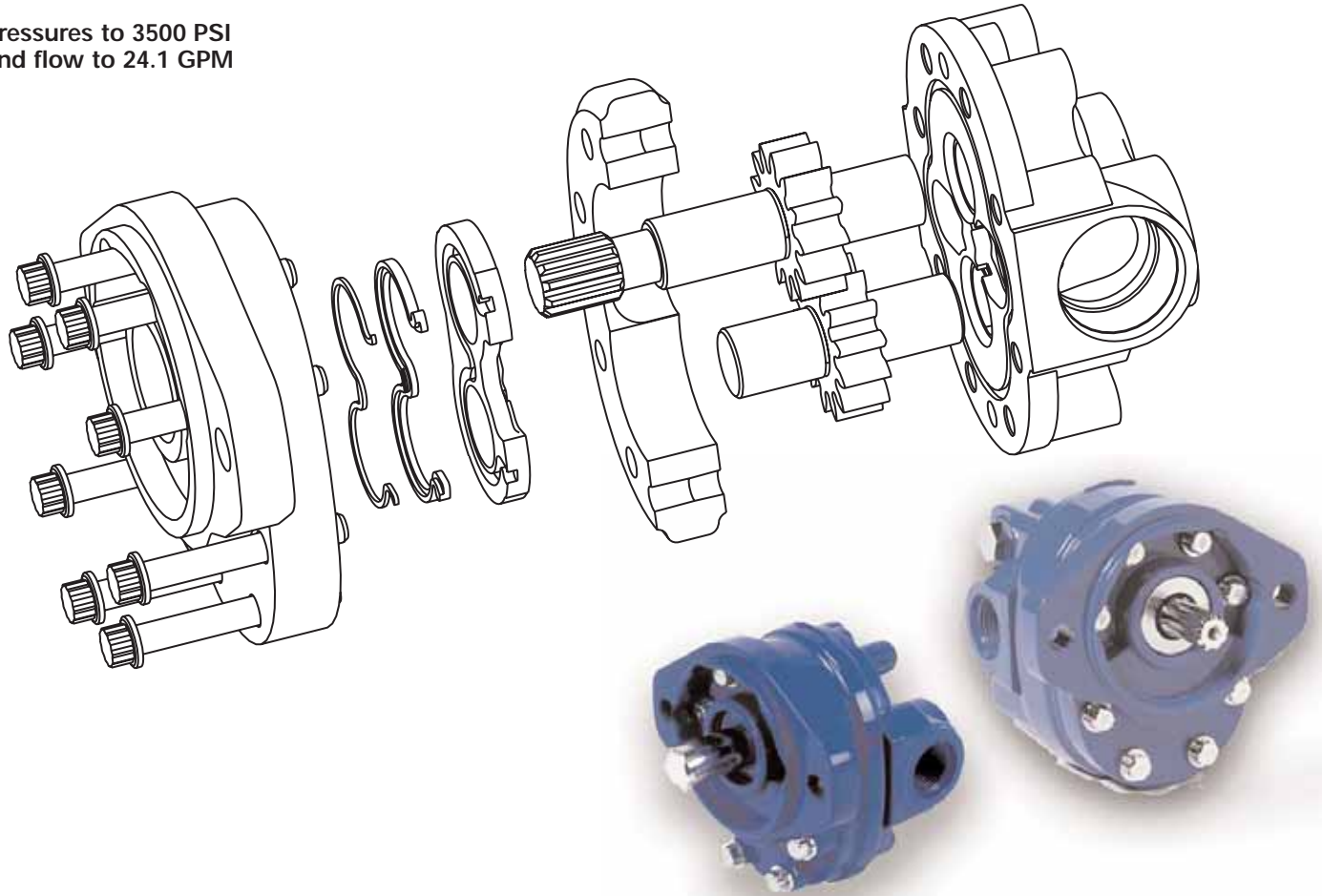

Quiet Operation

- The 13-tooth gears, versus 10 teeth in previous pumps, minimizes the flow ripple. This reduces noise as well as vibration.
- The improved trap reliefs not only increase power, they also help keep oil flowing smoothly to reduce noise.

Improved Efficiency

- Improved bearing lubrication system uses inlet oil instead of high pressure oil, improving volumetric efficiency for more power output.
- The highly polished shaft and gears improve mechanical efficiency and reduce wear on these components, adding to the service life and reliability of the pump.
- The optimized trapped oil relief areas help reduce pressure ripple for quieter operation. This also decreases the input power requirements.

Field Reversible

- The innovative new wear plate permits simple field reversibility of the pump direction. Simply open the pump, switch the drive gear and idler gear, reposition the plug and reassemble. No extra parts are needed.

Interchangeability

- The Series 26 Gear Pump has been designed to retrofit equipment using the B1 and B2 Gear Pumps. Extra shafts, porting, and mounting configurations, as well as 13 available displacements, give you the choices you need for an easy conversion to this superior pump.

Series 26 Pump

General Specifications and Performance Data

Rotation	Field Reversible
Mounting Flange	SAE A 2 Bolt
Max. Continuous Pressure†	210 bar [3000 PSI]*
Max. Intermittent Pressure††	240 bar [3500 PSI]**
Minimum Speed at Continuous Pressure	750 RPM
Maximum Rotating Torque at 0 Pressure	4 Nm [36 lb-in]
Maximum Continuous Operating Temperature	105°C [220°F]
Minimum Continuous Oil Viscosity	5.7 cSt [45 SUS]
Minimum Operating Temperature	-29°C [-20°F]
Maximum Inlet Vacuum at Operating Condition	0,8 bar Abs. [11.6 psi Abs.]

† Continuous - pump may be run continuously at these ratings.

†† Intermittent - intermittent operation, 10% of every minute.

* 30.6 cm³/rev. [1.87 in³/rev.] displacement max. continuous pressure is 190 bar [2750 PSI].

** 30.6 cm³/rev. [1.87 in³/rev.] displacement max. intermittent pressure is 224 bar [3250 PSI].

For side load limits consult your Eaton representative.

Displacement cm ³ /r [in ³ /r]	6,6 [.40]	8,2 [.50]	9,5 [.58]	10,8 [.66]	13,8 [.84]	16,7 [1.02]	19,7 [1.20]
Max. Intermittent Pressure bar [PSI]	241 [3500]	241 [3500]	241 [3500]	241 [3500]	241 [3500]	241 [3500]	241 [3500]
Rated Speed (RPM)	3600	3600	3600	3600	3600	3600	3200
Minimum Output Flow at 207 bar [3000 PSI] and Rated Speed LPM [GPM]	20,1 [5.3]	25,0 [6.6]	29,5 [7.8]	33,7 [8.9]	43,5 [11.5]	55,3 [14.6]	57,9 [15.3]
Input Power at 207 bar [3000 PSI] and Rated Speed and Cont. Pressure kW [HP]	9,7 [13.0]	11,9 [15.9]	14,1 [18.9]	15,5 [20.8]	20,0 [26.8]	22,0 [29.4]	26,2 [35.2]

Displacement cm ³ /r [in ³ /r]	22,5 [1.37]	24,3 [1.48]	25,2 [1.54]	27,7 [1.69]	29,0 [1.77]	30,6 [1.87]
Max. Intermittent Pressure bar [PSI]	241 [3500]	241 [3500]	241 [3500]	241 [3500]	234 [3400]	224 [3250]
Rated Speed (RPM)	3000	3000	3000	3000	3000	3000
Minimum Output Flow at 207 bar [3000 PSI] and Rated Speed LPM [GPM]	62,1 [16.4]	67,0 [17.7]	69,7 [18.4]	76,5 [20.2]	79,9 [21.1]	84,4 [22.3]
Input Power at 207 bar [3000 PSI] and Rated Speed and Cont. Pressure kW [HP]	27,3 [36.6]	30,5 [40.9]	31,0 [41.6]	33,4 [44.8]	35,4 [47.4]	37,4 [50.1]

The performance data in the table above and the following graphs was collected using a mineral base oil with a viscosity of 133 SUS at 49°C [120°F].

Ordering Information

Catalog Assemblies Cross Reference

Standard catalog assemblies are built from high production parts and are the most economical pump assemblies available in this series. The standard assembly

order number is a preassigned part number and may be used to order the specific standard assembly (see pages 10–13). The far right column lists the B1 or B2 pump replaced by the Series 26 pump.

Series 26 Pump Performance Data

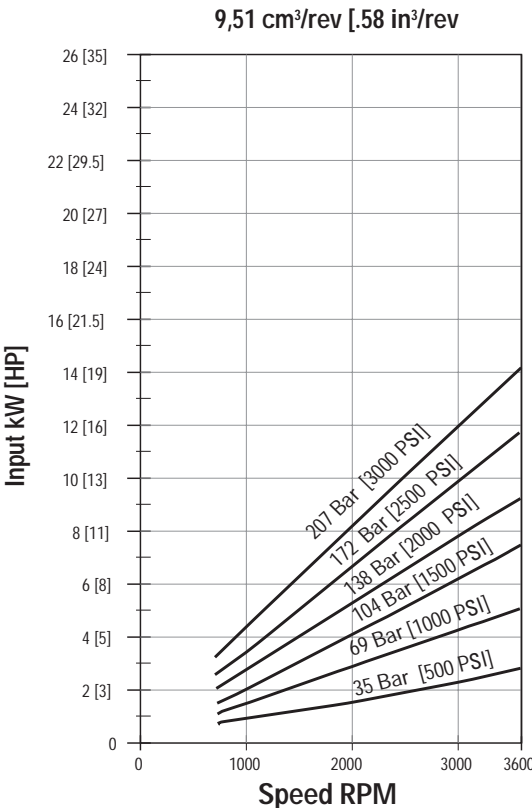
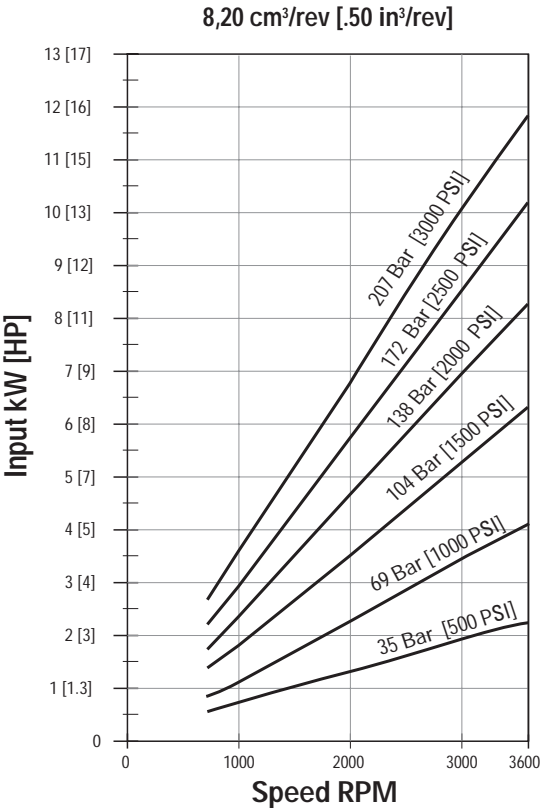
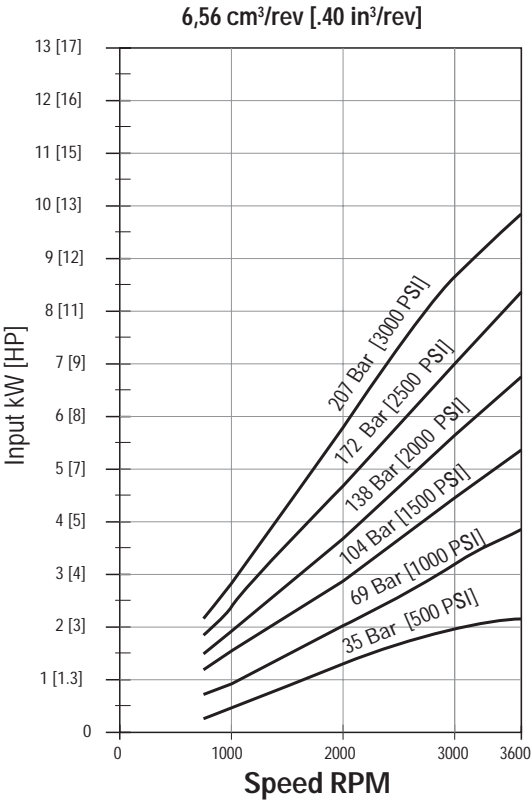
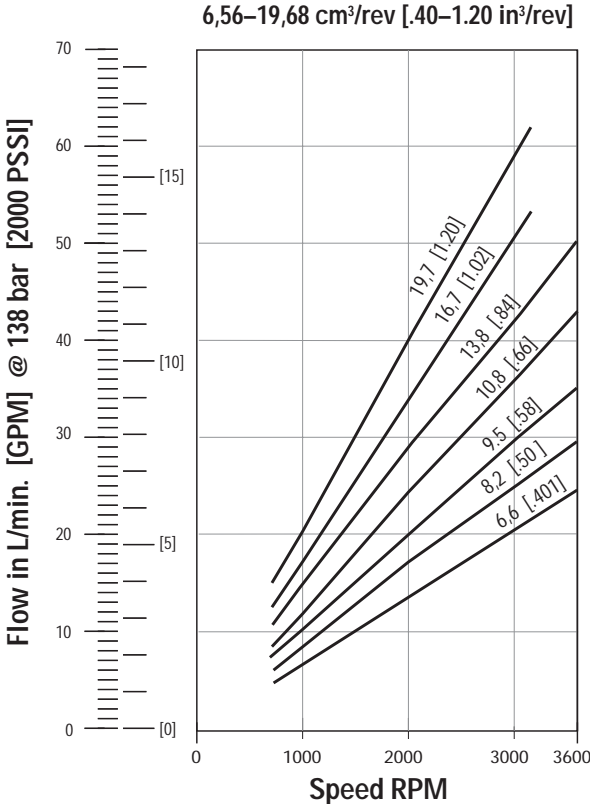

Series 26 Pump Performance Data

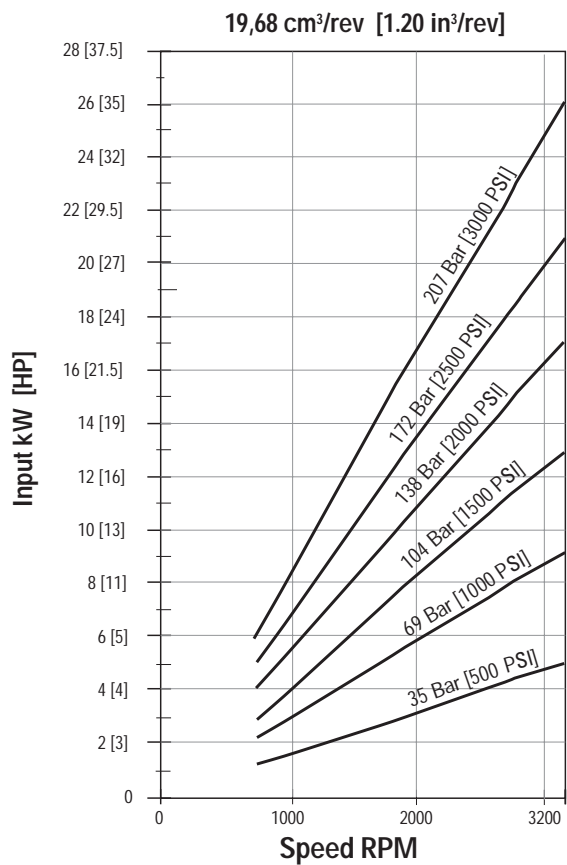
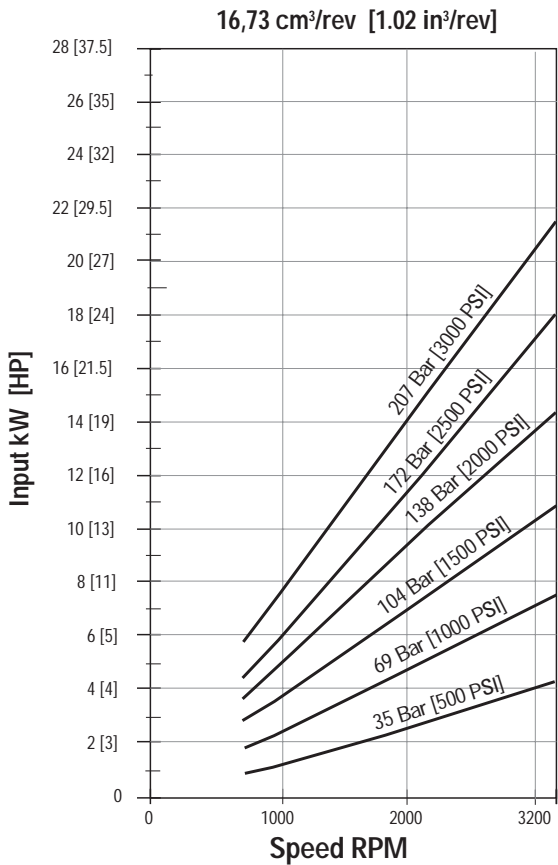
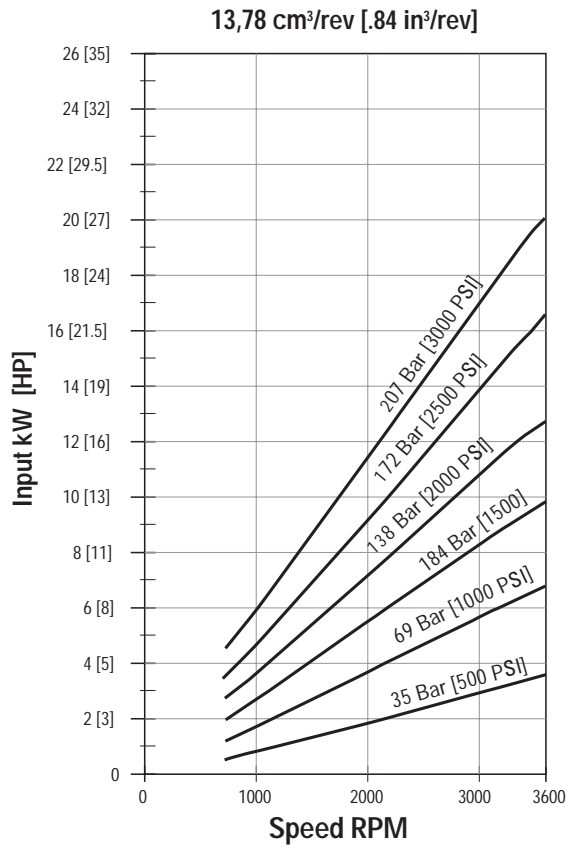
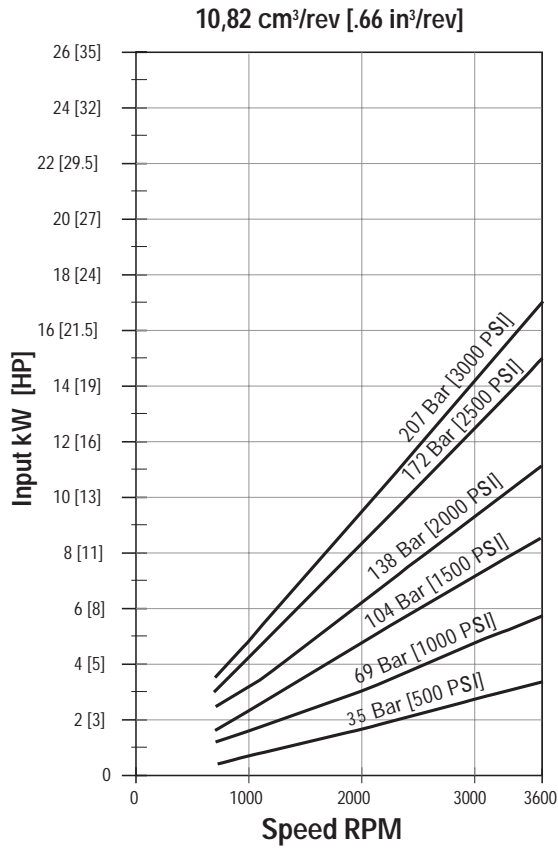

Series 26 Pump Performance Data

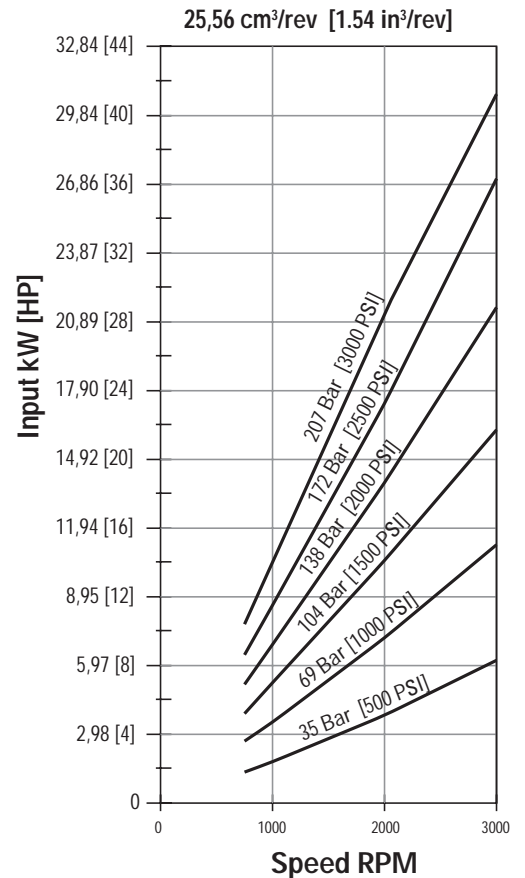
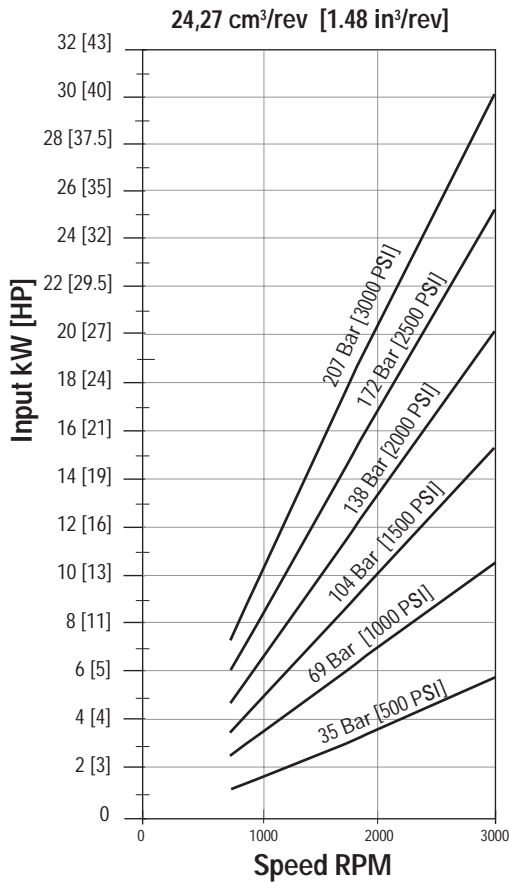
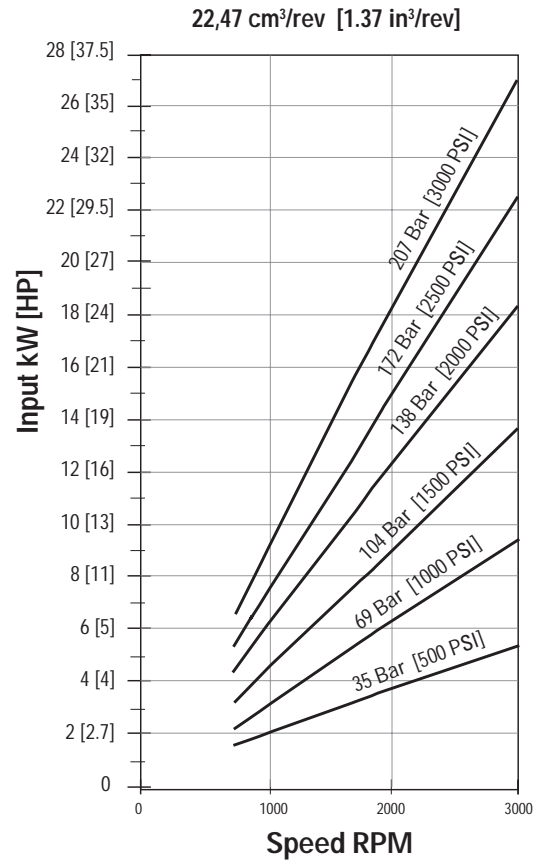
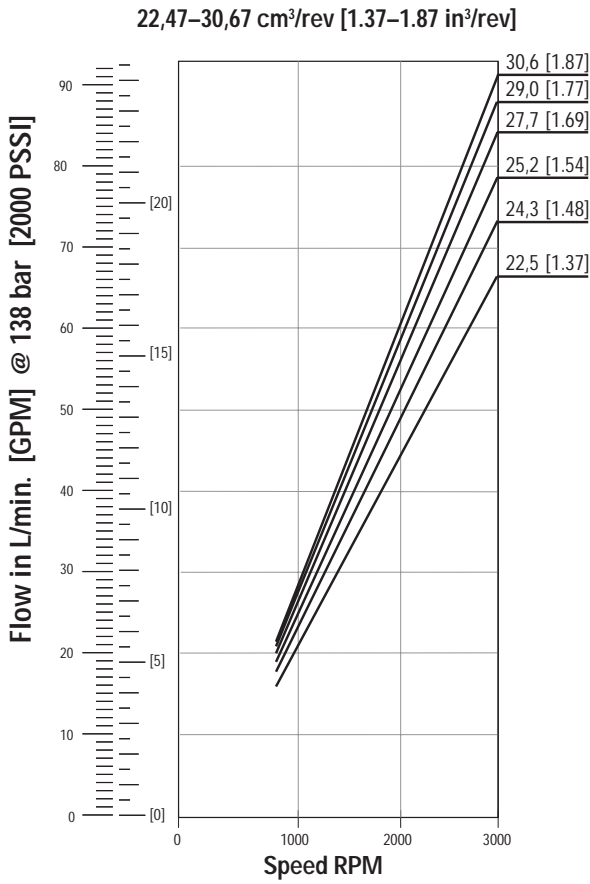

Series 26 Pump Performance Data

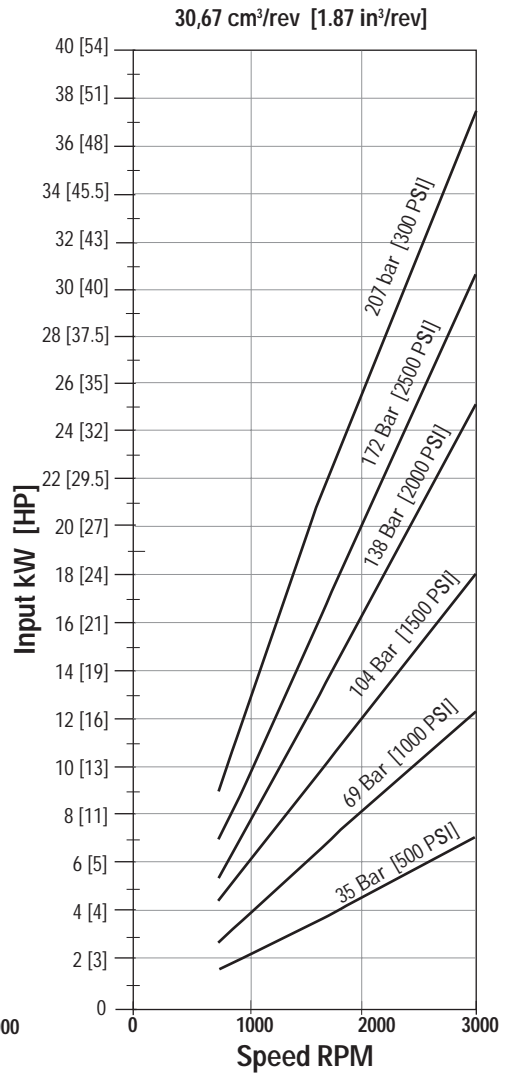
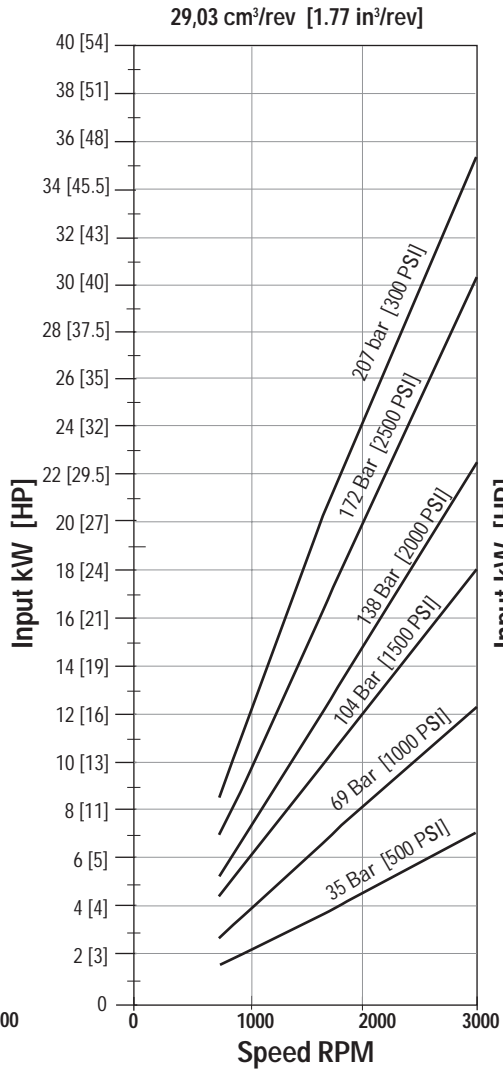
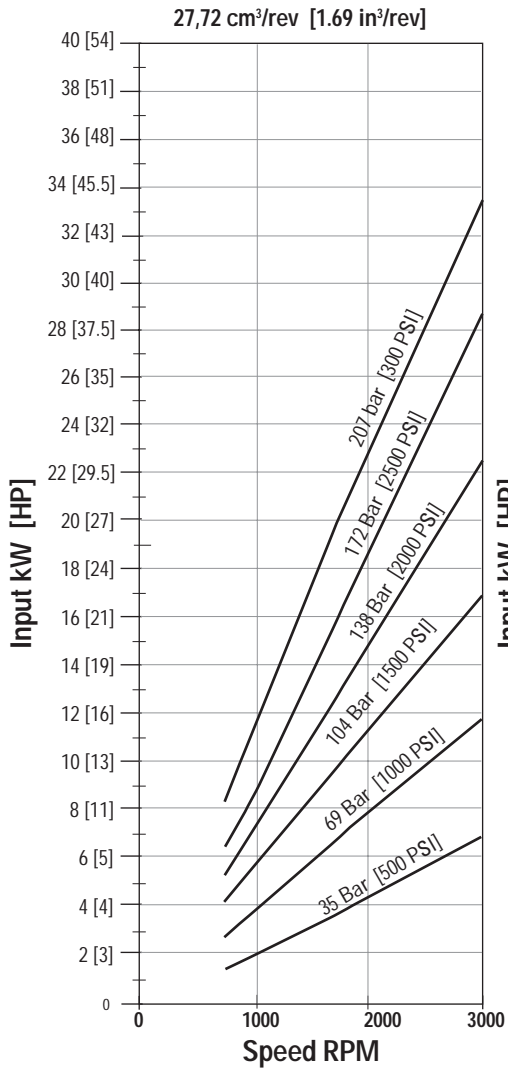

Series 26 Pump Standard Catalog Assemblies - Dimensions

All dimensions are in mm [in].

*** Multiple pump input torque limitations:**
the total torque for multiple pump displacements and pressure combinations cannot exceed the maximum input torque

rating of the shaft.
The proper formula is Pressure times Displacement divided by 6.28.

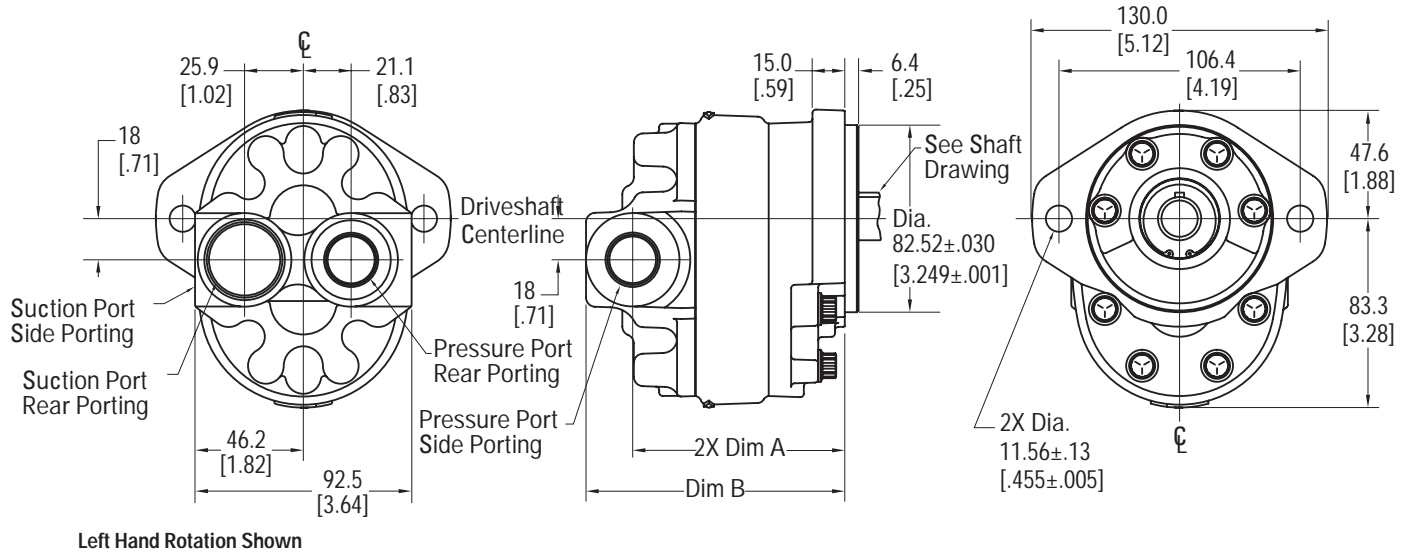

Model	26001	26002	26003	26004	26005	26006	26007
Displacement (cm ³ /r [in ³ /r])	6.6 [.40]	8.2 [.50]	9.5 [.58]	10.8 [.66]	13.8 [.84]	16.7 [1.02]	19.7 [1.20]
Dimension A (mm [in])	72.6 [2.86]	74.3 [2.93]	75.9 [2.99]	77.5 [3.05]	80.7 [3.18]	83.9 [3.30]	87.1 [3.43]
Dimension B (mm [in])	93.2 [3.67]	94.9 [3.74]	96.5 [3.80]	98.1 [3.86]	101.3 [3.99]	104.5 [4.11]	107.7 [4.24]

Model	26008	26009	26010	26011	26012	26013
Displacement (cm ³ /r [in ³ /r])	22.5 [1.37]	24.3 [1.48]	25.2 [1.54]	27.7 [1.69]	29.0 [1.77]	30.6 [1.87]
Dimension A (mm [in])	90.3 [3.56]	92.7 [3.65]	93.5 [3.68]	96.7 [3.81]	98.6 [3.88]	99.9 [3.93]
Dimension B (mm [in])	110.9 [4.37]	113.3 [4.46]	114.1 [4.49]	117.3 [4.62]	119.1 [4.69]	120.5 [4.74]

5/8 Inch 9 Tooth Spline
Maximum Input Torque
62 Nm [550 lb-in]

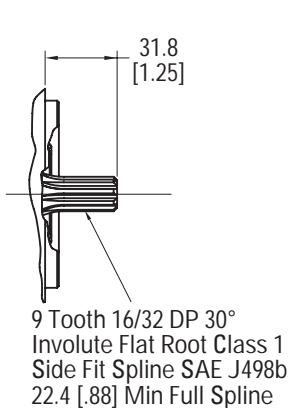

3/4 Inch 11 Tooth Spline
Maximum Input Torque
119 Nm [1050 lb-in]

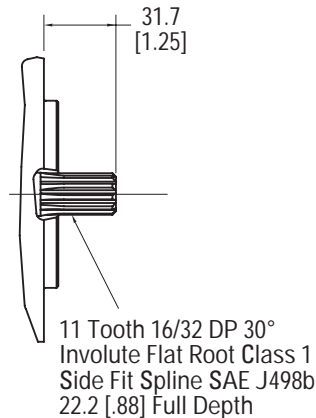

3/4 Inch Straight Key
Maximum Input Torque
113 Nm [1000 lb-in]

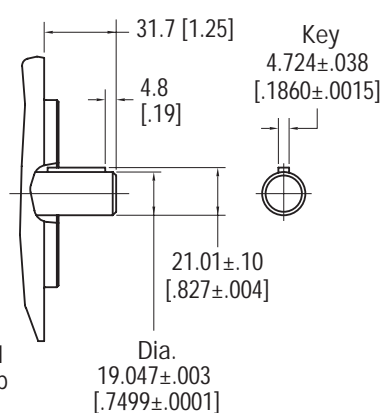

5/8 Inch Straight Key
Maximum Input Torque
56 Nm [500 lb-in]

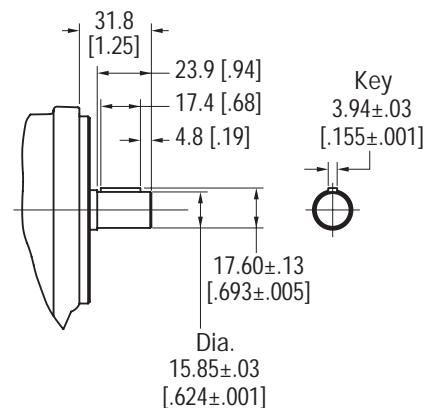

Series 26 Pump Order Numbers

* 5/8 9 T Spline has a maximum allowable input torque of 62 Nm [550 lb-in].

** 5/8 Keyed shaft has a maximum allowable input torque of 56 Nm [500 lb-in].

RIGHT HAND ROTATION PRODUCT NO	LEFT HAND ROTATION PRODUCT NO	SHAFT	PORT LOCATION	SAE O-RING PRESSURE PORT SIZE	SAE O-RING SUCTION PORT SIZE	REPLACES
Model 26001 – 6,6 cm³/r [40 in³/r] Displacement						
26001-RZG	26001-LZG	5/8 Keyed	Side	7/8-14 UNF-2B	1-1/16-12 UN-2B	24300-RZA/LZA
26001-RZH	26001-LZH	5/8 Keyed	Rear	7/8-14 UNF-2B	1-1/16-12 UN-2B	24300-RZC/LZD
26001-RZJ	26001-LZJ	5/8 9 T Spline	Side	7/8-14 UNF-2B	1-1/16-12 UN-2B	24300-RZB/LZA
26001-RZK	26001-LZK	5/8 9 T Spline	Rear	7/8-14 UNF-2B	1-1/16-12 UN-2B	24300-RZD/LZE
Model 26002 – 8,2 cm³/r [50 in³/r] Displacement						
26002-RZA	26002-LZA	3/4 11T Spline	Side	7/8-14 UNF-2B	1-5/16-12 UN-2B	25300-RSA/LSA
26002-RZB	26002-LZB	3/4 11T Spline	Rear	7/8-14 UNF-2B	1-5/16-12 UN-2B	25300-RSB/LSB
26002-RZC	26002-LZC	3/4 Keyed	Side	7/8-14 UNF-2B	1-5/16-12 UN-2B	25300-RSC/LSC
26002-RZD	26002-LZD	3/4 Keyed	Rear	7/8-14 UNF-2B	1-5/16-12 UN-2B	25300-RSD/LSD
26002-RZE	26002-LZE	5/8 9 T Spline	Side	7/8-14 UNF-2B	1-5/16-12 UN-2B	25300-RSE/LSE
26002-RZF	26002-LZF	5/8 9 T Spline	Rear	7/8-14 UNF-2B	1-5/16-12 UN-2B	25300-RSF/LSF
26002-RZG	26002-LZG	5/8 Keyed	Side	7/8-14 UNF-2B	1-1/16-12 UN-2B	24301-RZC/LZA
26002-RZH	26002-LZH	5/8 Keyed	Rear	7/8-14 UNF-2B	1-1/16-12 UN-2B	24301-RZG/LZG
26002-RZJ	26002-LZJ	5/8 9 T Spline	Side	7/8-14 UNF-2B	1-1/16-12 UN-2B	24301-RZD/LZB
26002-RZK	26002-LZK	5/8 9 T Spline	Rear	7/8-14 UNF-2B	1-1/16-12 UN-2B	24301-RZH/LZH
Model 26003 – 9,5 cm³/r [58 in³/r] Displacement						
26003-RZG	26003-LZG	5/8 Keyed	Side	7/8-14 UNF-2B	1-1/16-12 UN-2B	24302-RZB/LZB
26003-RZH	26003-LZH	5/8 Keyed	Rear	7/8-14 UNF-2B	1-1/16-12 UN-2B	24302-RZC/LZD
26003-RZJ	26003-LZJ	5/8 9 T Spline	Side	7/8-14 UNF-2B	1-1/16-12 UN-2B	24302-RZA/LZA
26003-RZK	26003-LZK	5/8 9 T Spline	Rear	7/8-14 UNF-2B	1-1/16-12 UN-2B	24302-RZD/LZE
Model 26004 – 10,8 cm³/r [66 in³/r] Displacement						
26004-RZA	26004-LZA	3/4 11T Spline	Side	7/8-14 UNF-2B	1-5/16-12 UN-2B	25301-RSA/LSA
26004-RZB	26004-LZB	3/4 11T Spline	Rear	7/8-14 UNF-2B	1-5/16-12 UN-2B	25301-RSB/LSB
26004-RZC	26004-LZC	3/4 Keyed	Side	7/8-14 UNF-2B	1-5/16-12 UN-2B	25301-RSC/LSC
26004-RZD	26004-LZD	3/4 Keyed	Rear	7/8-14 UNF-2B	1-5/16-12 UN-2B	25301-RSD/LSD
26004-RZE	26004-LZE	5/8 9 T Spline	Side	7/8-14 UNF-2B	1-5/16-12 UN-2B	25301-RSE/LSE
26004-RZF	26004-LZF	5/8 9 T Spline	Rear	7/8-14 UNF-2B	1-5/16-12 UN-2B	25301-RSF/LSF
26004-RZG	26004-LZG	5/8 Keyed	Side	7/8-14 UNF-2B	1-1/16-12 UN-2B	24303-RZB/LZB
26004-RZH	26004-LZH	5/8 Keyed	Rear	7/8-14 UNF-2B	1-1/16-12 UN-2B	24303-RZE/LZF
26004-RZJ	26004-LZJ	5/8 9 T Spline	Side	7/8-14 UNF-2B	1-1/16-12 UN-2B	24303-RZD/LZA
26004-RZK	26004-LZK	5/8 9 T Spline	Rear	7/8-14 UNF-2B	1-1/16-12 UN-2B	24303-RZF/LZG
Model 26005 – 13,8 cm³/r [84 in³/r] Displacement						
26005-RZA	26005-LZA	3/4 11T Spline	Side	7/8-14 UNF-2B	1-5/16-12 UN-2B	25302-RSA/LSA
26005-RZB	26005-LZB	3/4 11T Spline	Rear	7/8-14 UNF-2B	1-5/16-12 UN-2B	25302-RSB/LSB
26005-RZC	26005-LZC	3/4 Keyed	Side	7/8-14 UNF-2B	1-5/16-12 UN-2B	25302-RSC/LSC
26005-RZD	26005-LZD	3/4 Keyed	Rear	7/8-14 UNF-2B	1-5/16-12 UN-2B	25302-RSD/LSD
26005-RZE	26005-LZE	5/8 9 T Spline	Side	7/8-14 UNF-2B	1-5/16-12 UN-2B	25302-RSE/LSE
26005-RZF	26005-LZF	5/8 9 T Spline	Rear	7/8-14 UNF-2B	1-5/16-12 UN-2B	25302-RSF/LSF
26005-RZG	26005-LZG	5/8 Keyed	Side	7/8-14 UNF-2B	1-1/16-12 UN-2B	24304-RZC/LZA
26005-RZH	26005-LZH	5/8 Keyed	Rear	7/8-14 UNF-2B	1-1/16-12 UN-2B	24304-RZG/LZF
26005-RZJ	26005-LZJ	5/8 9 T Spline	Side	7/8-14 UNF-2B	1-1/16-12 UN-2B	24304-RZD/LZB
26005-RZK	26005-LZK	5/8 9 T Spline	Rear	7/8-14 UNF-2B	1-1/16-12 UN-2B	24304-RZH/LZG
Model 26006 – 16,7 cm³/r [1.02 in³/r] Displacement						
26006-RZA	26006-LZA	3/4 11T Spline	Side	7/8-14 UNF-2B	1-5/16-12 UN-2B	25303-RSA/LSA
26006-RZB	26006-LZB	3/4 11T Spline	Rear	7/8-14 UNF-2B	1-5/16-12 UN-2B	25303-RSB/LSB
26006-RZC	26006-LZC	3/4 Keyed	Side	7/8-14 UNF-2B	1-5/16-12 UN-2B	25303-RSC/LSC
26006-RZD	26006-LZD	3/4 Keyed	Rear	7/8-14 UNF-2B	1-5/16-12 UN-2B	25303-RSD/LSD
26006-RZE	26006-LZE	5/8 9 T Spline	Side	7/8-14 UNF-2B	1-5/16-12 UN-2B	25303-RSE/LSE
26006-RZF	26006-LZF	5/8 9 T Spline	Rear	7/8-14 UNF-2B	1-5/16-12 UN-2B	25303-RSF/LSF
26006-RZG	26006-LZG	5/8 Keyed	Side	7/8-14 UNF-2B	1-1/16-12 UN-2B	24305-RZC/LZA
26006-RZH	26006-LZH	5/8 Keyed	Rear	7/8-14 UNF-2B	1-1/16-12 UN-2B	24305-RZG/LZF
26006-RZJ	26006-LZJ	5/8 9 T Spline	Side	7/8-14 UNF-2B	1-1/16-12 UN-2B	24305-RZD/LZB
26006-RZK	26006-LZK	5/8 9 T Spline	Rear	7/8-14 UNF-2B	1-1/16-12 UN-2B	24305-RZH/LZG

Series 26 Pump Order Numbers

* 5/8 9 T Spline has a maximum allowable input torque of 62 Nm [550 lb-in].

** 5/8 Keyed shaft has a maximum allowable input torque of 56 Nm [500 lb-in].

RIGHT HAND ROTATION PRODUCT NO	LEFT HAND ROTATION PRODUCT NO	SHAFT	PORT LOCATION	SAE O-RING PRESSURE PORT SIZE	SAE O-RING SUCTION PORT SIZE	REPLACES
Model 26007 – 19,7 cm³/r [1.20 in³/r] Displacement						
26007-RZA	26007-LZA	3/4 11T Spline	Side	7/8-14 UNF-2B	1-5/16-12 UN-2B	25304-RSA/LSA
26007-RZB	26007-LZB	3/4 11T Spline	Rear	7/8-14 UNF-2B	1-5/16-12 UN-2B	25304-RSB/LSB
26007-RZC	26007-LZC	3/4 Keyed	Side	7/8-14 UNF-2B	1-5/16-12 UN-2B	25304-RSC/LSC
26007-RZD	26007-LZD	3/4 Keyed	Rear	7/8-14 UNF-2B	1-5/16-12 UN-2B	25304-RSD/LSD
26007-RZE	26007-LZE	*5/8 9 T Spline	Side	7/8-14 UNF-2B	1-5/16-12 UN-2B	25304-RSE/LSE
26007-RZF	26007-LZF	*5/8 9 T Spline	Rear	7/8-14 UNF-2B	1-5/16-12 UN-2B	25304-RSF/LSF
26007-RZG	26007-LZG	**5/8 Keyed	Side	7/8-14 UNF-2B	1-1/16-12 UN-2B	24306-RZA/LZA
26007-RZH	26007-LZH	**5/8 Keyed	Rear	7/8-14 UNF-2B	1-1/16-12 UN-2B	24306-RZE/LZF
26007-RZJ	26007-LZJ	*5/8 9 T Spline	Side	7/8-14 UNF-2B	1-1/16-12 UN-2B	24306-RZD/LZB
26007-RZK	26007-LZK	*5/8 9 T Spline	Rear	7/8-14 UNF-2B	1-1/16-12 UN-2B	24306-RZF/LZG
Model 26008 – 22,5 cm³/r [1.37 in³/r] Displacement						
26008-RZA	26008-LZA	3/4 11T Spline	Side	7/8-14 UNF-2B	1-5/16-12 UN-2B	25305-RSA/LSA
26008-RZB	26008-LZB	3/4 11T Spline	Rear	7/8-14 UNF-2B	1-5/16-12 UN-2B	25305-RSB/LSB
26008-RZC	26008-LZC	3/4 Keyed	Side	7/8-14 UNF-2B	1-5/16-12 UN-2B	25305-RSC/LSC
26008-RZD	26008-LZD	3/4 Keyed	Rear	7/8-14 UNF-2B	1-5/16-12 UN-2B	25305-RSD/LSD
26008-RZE	26008-LZE	*5/8 9 T Spline	Side	7/8-14 UNF-2B	1-5/16-12 UN-2B	25305-RSE/LSE
26008-RZF	26008-LZF	*5/8 9 T Spline	Rear	7/8-14 UNF-2B	1-5/16-12 UN-2B	25305-RSF/LSF
Model 26009 – 24,3 cm³/r [1.48 in³/r] Displacement						
26009-RZG	26009-LZG	**5/8 Keyed	Side	7/8-14 UNF-2B	1-1/16-12 UN-2B	24307-RZC/LZA
26009-RZH	26009-LZH	**5/8 Keyed	Rear	7/8-14 UNF-2B	1-1/16-12 UN-2B	24307-RZG/LZF
26009-RZJ	26009-LZJ	*5/8 9 T Spline	Side	7/8-14 UNF-2B	1-1/16-12 UN-2B	24307-RZD/LZB
26009-RZK	26009-LZK	*5/8 9 T Spline	Rear	7/8-14 UNF-2B	1-1/16-12 UN-2B	24307-RZH/LZG
Model 26010 – 25,2 cm³/r [1.54 in³/r] Displacement						
26010-RZA	26010-LZA	3/4 11T Spline	Side	7/8-14 UNF-2B	1-5/16-12 UN-2B	25306-RSA/LSA
26010-RZB	26010-LZB	3/4 11T Spline	Rear	7/8-14 UNF-2B	1-5/16-12 UN-2B	25306-RSB/LSB
26010-RZC	26010-LZC	3/4 Keyed	Side	7/8-14 UNF-2B	1-5/16-12 UN-2B	25306-RSC/LSC
26010-RZD	26010-LZD	3/4 Keyed	Rear	7/8-14 UNF-2B	1-5/16-12 UN-2B	25306-RSD/LSD
26010-RZE	26010-LZE	*5/8 9 T Spline	Side	7/8-14 UNF-2B	1-5/16-12 UN-2B	25306-RSE/LSE
26010-RZF	26010-LZF	*5/8 9 T Spline	Rear	7/8-14 UNF-2B	1-5/16-12 UN-2B	25306-RSF/LSF
Model 26011 – 27,7 cm³/r [1.69 in³/r] Displacement						
26011-RZA	26011-LZA	3/4 11T Spline	Side	7/8-14 UNF-2B	1-5/16-12 UN-2B	25307-RSA/LSA
26011-RZB	26011-LZB	3/4 11T Spline	Rear	7/8-14 UNF-2B	1-5/16-12 UN-2B	25307-RSB/LSB
26011-RZC	26011-LZC	3/4 Keyed	Side	7/8-14 UNF-2B	1-5/16-12 UN-2B	25307-RSC/LSC
26011-RZD	26011-LZD	3/4 Keyed	Rear	7/8-14 UNF-2B	1-5/16-12 UN-2B	25307-RSD/LSD
26011-RZE	26011-LZE	*5/8 9 T Spline	Side	7/8-14 UNF-2B	1-5/16-12 UN-2B	25307-RSE/LSE
26011-RZF	26011-LZF	*5/8 9 T Spline	Rear	7/8-14 UNF-2B	1-5/16-12 UN-2B	25307-RSF/LSF
Model 26012 – 29,0 cm³/r [1.77 in³/r] Displacement						
26012-RZG	26012-LZG	**5/8 Keyed	Side	7/8-14 UNF-2B	1-1/16-12 UN-2B	24308-RZA/LZA
26012-RZH	26012-LZH	**5/8 Keyed	Rear	7/8-14 UNF-2B	1-1/16-12 UN-2B	24308-RZE/LZF
26012-RZJ	26012-LZJ	*5/8 9 T Spline	Side	7/8-14 UNF-2B	1-1/16-12 UN-2B	24308-RZD/LZB
26012-RZK	26012-LZK	*5/8 9 T Spline	Rear	7/8-14 UNF-2B	1-1/16-12 UN-2B	24308-RZF/LZG
Model 26013 – 30,6 cm³/r [1.87 in³/r] Displacement						
26013-RZA	26013-LZA	3/4 11T Spline	Side	7/8-14 UNF-2B	1-5/16-12 UN-2B	25308-RZA/LZA
26013-RZB	26013-LZB	3/4 11T Spline	Rear	7/8-14 UNF-2B	1-5/16-12 UN-2B	25308-RZB/LZB
26013-RZC	26013-LZC	3/4 Keyed	Side	7/8-14 UNF-2B	1-5/16-12 UN-2B	25308-RZC/LZC
26013-RZD	26013-LZD	3/4 Keyed	Rear	7/8-14 UNF-2B	1-5/16-12 UN-2B	25308-RZD/LZD
26013-RZE	26013-LZE	*5/8 9 T Spline	Side	7/8-14 UNF-2B	1-5/16-12 UN-2B	25308-RZE/LZE
26013-RZF	26013-LZF	*5/8 9 T Spline	Rear	7/8-14 UNF-2B	1-5/16-12 UN-2B	25308-RZF/LZF

Series 26 Pump

Optional Configurations

The Series 26 Gear Pump components can be assembled into many optional configurations. The versatile design allows you to assemble a pump to meet your specific needs.

Model codes for single and multiple pumps along with the component part dimension drawings are given on the following pages.

Single Gear Pump with Tandem Backplate

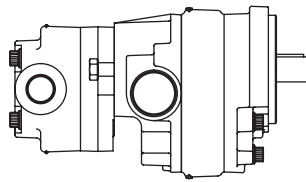

Double Gear Pump with Tandem Backplate

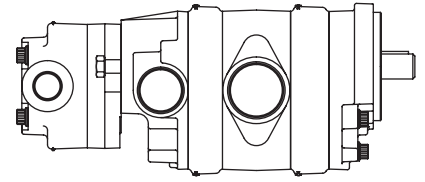

Triple Gear Pump with Two Suction Ports and Tandem Backplate

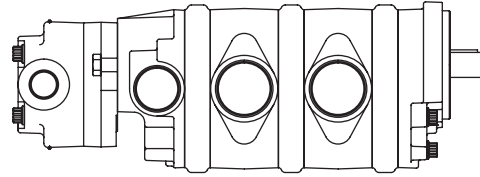

Single Gear Pump

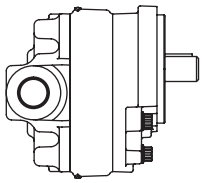

Double Gear Pump with Common Suction Port

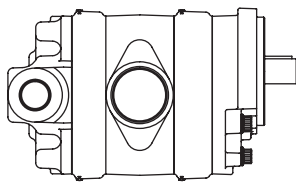

Single Gear Pump w/Tandem Flow Divider Backplate

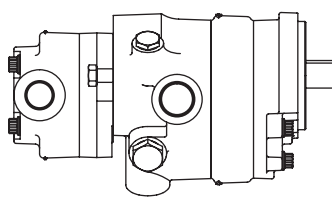

Double Gear Pump with Tandem Flow Divider Backplate

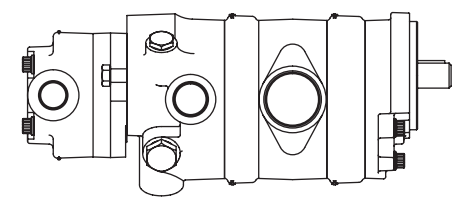

Triple Gear Pump with Two Suction Ports

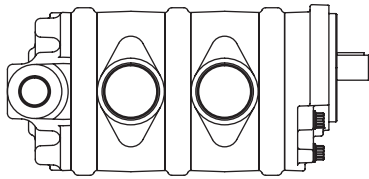

Triple Gear Pump with Two Suction Ports and Tandem Flow Divider Backplate

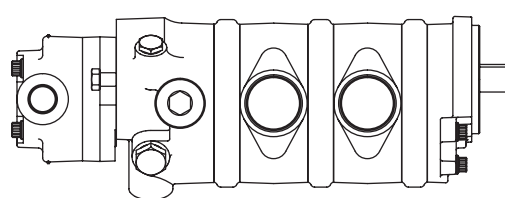

Single Gear Pump with Relief Valve

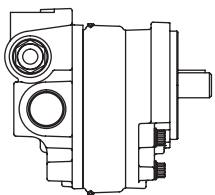

Double Gear Pump with Relief Valve

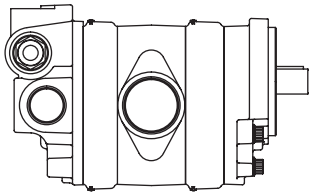

Single Gear Pump with Flow Divider and Relief Valve

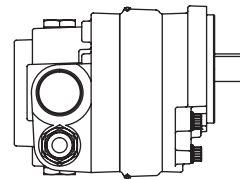

Double Gear Pump with Flow Divider and Relief Valve

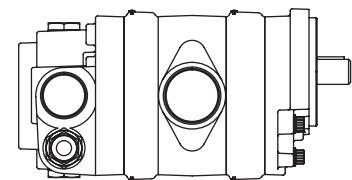

Triple Gear Pump with Two Suction Ports and Relief Valve

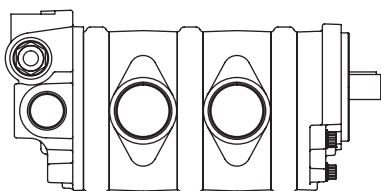

Triple Gear Pump with Two Suction Ports, Flow Divider and Relief Valve

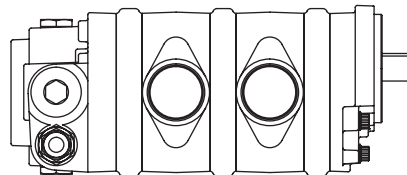

Series 26 Pump Component Parts - Dimensions

All dimensions are in mm [in].

Front Plate

SAE A 2 Bolt Flange Used
on all Standard Catalog
Assemblies

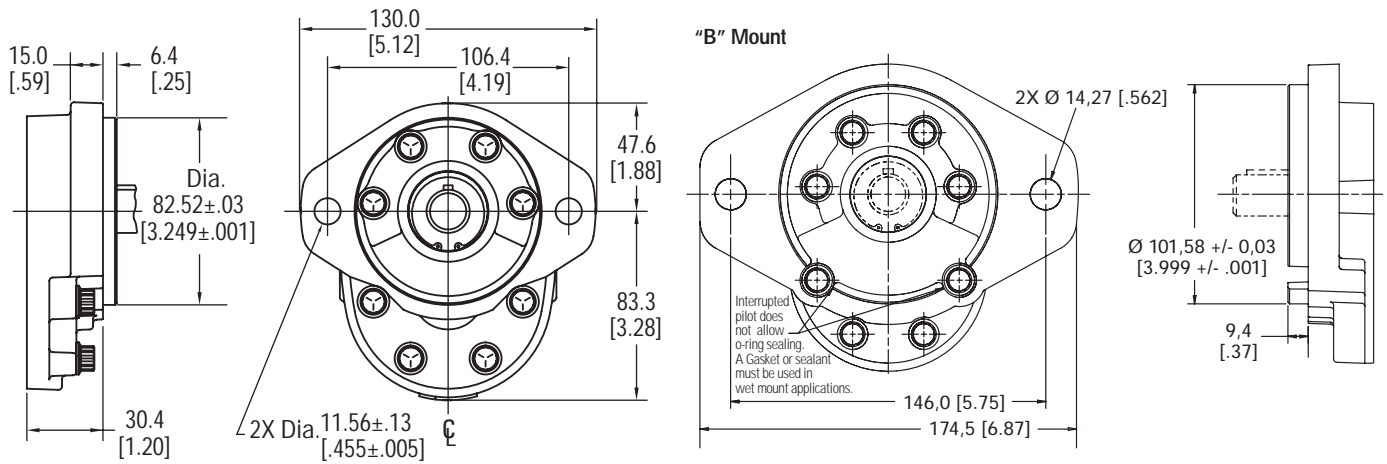

4 Bolt Euro Mount

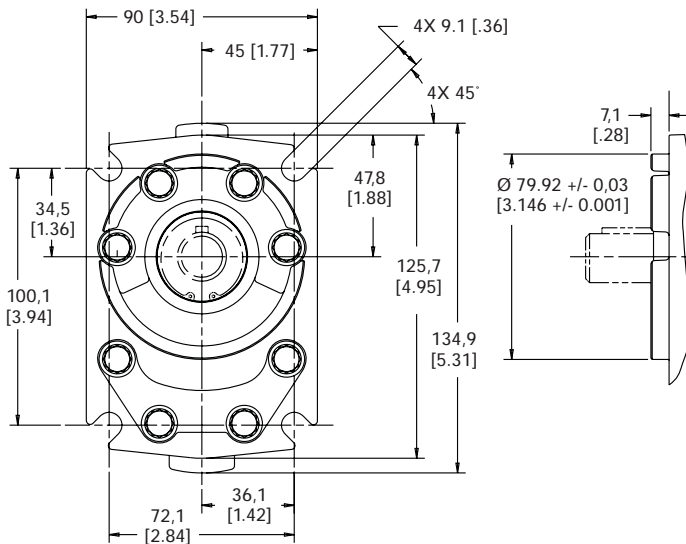

Body

Used on Single and
Multiple Pumps

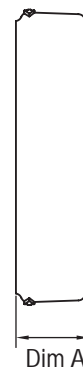

Model	26001	26002	26003	26004	26005	26006	26007
Displacement (cm ³ /r [in ³ /r])	6.6 [.40]	8.2 [.50]	9.5 [.58]	10.8 [.66]	13.8 [.84]	16.7 [1.02]	19.7 [1.20]
Dimension A (mm [in])	14.4 [.57]	16.3 [.64]	17.7 [.70]	19.5 [.77]	22.7 [.89]	25.9 [1.02]	29.1 [1.15]

Model	26008	26009	26010	26011	26012	26013
Displacement (cm ³ /r [in ³ /r])	22.5 [1.37]	24.3 [1.48]	25.2 [1.54]	27.7 [1.69]	29.0 [1.77]	30.6 [1.87]
Dimension A (mm [in])	32.3 [1.27]	34.7 [1.36]	35.5 [1.40]	38.7 [1.52]	40.3 [1.59]	41.9 [1.65]

Series 26 Pump Component Parts - Dimensions

All dimensions are in mm [in].

Backplate

Used on Single and
Multiple Pumps

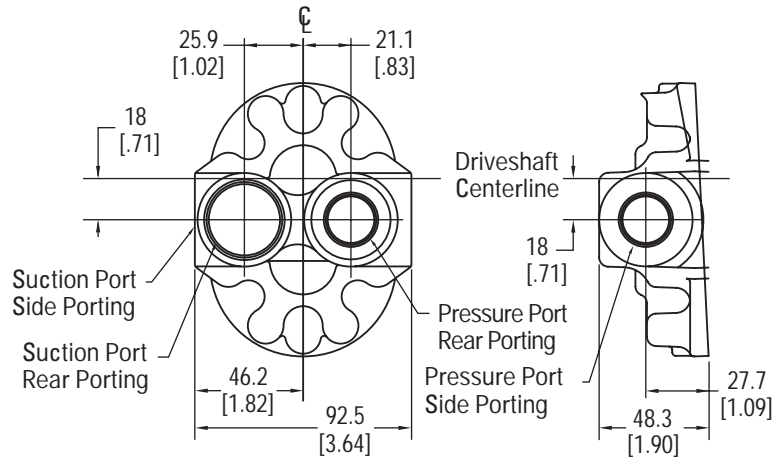

Left Hand Rotation Shown

Flow Divider Backplate

Used on Single and
Multiple Pumps

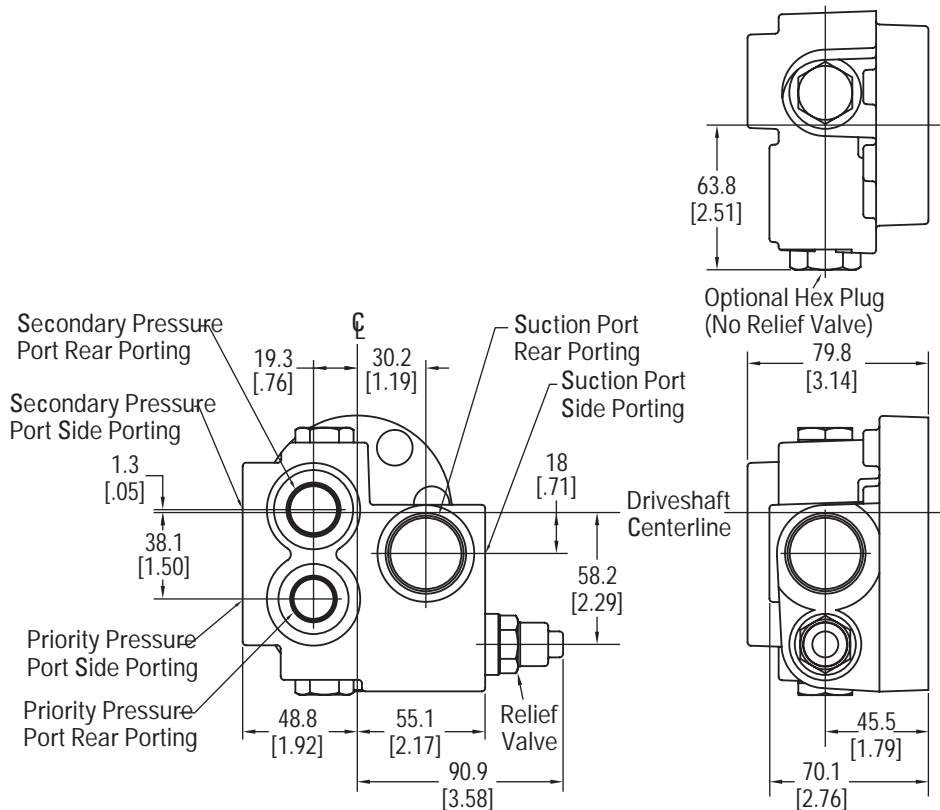

Right Hand Rotation Shown

Series 26 Pump Component Parts - Dimensions

All dimensions are in mm [in].

Relief Valve Backplate

Used on Single and Multiple Pumps - Right Hand Rotation Shown

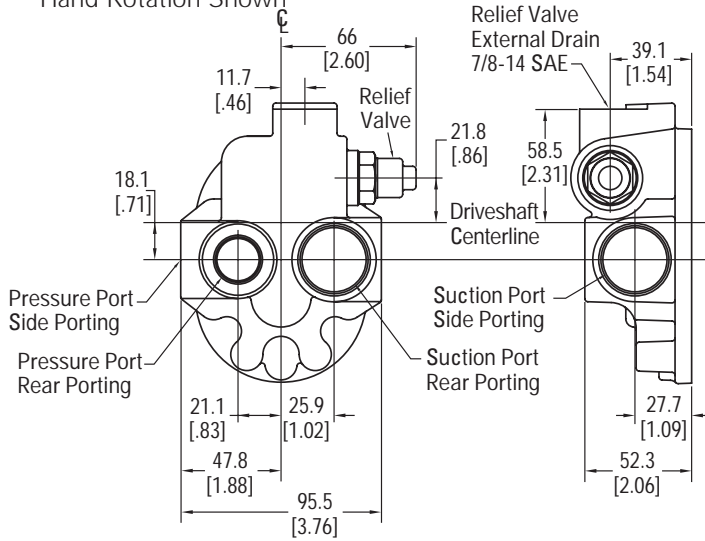

Adaptor Plate

Used on Multiple Pumps - Right Hand Rotation Shown

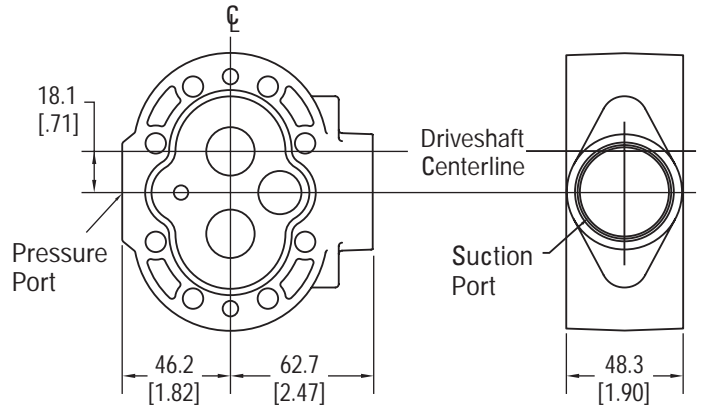

Tandem Backplate

Used on Single and Multiple Pumps
SAE AA 2 Bolt Flange

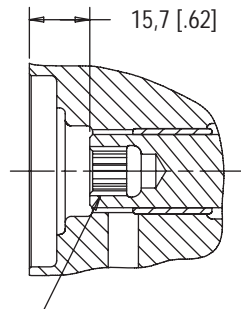

9 tooth 20/40 DP 30°
invlt flat root class I
side fit spline SAE J498b
9.7 [.38] min. full spline

Max Torque Rating: 29.5 Nm [261 lbf·in]

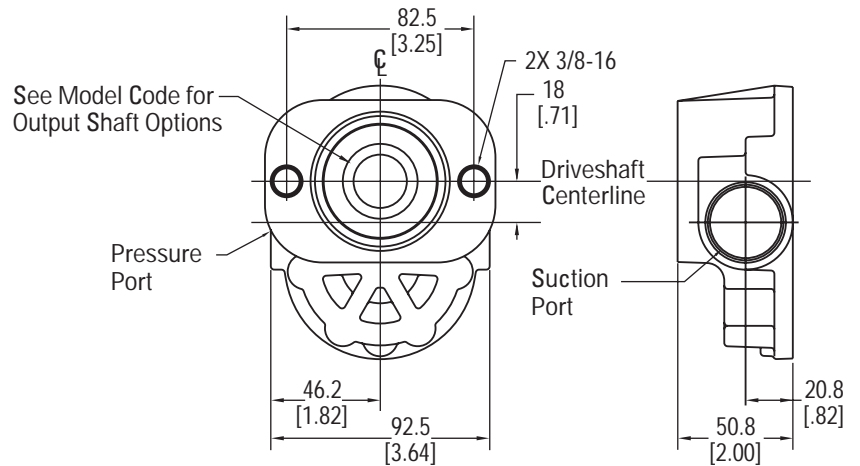

Right Hand Rotation Shown

Series 26 Pump Model Code - Single

Series 26 Gear Pumps can be ordered by using the following Model Code.

A twenty-four digit coding system has been designed to identify the features presently available on single gear pumps. The characters and their relative positions

within the code identify specific features.

Use the Model Code Matrix as an aid when assembling the model code for the pump with the features you desire. It may be helpful to photocopy the matrix and

write the numbers and letters into the boxes as you select features.

All twenty-four digits of the code must be submitted when ordering.

All dimensions are in inches.

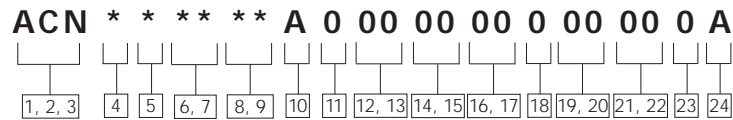

1, 2, 3 26 Series

ACN – Gear Pump - Single Unit

4 Unit Type

- A** – Plain
- B** – Flow Divider with/without Relief Valve (Pos. 14-15)
- C** – Relief Valve (Pos. 16-17)

5 Input Rotation (viewed from input shaft end)

- L** – Left-hand Rotation CCW
- R** – Right-hand Rotation CW

6, 7 Displacement (cm³/r [in³/r])

- 01** = 6.6 [.40]
- 02** = 8.2 [.50]
- 03** = 9.5 [.58]
- 04** = 10.8 [.66]
- 05** = 13.8 [.84]
- 06** = 16.7 [1.02]
- 07** = 19.7 [1.20]
- 08** = 22.5 [1.37]
- 09** = 24.3 [1.48]
- 10** = 25.2 [1.54]
- 11** = 27.7 [1.69]
- 12** = 29.0 [1.77]
- 13** = 30.6 [1.87]

8, 9 Input Shaft

AA = 5/8 Inch Dia. 9 Tooth Spline 16/32 Pitch Shaft Extension 31.8 [1.25]

AB = 3/4 Inch Dia. 11 Tooth Spline 16/32 Pitch Shaft Extension 31.8 [1.25]

AC = 3/4 Inch Dia. Straight Keyed, Keyway 4.8 x 25.4 [.19 x 1.00] Shaft Extension 31.8 [1.25]

AD = 5/8 Inch Dia. Straight Keyed, Keyway 4.1 X 18.3 [.16 X .72] Shaft Extension 31.8 [1.25]

10 Mounting Features

A = SAE 2-Bolt A Flange, Series 82-2

B = SAE 2-Bolt B Flange, Series 101-2

D = European 4-Bolt

11 Auxiliary Mounting Features

- 0** - No Rear Mounting
- C** - (2-Bolt AA) SAE Flange Series 50-2, with 9 Tooth Internal Spline 20/40 Pitch, Accepts 25.4 [1.00] Shaft Extension

12, 13 Ports, Sizes and Location- Backplate

01 = Plain: Suction Port 1.3125-12 UN-2B SAE O-ring Port; Pressure Port .875-14 UNF-2B SAE O-ring Port - Side Ports

02 = Plain: Suction Port 1.3125-12 UN-2B SAE O-ring Port; Pressure Port .875-14 UNF-2B SAE O-ring Port - Rear Ports

03 = Plain: Suction Port 1.0625-12 UN-2B SAE O-ring Port; Pressure Port .875-14 UNF-2B SAE O-ring Port Accepts Fittings Per SAE J1926 - Side Ports

04 = Plain: Suction Port 1.0625-12 UN-2B SAE O-ring Port; Pressure Port .875-14 UNF-2B SAE O-ring Port Accepts Fittings Per SAE J1926 -Rear Ports

08 = Plain Thru Shaft: Suction Port 1.0625-12 UN-2B SAE O-ring Port; Pressure Port .875-14 UNF-2B SAE O-ring Port - Side Ports

15 = Relief Valve: Suction Port 1.0625-12 UN-2B SAE O-ring Port; Pressure Port .875-14 UNF-2B SAE O-ring Port - Side Ports; Drain Port .875-14 UNF-2B SAE O-ring Port

16 = Relief Valve: Suction Port 1.0625-12 UN-2B SAE O-ring Port; Pressure Port .875-14 UNF-2B SAE O-ring Port - Rear Ports; Drain Port .875-14 UNF-2B SAE O-ring Port

20 = Flow Divider: Suction Port 1.3125-12 UN-2B SAE O-ring Port; Priority Pressure Port .750-16 UNF-2B SAE O-ring Port; Secondary Pressure Port .875-14 UNF-2B SAE O-ring Port - Side Ports

21 = Flow Divider: Suction Port 1.3125-12 UN-2B SAE O-ring Port; Priority Pressure Port .750-16 UNF-2B SAE O-ring Port; Secondary Pressure Port .875-14 UNF-2B SAE O-ring Port - Rear Ports

14, 15 Priority Flow Divider Setting (LPM [GPM])

- 00** = No Flow Setting
- AA** = 3.8 [1.00]
- AD** = 7.6 [2.00]
- AJ** = 11.4 [3.00]
- AL** = 15.1 [4.00]
- AN** = 18.9 [5.00]
- AR** = 22.7 [6.00]
- AS** = 26.5 [7.00]
- AT** = 30.3 [8.00]

16, 17 Relief Valve Full Flow Setting (bar [PSI])

- 00** = No Relief Valve Setting
- AA** = 34.5 [500]
- AB** = 51.7 [750]
- AC** = 68.9 [1000]
- AE** = 86.2 [1250]
- AF** = 103.4 [1500]
- AJ** = 120.7 [1750]
- AL** = 137.9 [2000]
- AN** = 155.1 [2250]
- AP** = 172.4 [2500]
- AR** = 189.6 [2750]
- AS** = 206.8 [3000]
- BR** = 241.3 [3500]
- BT** = 224.1 [3250]

18 Test Data

- 0** - Generic
- A** - Unit Specific (required for flow divider and relief valve options.)

19, 20 Special Features

- 00** - No Special Features
- AB** - Viton Shaft Seal

21, 22 Paint

- 00** - None
- 0A** - Red Primer
- 0B** - Black

23 Identification

- 0** - Standard

24 Design Code

- A** - A

Series 26 Pump Model Code - Multiple

Series 26 Gear Pumps can be ordered by using the following Model Code.

A thirty-two digit coding system has been designed to identify the features presently available on Multiple gear pumps.

The characters and their relative positions within the code identify specific features.

Use the Model Code Matrix as an aid when assembling the model code for the pump with the features you

desire. It may be helpful to photocopy the matrix and write the numbers and letters into the boxes as you select features.

All thirty-two digits of the code must be submitted when ordering.

All dimensions are in inches.

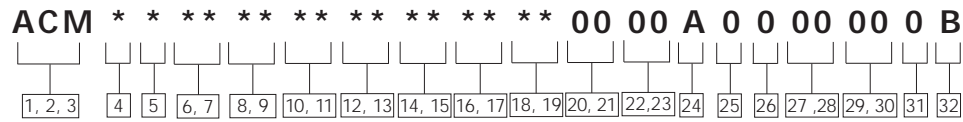

1, 2, 3 26 Series

ACM – Gear Pump - Multiple Unit

4 Unit Type

- A** – Plain
- B** – Flow Divider with/without Relief Valve (Pos. 20-21)
- C** – Relief Valve

5 Input Rotation (viewed from input shaft end)

- L** – Left-hand Rotation CCW
- R** – Right-hand Rotation CW

6, 7 Displacement - Front (cm³/r [in³/r])

- 01** = 6.6 [.40]
- 02** = 8.2 [.50]
- 03** = 9.5 [.58]
- 04** = 10.8 [.66]
- 05** = 13.8 [.84]
- 06** = 16.7 [1.02]
- 07** = 19.7 [1.20]
- 08** = 22.5 [1.37]
- 09** = 24.3 [1.48]
- 10** = 25.2 [1.54]
- 11** = 27.7 [1.69]
- 12** = 29.0 [1.77]
- 13** = 30.6 [1.87]

8, 9 Displacement - Ctr. Triple Only (cm³/r [in³/r])

- 01** = 6.6 [.40]
- 02** = 8.2 [.50]
- 03** = 9.5 [.58]
- 04** = 10.8 [.66]
- 05** = 13.8 [.84]
- 06** = 16.7 [1.02]
- 07** = 19.7 [1.20]
- 08** = 22.5 [1.37]
- 09** = 24.3 [1.48]
- 10** = 25.2 [1.54]
- 11** = 27.7 [1.69]
- 12** = 29.0 [1.77]
- 13** = 30.6 [1.87]
- 99** = No Center Displacement

10, 11 Displacement - Rear (cm³/r [in³/r])

- 01** = 6.6 [.40]
- 02** = 8.2 [.50]
- 03** = 9.5 [.58]
- 04** = 10.8 [.66]
- 05** = 13.8 [.84]
- 06** = 16.7 [1.02]
- 07** = 19.7 [1.20]
- 08** = 22.5 [1.37]
- 09** = 24.3 [1.48]
- 10** = 25.2 [1.54]
- 11** = 27.7 [1.69]
- 12** = 29.0 [1.77]
- 13** = 30.6 [1.87]

12, 13 Input Shaft

- AA** = 5/8 Inch Dia. 9 Tooth Spline 16/32 Pitch Shaft Extension 31.8 [1.25]
- AB** = 3/4 Inch Dia. 11 Tooth Spline 16/32 Pitch Shaft Extension 31.8 [1.25]
- AC** = 3/4 Inch Dia. Straight Keyed, Keyway 4.8 x 25.4 [.19 x 1.00] Shaft Extension 31.8 [1.25]
- AD** = 5/8 Inch Dia. Straight Keyed, Keyway 4.1 X 18.3 [.16 X .72] Shaft Extension 31.8 [1.25]

14, 15 Front Adapter Ports

- 01** = Suction Port 1-5/8–12 UN-2B SAE O-ring Port; Pressure Port 7/8–14 UNF-2B SAE O-ring Port
- 05** = Suction Port 1-5/16–12 UN-2B SAE O-ring Port; Pressure Port 7/8–14 UNF-2B SAE O-ring Port

16, 17 Ports - Rear Adapter (Triple Units)

- 00** = No Rear Adaptor
- 01** = Suction Port 1-5/8–12 UN-2B SAE O-ring Port; Pressure Port 7/8–14 UNF-2B SAE O-ring Port
- 05** = Suction Port 1-5/16–12 UN-2B SAE O-ring Port; Pressure Port 7/8–14 UNF-2B SAE O-ring Port

18, 19 Ports, Sizes and Location- Backplate

- 01 = Plain:** Suction Port 1-5/16–12 UN-2B SAE O-ring Port Size; Pressure Port 7/8–14 UNF-2B SAE O-ring Port–Side Ports
- 02 = Plain:** Suction Port 1-5/16–12 UN-2B SAE O-ring Port Size; Pressure Port 7/8–14 UNF-2B SAE O-ring Port–Rear Ports
- 03 = Plain:** Suction Port 1-1/16–12 UN-2B SAE O-ring Port Size; Pressure Port 7/8–14 UNF-2B SAE O-ring Port–Side Ports
- 04 = Plain:** Suction Port 1-1/16–12 UN-2B SAE O-ring Port Size; Pressure Port 7/8–14 UNF-2B SAE O-ring Port–Rear Ports
- 08 = Plain Tandem:** Suction Port 1.0625-12 UN-2B SAE O-ring Port; Pressure Port .875-14 UNF-2B SAE O-ring Port - Side Ports
- 14 = Plain:** Suction Port 1-5/16–12 UN-2B SAE O-ring Port Size–(Plugged); Pressure Port 7/8–14 UNF-2B SAE O-ring Port–Side Ports, used with position 14 and 15–01 and 16 and 17–10
- 17 = Plain:** Suction Port 1-5/16–12 UN-2B SAE O-ring Port Size–(Plugged); Pressure Port 7/8–14 UNF-2B SAE O-ring Port–Rear Ports, used with position 14 and 15–01 and 16 and 17–01
- 18 = Plain Tandem:** Suction Port 1.0625-12 UN-2B SAE O-ring Port (Plugged); Pressure Port .875-14 UNF-2B SAE O-ring Port - Side Ports

Series 26 Pump

Model Code - Multiple

All dimensions are in inches.

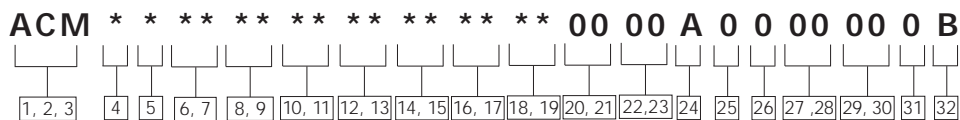

19 = Plain: Suction Port 1.3125-12 UN-2B SAE O-ring Port (Plugged); Pressure Port 1.0625-12 UN-2B SAE O-ring Port - Side Ports

20 = Relief Valve: Suction Port 1.0625-12 UN-2B SAE O-ring Port; Pressure Port .875-14 UNF-2B SAE O-ring Port - SIDE Ports; DRAIN Port .875-14 UNF-2B SAE O-ring Port

21 = Relief Valve: Suction Port 1.0625-12 UN-2B SAE O-ring Port; Pressure Port .875-14 UNF-2B SAE O-ring Port - Rear Ports; DRAIN Port .875-14 UNF-2B SAE O-ring Port - TOP Port

27 = Flow Divider: Suction Port 1.3125-12 UN-2B SAE O-ring Port; Priority Pressure Port .750-16 UNF-2B SAE O-ring Port; Secondary Pressure Port .875-14 UNF-2B SAE O-ring Port - SIDE Ports

28 = Flow Divider: Suction Port 1.3125-12 UN-2B SAE O-ring Port; Priority Pressure Port .750-16 UNF-2B SAE O-ring Port; Secondary Pressure Port .875-14 UNF-2B SAE O-ring Port - Rear Ports

29 = Flow Divider: Suction Port 1.0625-12 UN-2B SAE O-ring Port; Priority Pressure Port .5625-18 UNF-2B SAE O-ring Port; Secondary Pressure Port .875-14 UNF-2B SAE O-ring Port - SIDE Ports

Consult your Eaton representative when requiring common inlet option.

20, 21 Priority Flow Divider Setting (LPM [GPM])

00 = No Flow Setting

AA = 3.8 [1.00]

AD = 7.6 [2.00]

AJ = 11.4 [3.00]

AL = 15.1 [4.00]

AN = 18.9 [5.00]

AR = 22.7 [6.00]

AS = 26.5 [7.00]

AT = 30.3 [8.00]

22, 23 Relief Valve Full Flow Setting (bar [PSI])

00 = No Relief Valve Setting

AA = 34.5 [500]

AB = 51.7 [750]

AC = 68.9 [1000]

AE = 86.2 [1250]

AF = 103.4 [1500]

AJ = 120.7 [1750]

AL = 137.9 [2000]

AN = 155.1 [2250]

AP = 172.4 [2500]

AR = 189.6 [2750]

AS = 206.8 [3000]

24 Mounting Features (Front)

A = (2-Bolt A) SAE Flange, Series 82-3

C = (2-Bolt B) SAE Flange Series 82.3

G = (4-Bolt) European

25 Auxiliary Mounting Features

0 = No Rear Mounting

C = (2-Bolt AA) SAE Flange Series 50-2, with 9 Tooth Internal Spline 20/40 Pitch, Accepts 25.4 [1.00] Shaft Extension

26 Test Data

0 - Generic

A - Unit Specific (required for flow divider and relief valve options.)

27, 28 Special Features

00 - No Special Features

AB - Viton Shaft Seal

29, 30 Paint

00 - None

0A - Red Primer

0B - Black

31 Identification

0 - Standard

32 Design Code

B - B

Series 26 Pump Side-Load Application

Maximum Allowable Operating Pressures

Ideal positions shown. Side load is acceptable within 90° of either side of the ideal position. Charts are based on 100% slack side tension. Max. speed per catalog. Max. operating pressure shown.

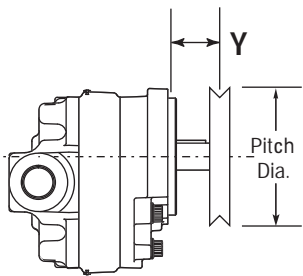

Gear Drive

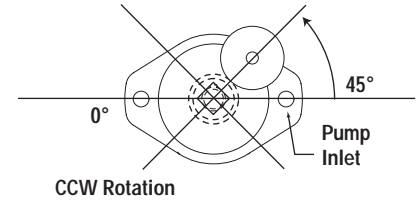
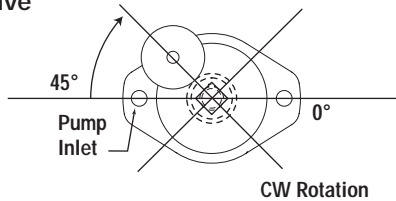

Pulley Drive

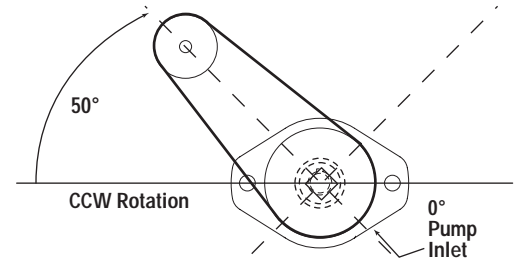
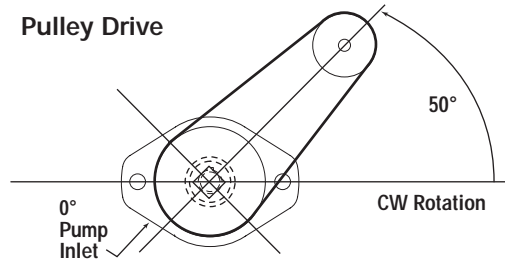

0.40/0.50 CID

PULLEY Φ	2	4	6	8	10	12
GEAR PITCH Φ	1	2	3	4	5	6
Y Dimension						
2.0"	3000	3000	3000	3000	3000	3000
1.5"	3000	3000	3000	3000	3000	3000
1.0"	3000	3000	3000	3000	3000	3000
0.5"	3000	3000	3000	3000	3000	3000
0"	3000	3000	3000	3000	3000	3000

0.58/0.66 CID

PULLEY Φ	2	4	6	8	10	12
GEAR PITCH Φ	1	2	3	4	5	6
Y Dimension						
2.0"	2250	3000	3000	3000	3000	3000
1.5"	2250	3000	3000	3000	3000	3000
1.0"	2500	3000	3000	3000	3000	3000
0.5"	2500	3000	3000	3000	3000	3000
0"	2750	3000	3000	3000	3000	3000

.84 CID

PULLEY Φ	2	4	6	8	10	12
GEAR PITCH Φ	1	2	3	4	5	6
Y Dimension						
2.0"	1750	2500	3000	3000	3000	3000
1.5"	1750	2750	3000	3000	3000	3000
1.0"	2000	2750	3000	3000	3000	3000
0.5"	2000	3000	3000	3000	3000	3000
0"	2250	3000	3000	3000	3000	3000

1.02 CID

PULLEY Φ	2	4	6	8	10	12
GEAR PITCH Φ	1	2	3	4	5	6
Y Dimension						
2.0"	1250	2000	2250	2500	2750	3000
1.5"	1250	2000	2500	2750	3000	3000
1.0"	1250	2000	2500	2750	3000	3000
0.5"	1500	2250	2500	2750	3000	3000
0"	1500	2250	2750	3000	3000	3000

Series 26 Pump

Side-Load Application

Maximum Allowable Operating Pressures

Ideal positions shown. Side load is acceptable within 90° of either side of the ideal position. Charts are based on 100% slack side tension. Max. speed per catalog. Max. operating pressure shown.

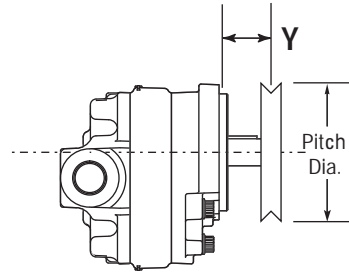

1.20 CID

PULLEY Φ	2	4	6	8	10	12
GEAR PITCH Φ	1	2	3	4	5	6
Y Dimension						
2.0"	N/R	1500	2000	2250	2250	2500
1.5"	N/R	1500	2000	2250	2500	2500
1.0"	N/R	1750	2000	2250	2500	2500
0.5"	1250	1750	2250	2250	2500	2750
0"	1250	1750	2250	2500	2750	3000

1.69 CID

PULLEY Φ	2	4	6	8	10	12
GEAR PITCH Φ	1	2	3	4	5	6
Y Dimension						
2.0"	N/R	N/R	1250	1500	1500	1750
1.5"	N/R	N/R	1250	1500	1500	1750
1.0"	N/R	N/R	1250	1500	1750	1750
0.5"	N/R	1250	1250	1500	1750	1750
0"	N/R	1250	1500	1750	1750	2000

1.37 CID

PULLEY Φ	2	4	6	8	10	12
GEAR PITCH Φ	1	2	3	4	5	6
Y Dimension						
2.0"	N/R	1250	1750	2000	2000	2250
1.5"	N/R	1250	1750	2000	2000	2250
1.0"	N/R	1500	1750	2000	2250	2250
0.5"	N/R	1500	1750	2000	2250	2250
0"	N/R	1500	1750	2000	2250	2500

1.77/1.87 CID

PULLEY Φ	2	4	6	8	10	12
GEAR PITCH Φ	1	2	3	4	5	6
Y Dimension						
2.0"	N/R	N/R	N/R	1250	1500	1500
1.5"	N/R	N/R	1250	1250	1500	1500
1.0"	N/R	N/R	1250	1250	1500	1500
0.5"	N/R	N/R	1250	1500	1500	1750
0"	N/R	N/R	1250	1500	1750	1750

1.48/1.54 CID

PULLEY Φ	2	4	6	8	10	12
GEAR PITCH Φ	1	2	3	4	5	6
Y Dimension						
2.0"	N/R	N/R	1250	1500	1750	2000
1.5"	N/R	1250	1500	1750	1750	2000
1.0"	N/R	1250	1500	1750	2000	2000
0.5"	N/R	1250	1500	1750	2000	2000
0"	N/R	1500	1750	2000	2000	2250

Series 26 Pump

Load Sensing Priority Valve

The Load Sensing Priority Valve is used with the open loop load sense systems that are typically used in steering and braking circuits. The load sense gear pump provides metered priority flow (CF) on demand.

The excess flow (EF) is available for auxiliary circuits. The response time was selected to insure that the operator will not sense a delay or steering "kick" during transient conditions.

Valve Specifications

Rated Pressure	207 BAR (3000PSI)
Rated Inlet Flow	108 L/m (28GPM)
Maximum Controlled Flow (CF)	33 L/m(8.5 GPM)
Bias Pressure	Dynamic - 10 bar (150 PSI) Std. Static - 6.9 bar (100 PSI) Std.
Relief Pressure	34.5-207 bar (500-3000 PSI)
Response Time	70 msec. max. (std. bias spring)
CF Flow Variation over full pressure range	+/- 10%

Pump Specifications

Displacements	9 Available: 8.2cm ³ /r [.50 in ³ /r] thru 30.6 cm ³ /r [1.87in ³ /r]
Mounting	SAE 2-Bolt A Mount SAE 2-Bolt B Mount 4-Bolt European Mount (80mm Pilot)
Ports	Side or Rear
Type	Single or Multiple Configuration

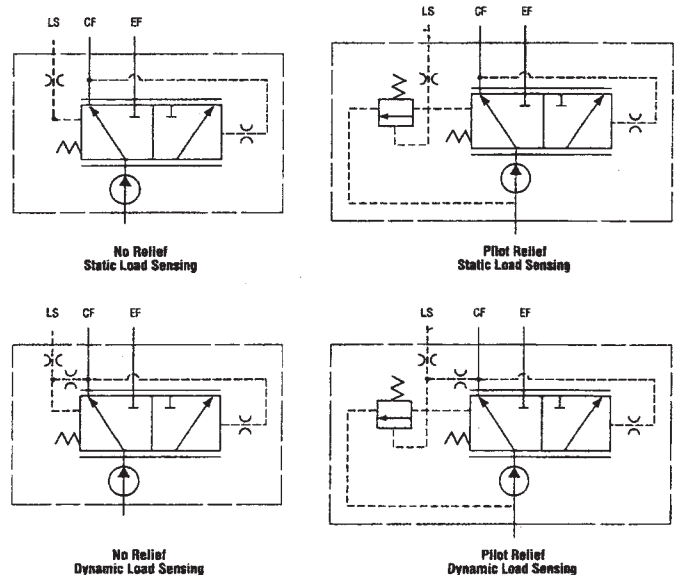
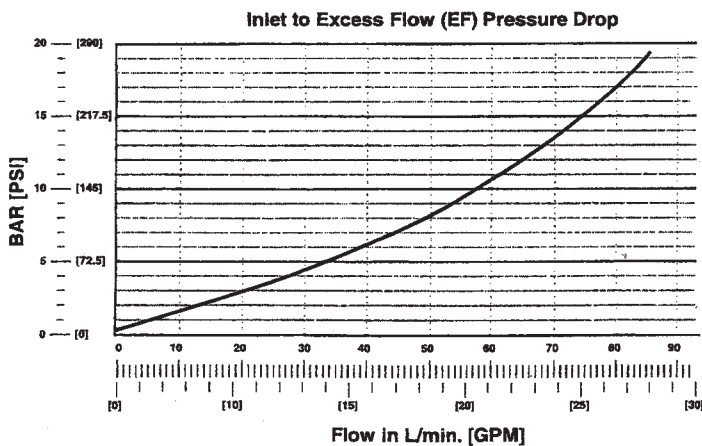

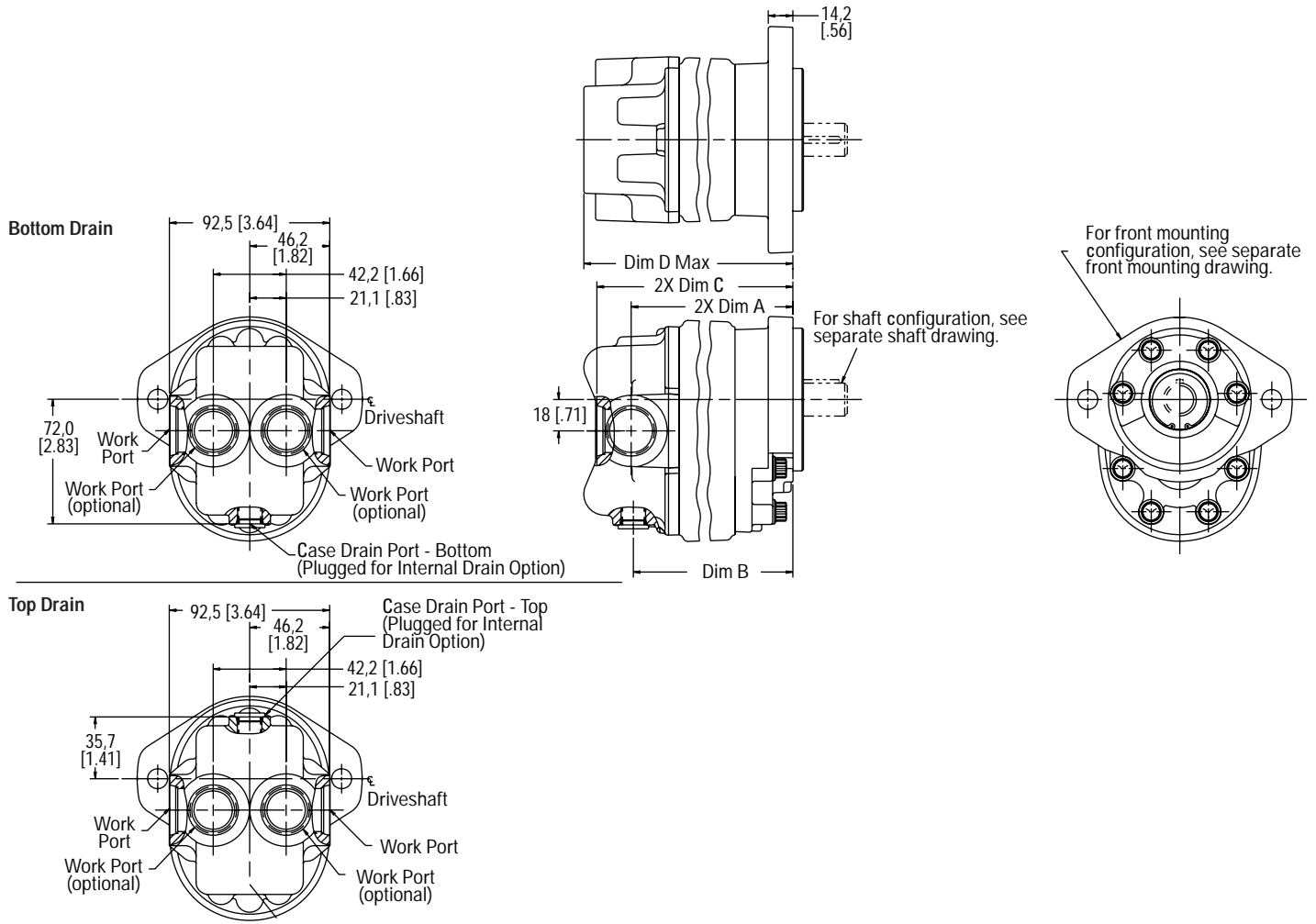

DISPLACEMENT	FRONT MOUNT: 2 BOLT SAE A AND B			
	DIM A	DIM B	DIM C	DIM D
cm ³ /r [in ³ /r]	mm [in]	mm [in]	mm [in]	mm [in]
7.0 [.43]	69.2 [2.72]	67.9 [2.67]	89.0 [3.50]	96.6 [3.80]
8.8 [.54]	71.1 [2.80]	69.8 [2.75]	90.9 [3.58]	98.5 [3.88]
10.2 [.62]	72.6 [2.86]	71.3 [2.81]	92.4 [3.64]	100.0 [3.94]
11.6 [.71]	74.3 [2.93]	73.0 [2.88]	94.1 [3.71]	101.7 [4.01]
12.5 [.76]	75.2 [2.96]	74.0 [2.91]	95.1 [3.74]	102.7 [4.04]
14.6 [.89]	77.5 [3.05]	76.2 [3.00]	97.3 [3.83]	104.9 [4.13]
17.4 [1.06]	80.7 [3.18]	79.4 [3.13]	100.5 [3.96]	108.1 [4.26]
20.3 [1.24]	83.9 [3.30]	82.6 [3.25]	103.7 [4.08]	111.3 [4.38]
23.1 [1.41]	87.1 [3.43]	85.8 [3.38]	106.9 [4.21]	114.5 [4.51]
26.1 [1.59]	90.3 [3.56]	89.0 [3.51]	110.1 [4.34]	117.7 [4.64]
28.8 [1.76]	93.5 [3.68]	92.2 [3.63]	113.3 [4.46]	120.9 [4.76]
31.8 [1.94]	96.7 [3.81]	95.4 [3.76]	116.5 [4.59]	124.1 [4.89]

Series L2 Pump

General Specifications and Performance Data



Rotation	CCW or CW
Mounting Flange	SAE 2 Bolt B
Maximum Continuous [†] Pressure	248 bar [3600 PSI]*
Maximum Intermittent ^{††} Pressure	276 bar [4000 PSI]**
Minimum Speed at Continuous Pressure	750 RPM
Maximum Continuous Inlet Temperature	107°C [225°F]
Minimum Operating Temperature	-29°C [-20°F]
Maximum Inlet Vacuum at 82°C [180°F] and Rated Speed	6.0 In. Hg

† Continuous - pump may be run continuously at these ratings.

†† Intermittent - Intermittent operation, 10% of every minute.

For side load limits consult your Eaton representative.

* 46.7 [2.85] displacement maximum continuous pressure is 224 bar [3250 PSI]
 51.1 [3.12] displacement maximum continuous pressure is 207 bar [3000 PSI]
 55.2 [3.37] displacement maximum continuous pressure is 190 bar [2750 PSI]

** 46.7 [2.85] displacement maximum intermittent pressure is 252 bar [3650 PSI]
 51.1 [3.12] displacement maximum intermittent pressure is 234 bar [3400 PSI]
 55.2 [3.37] displacement maximum intermittent pressure is 217 bar [3150 PSI]

Model	25500	25501	25502	25503	25504	25505	25506	25507	25508
Displacement cm ³ /r [in ³ /r]	21.3 [1.30]	25.4 [1.55]	29.2 [1.78]	33.6 [2.05]	38.2 [2.33]	42.8 [2.61]	46.7 [2.85]	51.1 [3.12]	55.2 [3.37]
Max. Continuous [†] Pressure bar [PSI]	248 [3600]	248 [3600]	248 [3600]	248 [3600]	248 [3600]	248 [3600]	224 [3250]	207 [3000]	190 [2750]
Max. Intermittent ^{††} Pressure bar [PSI]	276 [4000]	276 [4000]	276 [4000]	276 [4000]	276 [4000]	276 [4000]	252 [3650]	234 [3400]	217 [3150]
Rated Speed (RPM)	3500	3000	3000	2750	2750	2500	2500	2500	2250
Minimum Output Flow at 207 bar [3000 PSI] and Rated Speed LPM [GPM]	61,3 [16.2]	64,7 [17.1]	78,0 [20.6]	83,3 [22.0]	94,6 [25.0]	96,1 [25.4]	105,2 [27.8]	115,1 [30.4]	112,0 [29.6]
Input Power at 207 bar [3000 PSI] and Rated Speed and Cont. Pressure kW [HP]	27.5 [36.9]	27.5 [36.9]	31.1 [41.7]	35.3 [47.3]	39.5 [53.0]	39.6 [53.1]	42.4 [56.8]	49.4 [66.2]	48.2 [64.7]

The performance data in the table above and the following graphs was collected using a mineral base oil with a viscosity of 133 SUS at 49° C [120° F]. The following performance graphs are representative of the series.

† Continuous - pump may be run continuously at these ratings.

†† Intermittent - Intermittent operation, 10% of every minute.

Ordering Information

Standard Catalog Assemblies

Standard Catalog Assemblies are built from high quality production parts and are the most economical pumps available in this series. Dimensions and order numbers for Standard Catalog Assemblies are given on pages 6 through 9.

Optional Configurations

Besides the Standard Catalog Assemblies, the L2 Series has several optional features. Flow divider and tandem backplates are available. Multiple gear pumps can also be built. If a variation from the Standard Catalog Assemblies is required, use the model codes on pages 10 through 18.

Series L2 Pump Performance Data

Output Flow vs Speed

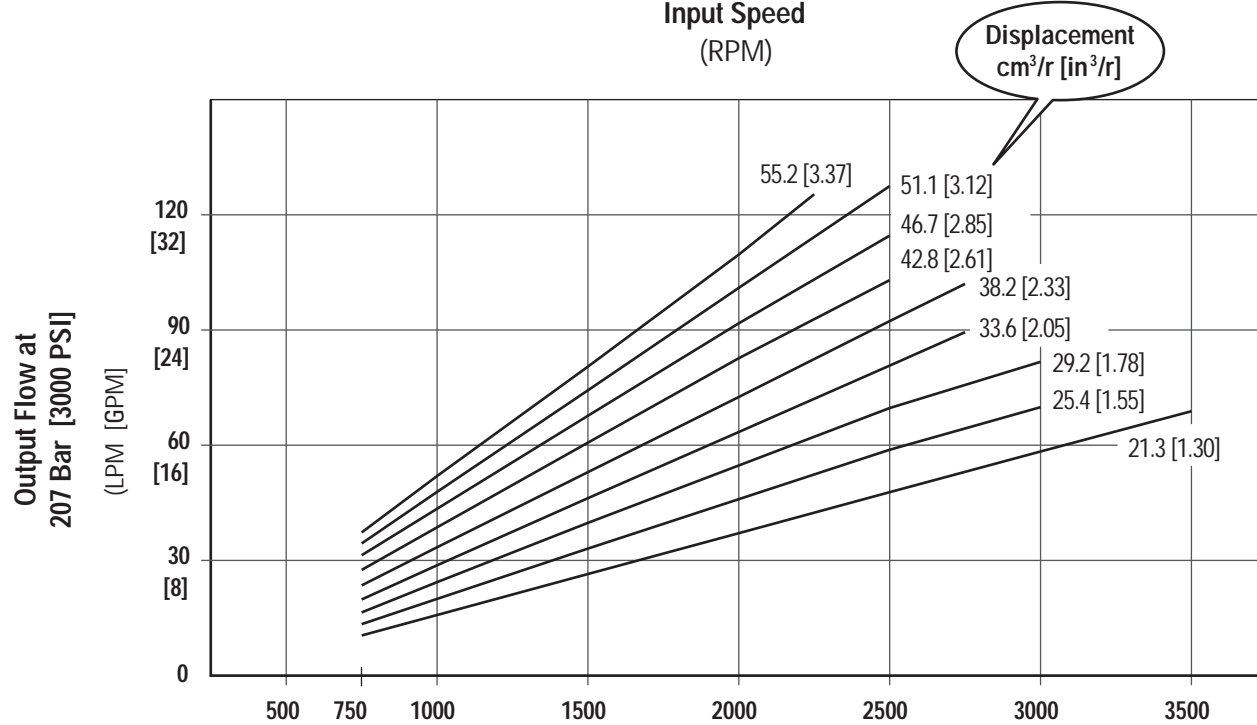
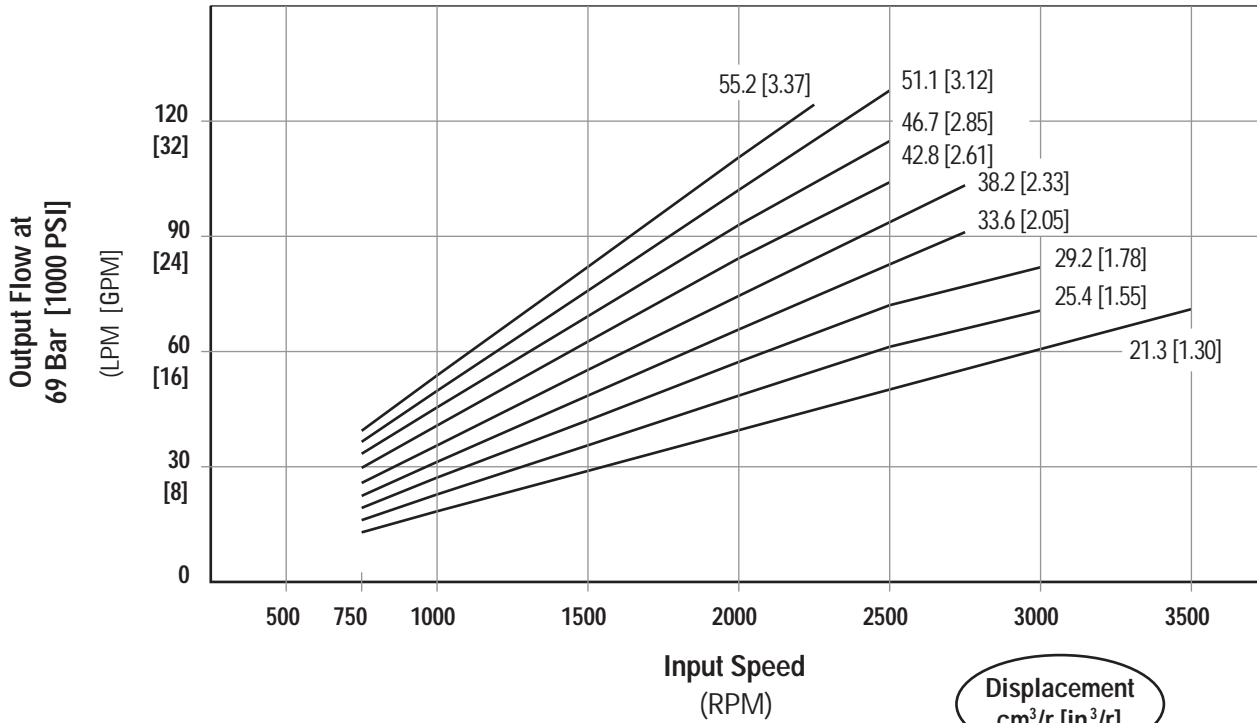

Series L2 Pump Performance Data

Input Power vs Speed

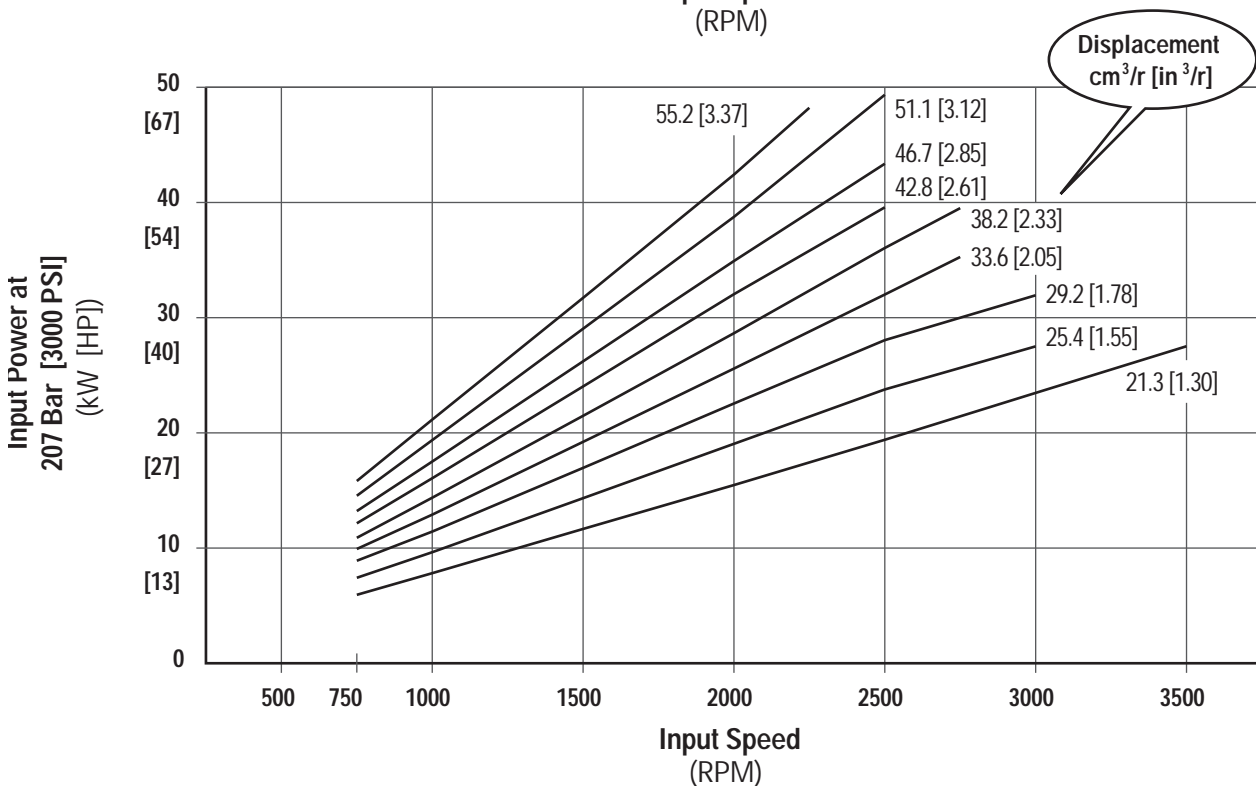
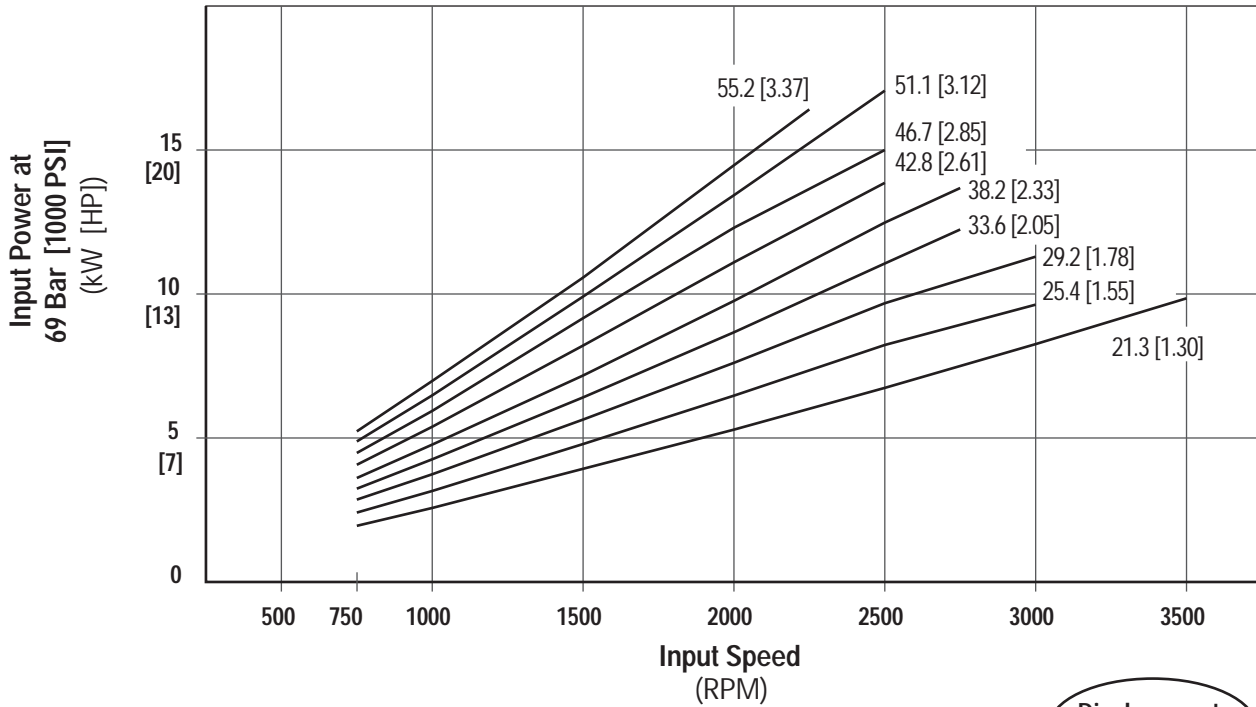

The performance data show in the graphs are representative of this series. Tests were performed per SAE specifications using mineral base oil with a viscosity of 133 SUS at 49° C [120° F].

Series L2 Pump Standard Catalog Assemblies - Dimensions

All dimensions are in mm [in].

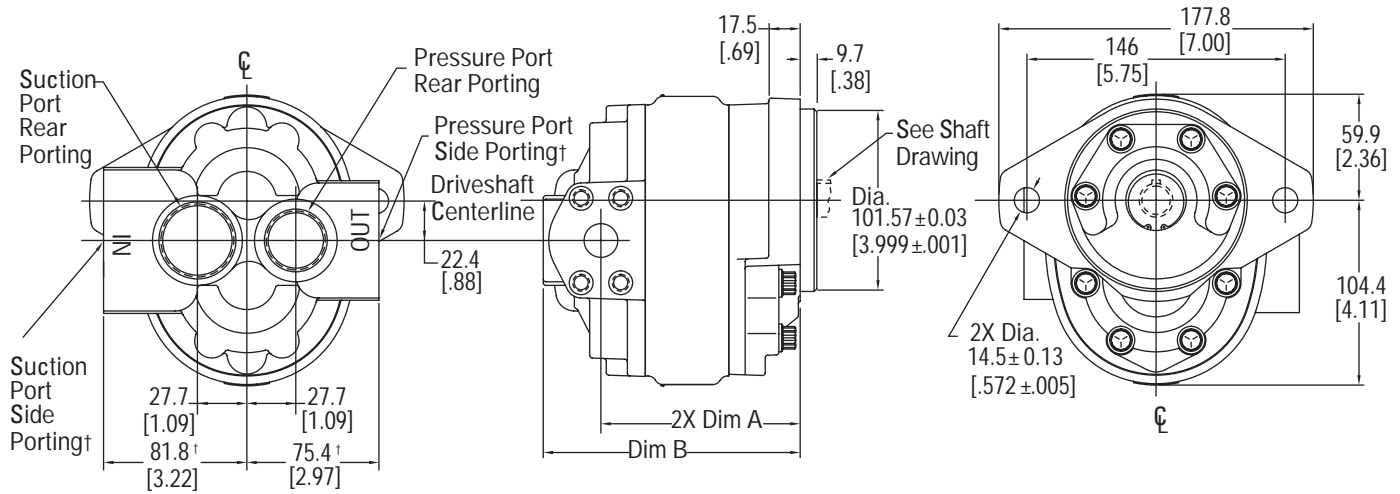

Left Hand Rotation Shown

† For split flange porting subtract .8 [.03], available in side porting only

Model	25500	25501	25502	25503	25504	25505	25506	25507	25508
Displacement (cm ³ /r [in ³ /r])	21.3 [1.30]	25.4 [1.55]	29.2 [1.78]	33.6 [2.05]	38.2 [2.33]	42.8 [2.61]	46.7 [2.85]	51.1 [3.12]	55.2 [3.37]
Dimension A (mm [in.])	84.8 [3.34]	88.2 [3.47]	91.7 [3.61]	95.1 [3.75]	98.6 [3.88]	102.0 [4.02]	105.3 [4.14]	109.0 [4.29]	112.4 [4.43]
Dimension B (mm [in.])	117.3 [4.62]	120.8 [4.75]	124.2 [4.89]	127.7 [5.03]	131.1 [5.16]	134.6 [5.30]	137.8 [5.42]	141.5 [5.57]	145.0 [5.71]

7/8 Inch Straight Key

Maximum Input Torque††
170 Nm [1500 lb-in]

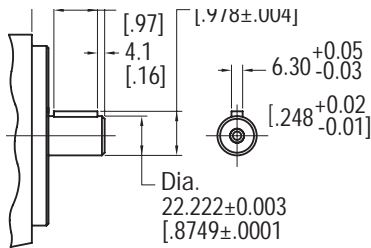

7/8 Inch 13 Tooth Spline

Maximum Input Torque††
209 Nm [1850 lb-in]

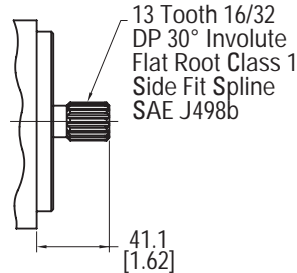

7/8 Inch 41 Tooth Spline

Maximum Input Torque††
316 Nm [2800 lb-in]

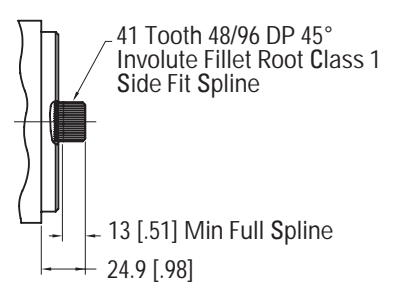

* Multiple pump input torque limitations:

the total torque for multiple pump displacements and pressure combinations cannot exceed the maximum input torque rating of the shaft. The proper formula is Pressure times Displacement divided by 6.28.

Series L2 Pump Order Numbers

RIGHT HAND ROTATION PRODUCT NO	LEFT HAND ROTATION PRODUCT NO	SHAFT	PORT LOCATION	SAE PRESSURE PORT SIZE	SAE SUCTION PORT SIZE
Model 25500 – 21.3 cm³/r [1.30 in³/r] Displacement					
25500-RSA	25500-LSA	13 T Spline	Side	1-1/16-12	1-5/8-12
25500-RSB	25500-LSB	13 T Spline	Rear	1-1/16-12	1-5/8-12
25500-RSC	25500-LSC	7/8 Keyed	Side	1-1/16-12	1-5/8-12
25500-RSD	25500-LSD	7/8 Keyed	Rear	1-1/16-12	1-5/8-12
25500-RSE	25500-LSE	13 T Spline	Side	3/4 Split Flange	1-1/4 Split Flange
25500-RSF	25500-LSF	7/8 Keyed	Side	3/4 Split Flange	1-1/4 Split Flange
Model 25501 – 25.4 cm³/r [1.55 in³/r] Displacement					
25501-RSA	25501-LSA	13 T Spline	Side	1-1/16-12	1-5/8-12
25501-RSB	25501-LSB	13 T Spline	Rear	1-1/16-12	1-5/8-12
25501-RSC	25501-LSC	7/8 Keyed	Side	1-1/16-12	1-5/8-12
25501-RSD	25501-LSD	7/8 Keyed	Rear	1-1/16-12	1-5/8-12
25501-RSE	25501-LSE	13 T Spline	Side	3/4 Split Flange	1-1/4 Split Flange
25501-RSF	25501-LSF	7/8 Keyed	Side	3/4 Split Flange	1-1/4 Split Flange
Model 25502 – 29.2 cm³/r [1.78 in³/r] Displacement					
25502-RSA	25502-LSA	13 T Spline	Side	1-1/16-12	1-5/8-12
25502-RSB	25502-LSB	13 T Spline	Rear	1-1/16-12	1-5/8-12
25502-RSC	25502-LSC	7/8 Keyed	Side	1-1/16-12	1-5/8-12
25502-RSD	25502-LSD	7/8 Keyed	Rear	1-1/16-12	1-5/8-12
25502-RSE	25502-LSE	13 T Spline	Side	3/4 Split Flange	1-1/4 Split Flange
25502-RSF	25502-LSF	7/8 Keyed	Side	3/4 Split Flange	1-1/4 Split Flange
Model 25503 – 33.6 cm³/r [2.05 in³/r] Displacement					
25503-RSA	25503-LSA	13 T Spline	Side	1-1/16-12	1-5/8-12
25503-RSB	25503-LSB	13 T Spline	Rear	1-1/16-12	1-5/8-12
25503-RSC	25503-LSC	7/8 Keyed	Side	1-1/16-12	1-5/8-12
25503-RSD	25503-LSD	7/8 Keyed	Rear	1-1/16-12	1-5/8-12
25503-RSE	25503-LSE	13 T Spline	Side	3/4 Split Flange	1-1/4 Split Flange
25503-RSF	25503-LSF	7/8 Keyed	Side	3/4 Split Flange	1-1/4 Split Flange
Model 25504 – 38.2 cm³/r [2.33 in³/r] Displacement					
25504-RSA	25504-LSA	13 T Spline	Side	1-1/16-12	1-5/8-12
25504-RSB	25504-LSB	13 T Spline	Rear	1-1/16-12	1-5/8-12
25504-RSC	25504-LSC	7/8 Keyed	Side	1-1/16-12	1-5/8-12
25504-RSD	25504-LSD	7/8 Keyed	Rear	1-1/16-12	1-5/8-12
25504-RSE	25504-LSE	13 T Spline	Side	3/4 Split Flange	1-1/4 Split Flange
25504-RSF	25504-LSF	7/8 Keyed	Side	3/4 Split Flange	1-1/4 Split Flange

Series L2 Pump Order Numbers

RIGHT HAND ROTATION PRODUCT NO	LEFT HAND ROTATION PRODUCT NO	SHAFT	PORT LOCATION	SAE PRESSURE PORT SIZE	SAE SUCTION PORT SIZE
Model 25505 – 42.8 cm³/r [2.61 in³/r] Displacement					
25505-RSA	25505-LSA	13 T Spline	Side	1-1/16-12	1-5/8-12
25505-RSB	25505-LSB	13 T Spline	Rear	1-1/16-12	1-5/8-12
25505-RSC	25505-LSC	7/8 Keyed	Side	1-1/16-12	1-5/8-12
25505-RSD	25505-LSD	7/8 Keyed	Rear	1-1/16-12	1-5/8-12
25505-RSE	25505-LSE	13 T Spline	Side	3/4 Split Flange	1-1/4 Split Flange
25505-RSF	25505-LSF	7/8 Keyed	Side	3/4 Split Flange	1-1/4 Split Flange
Model 25506 – 46.7 cm³/r [2.85 in³/r] Displacement					
25506-RSA	25506-LSA	13 T Spline	Side	1-1/16-12	1-5/8-12
25506-RSB	25506-LSB	13 T Spline	Rear	1-1/16-12	1-5/8-12
25506-RSC	25506-LSC	7/8 Keyed	Side	1-1/16-12	1-5/8-12
25506-RSD	25506-LSD	7/8 Keyed	Rear	1-1/16-12	1-5/8-12
25506-RSE	25506-LSE	13 T Spline	Side	3/4 Split Flange	1-1/4 Split Flange
25506-RSF	25506-LSF	7/8 Keyed	Side	3/4 Split Flange	1-1/4 Split Flange
Model 25507 – 51.1 cm³/r [3.12 in³/r] Displacement					
25507-RSA	25507-LSA	13 T Spline	Side	1-1/16-12	1-5/8-12
25507-RSB	25507-LSB	13 T Spline	Rear	1-1/16-12	1-5/8-12
25507-RSC	25507-LSC	7/8 Keyed	Side	1-1/16-12	1-5/8-12
25507-RSD	25507-LSD	7/8 Keyed	Rear	1-1/16-12	1-5/8-12
25507-RSE	25507-LSE	13 T Spline	Side	3/4 Split Flange	1-1/4 Split Flange
25507-RSF	25507-LSF	7/8 Keyed	Side	3/4 Split Flange	1-1/4 Split Flange
Model 25508 – 55.2 cm³/r [3.37 in³/r] Displacement					
25508-RSA	25508-LSA	13 T Spline	Side	1-1/16-12	1-5/8-12
25508-RSB	25508-LSB	13 T Spline	Rear	1-1/16-12	1-5/8-12
25508-RSC	25508-LSC	7/8 Keyed	Side	1-1/16-12	1-5/8-12
25508-RSD	25508-LSD	7/8 Keyed	Rear	1-1/16-12	1-5/8-12
25508-RSE	25508-LSE	13 T Spline	Side	3/4 Split Flange	1-1/4 Split Flange
25508-RSF	25508-LSF	7/8 Keyed	Side	3/4 Split Flange	1-1/4 Split Flange

Series L2 Pump

Optional Configurations

The L2 Series gear pump components can be assembled into many optional configurations. The versatile design allows you to assemble a pump to meet your specific needs.

Model codes for single and multiple pumps along with the component part dimension drawings are given on the following pages.

Single Gear Pump with Split- Flange Ports

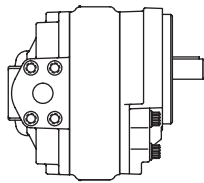

Double Gear Pump with Common Suction Port

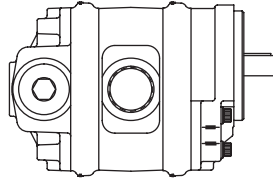

Triple Gear Pump with Two Suction Ports

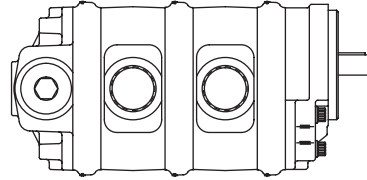

Single Gear Pump with Flow Divider

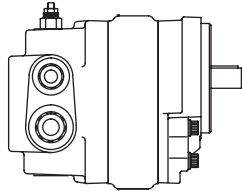

Double Gear Pump with Flow Divider

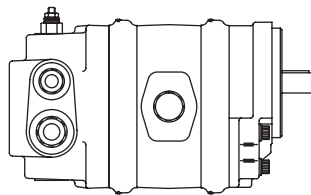

Triple Gear Pump with Flow Divider

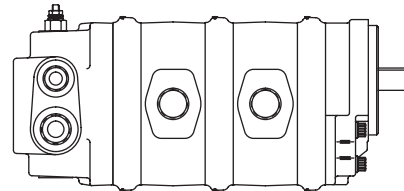

Single Gear Pump with SAE A Flange Auxiliary Mount

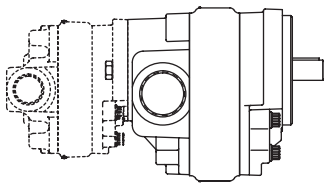

Double Gear Pump with Common Suction Port and SAE A Flange Auxiliary Mount

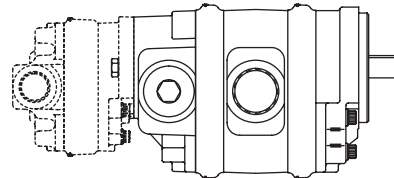

Triple Gear Pump with Two Suction Ports and SAE A Flange Auxiliary Mount

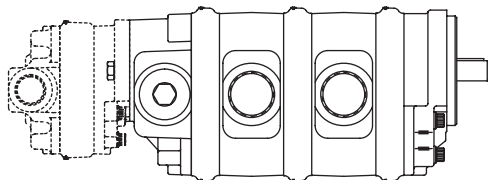

Series L2 Pump Component Parts - Dimensions

All dimensions are in mm [in].

Front Plate

SAE 2 Bolt B Mount.
Used on all Standard
Catalog Assemblies.

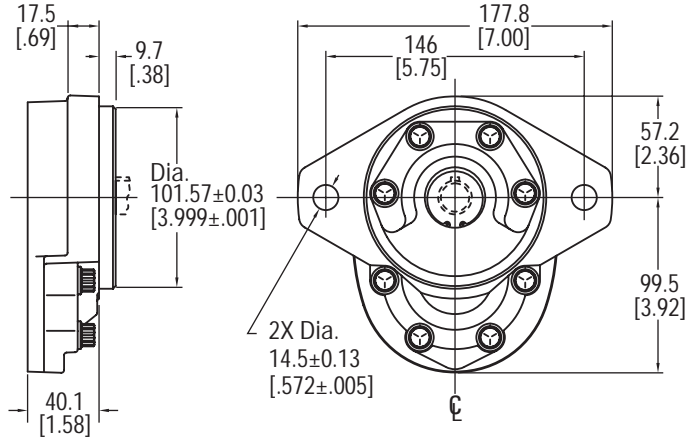

Body

Used on Single and
Multiple Pumps

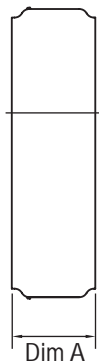

Displacement cm ³ /r [in ³ /r]	Dimension A mm [in.]
21.3 [1.30]	19.8 [0.78]
25.4 [1.55]	23.1 [0.91]
29.2 [1.78]	26.7 [1.05]
33.6 [2.05]	30.0 [1.18]
38.2 [2.33]	1.32 [0.052]
42.8 [2.61]	37.1 [1.46]
46.7 [2.85]	1.59 [0.063]
51.1 [3.12]	43.9 [1.73]
55.2 [3.37]	47.5 [1.87]

Backplate

Used on Single and
Multiple Pumps

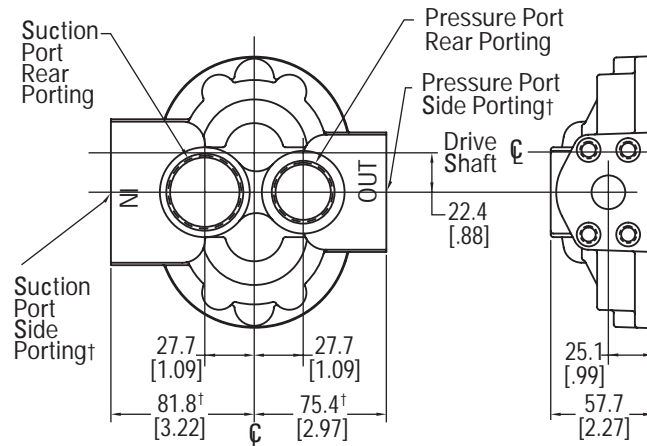

Left Hand Rotation Shown

† For split flange porting subtract .8 [0.03], available in side porting only

Series L2 Pump Component Parts - Dimensions

All dimensions are in mm [in].

Flow Divider Backplate

Used on Single and Multiple Pumps

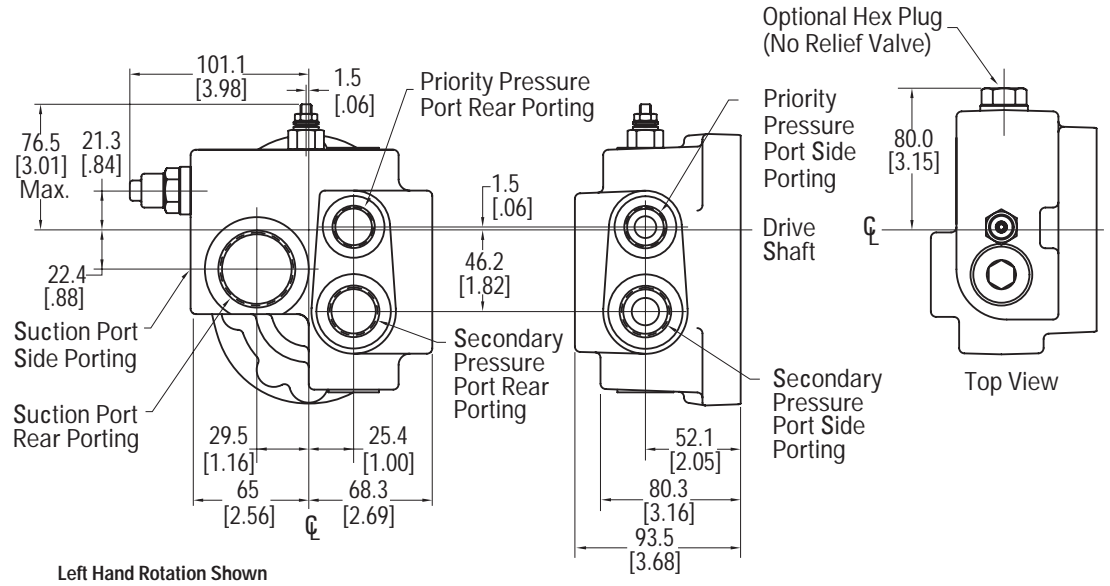

Series L2 Pump Component Parts - Dimensions

All dimensions are in mm [in].

Tandem Backplate with SAE 2 Bolt A Flange

Used on Single and
Multiple Pumps

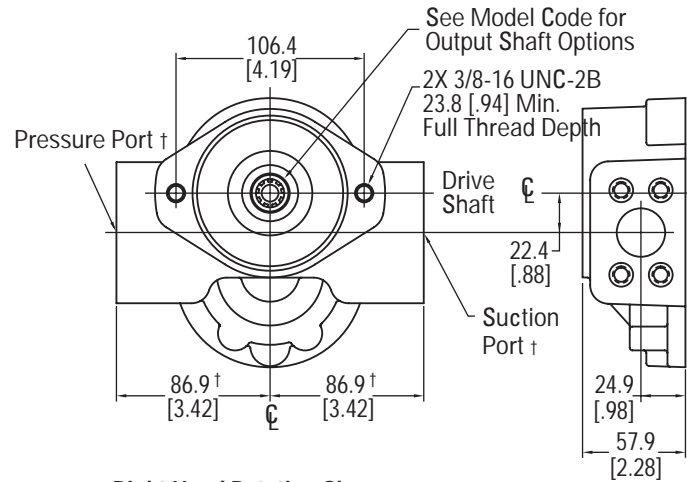

Right Hand Rotation Shown

† For split flange porting subtract .8 [.03]

Spacer

Used with 11 Tooth Spline
Output Shaft

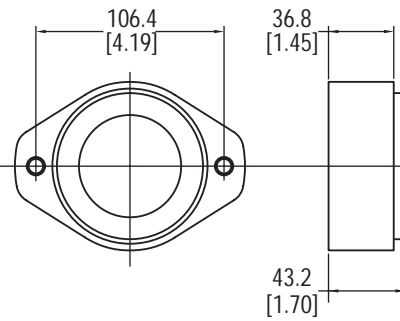

Adaptor Plate

Used on Multiple Pumps

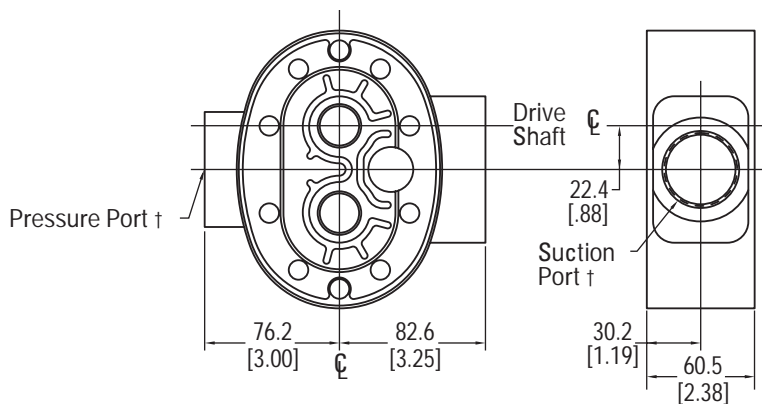

Right Hand Rotation Shown

† For split flange porting subtract .8 [.03]

Series L2 Pump

Model Code - Single

L2 gear pumps can be ordered by using the following Model Code.

A twenty-three digit coding system has been designed to identify all of the features available on L2 single gear pumps. The characters and their relative positions within the code identify specific features.

Use the Model Code Matrix as an aid when assembling the model code for the pump with the features you desire. It may be helpful to photocopy the matrix and write the numbers and letters into the boxes as you select features.

All twenty-three digits of the code must be submitted when ordering. The seven zeros at the end of the model code are for factory use, be sure to include them when ordering.

All dimensions are in inches.

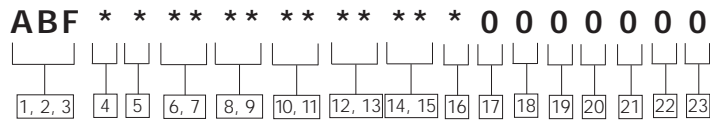

1, 2, 3 L2 Series

ABF – Gear Pump - Single Unit

4 Unit Type

A – Plain
B – Flow Divider with/without Relief Valve (Pos. 14-15)

5 Input Rotation (viewed from input shaft end)

L – Left-hand Rotation CCW
R – Right-hand Rotation CW

6, 7 Displacement (cm³/r [in³/r])

00 = 21.3 [1.30]
01 = 25.4 [1.55]
02 = 29.2 [1.78]
03 = 33.6 [2.05]
04 = 38.2 [2.33]
05 = 42.8 [2.61]
06 = 46.7 [2.85]
07 = 51.1 [3.12]
08 = 55.2 [3.37]

8, 9 Input Shaft

AA = 7/8 Inch Dia. 13 Tooth Spline 16/32 Pitch Shaft Extension 41.1 [1.62]

AB = 7/8 Inch Dia. Straight Keyed, Keyway 6.4 X 25.4 [.25 X 1.00] Shaft Extension 41.1 [1.62]

AD = 7/8 Inch Dia. 41 Tooth Spline 48/96 Pitch Shaft Extension 24.9 [.98]

10, 11 Ports, Sizes and Location- Backplate

01 = 1 5/8-12 Suction; 1 1/16-12 Pressure SAE Straight Thread O-ring Ports - Side

02 = 1 5/8-12 Suction; 1 1/16-12 Pressure SAE Straight Thread O-ring Ports - Rear

03 = 1 1/4 Suction; 3/4 Pressure Split Flange Ports - Side

04 = 1 5/8-12 Suction; 7/8-14 Priority Pressure; 1 1/16-12 Secondary Pressure SAE Straight Thread O-ring Ports - Side

05 = 1 5/8-12 Suction; 7/8-14 Priority Pressure; 1 1/16-12 Secondary Pressure SAE Straight Thread O-ring Ports - Rear

12, 13 Priority Flow Divider Setting (LPM [GPM])

00 = No Flow Setting

AA = 3.8 [1.00]

AB = 5.7 [1.50]

AC = 7.6 [2.00]

AD = 9.5 [2.50]

AE = 11.4 [3.00]

AF = 13.3 [3.50]

AG = 15.1 [4.00]

AH = 17.0 [4.50]

AJ = 18.9 [5.00]

AK = 20.8 [5.50]

AL = 22.7 [6.00]

AN = 26.5 [7.00]

AP = 30.3 [8.00]

AR = 34.1 [9.00]

AS = 37.8 [10.00]

14, 15 Relief Valve Full Flow Setting (bar [PSI])

00 = No Relief Valve Setting

AA = 34.5 [500]

AB = 51.7 [750]

AC = 68.9 [1000]

AD = 86.2 [1250]

AE = 103.4 [1500]

AF = 120.6 [1750]

AG = 137.9 [2000]

AH = 155.1 [2250]

AJ = 172.4 [2500]

AK = 189.6 [2750]

AL = 206.8 [3000]

16 Auxiliary Rear Mount

0 = None

B = 2 Bolt A SAE Flange Series 82-2 Output Shaft Accepts 9 Tooth Spline 16/32 Pitch, Shaft Extension 31.8 [1.25]

C = 2 Bolt A SAE Flange Series 82-2, With 11 Tooth 16/32 Pitch External Spline Output Shaft, 17.5 [.69] Minimum Full Spline, Requires Spacer and Coupler to Accept 31.8 [1.25] Mating Shaft Extension

18 Test Data

0 - Generic

A - Unit Specific (required for flow divider and relief valve options.)

19, 20 Special Features

00 - No Special Features

AB - Viton Shaft Seal

21, 22 Paint

00 - None

0A - Red Primer

0B - Black

23 Identification

0 - Standard

24 Design Code

A - A

Series L2 Pump

Model Code - Multiple

Multiple L2 gear pumps can be ordered by using the following Model Code.

A twenty-nine digit coding system has been designed to identify all of the features available on L2 double and triple gear pumps. The characters and their relative positions within the code identify specific features.

Use the Model Code Matrix as an aid when assembling the model code for the pump with the features you desire. It may be helpful to photocopy the matrix and write the numbers and letters into the boxes as you select features.

All twenty-nine digits of the code must be submitted when ordering. The seven zeros at the end of the model code are for factory use, be sure to include them when ordering.

All dimensions are in inches.

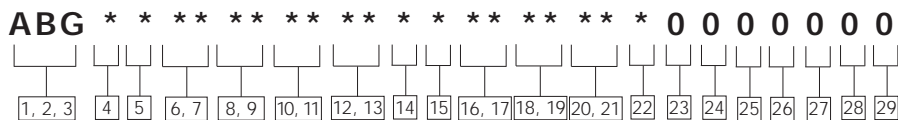

1, 2, 3 L2 Series

ABG – Gear Pump - Multiple Unit

4 Unit Type

A – Plain
B – Flow Divider with/without Relief Valve (Pos. 20-21)

5 Input Rotation (viewed from input shaft end)

L – Left-hand Rotation CCW
R – Right-hand Rotation CW

6, 7 Displacement (cm³/r [in³/r])

00 = 21.3 [1.30]
01 = 25.4 [1.55]
02 = 29.2 [1.78]
03 = 33.6 [2.05]
04 = 38.2 [2.33]
05 = 42.8 [2.61]
06 = 46.7 [2.85]
07 = 51.1 [3.12]
08 = 55.2 [3.37]

8, 9 Displacement of Center Section (cm³/r [in³/r])

00 = 21.3 [1.30]
01 = 25.4 [1.55]
02 = 29.2 [1.78]
03 = 33.6 [2.05]
04 = 38.2 [2.33]
05 = 42.8 [2.61]
06 = 46.7 [2.85]
07 = 51.1 [3.12]
08 = 55.2 [3.37]
99 = No Center Displacement

10, 11 Displacement of Rear Section (cm³/r [in³/r])

00 = 21.3 [1.30]
01 = 25.4 [1.55]
02 = 29.2 [1.78]
03 = 33.6 [2.05]
04 = 38.2 [2.33]
05 = 42.8 [2.61]
06 = 46.7 [2.85]
07 = 51.1 [3.12]
08 = 55.2 [3.37]

12, 13 Input Shaft

AA = 7/8 Inch Dia. 13 Tooth Spline 16/32 Pitch Shaft Extension 41.1 [1.62]

AB = 7/8 Inch Dia. Straight Keyed, Keyway 6.4 X 25.4 [.25 X 1.00] Shaft Extension 41.1 [1.62]

AD = 7/8 Inch Dia. 41 Tooth Spline 48/96 Pitch Shaft Extension 24.9 [.98]

14 Front Adaptor Ports

1 = 1 5/8-12 Suction; 1 1/16-12 Pressure – SAE Straight Thread O-ring Ports
3 = 1 1/4 Suction; 3/4 Pressure Split Flange Ports, Common Suction

15 Rear Adaptor Ports (triple pumps)

0 = No Rear Adaptor
1 = 1 5/8-12 Suction; 1 1/16-12 Pressure – SAE Straight Thread O-ring Ports
3 = 1 1/4 Suction; 3/4 Pressure Split Flange Ports, Common Suction

16, 17 Ports, Sizes and Location- Backplate

02 = 1 5/8-12 Suction; 1 1/16-12 Pressure SAE Straight Thread O-ring Ports - Rear

03 = 1 1/4 Suction; 3/4 Pressure Split Flange Ports - Side

04 = 1 5/8-12 Suction; 7/8-14 Priority Pressure; 1 1/16-12 Secondary Pressure SAE Straight Thread O-ring Ports - Side

05 = 1 5/8-12 Suction; 7/8-14 Priority Pressure; 1 1/16-12 Secondary Pressure SAE Straight Thread O-ring Ports - Rear

06 = 1 5/8-12 Suction (Plugged); 7/8-14 Priority Pressure; 1 1/16-12 Secondary Pressure SAE Straight Thread O-ring Ports - Rear

07 = 1 5/8-12 Suction (Plugged); 1 1/16-12 Pressure SAE Straight Thread O-ring Ports - Rear

08 = 1 1/4 Suction; 3/4 Pressure Split Flange Ports - Side

18, 19 Priority Flow Divider Setting (LPM [GPM])

00 = No Flow Setting

AA = 3.8 [1.00]

AB = 5.7 [1.50]

AC = 7.6 [2.00]

AD = 9.5 [2.50]

AE = 11.4 [3.00]

AF = 13.3 [3.50]

AG = 15.1 [4.00]

AH = 17.0 [4.50]

AJ = 18.9 [5.00]

AK = 20.8 [5.50]

AL = 22.7 [6.00]

AN = 26.5 [7.00]

AP = 30.3 [8.00]

AR = 34.1 [9.00]

AS = 37.8 [10.00]

20, 21 Relief Valve Full Flow Setting (bar [PSI])

00 = No Relief Valve Setting

AA = 34.5 [500]

AB = 51.7 [750]

AC = 68.9 [1000]

AD = 86.2 [1250]

AE = 103.4 [1500]

AF = 120.6 [1750]

AG = 137.9 [2000]

AH = 155.1 [2250]

AJ = 172.4 [2500]

AK = 189.6 [2750]

AL = 206.8 [3000]

22 Auxiliary Rear Mount

0 = None

B = 2 Bolt A SAE Flange Series 82-2 Output Shaft Accepts 9 Tooth Spline 16/32 Pitch, Shaft Extension 31.8 [1.25]

C = 2 Bolt A SAE Flange Series 82-2, With 11 Tooth 16/32 Pitch External Spline Output Shaft, 17.5 [.69] Minimum Full Spline, Requires Spacer and Coupler to Accept 31.8 [1.25] Mating Shaft Extension

23 Test Data

0 - Generic

A - Unit Specific (required for flow divider and relief valve options.)

24, 25 Special Features

00 - No Special Features

AA - Viton Shaft Seal

26, 27 Paint

00 - None

0A - Red Primer

0B - Black

28 Identification

0 - Standard

29 Design Code

A - A

Eaton
14615 Lone Oak Road
Eden Prairie, MN 55344
USA
Tel: 952 937-9800
Fax: 952 974-7722
www.hydraulics.eaton.com

Eaton
20 Rosamond Road
Footscray
Victoria 3011
Australia
Tel: (61) 3 9319 8222
Fax: (61) 3 9318 5714

Eaton
Dr.-Reckeweg-Str. 1
D-76532 Baden-Baden
Germany
Tel: (49) 7221 682-0
Fax: (49) 7221 682-788

