

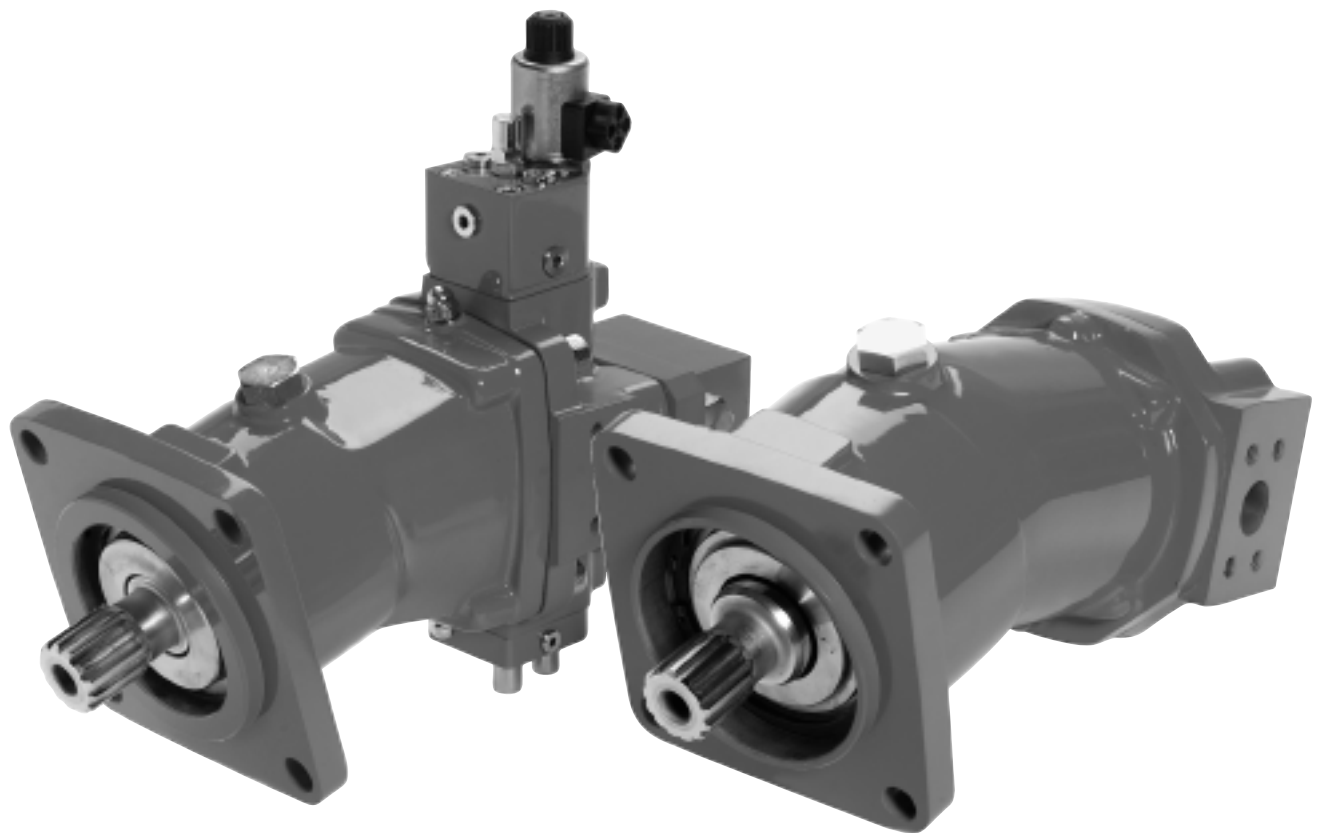

Bent Axis Motors

Parts and Service



Bent Axis Motors

Table of Contents

Introduction	3
Identification Tag	3
Tools Required	3
Parts Assembly Drawing and List	
Bent Axis Variable	4
Bent Axis Fixed	5
Parts	
Pre-loading Spring	6
BAV Seal Kits	7
BAF Seal Kits	7
Shaft & Bushing Kits	8
Disassembly	9-13
Check Condition of Parts	14-15
Assembly	16-21
Torque Values	21
Installation Guidelines	22-23
Controls	
Technical Data	24
Testing Procedures	25
Controls EA, EB, EC, ED	26-28
Controls HA	29
Controls HB	30
Controls H1	31
Controls H2	32
Controls M1, M2	33-35
Controls PA	36-37
Controls PB	38-39
Controls E5-E6	40-41
BAV Critical Dimensions	42
Special Tools	43

Introduction

This manual will provide you with service information and procedures for disassembly and assembly of Eaton® Fixed and Variable Displacement Bent Axis Motors. Procedures outlined in this manual will allow you to better service your motors and obtain the best results possible. To ensure accuracy of repair and prevent part loss or damage, certain components or subassemblies are disassembled, inspected, and reassembled when removed from the motor.

Note: All requests or inquiries must be accompanied by the complete model and serial number.

Important: Cleanliness is extremely important when repairing a hydrostatic motor. Before disconnecting the lines, clean foreign material from exterior of unit. Work in a clean area. Clean all metal parts in clean solvent.

Dry parts with clean compressed air. Avoid cleaning parts with cloth or paper towel as these can introduce contamination. Visually inspect all mating surfaces. Replace any components that have scratches, burrs or evidence of smeared material. Don't use abrasive tools including coarse grit papers, files or grinders on internal parts.

Note: All torque specifications are for lubricated threads. Bolts for gasketed surfaces should be checked for proper torque.

A good service policy is to replace all old seals with new seals whenever unit is disassembled. Lubricate seals with petroleum jelly. Use only clean, recommended oil when assembling unit. See Hydrostatic Fluid Recommendations in publication 03-401 and 03-405.

Identification Tag

Refer to specific motor assembly part listings for your Eaton motor when ordering replacement parts. Parts lists are available from Eaton. Sample tag shows motor identification.

When ordering replacement parts, you must include the following information:

A - Part Number/Displacement (cu.in./rev.)

BAF Fixed Displacement Motors

11	183BAXXXXXA
20, 30	383BAXXXXXA
40, 44,	583BAXXXXXA
75, 87, 108, 161	783BAXXXXXA
225	983BAXXXXXA

BAV Variable Displacement Motors

55, 75, 108	524BAXXXXXA
161	724BAXXXXXA
225	924BAXXXXXA

Displacement

Base Part Number

Design Code

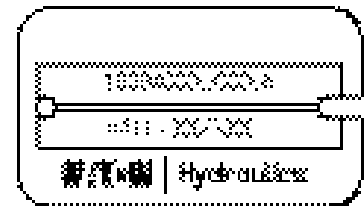

Serial Number Example:

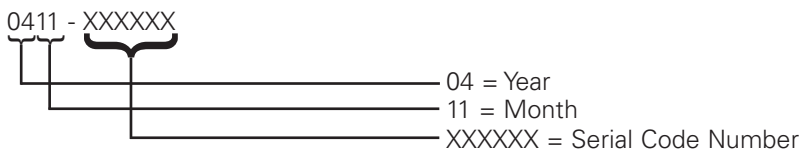

Tools Required

- Allen Key
- Depth Vernier Caliper
- Snap Ring Closing and Expanding Pliers
- Screwdrivers
- Shaft Puller
- Rubber Mallet
- Dial Indicator
- Torque Wrench

Specifications:

Continuous max. pressure 5100 psi (350 bar)
Peak pressure 6500 psi (450 bar)
Max pressure into casing 35 psi (1,5 bar)
Max. circuit fluid temperature 167°F (+75°C)
Max. leakage fluid temperature 195°F (+90°C)
Viscosity range 10-800 cSt (1,85 , 105°E)
Normal viscosity range 15-60 cSt (2,3,8°E)
Oil cleanliness ISO-DIN 4406 = 19/16

Parts

Assembly and List (BAV- Bent Axis Variable Displacement)

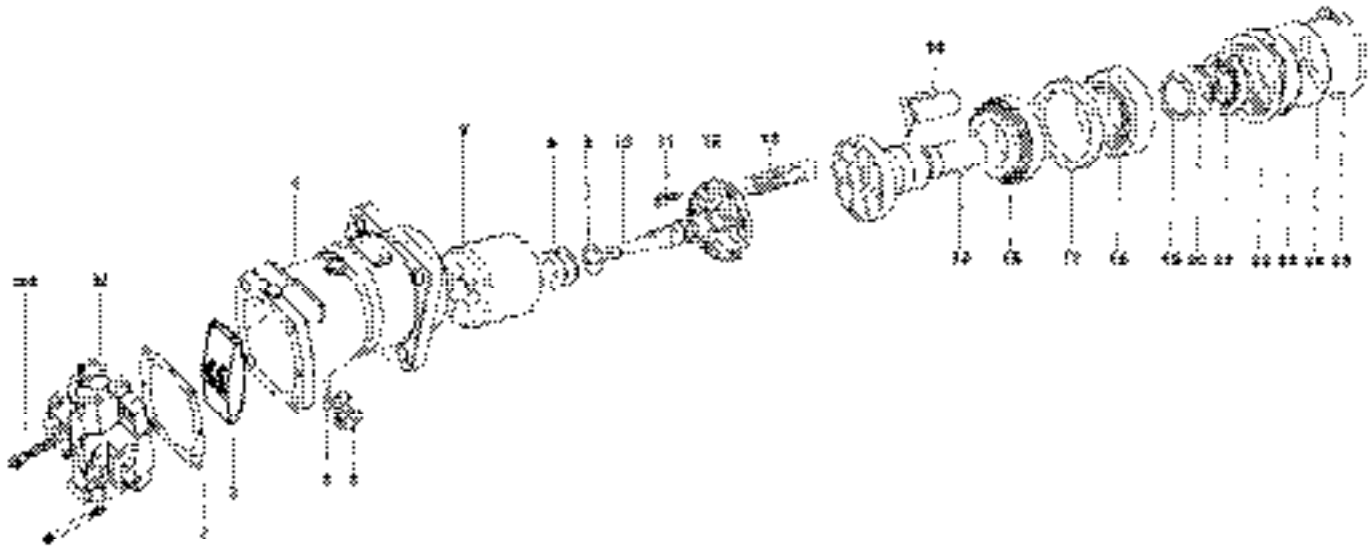

TABLE 1.0
BAV PARTS

BENT AXIS VARIABLE DISPLACEMENT MODEL PARTS

2.	Gasket	22.	Shims
3.	Valve Plate	23.	Seal Cover
4.	Housing	24.	O-Ring*
5.	Washer	25.	Circlip
6.	Plug	26.	Bolt
7.	Cylinder Barrel	32.	End Cover
8.	Belleville Washers (As Required)		
9.	Shims (As Required)		
10.	Center Pivot		
11.	Bolt		
12.	Retaining Plate		
13.	Piston Assembly: Piston + Rod		
14.	Straight Keyed Shaft		
15.	Splined Shaft		
16.	Tapered Roller Bearing		
17.	Spacer		
18.	Ball Bearing		
19.	Spacer		
20.	Retaining Ring		
21.	Shaft Seal*		

Parts

Assembly and List (BAF– Bent Axis Fixed Displacement)

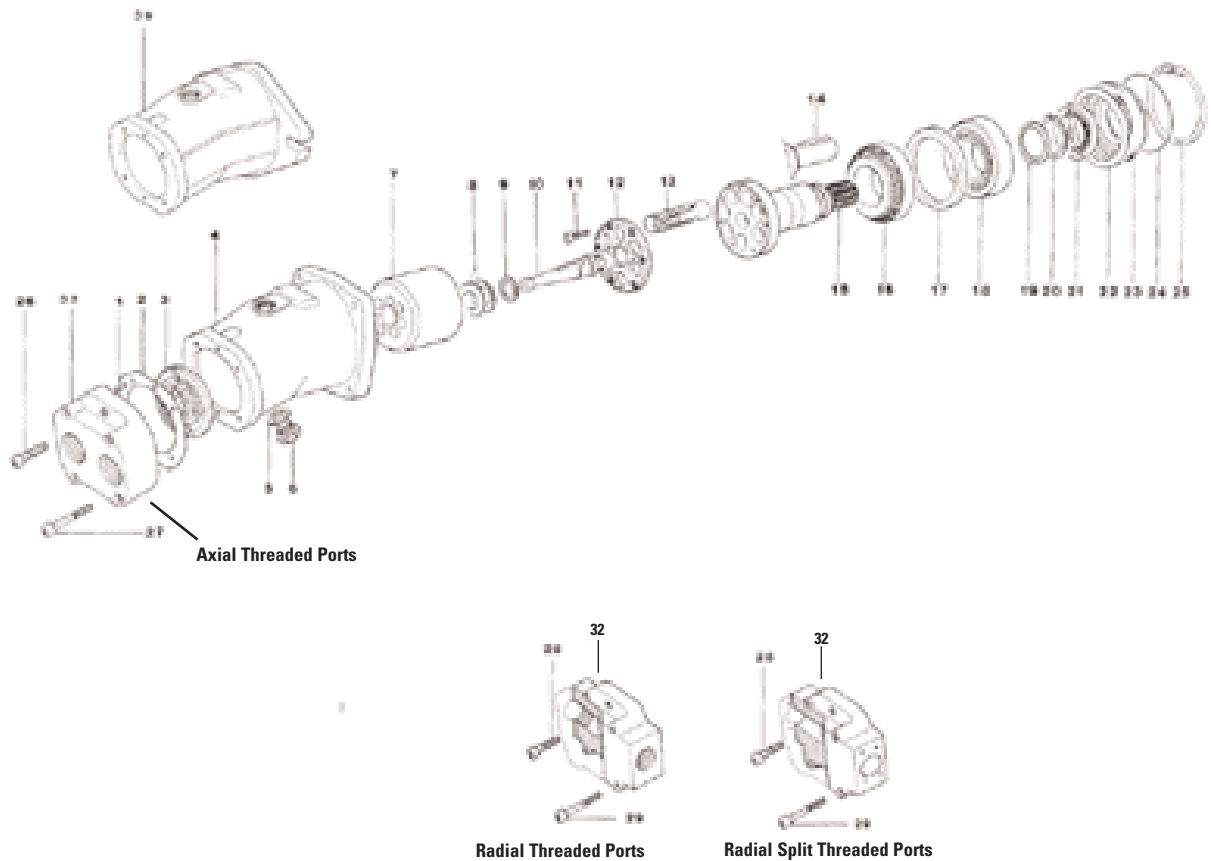

TABLE 2.0
BAF PARTS

BENT AXIS FIXED DISPLACEMENT MODEL PARTS

1.	Pin	22.	Shims
2.	Gasket	23.	Seal Cover
3.	Valve Plate	24.	O-Ring*
4.	Housing	25.	Circlip
5.	Washer	26.	Bolt
6.	Plug	27.	Bolt
7.	Cylinder Barrel	28.	Bolt
8.	Belleville Washers (As Required)	29.	Bolt
9.	Shims (As Required)	32.	End Cover
10.	Center Pivot		
11.	Bolt		
12.	Retaining Plate		
13.	Piston Assembly: Piston + Rod		
14.	Straight Keyed Shaft		
15.	Splined Shaft		
16.	Tapered Roller Bearing		
17.	Spacer		
18.	Ball Bearing		
19.	Spacer		
20.	Retaining Ring		
21.	Shaft Seal*		

* Included in seal kit

Parts

Pre-Load Spring

The system of pre-loading the cylinder barrel has been modified to improve performance and facilitate maintenance of BAV and BAF axial piston motors. The new design eliminates the Belleville spring and its substitutes a coil spring in the cylinder barrel.

This new design has different components from the Belleville spring design.

The new design includes:

- Cylinder barrel
- Central rod
- Valve plate

There is no interchangeability of components between the two designs. There is a gradual phase-in of the new design during 2004 & 2005.

1. Central rod
2. Cylinder barrel
3. Valve plate
4. Coil spring

Design Code B Change/timeline consists of the following:

DISPLACEMENT	DATES
55, 90, 108 cc/rev	2004
160, 225 cc/rev	2005

Belleville Spring Design

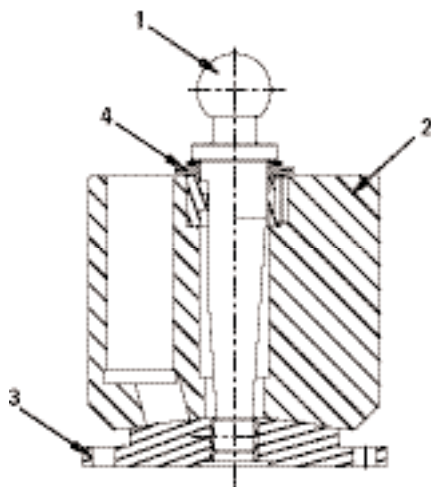

Design Code A

Coil Spring Design

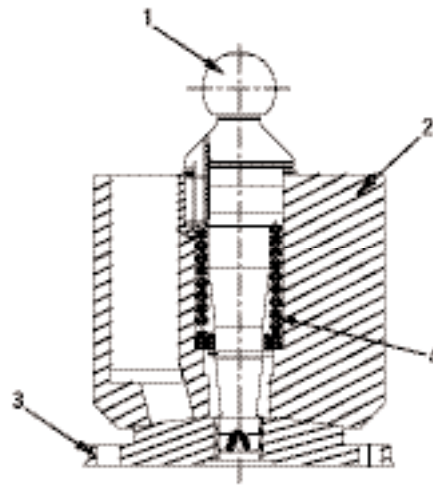

Design Code B

Parts

Seal Kits

TABLE 3.0 BAV SEAL KITS

9900280-xxx Includes: Shaft seal(21), gasket (1), o-ring(24), and motor control seals

9900281-xxx Includes: Items 1, 21, 24

DISPLACEMENT CC/REV	MOUNTING CONFIGURATION	MATERIAL STANDARD (NBR) BAV	MATERIAL VITON (FKM) BAV
55	Metric/SAE/Gearbox	9900280-001	9900280-002
	Metric/SAE/Gearbox	9900281-001	9900281-002
75*	Metric/SAE/Gearbox	9900280-003	9900280-004
	Metric/Gearbox	9900281-003	9900281-004
	SAE	9900281-005	9900281-006
108	Metric/SAE/Gearbox	9900280-005	9900280-006
	Metric/Gearbox	9900281-007	9900281-008
	SAE	9900281-009	9900281-010
161	Metric/SAE	9900280-007	9900280-008
	Metric/SAE	9900281-011	9900281-012
225	Metric/SAE	9900280-009	9900280-010
	Metric/SAE	9900281-013	9900281-014

*Note: For BAV75 motor with W40 Shaft, use only SAE kit.

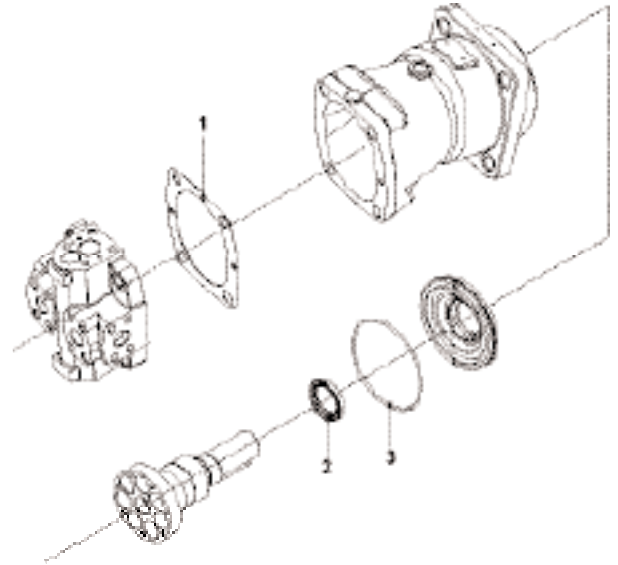
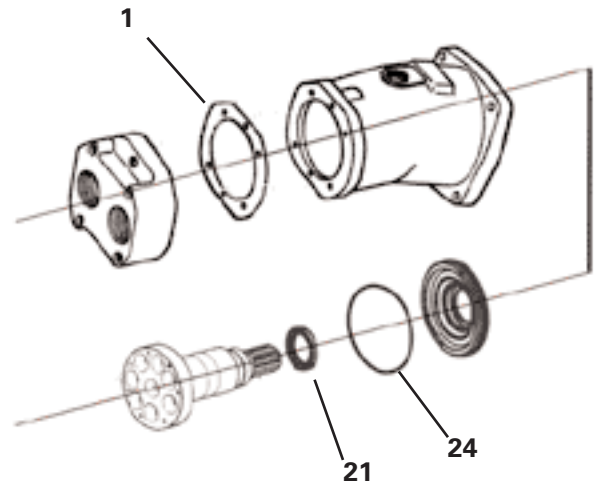

TABLE 4.0 BAF SEAL KITS

DISPLACEMENT CC/REV	MOUNTING CONFIGURATION	MATERIAL STANDARD (NBR) BAF	MATERIAL VITON (FKM) BAF
11	Metric/SAE	9900282-003	9900282-004
20, 30	Metric/SAE	9900282-005	9900282-006
30	Metric only	9900283-001	9900283-002
44, 55	Metric/SAE	9900282-007	9900282-008
	Gearbox	9900283-003	9900283-004
75	Metric	9900282-009	9900282-010
	SAE	9900282-011	9900282-012
	Gearbox	9900283-005	9900283-006
87, 108	Metric	9900282-013	9900282-014
87, 108	SAE	9900282-015	9900282-016
87,	Gearbox	9900283-007	9900283-008
108	Gearbox	9900283-009	9900283-010
161	Metric/SAE	9900282-017	9900282-018
225	Metric/SAE	9900282-019	9900282-020



Parts

Shaft & Bushing Kits

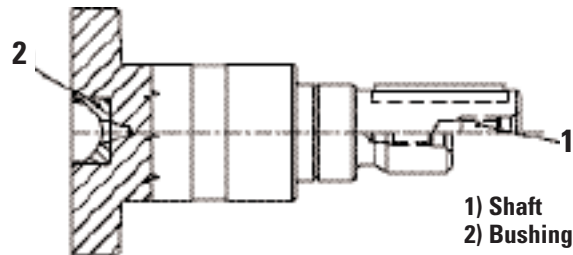

TABLE 5.0 SHAFT KITS

EATON KIT NUMBER	EATON PRODUCT CODE	EATON DISPLACEMENT CODE	EATON SHAFT CODE	SHAFT DESCRIPTION	TYPE
		Pos. 4,5,6	Pos. 8,9		
9900332-001	BAF	11	-20	14 Tooth w/ 20 splined shaft	Metric
9900332-002	BAF	11	-01	20mm Straight keyed shaft	Metric
9900332-003	BAF	020 & 030	-25	18 Tooth w/25 splined shaft	Metric
9900332-004	BAF	020 & 030	-02	25mm Straight keyed shaft	Metric
9900332-005	BAF / BAV	040, 044 & 055	-30	14 Tooth w/30 splined shaft	Metric
9900332-006	BAF / BAV	040, 044 & 055	-03	30mm Straight keyed shaft	Metric
9900332-007	BAF / BAV	75	-35	16 Tooth w/35 splined shaft	Metric
9900332-008	BAF / BAV	75	-04	35mm Straight keyed shaft	Metric
9900332-009	BAF / BAV	087 & 108	-40	18 Tooth w/40 splined shaft	Metric
9900332-010	BAF / BAV	087 & 108	-05	40mm Straight keyed shaft	Metric
9900332-011	BAF / BAV	161	-45	21 Tooth w/45 splined shaft	Metric
9900332-012	BAF / BAV	161	-06	45mm Straight keyed shaft	Metric
9900332-013	BAF / BAV	225	-50	24 Tooth w/50 splined shaft	Metric
9900332-014	BAF / BAV	225	-07	50mm Straight keyed shaft	Metric
9900332-015	BAF / BAV	020 & 030	-12	13 Tooth splined shaft	SAE
9900332-016	BAF / BAV	020 & 030	-08	7/8 Straight keyed shaft	SAE
9900332-017	BAF / BAV	040, 044 & 055	-14	14 Tooth splined shaft	SAE
9900332-018	BAF / BAV	040, 044 & 055	-09	1 1/4 Straight keyed shaft	SAE
9900332-019	BAF / BAV	75	-13	13 Tooth splined shaft	SAE
9900332-020	BAF / BAV	75	-11	1 3/4 Straight keyed shaft	SAE
9900332-021	BAF / BAV	087 & 108	-13	13 Tooth splined shaft	SAE
9900332-022	BAF / BAV	087 & 108	-11	1 3/4 Straight keyed shaft	SAE
9900332-023	BAF / BAV	161	-13	13 Tooth splined shaft	SAE
9900332-024	BAF / BAV	161	-11	1 3/4 Straight keyed shaft	SAE
9900332-025	BAF / BAV	225	-13	13 Tooth splined shaft	SAE
9900332-026	BAF / BAV	225	-11	1 3/4 Straight keyed shaft	SAE

Disassembly

When disassembling or assembling any Bent Axis piston motor we recommend you choose an ideal workplace. The work area must be clean and free of airborne contaminants.

Clean parts which have been disassembled, use clean solvents and appropriate tools which have been previously cleaned. Use new, clean and threadless rags to handle and dry parts. Remove the shaft seal following the procedure for your type of seal.

Note: Thoroughly clean the exterior of the unit and around stationary seal assembly before disassembly. Make sure all open ports are sealed.

Step 1

Mark housing and cover so that they may be matched up later during assembly.

NOTE: See page 5 for different end cover types.

Step 2

Remove the end cover bolts.

MOTOR	WRENCH SIZE (mm)
BAF 20/30	6
BAF 40/55	8
BAF 75	10
BAF 90/108	10
BAF 161	10
BAF 225	12

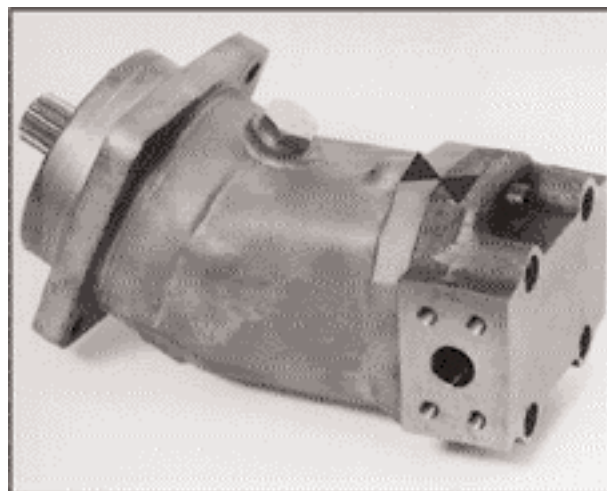

FIG 1.

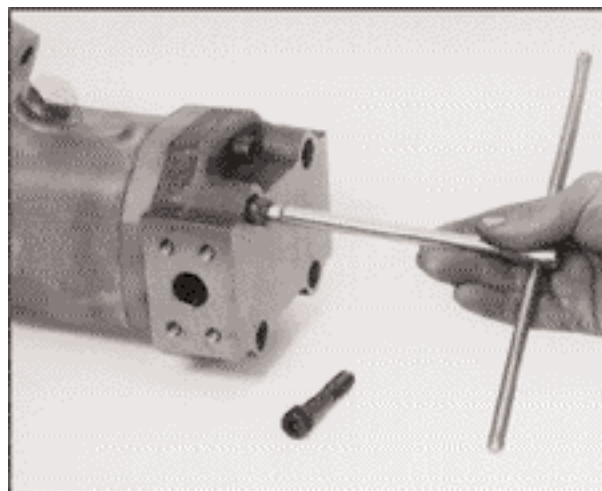

FIG 2.

Disassembly

Step 3

Remove the end cover, gasket and valve plate.



FIG 3.

Step 4

Remove retaining ring using appropriate pliers.

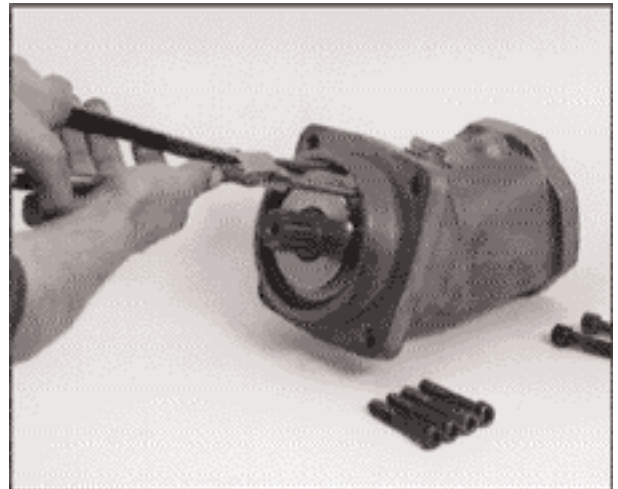

FIG 4.

Step 5

Pry off seal cover and shims with using two screwdrivers.

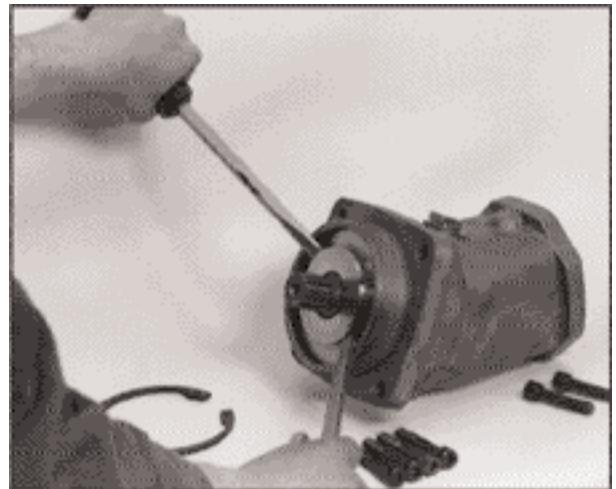

FIG 5.

Disassembly

Step 6

Assemble the motor on the shaft puller. Secure it with two screws on opposite ends of the square flange. Screw threaded pin A on the shaft.

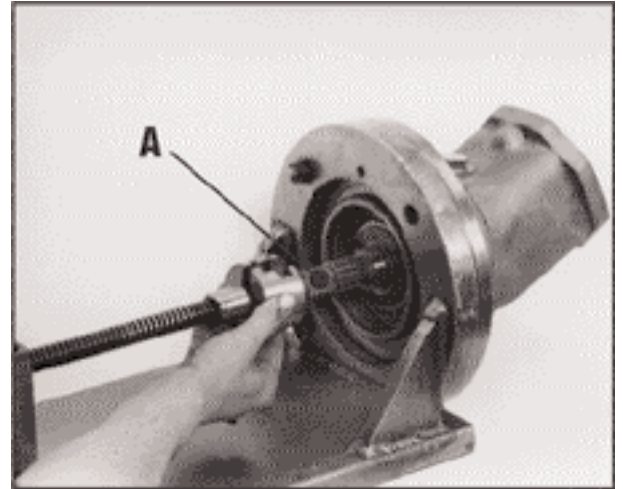

FIG 6.

Step 7

Remove rotating kit from the housing by turning the shaft puller handle. Use your other hand to guide the cylinder barrel during removal to avoid contact with the housing.

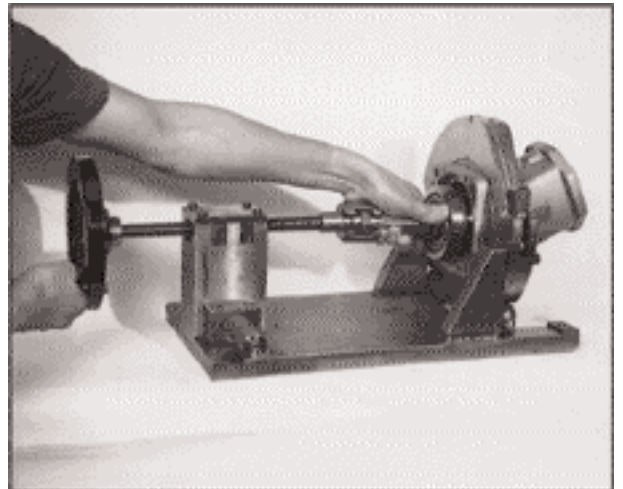

FIG 7.

Step 8

Mark cylinder barrel, shaft and retaining plate in a line with each other. This will be used as a match mark for alignment during the assembly process.

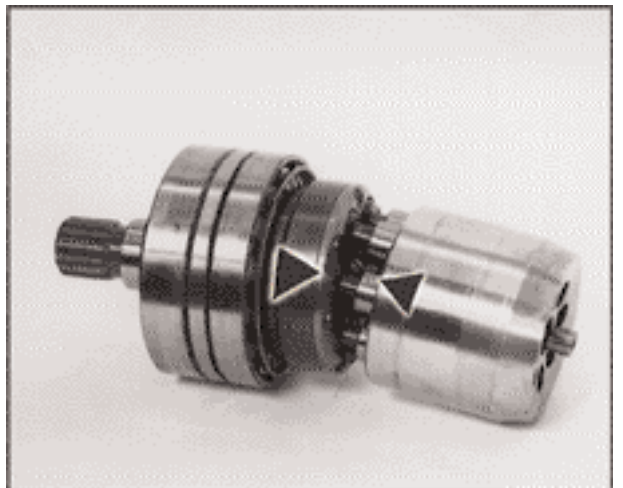

FIG 8.

Disassembly

Step 9

Remove cylinder barrel, Belleville washers and shims (as required).



FIG 9.

Step 10

Using an allen key, remove screws which attach the retaining plate.

MOTOR	WRENCH SIZE MM
BAF 20/30	5
BAF 44/55	4
BAF 75	5
BAF 90/108	5
BAF 161	5
BAF 225	6

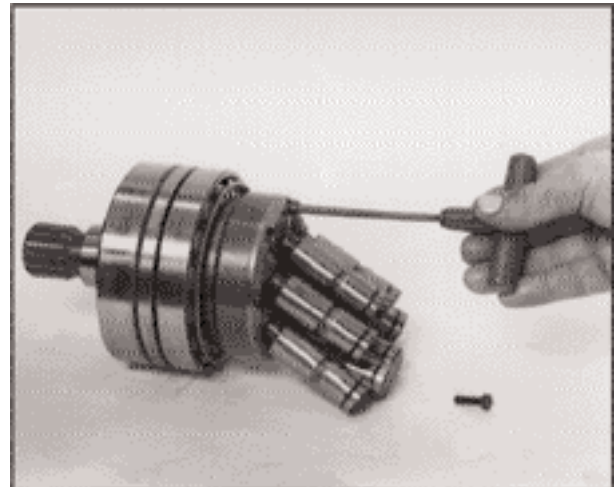

FIG 10.

Disassembly

Step 11

Remove retaining plate with pistons.



FIG 11.

Step 12

Use a permanent fine point pen to label the retaining plate and pistons with corresponding location numbers. This will ensure correct placement when they are reassembled. Carefully separate pistons, starting from the index mark on the retaining plate, and neatly place them down according to disassembly order.



FIG 12.

Step 13

With appropriate pliers, remove the retaining ring, spacer and shims. Once this is completed, remove bearings.

Once that you have disassembled the unit, check status of individual parts, carefully following the steps described in the next section.

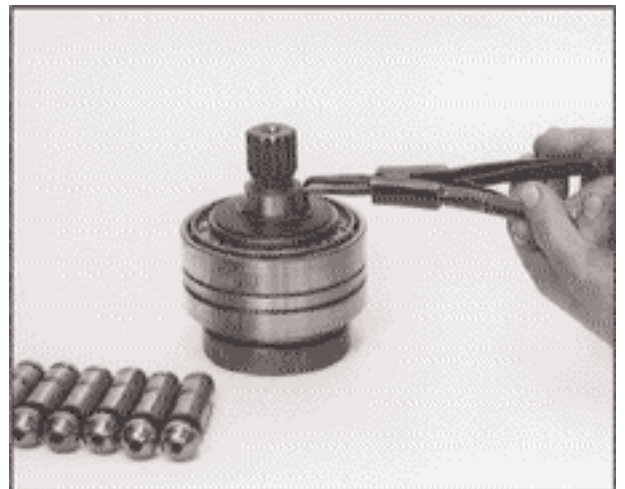

FIG 13.

Check Condition of Parts

Valve Plate

Check valve plate (item 3) protrusion out of the housing (see page 44, Critical Dimensions). If the distance measured is slightly less than normal requirements, replace Belleville washers. If, there is no protrusion or the valve plate is recessed in housing, this may indicate the following:

- A) Excessive wear of distributor spherical surfaces or cylinder barrel.
- B) Yield of Belleville washers. (Does not apply to coil spring design.)
- C) End Cover deformation.

Inspect other internal components for damage.

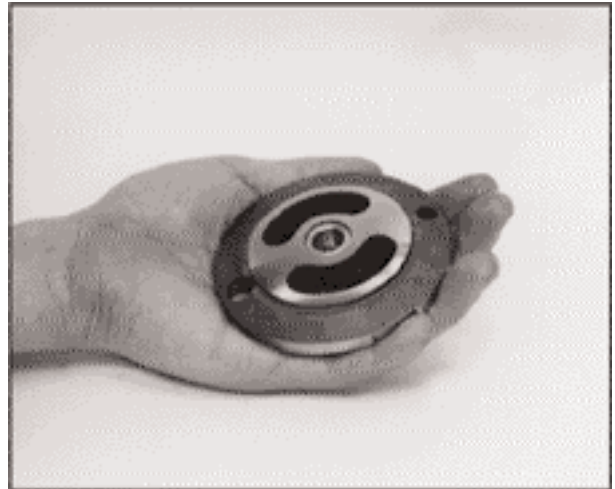

FIG 1.

Seal Cover

Remove O-ring and shaft seal from cover and check wear. Signs of excessive wear or seal extrusion may indicate excessive case pressure. (Pressure should not exceed 35 psi - 2.5 bar).

Note: Replace all seals when servicing motors.

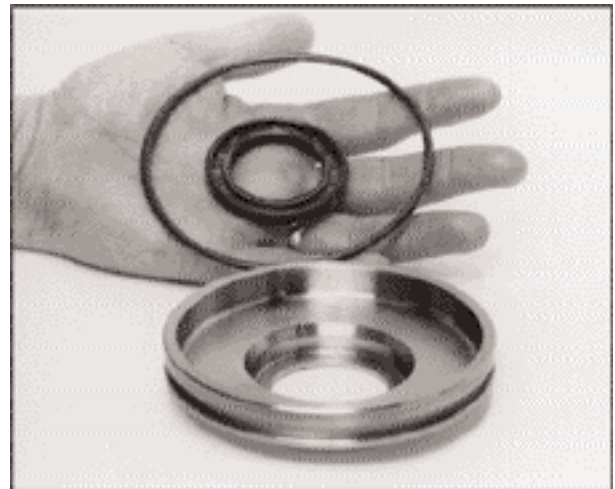

FIG 2.

Cylinder Barrel

Inspect Sealing face of cylinder barrel for raised edges, wear or smearing of material.



FIG 3.

Check Condition of Parts

Piston

Inspect spherical base of the pistons and their seats on the shaft, the piston surface and the piston bores surface.

TABLE 6.0 PISTON PARTS

DISPLACEMENT (CM ³)	DIM A(mm)	DIM B(mm)	DIM C(mm)	DIM D(mm)
20	16 ⁺⁰ / _{-0.005}	0.02 ÷ 0.10	0.80 ÷ 0.90	16 ⁺⁰ / _{-0.005}
30	16 ⁺⁰ / _{-0.005}	0.02 ÷ 0.10	0.80 ÷ 0.90	16 ⁺⁰ / _{-0.005}
40	20 ⁺⁰ / _{-0.020} / _{-0.025}	0.02 ÷ 0.10	1.00 ÷ 1.16	20 ⁺⁰ / _{-0.020} / _{-0.025}
55	20 ⁺⁰ / _{-0.020} / _{-0.025}	0.02 ÷ 0.10	1.00 ÷ 1.16	20 ⁺⁰ / _{-0.020} / _{-0.025}
75	22 ⁺⁰ / _{-0.005}	0.02 ÷ 0.10	0.29 ÷ 0.59	22 ⁺⁰ / _{-0.005}
90	25 ⁺⁰ / _{-0.005}	0.02 ÷ 0.10	0.51 ÷ 0.65	25 ⁺⁰ / _{-0.005}
108	25 ⁺⁰ / _{-0.005}	0.02 ÷ 0.10	0.51 ÷ 0.65	25 ⁺⁰ / _{-0.005}
160	28.7 ⁺⁰ / _{-0.005}	0.02 ÷ 0.08	0.96 ÷ 1.10	28.7 ⁺⁰ / _{-0.005}
226	32 ⁺⁰ / _{-0.020} / _{-0.025}	0.02 ÷ 0.10	1.38 ÷ 1.578	32 ⁺⁰ / _{-0.020} / _{-0.025}



FIG 4.

PART IDENTIFICATION

- A = Piston rod diameter
- B = Piston-rod axial end float
- C = Rod rotation (Max)
- D = Piston bore diameter

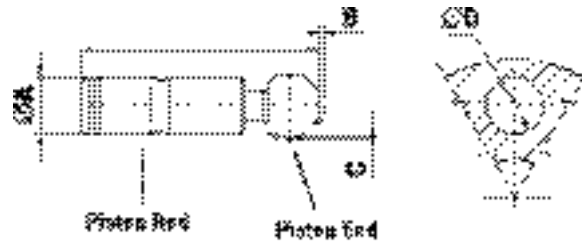

Bearings

Inspect bearings. Replace where there is excessive clearance or pitting on race. Check bearing pockets in housing for wear.



FIG 5.

Assembly

Step 1

Lubricate shaft with petroleum jelly, slip in bearing, spacer and bearing. Use appropriate tool and rubber mallet to drive into place.

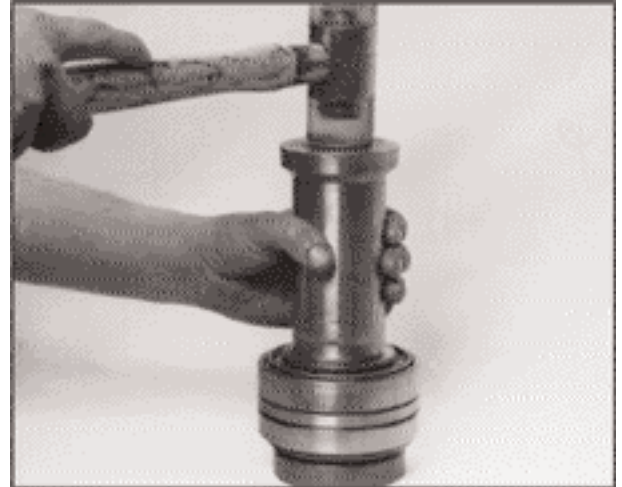

FIG 1.

Step 2

Assemble the spacer, the shims and the retaining ring. Ensure the bearings are free to rotate without any axial movement on the shaft. Add additional shims as required.

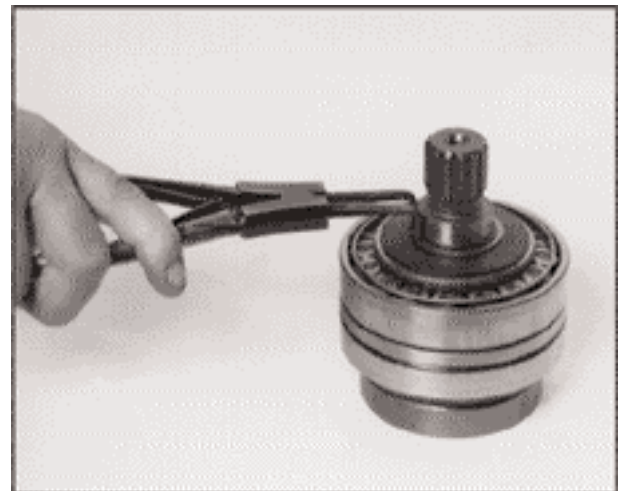

FIG 2.

Step 3

To ensure there is no axial movement, place a dial indicator on the outer bearing race. Axial movement should read between + 0.005 and 0.08 mm.

Note: Hold shaft stationary during measurement

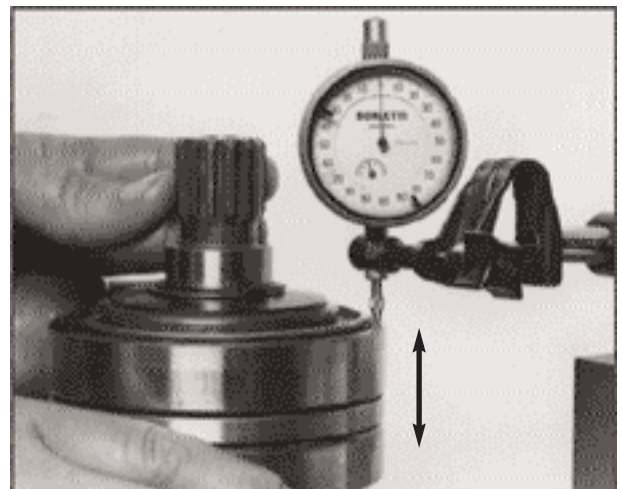

FIG 3.

Assembly

Step 4

Install seven pistons into the retaining plate using the corresponding numbered pockets for correct placement and original assembly order.



FIG 4.

Step 5

Secure pistons and retaining plate on shaft in original marked position. Pour two drops of Loctite 242 on every retaining plate screw.



FIG 5.

Step 6

Tighten screws on retaining plate to shaft assembly using allen key.



FIG 6.

Assembly

Step 7

Ensure the two-piece pistons can rotate and move freely in any direction.



FIG 7.

Step 8.

Install shims, Belleville washers (as required) and center pivot into cylinder barrel. Match up alignment marks created before disassembly.

Lubricate pistons and insert into cylinder barrel. Align Match marks created during disassembly.

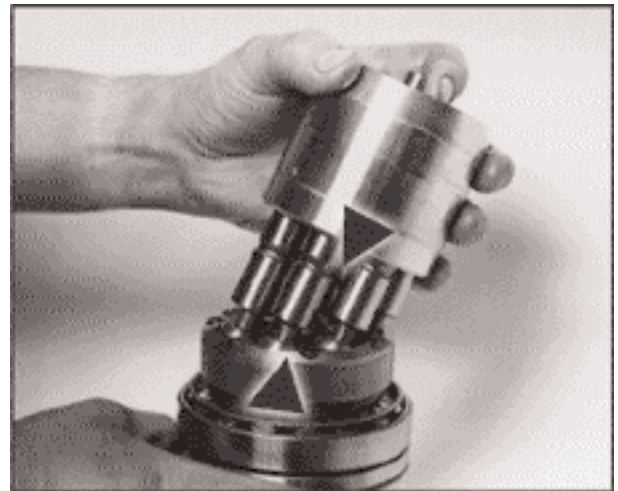

FIG 18.

Step 9.

Verify the cylinder barrel may pivot laterally as shown in figure 9.



FIG 9.

Assembly

Step 10

Secure housing in the bench vice and lubricate bearing seats with petroleum jelly.

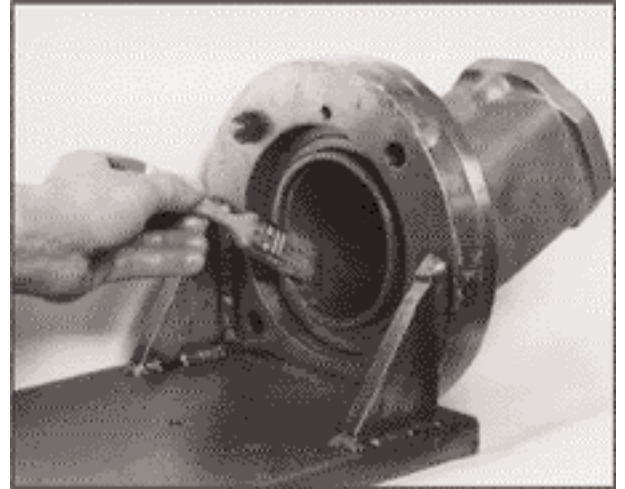

FIG 10.

Step 11

Insert the rotating kit into the housing, turning the handle gradually until it is fully seated.

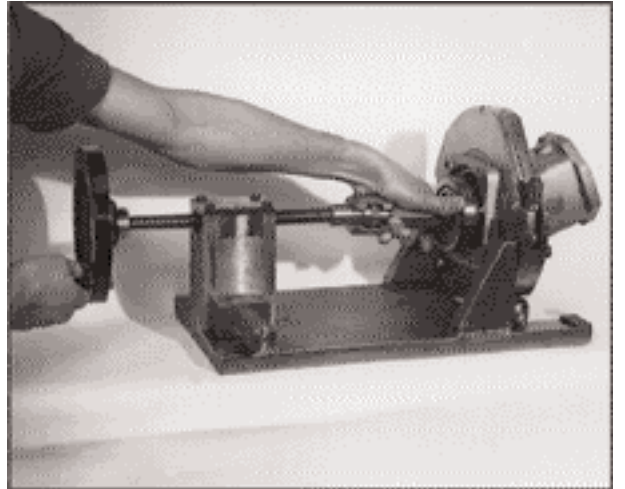

FIG 11.

Step 12

Assemble cover, shaft seal, o-ring and shims (see tables page 42). Then secure with the retaining ring.

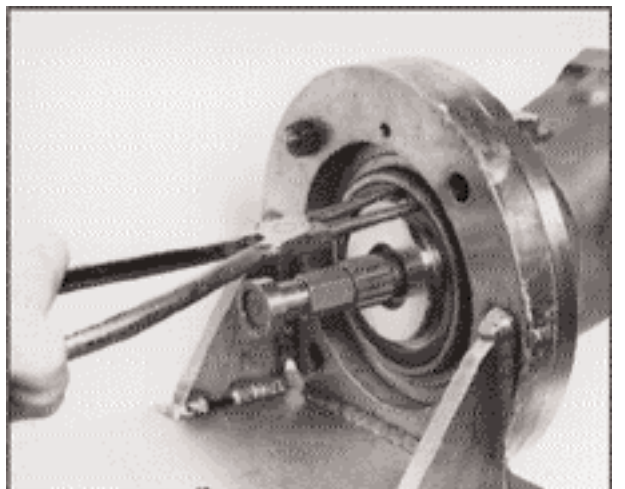

FIG 12.

Assembly

Step 13

Attach the shaft puller rod onto the shaft and pull the shaft bearing out against the retaining ring.

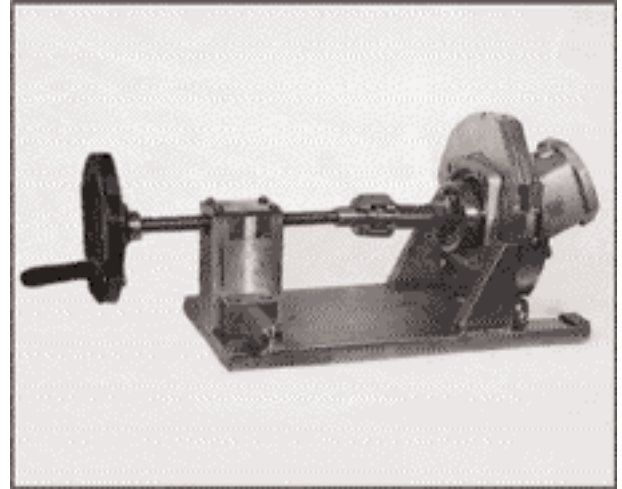

FIG 13.

Step 14

Lubricate the spherical surface of the valve plate, then assemble it with the cylinder barrel/housing. Verify the shaft can't turn freely in housing.

Note: Also make sure that the hole for pin 1 is set aligned to the vertical center line of the casing.

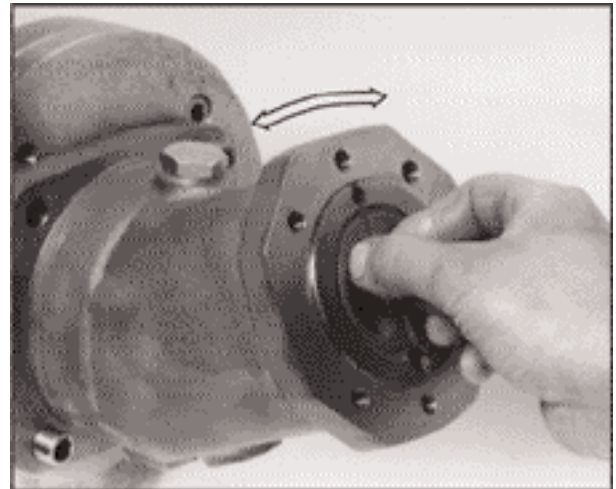
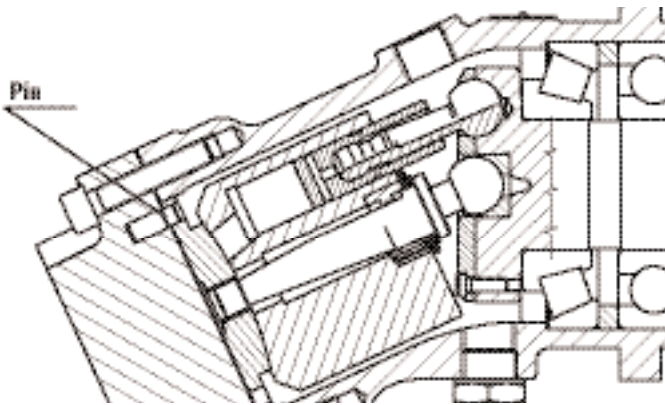

FIG 14.

Step 15

Check that valve plate sits slightly higher than housing. The distance measured between the two should be as follows (applies to Belleville spring design only).

DISPLACEMENT	DISTANCE (mm)
BAF 20/30	1.3 ±1.5
BAF 44/55	1.3 ±1.5
BAF 75	1.3 ±1.5
BAF 90/108	1.4 ±1.6
BAF 161	1.5 ±1.7
BAF 225	1.5 ±1.7

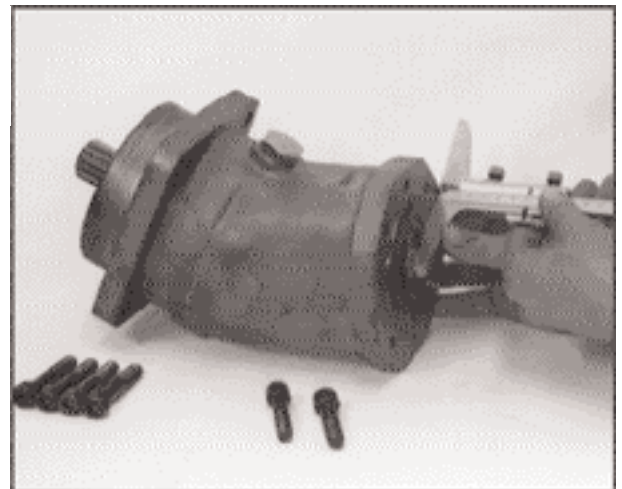

FIG 15.

Assembly

Step 16

Install gasket, assemble end cover and tighten screws and torque according to requirements in table shown below.

TABLE 7.0 BAF END COVER BOLT TIGHTENING TORQUE VALUES

BOLT	M8	M10	M12	M14
Torque (Nm)	2.5	5.0	8.5	13.5

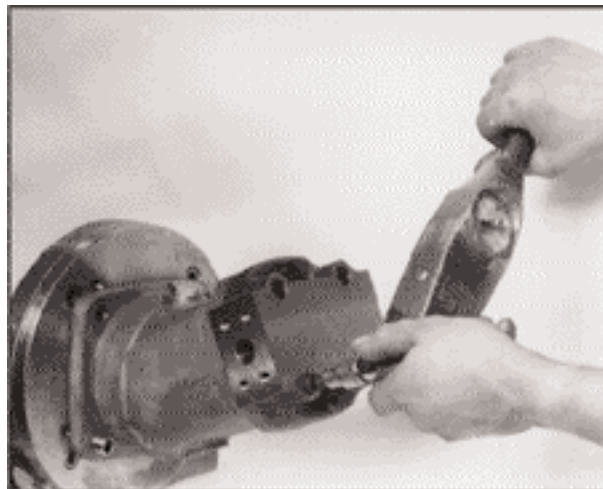

FIG 16.

TABLE 7.1 BAV MOTOR CONTROL BOLT TORQUE VALUES

POS.	BAV 55	BAV 75	BAV 108	BAV 161	BAV 225
Bolt 1	M 14x45 - 8.8 (12 N-m)	M 16x50 - 8.8 (18 N-m)	M 18x60 - 8.8 (26 N-m)	M 18x60 - 8.8 (26 N-m)	M 20x60 - 12.9 (40 N-m)
Bolt 2	-	-	-	M 10x35 - 8.8 (5 N-m)	M 10x35 - 8.8 (5 N-m)
Plug 3	G 1/8" - 8.8 (3 N-m)	G 1/8" - 8.8 (3 N-m)	G 1/8" - 8.8 (3 N-m)	G 1/8" - 8.8 (3 N-m)	G 1/8" - 8.8 (3 N-m)
Bolt 4	M 8x35 - 12.9 (4 N-m)	M 10x30 - 12.9 (7 N-m)	M 10x30 - 12.9 (7 N-m)	M 12x30 - 12.9 (12 N-m)	M 12x30 - 12.9 (12 N-m)
Bolt 5	M 10x35 - 8.8 (4 N-m)	M 12x40 - 8.8 (8 N-m)	M 12x40 - 8.8 (8 N-m)	M 14x45 - 8.8 (12 N-m)	M 14x45 - 8.8 (12 N-m)
Plug 6	G 1/4" - 8.8 (4 N-m)	G 1/4" - 8.8 (4 N-m)	G 1/4" - 8.8 (4 N-m)	G 1/4" - 8.8 (4 N-m)	G 1/4" - 8.8 (4 N-m)
Bolt 7	M 8x65 - 12.9 (4 N-m)	M 10x70 - 12.9 (7 N-m)	M 10x70 - 12.9 (7 N-m)	M 12x70 - 12.9 (12 N-m)	M 12x70 - 12.9 (12 N-m)
Bolt 8	M 8x16 - 45H (3.5* N-m)	M 8x16 - 45H (3.5* N-m)	M 8x16 - 45H (3.5* N-m)	M 8x16 - 45H (3.5* N-m)	M 8x16 - 45H (3.5* N-m)
Bolt 9	M 8x8 - 45H (2.5* N-m)	M 8x8 - 45H (2.5* N-m)	M 8x8 - 45H (2.5* N-m)	M 8x8 - 45H (2.5* N-m)	M 8x8 - 45H (2.5* N-m)

10 The tightening torque of caps, plugs and fittings must be comprised between 4 and 7 daNm

*Add Loctite 243

Installation Guidelines

NOTE: For dimensions and porting reference see dimensions section axial piston catalogue.

The following installation guidelines for Eaton Bent Axis piston motors are designed for standard components applied within catalog ratings. Observing these guidelines below will help ensure acceptable life of the motors.

1. Filling the Case

The case of bent axis piston motors must be pre-filled with hydraulic oil before the system is started for the first time.

Use the case drain connection at the highest point to ensure the case remains full at all times. See figure 1.

Caution: Starting the motor with little or no oil in the case causes immediate and permanent damage to the piston unit.

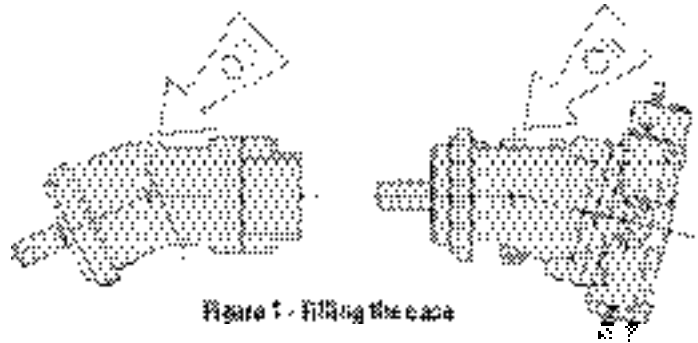

2. Connections

To reduce noise levels, flexible hoses are recommended (Main system pressure lines as well as case drain lines).

Case drain hoses should be as short as possible.

Minimize pressure drops due to couplings, elbows and differences in diameter.

Where non-flexible tubes are used, ensure that the pipes do not pull on the cover of the motor.

All hoses connected to tank (case drain lines) should be immersed at least 200 mm [8 in.] below the minimum oil level and at least 150 mm [6 in.] from the bottom of the tank.

Drive Shaft

Take special care to ensure that mechanical parts of the motor are coupled correctly. Ensure that the shaft and flange are lined up accurately to prevent additional loads on the shaft bearings. Flexible couplings should be used.

Caution: Incorrectly aligned parts significantly reduce the service life of the bearings.

Installation Guidelines

Installation position

Motors may be installed both above and below the level of the fluid in the tank, (lowest level of the oil when the system is operating). When motors are used in open circuit applications, the oil level is affected by the number and size of any hydraulic cylinders used in the system. For mobile installations it is important to take into account the slope of the ground and the effect of centrifugal forces on the oil level.

Installation above the tank

Particular care should be taken when installing units above the tank. Special case drain hoses must always be used to prevent the case from being siphoned out.

Always use the highest case drain port available and ensure that the line is designed such that the motor case remains full at all times.

It is recommended to position a pre-loaded check valve in the cased drain line (maximum pressure when open: 0.5 bar [8 psi]) to prevent oil from draining from the motor case when the system is not in use

The oil level of the units should be checked at regular intervals. It is essential to check the level if the system is out of service for extended periods of time, since the force of gravity causes oil to drain from the case.

Installation below the tank

Installation below the minimum level of the fluid (or immersed in fluid) does not create particular problems.

Gearbox mount motors should not be installed vertically with the shaft oriented upwards.

Flushing

If Bent Axis piston motors are to be installed with shaft turned upwards, or run at high oil temperature inside the tank (>50YC), or if units are used for a long operation time at high pressures (>250 bar), it is recommended to flush motor/pump bearings, by using oil at equal or lower temperature than the tank. Flush the bearings through Port E

System Start-up

Before starting system for the first time, fill system components with new and filtered oil. In addition, clean the reservoir and fill with the same type of oil. We recommend flushing the circuit. Verify that charge pressure is correct (closed circuits). Check reservoir level and top-off if necessary.

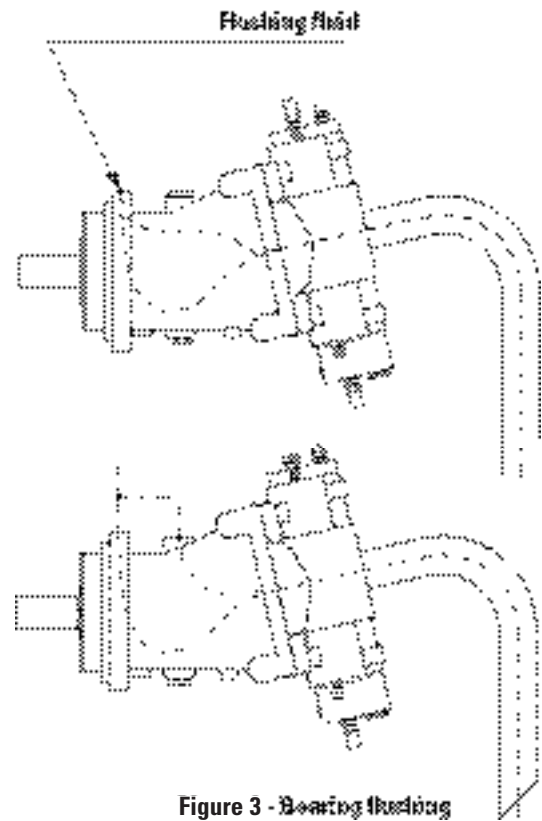
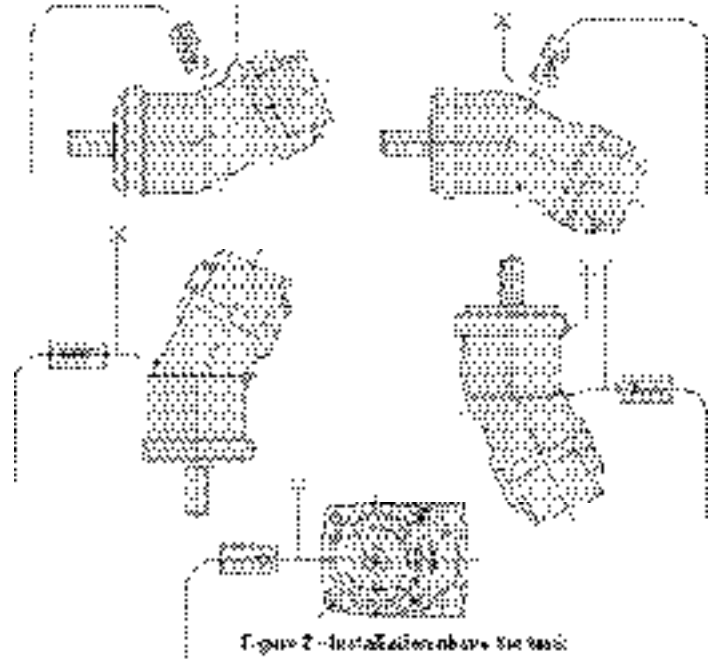

Controls

Technical Data

TABLE 8.0

**MAXIMUM DISPLACEMENT
PERFORMANCE SPECIFICATIONS**

Model	Vgmax [cm³/rev]	Qmax (*) [l/min]	Q drain (Max) [l/min]	η_v (Max)	N Target Speed at 250 bar
BAV 55	54.83	54.8	min 0.5 max 1.5	min 96%	2500 rpm
BAV 75	75.3	75.3	min 0.7 max 2	min 96%	2500 rpm
BAV108	107.5	107.5	min 1 max 2.7	min 96%	2500 rpm
BAV161	160.8	160.8	min 1.3 max 3.5	min 96%	2200 rpm
BAV 225	225.1	225.1	min 1.6 max 4.5	min 96%	1800 rpm

(*): 1000 rpm, 40 bar

**MINIMUM DISPLACEMENT
PERFORMANCE SPECIFICATIONS**

Model	Vgmin [cm³/rev]	Qmin (*) [l/min]	Q drain (Min) [l/min]	η_v (Min)	N Target Speed at 250 bar
BAV 55	15.8	15.8	min 0.5 max 1.5	min 94%	3000 rpm
BAV 75	21.7	21.7	min 0.7 max 2	min 94%	3000 rpm
BAV108	30.9	30.9	min 1 max 2.7	min 94%	3000 rpm
BAV161	46.2	46.2	min 1.3 max 3.5	min 94%	2500 rpm
BAV 225	64.8	64.8	min 1.6 max 4.5	min 94%	2500 rpm

(*): 1000 rpm, 40 bar

Table Definitions

Vgmax - Maximum Motor Displacement

Vgmin - Minimum Motor Displacement

Qmax - Test flow for setting maximum motor displacement

Qmin - Test flow for setting minimum motor displacement

Qdrain(max) - Case flow at maximum displacement, target speed, and pressure

Qdrain(min) - Case flow at minimum displacement, target speed, and pressure

η_v (max) - Volumetric efficiency at 250 bar and max displacement

η_v (min) - Volumetric efficiency at 250 bar and min displacement

N - Target Speed

Testing Procedures

BAV Controls

Motor setup for Testing "BAV" Variable Displacement Bent Axis Motors

1. Obtain the proper shaft coupling for the motor.
2. Clean the motor front flange of oil and/or dirt to facilitate evaluation of oil leakage from shaft seal after test.
3. Assemble the coupling on the motor shaft.
4. Mount the motor on the test stand.
5. Connect the high pressure lines to the main supply ports "A" and "B" of the motor.
6. Connect a case drain line to ports "C" or "D" port on motor housing (see table 8.0). Install a flow meter in case drain line to monitor.
7. Motor housing must be filled with oil before starting the test. Reference page 22 for instructions.
8. During testing should the system pressure fall below 40 bar, boost the control via Y1 port.
9. Initial run-in of the motor must be done at 500 rpm in both directions of rotation at pressures from 0 to 100 bar.
10. Continue with test procedure specific to appropriate control.

Before Proceeding with any control adjustments check the following:

1. Review/read through all instructions before starting the procedures.
2. Verify on order form desired displacement limitations of the motor.
3. Break-in of the motor must be done at 500 rpm, half in one rotation direction and half in the other, with pressure from 0 to 100 bar on all controls, except pressure response with adjustable hydraulic override (Biased to minimum displacement), a run-in pressure from 40 to 100 bar (X2 pressure 0 bar) is recommended.

Procedures for specific controls are located on the following pages:

	Page
EA & EC (Electric Proportional Control Biased to Maximum Displacement)27
EB & ED (Electric Proportional Control Biased to Minimum Displacement)28
HA Hydraulic Proportional Control (Biased to maximum displacement)29
HB Hydraulic Proportional Control (Biased to minimum displacement)30
H1 Hydraulic Two-Position Control (Biased to maximum displacement)31
H2 Hydraulic Two-Position Control (Biased to minimum displacement)32
M1 Manual Control (Biased to maximum displacement)33-34
M2 Manual Control (Biased to minimum displacement)35
PA Pressure Response Control (Biased to minimum displacement)36-37
PB Pressure Response Control with Adjustable Hydraulic Override (Biased to minimum displacement)38-39
E5" and "E6" Two-position electrical control with Pressure Response Control with Adjustable Hydraulic Override (Biased to maximum displacement)40-41

Testing Procedures

Control Options EA & EC
(Electric Proportional Control Biased to Maximum Displacement)

BAV Motor Adjustment & Port Locations

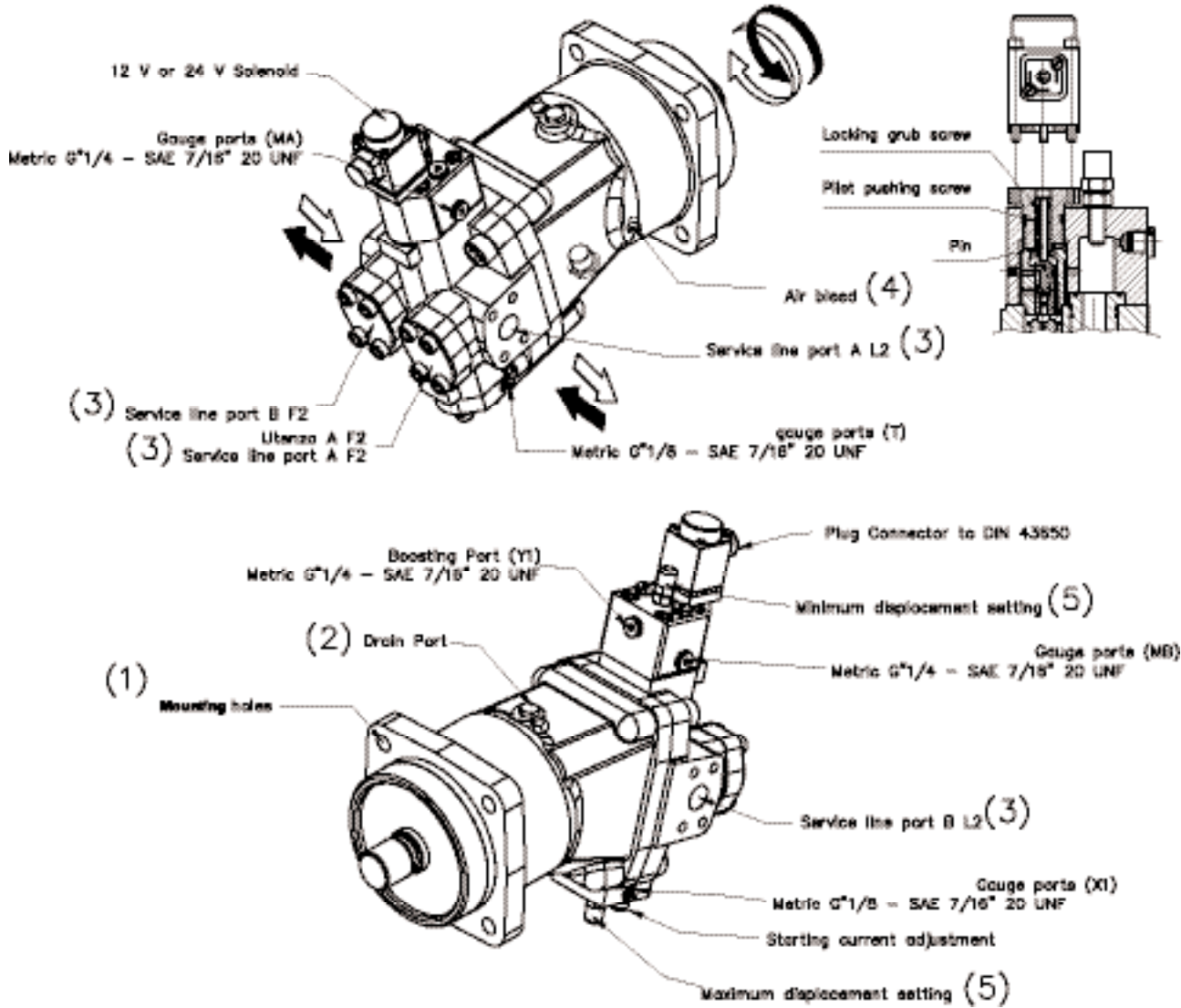

DISPLACEMENT	(1) Mounting Holes		(2) Case Drain Port		(3) High Pressure Ports		(4) Air Bleed Port		(5) MAX/MIN DISPLACEMENT SETTING SCREW VARIATION EACH SCREWTURN
	METRIC	SAE	METRIC	SAE	METRIC	SAE	METRIC	SAE	
BAV 55	Ø 13	Ø 14.3	G 1/2"	1"1/16-12 UN 2B	3/4" SAE 6000	3/4" SAE 6000	G 1/8"	7/16" - 20 UNF	1.4 cm ³ /rev
BAV 75	Ø 14	Ø 20.6	G 1/2"	1"1/16-12 UN 2B	1" SAE 6000	1" SAE 6000	G 1/8"	7/16" - 20 UNF	2 cm ³ /rev
BAV 108	Ø 17	Ø 20.6	G 1/2"	1"1/16-12 UN 2B	1" SAE 6000	1" SAE 6000	G 1/8"	7/16" - 20 UNF	2.6 cm ³ /rev
BAV 161	Ø 18	Ø 20.6	G 1/2"	1"1/16-12 UN 2B	1"1/4 SAE 6000	1"1/4 SAE 6000	G 1/8"	7/16" - 20 UNF	4 cm ³ /rev
BAV 225	Ø 22	Ø 20.6	G 3/4"	1"3/16-12 UN 2B	1"1/4 SAE 6000	1"1/4 SAE 6000	G 1/8"	7/16" - 20 UNF	5 cm ³ /rev

Testing Procedures

Control Options EA & EC (Electric Proportional Control Biased to Maximum Displacement)

1. Check/set MAXIMUM DISPLACEMENT (no load). Unscrew the maximum displacement adjustment screw. Unscrew the four solenoid screws and remove the solenoid and spacer from the control housing interface. Remove the pin and unscrew the lock nut. Unscrew the pilot-pushing screw until the motor is swiveled to maximum displacement. Set the flow rate according to the value reported on table 8.0 on page 24: the oil flow rate (in l/min.) must be set to the motor displacement numerical value (cm³/rev. (Example: Maximum 160 cm³/rev motor requires flow rate of 160 l/min). Adjust the displacement screw until the motor is running at 1000 rpm.
 2. Lock the adjustment screw with nut and locking nut (with their two washers).
 3. Check/set MINIMUM DISPLACEMENT (no load). Turn the pilot-pushing screw until the control swivels the motor to the maximum displacement. Set the oil flow rate according to the value reported on table 8.0 (see page 24), the numerical value of the oil flow rate (in l/min.) must be set to the motor displacement numerical value (in cm³/turn). (Example: Minimum displacement setting of 60 cm³/rev requires flow rate of 60 l/min). Adjust the displacement setting screw until the motor is running at 1000 rpm.
 4. Lock the adjustment screw with nut and locking nut (with their two washers).
 5. Turn the pilot-pushing screw CCW until the control starts to swivel the motor to the minimum displacement, then an additional one half turn CCW. Turn the locking grub screw on to lock the pilot-pushing screw.
 6. Insert the solenoid pin into its seat. Check that the distance between the pin end and the outer flat of the interface is 4.5 mm ± 0.2 mm. If this is not adjusted correctly, it will affect the control operation.
- WARNING:** The pin must be free to move into its seat. If not, disassemble the solenoid interface, remove the pin and bore the pin's seat. Once this has been done the pin should move freely. Reassemble the solenoid interface and the pin. Repeat setting procedure from point 1.
7. Mount the solenoid and the spacer on the interface. Tighten the screws at 0.5 daNm Max.
 8. Set the solenoid input current to 250 mA (BAV 55, 75, 108) or 300 mA (BAV 160, 226). Using the control current starting adjustment screw, turn it until the control starts to swivel the motor. Lock the control current adjustment screw with nut and locking nut.
 9. Solenoid input current range is 250 - 650 mA (BAV 55, 75, 108) or 300 - 700 mA (BAV 160, 226). Verify the control operation by starting at maximum displacement and biasing the motor toward minimum displacement and vice versa. Speed/displacement variation should be proportional to the input current and stepless. Verify control function two or three times by varying the input current at 0 bar working pressure and changing the direction of motor rotation. A small hysteresis is normal.
 10. Measure motor leakage and volumetric efficiencies at maximum displacement conditions. Use the procedure as per step 8 using a system pressure of 250 bar and motor input flows to achieve the target speed listed in table 8.0 (see page 24).
 11. Check the CASE DRAIN OIL FLOW RATE at MAX DISP. The acceptable values are listed in table 8.0 on page 24. This test must be done in both the directions of rotation. Use the higher case flow rate and record for comparison to specifications.
 12. Check the CASE DRAINAGE OIL FLOW RATE at MINIMUM DISP. Increase the input current until the control swivels the motor to minimum displacement. The acceptable value of case drain flow rates are reported on table 8.0 (see page 24). This test should also be done in both the directions of rotation. Use the higher case flow rates for comparison to specifications.
 13. Check the VOLUMETRIC EFFICIENCY (250 bar working pressure) at maximum and minimum displacement with the following formula:
$$\eta_v = \frac{Vg \cdot n}{Q \cdot 1000}$$

Vg = motor displacement (cm³/rev)
n = speed (rpm)
Q = flow (l/min)

The test results must not fall below the published data in table 8.0 on page 24.
 14. Check for oil leaks. Stop the motor.
 15. Record the motor test data as required.

Testing Procedures

Controls EB & ED (Electric Proportional Control Biased to Minimum Displacement)

1. Check/set MINIMUM DISPLACEMENT (no load). Unscrew the minimum displacement adjustment screw. Unscrew the four solenoid screws and remove the solenoid and spacer from the interface. Remove the pin and unscrew the locking nut. Unscrew the pilot-pushing screw until the motor is swiveled to the minimum displacement. Set the flow rate according to the value reported on table 8.0 (see page 24): the numerical value of the oil flow rate (in l/min.) must be set to the motor displacement numerical value (in cm³/turn). Adjust the displacement screw until the motor is running at 1000 rpm.
 2. Lock the adjustment screw with nut and locking nut (with their two washers).
 3. Check/set MAXIMUM DISPLACEMENT (no load). Turn the pilot-pushing screw until the control swivels the motor to the maximum displacement. Set the oil flow rate according to the value reported on table 8.0 on page 24: the numerical value of the oil flow rate (in l/min.) must be set to the motor displacement numerical value (in cm³/turn). Adjust the displacement setting screw until the motor is running at 1000 rpm.
 4. Lock the said adjustment screw with nut and cap nut (with their two washers).
 5. Turn the pilot-pushing screw until the control starts to swivel the motor to the maximum displacement, then unscrew it one half turn. Rotate the locking grub screw to lock the pilot-pushing screw.
 6. Insert the pin into its seat. Check that the distance between the pin's end and the outer flat of the interface is 4.5 mm ± 0.2 mm. Restore it to this measurement, as this would affect the control operation.
- WARNING:** The pin must be free to move in its seat; if this is not, disassemble the solenoid interface, remove the pin and bore the pin's seat. Once this has been done the pin should move freely. Reassemble the solenoid interface and pin. Repeat setting procedure from point 1.
7. Fit the solenoid on the interface. Tighten the screws with 0.5 daNm Max.
 8. Set solenoid input current to 250 mA (BAV 55, 75, 108) or 300 mA (H2V 160, 226). Turn the control current starting setting screw until the control starts to swivel the motor. Lock the control current adjustment screw with nut and locking nut.
 9. Solenoid input current range is 250 - 650 mA (H2V 55, 75, 108) or 300 - 700 mA (H2V 160, 226). Check the control operation, starting from minimum displacement towards the maximum displacement and vice versa. This variation should be proportional to the input current and step less. Check the control's operation two or three times, varying the input current both increasing and decreasing it, with 0 bar working pressure and changing the direction of rotation. A small hysteresis is normal.
 10. Using an appropriate solvent, clean oil traces from the motor. Check for oil leaks during the following high pressure test.
 11. Measure motor leakage and volumetric efficiencies at maximum displacement conditions. Use the procedure as per step 9 using a system pressure of 250 bar and motor input flows to achieve the target speed listed in table 8.0 (see page 24).
 12. Check the DRAINAGE FLOW RATE at MAXIMUM DISP. The acceptable value is reported on table 8.0. This test must be done in both rotation directions. Report the highest flow rate in each direction on the test form.
 13. Check the DRAINAGE FLOW RATE at MINIMUM DISP. 250 bar, 3000 rpm. Increase the input current until the control swivels the motor to the maximum displacement. The acceptable value of drainage flow rates is reported on table 8.0, (see page 24). This test must be done in both the directions of rotation. Report the highest flow rate in each direction on the test form.
 14. Check the VOLUMETRIC EFFICIENCY (250 bar working pressure) at maximum and minimum displacement with the following formula:

$$\eta_v = \frac{Vg \cdot n}{Q \cdot 1000}$$

Vg = motor displacement (cm³/rev)

n = speed (rpm)

Q = flow (l/min)

The obtained data must not fall below the data in table 8.0 on page 24.

15. Check for oil leaks. Stop the motor.
16. Fill the motor test form with the required data.

Testing Procedures

Control Option HA Hydraulic Proportional Control (Biased to Maximum Displacement)

1. Increase the motor working pressure to at least 40 bar.
2. Check/set MAXIMUM DISPLACEMENT (working pressure at least 40 bar). Unscrew the control starting adjustment screw. Set the X2 port piloting pressure at 0 bar. Set the numerical value of the input flow rate (in l/min.) same as the motor displacement numerical value (in cm³/rev) (see table 8.0 on page 24). Adjust the displacement screw until the motor is running at 1000 rpm.
3. Lock the adjustment screw with nut and locking nut (with their two washers).
4. Check/set MINIMUM DISPLACEMENT (working pressure at 40 bar). Put to 8 – 9 bar the X2 port piloting pressure. Turn the control starting adjustment screw until the control swivels the motor to the minimum displacement. Unscrew 1/4-1/2 turn. Lock the adjustment screw with nut and cap nut (with their two washers).
5. Increase the X2 port piloting pressure until the control swivels the motor to the minimum displacement. Set the oil flow rate according to the value reported on table 8.0 (see page 24). Adjust the minimum displacement setting screw until the motor is running at 1000 rpm. The numerical value of the oil flow rate (in l/min.) must be set to the motor displacement numerical value (in cm³/rev). The minimum displacement adjustment screw must then be adjusted until the motor is running at 1000 rpm.
6. Lock the adjustment screw with nut and cap nut (with their two washers).
7. By varying the X2 port piloting pressure, check the maximum and minimum displacement just set. Any difference with the expected values must be corrected repeating the procedure from point 4 to point 7.
8. Check the HYDRAULIC PILOTING STARTING AND ENDING PRESSURES. The standard setting field is 6 - 18 bar. The gap between minimum and maximum piloting pressure must not be less than 10 bar. Check the control stability with intermediate hydraulic piloting pressures. Check that the control can always reach the pre-set maximum and minimum displacements. The hydraulic piloting starting and ending pressures must be recorded on test form.
9. Using an appropriate solvent, check for oil leaks and clean the motor during the following high pressure test.
10. Measure motor leakage and volumetric efficiencies at maximum displacement conditions. Use the procedure as per step 8 using a system pressure of 250 bar and motor input flows to achieve the target speed listed in table 8.0 (see page 24).
11. Check the DRAIN FLOW RATE at MAXIMUM DISP. The acceptable value is reported on table 8.0. This test must be done in both rotation directions. Report the highest flow rate in each direction on the test form.
12. Check the DRAIN FLOW RATE at MINIMUM DISP. Increase the piloting pressure on X2 port until the control swivels the motor to the minimum displacement. The acceptable value is reported on table 8.0, (see page 24). This test must be done in both rotation directions. Report the highest flow rate in each direction on the test form.
13. Check the VOLUMETRIC EFFICIENCY (250 bar working pressure) at maximum and minimum displacement with the following formula:
$$\eta_v = \frac{Vg \cdot n}{Q \cdot 1000}$$

Vg = motor displacement (cm³/rev)
n = speed (rpm)
Q = flow (l/min)

The obtained data must not fall below the data in table 8.0 on page 24.
14. Check for oil leaks. Stop the motor.
15. Fill the motor test form with the required data.

Testing Procedures

Control Option HB

Hydraulic Proportional Control (Biased to Minimum Displacement)

1. Increase the motor working pressure to at least 40 bar.
2. Check/set MINIMUM DISPLACEMENT (Working pressure at least 40 bar). Unscrew the control starting adjustment screw. Set the X2 port piloting pressure to 0 bar. Set the numerical value of the input flow rate (in l/min.) same as the motor displacement numerical value (in cm³/rev) (see table 8.0 on page 24). Adjust the displacement screw until the motor is running at 1000 rpm.
3. Lock the adjustment screw with nut and cap nut (with their two washers).
4. Check/set MAXIMUM DISPLACEMENT (working pressure at least 40 bar). Set to 8 – 9 bar the X2 port piloting pressure. Turn the control starting adjustment screw until the control swivels the motor to the minimum displacement. Unscrew starting adjustment screw 1/4-1/2 turn. Lock the adjustment screw with nut and cap nut (with their two washers).
5. Increase the X2 port piloting pressure until the control swivels the pump to the maximum displacement. Set the input flow rate according to the value reported on table 8.0 (see page 24): Adjust the maximum displacement setting screw until the motor is running at 1000 rpm. The numerical value of the input flow rate (in l/min.) must be set to the motor displacement numerical value (in cm³/rev). The maximum displacement adjustment screw must then be adjusted until the motor is running at 1000 rpm.
6. Lock the adjustment screw with nut and cap nut (with their two washers).
7. By varying the X2 port piloting pressure, check the maximum and minimum displacement just set. Any difference with the expected values must be corrected repeating the procedure from point 4 to point 7.
8. Check the HYDRAULIC PILOTING STARTING AND ENDING PRESSURES. Check the control starting and ending pressure. Standard control pressure is 6 - 18 bar. The gap between minimum and maximum necessary piloting pressure must not be less than 10 bar. Check the control stability with intermediate hydraulic piloting pressures. Check that the control can always reach the pre-set maximum and minimum displacements. The hydraulic piloting starting and ending pressures must be recorded on test form.
9. Using an appropriate solvent, check for oil leaks and clean the motor during the following high pressure test.
10. Measure motor leakage and volumetric efficiencies at

maximum displacement conditions. Use the procedure as per step 8 using a system pressure of 250 bar and motor input flows to achieve the target speed listed in table 8.0 (see page 24).

11. Check the DRAINAGE FLOW RATE at MINIMUM DISP. The acceptable value is reported on table 8.0 (see page 24). This test must be done in both rotation directions. Report the highest flow rate in each direction on the test form.
12. Check the DRAIN FLOW RATE at MAXIMUM DISP. Increase the piloting pressure until the control swivels the motor to the maximum displacement. The acceptable value of drain flow rates is reported on table 8.0. This test must be done in both rotation directions. Report the highest flow rate in each direction on the test form.
13. Check the VOLUMETRIC EFFICIENCY (250 bar working pressure) at maximum and minimum displacement with the following formula:

$$\eta_v = \frac{Vg \cdot n}{Q \cdot 1000}$$

Vg = motor geometrical displacement (cm³/giro)
n = speed (rpm)
Q = flow (l/min)

The obtained data must not fall below the data in table 8.0 (see page 24).

14. Check for oil leaks. Stop the motor.
15. Fill the motor test form with the required data.

End test

1. Open the lower drainage port S on the motor casing.
2. Remove the motor from the test bench.
3. Check for oil leaks from the front cover and the shaft seal.

Testing Procedures

Control Option H1

Hydraulic Two-Position Control

(Biased to Maximum Displacement)

1. Check/set MAXIMUM DISPLACEMENT (no load). No piloting pressure on X2 (Motor in maximum displacement). Set the flow rate according to the value reported on table 8.0 (see page 24): the numerical value of the oil flow rate (in l/min.) must be set to the motor displacement numerical value (in cm³/turn). Adjust the displacement screw until the motor is running at 1000 rpm.
2. Lock the adjustment screw with nut and locking nut (with their two washers).
3. Check/set MINIMUM DISPLACEMENT (no load). Set X2 port pressure at 30 bar (Motor in minimum displacement). Set the oil flow rate according to the value reported on table 8.0 (see page 24): the numerical value of the oil flow rate (in l/min.) must be set to the motor displacement numerical value (in cm³/turn). Adjust the displacement setting screw until the motor is running at 1000 rpm.
4. Lock the adjustment screw with nut and locking nut (with their two washers).
5. Minimum control piloting pressure setting. Set piloting pressure on X2 port at 15 bar. Turn the control starting screw, turn it until the control swivels the motor. Lock the screw into position with nut and locking nut.
6. With 0 bar working pressure, check that the control change from minimum to maximum displacement and vice-versa when the piloting pressure X2 is switched. This procedure must be done in both the directions of rotation of the motor.
7. Using an appropriate solvent, clean oil traces from the motor. Check for any oil leaks during the following high pressure test.
8. Measure motor leakage and volumetric efficiencies at maximum displacement conditions. Use the procedure as per step 6 using a system pressure of 250 bar and motor input flows to achieve the target speed listed in table 8.0 (see page 24).
9. Check the DRAINAGE FLOW RATE at MAX DISP. Acceptable value is reported on table 8.0 (see page 24). This test must be done in both rotation directions. Report the highest flow rate in each direction on the test form.
10. Check the DRAINAGE FLOW RATE at MIN DISP. To feed X2 port until the control swivels the motor to the minimum displacement. Acceptable value of drainage flow rates is reported on table 8.0 (see page 24). This test must be done in both rotation directions. Report the highest flow rate in each direction on the test form.
11. Check the VOLUMETRIC EFFICIENCY (250 bar working pressure) at maximum and minimum displacement with the following formula:
$$\eta_v = \frac{V_g \cdot n}{Q \cdot 1000}$$

V_g = motor displacement (cm³/rev)
n = speed (rpm)
Q = flow (l/min)

The obtained data must not fall below the data in table 8.0, on page 24.
12. Check for oil leaks. Stop the motor.
13. Fill the motor test form with the required data.

Testing Procedures

Control Option H2

Hydraulic Two-Position Control (Biased to Minimum Displacement)

1. Check/set MINIMUM DISPLACEMENT (no load). No Piloting pressure on X2 (Motor in minimum displacement). Set the flow rate according to the value reported on table 8.0 (see page 24): the numerical value of the oil flow rate (in l/min.) must be set to the motor displacement numerical value (in cm³/turn). Adjust the displacement screw until the motor is running at 1000 rpm.
2. Lock the adjustment screw with nut and locking nut (with their two washers).
3. Check/set MAXIMUM DISPLACEMENT (no load). Set X2 port piloting pressure to 30 bar (Motor in maximum displacement). Set the oil flow rate according to the value reported on table 8.0 (see page 24): the numerical value of the oil flow rate (in l/min.) must be set to the motor displacement numerical value (in cm³/turn). Adjust the displacement setting screw until the motor is running at 1000 rpm.
4. Lock the adjustment screw with nut and cap nut (with their two washers).
5. Minimum control piloting pressure setting. Set X2 piloting pressure to 15 bar. Turn the control starting screw, until the control swivels the motor. Lock the screw into position with nut and locking nut.
6. With 0 bar working pressure, check that the control change from minimum to maximum displacement and vice-versa when the piloting pressure X2 is switched. This procedure must be done in both the directions of rotation of the motor.
7. Using an appropriate solvent, clean the motor and check for oil leaks during the following high pressure test.
8. Measure motor leakage and volumetric efficiencies at maximum displacement conditions. Use the procedure as per step 6 using a system pressure of 250 bar and motor input flows to achieve the target speed listed in table 8.0 (see page 24).

9. Check the DRAINAGE FLOW RATE at MIN DISP. The acceptable value is reported on table 8.0. This test must be done in both rotation directions. Report the highest flow rate in each direction on the test form.
10. Check the DRAINAGE FLOW RATE at MAX DISP. To feed X2 port until the control swivels the motor to the maximum displacement. Acceptable value of drainage flow rates is reported on table 8.0 (page 24). This test must be done in both the directions of rotation. Report the highest flow rate in each direction on the test form.
11. Check the VOLUMETRIC EFFICIENCY (250 bar working pressure) at maximum and minimum displacement with the following formula:

$$\eta_v = \frac{Vg \cdot n}{Q \cdot 1000}$$

Vg = motor displacement (cm³/rev)

n = speed (rpm)

Q = flow (l/min)

The obtained data must not fall below the data in table 8.0 on page 24.

12. Check for oil leaks. Stop the motor.
13. Fill the motor test form with the required data.

End test

1. Open the lower drainage port S on the motor casing.
2. Remove the motor from the test bench.
3. Check for oil leaks from the front cover and the shaft seal.

Testing Procedures

Control Option “M1” Manual Control (Biased to Maximum Displacement)

Control Option “M2” Manual Control (Biased to Minimum Displacement)

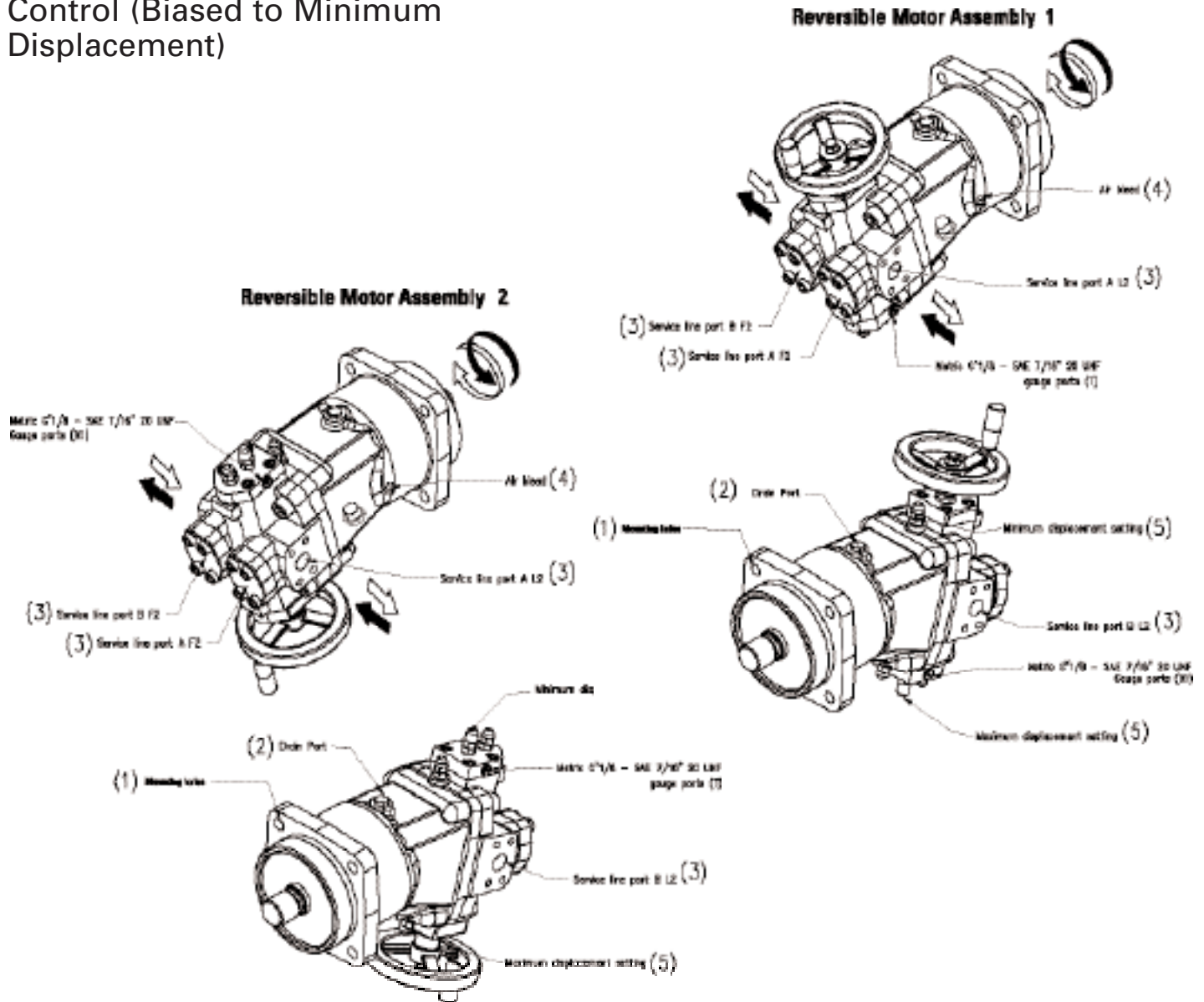

DISPLACEMENT	(1) Mounting Holes		(2) Case Drain Port		(3) High Pressure Ports		(4) Air Bleed Port		(5) MAX/MIN DISPLACEMENT SETTING SCREW VARIATION EACH SCREW TURN
	METRIC	SAE	METRIC	SAE	METRIC	SAE	METRIC	SAE	
BAV 55	Ø 13	Ø 14.3	G 1/2"	1"1/16-12 UN 2B	3/4" SAE 6000	3/4" SAE 6000	G 1/8"	7/16" - 20 UNF	1.4 cm ³ /rev
BAV 75	Ø 14	Ø 20.6	G 1/2"	1"1/16-12 UN 2B	1" SAE 6000	1" SAE 6000	G 1/8"	7/16" - 20 UNF	2 cm ³ /rev
BAV 108	Ø 17	Ø 20.6	G 1/2"	1"1/16-12 UN 2B	1" SAE 6000	1" SAE 6000	G 1/8"	7/16" - 20 UNF	2.6 cm ³ /rev
BAV 161	Ø 18	Ø 20.6	G 1/2"	1"1/16-12 UN 2B	1"1/4 SAE 6000	1"1/4 SAE 6000	G 1/8"	7/16" - 20 UNF	4 cm ³ /rev
BAV 225	Ø 22	Ø 20.6	G 3/4"	1"3/16-12 UN 2B	1"1/4 SAE 6000	1"1/4 SAE 6000	G 1/8"	7/16" - 20 UNF	5 cm ³ /rev

Testing Procedures

Control Option M1

Manual Control (Biased to Maximum Displacement)

1. Check/set MAXIMUM DISPLACEMENT (motor unloaded). Turn the hand wheel until the motor is at the maximum displacement. Set the flow rate according to the value reported on table 8.0 (see page 24): the numerical value of the oil flow rate (in l/min.) must be set to the motor displacement numerical value (in cm³/turn). Turn the maximum displacement setting screw until the motor turns at 1000 rpm.
2. Lock the adjustment screw with nut and locking nut (with their two washers).
3. Check/set MINIMUM DISPLACEMENT (motor unloaded). Turn the hand wheel until the motor is at the minimum displacement. Set the flow rate according to the value reported on table 8.0 (see page 24): the numerical value of the oil flow rate (in l/min.) must be set to the motor displacement numerical value (in cm³/turn). Turn the minimum displacement setting screw until the motor turns at 1000 rpm.
4. Lock the adjustment screw with nut and locking nut (with their two washers).
5. With motor unloaded, check that the hand wheel control changes the displacement motor from maximum displacement to minimum displacement and vice-versa. This procedure must be done in both the directions of rotation of the motor.
6. Using an appropriate solvent, check for oil leaks and clean the motor during the following high pressure test.
7. Measure motor leakage and volumetric efficiencies at maximum displacement conditions. Use the procedure as per step 5 using a system pressure of 250 bar and motor input flows to achieve the target speed listed in table 8.0 (see page 24).
8. Check the DRAINAGE FLOW RATE at MAXIMUM DISPLACEMENT. Turn the hand wheel until the motor is at maximum displacement. Acceptable value is reported on table 8.0 (see page 24). This test must be done in both rotation directions. Report the highest flow rate in each direction on the test form.
9. Check the DRAINAGE FLOW RATE at MINIMUM DISPLACEMENT. Turn the hand wheel until the motor is at minimum displacement. Acceptable value is reported on table 8.0 (see page 24). This test must be done in both rotation directions. Report the highest flow rate in each direction on the test form.
10. Check the VOLUMETRIC EFFICIENCY (250 bar working pressure) at maximum and minimum displacement with the following formula:
$$\eta_v = \frac{Vg \cdot n}{Q \cdot 1000}$$

Vg = motor displacement (cm³/rev)
n = speed (rpm)
Q = flow (l/min)

The obtained data must not fall below the data in table 8.0 (see page 24).
11. Check for any oil leaks. Stop the motor.
12. Fill the motor test form with the required data.

Testing Procedures

Control Option M2

Manual Control (Biased to Minimum Displacement)

1. Check/set MINIMUM DISPLACEMENT (motor unloaded). Turn the hand wheel until the motor is at the minimum displacement. Set the flow rate according to the value reported on table 8.0 (see page 24): the numerical value of the oil flow rate (in l/min.) must be set to the motor displacement numerical value (in cm³/turn). Turn the minimum displacement setting screw until the motor turns at 1000 rpm.
2. Lock the adjustment screw with nut and locking nut (with their two washers).
3. Check/set MAXIMUM DISPLACEMENT (motor unloaded). Turn the hand wheel until the motor is at the maximum displacement. Set the flow rate according to the value reported on table 8.0 (see page 24): the numerical value of the oil flow rate (in l/min.) must be set to the motor displacement numerical value (in cm³/turn). Turn the maximum displacement setting screw until the motor turns at 1000 rpm.
4. Lock the adjustment screw with nut and cap nut (with their two washers).
5. With motor unloaded, check that the hand wheel control changes the displacement motor from maximum displacement to minimum displacement and vice-versa. This procedure must be done in both the directions of rotation of the motor.
6. Using an appropriate solvent, check for oil leaks and clean the motor during the following high pressure test.
7. Measure motor leakage and volumetric efficiencies at maximum displacement conditions. Use the procedure as per step 5 using a system pressure of 250 bar and motor input flows to achieve the target speed listed in table 8.0 (see page 24).
8. Check the DRAINAGE FLOW RATE at MINIMUM DISP. Turn the hand wheel until the motor is at minimum displacement. Acceptable value is reported on table 8.0 (see page 24). This test must be done in both rotation directions. Report the highest flow rate in each direction on the test form.
9. Check the DRAINAGE FLOW RATE at MAXIMUM DISP. Turn the hand wheel until the motor is at maximum displacement. Acceptable value of drainage flow rates is reported on table 8.0 (see page 24). This test must be done in both rotation directions. Report the highest flow rate in each direction on the test form.
10. Check the VOLUMETRIC EFFICIENCY (250 bar working pressure) at maximum and minimum displacement with the following formula:
$$\eta_v = \frac{Vg \cdot n}{Q \cdot 1000}$$

Vg = motor displacement (cm³/rev)
n = speed (rpm)
Q = flow (l/min)

The obtained data must not fall below the data in table 8.0 (see page 24).
11. Check for oil leaks. Stop the motor.
12. Fill the motor test form with the required data.

End test

1. Open the lower drainage port S on the motor casing.
2. Remove the motor from the test bench.
3. Check for oil leaks from the front cover and the shaft seal.

Testing Procedures

Control Option PA

Pressure Response Control (Biased to Minimum Displacement)

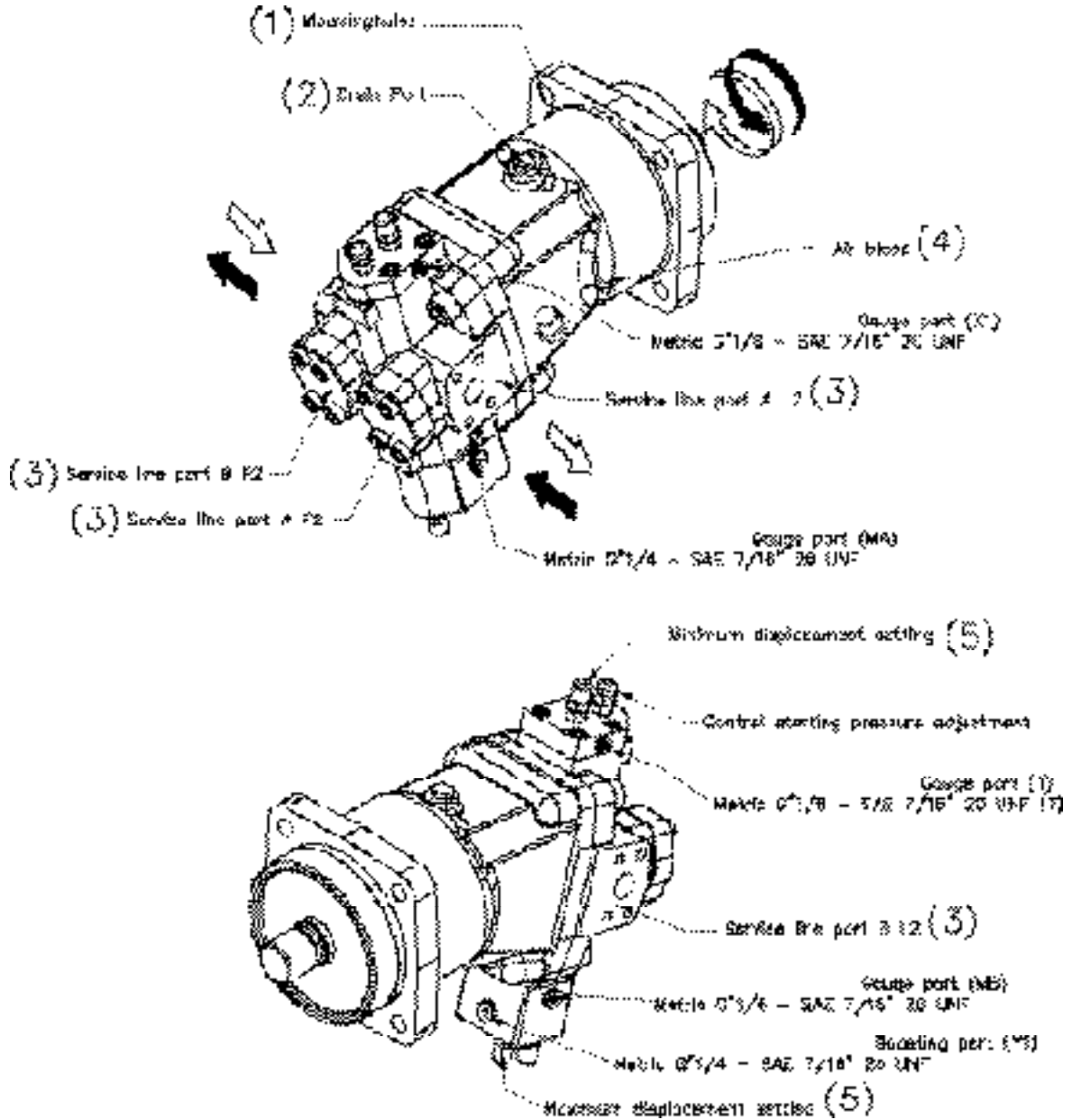

DISPLACEMENT	(1) Mounting Holes		(2) Case Drain Port		(3) High Pressure Ports		(4) Air Bleed Port		(5) MAX/MIN DISPLACEMENT SETTING SCREW VARIATION EACH SCREWTURN
	METRIC	SAE	METRIC	SAE	METRIC	SAE	METRIC	SAE	
BAV 55	Ø 13	Ø 14.3	G 1/2"	1"1/16-12 UN 2B	3/4" SAE 6000	3/4" SAE 6000	G 1/8"	7/16" - 20 UNF	1.4 cm ³ /rev
BAV 75	Ø 14	Ø 20.6	G 1/2"	1"1/16-12 UN 2B	1" SAE 6000	1" SAE 6000	G 1/8"	7/16" - 20 UNF	2 cm ³ /rev
BAV 108	Ø 17	Ø 20.6	G 1/2"	1"1/16-12 UN 2B	1" SAE 6000	1" SAE 6000	G 1/8"	7/16" - 20 UNF	2.6 cm ³ /rev
BAV 161	Ø 18	Ø 20.6	G 1/2"	1"1/16-12 UN 2B	1"1/4 SAE 6000	1"1/4 SAE 6000	G 1/8"	7/16" - 20 UNF	4 cm ³ /rev
BAV 225	Ø 22	Ø 20.6	G 3/4"	1"3/16-12 UN 2B	1"1/4 SAE 6000	1"1/4 SAE 6000	G 1/8"	7/16" - 20 UNF	5 cm ³ /rev

Testing Procedures

Control Option PA

Pressure Response Control (Biased to Minimum Displacement)

1. Check/set MINIMUM DISPLACEMENT (Working pressure must be at least 40 bar). The minimum displacement setting screw and the control pressure setting screw must not run free. The motor is swiveled to the minimum displacement. Set the flow rate according to the value reported on table 8.0 (see page 24): The numerical value of the oil flow rate (in l/min.) must be set equal to the minimum displacement numerical value (in cm³/turn). Adjust the said screw until the motor is running at 1000 rpm.
2. Lock the adjustment screw with nut and locking nut (with their two washers).
3. Check/set MAXIMUM DISPLACEMENT (Working pressure at least 40 bar). The maximum displacement setting screw and the control pressure setting screw must not run free. Turn the pilot-pushing screw until the control swivels the motor to the maximum displacement. Set the oil flow rate according to the value reported on table 8.0 (see page 24). The numerical value of the oil flow rate (in l/min.) must be set equal to the maximum displacement numerical value (in cm³/turn). Adjust the said screw until the motor is running at 1000 rpm.
4. Lock the adjustment screw with nut and locking nut (with their two washers).
5. Using an appropriate solvent, check for oil leaks and clean the motor during the following high pressure test.
6. Measure motor leakage and volumetric efficiencies at maximum displacement conditions. Use the procedure as per step 3 using a system pressure of 250 bar and motor input flows to achieve the target speed listed in table 8.0 (see page 24).
7. Check the DRAINAGE FLOW RATE at MAX. DISP. Acceptable value is reported on table 8.0 (see page 24). This test must be done in both rotation directions. Report the highest flow rate in each direction on the test form.
8. Check the VOLUMETRIC EFFICIENCY (250 bar working pressure) at maximum and minimum displacement with the following formula:

$$\eta_v = \frac{Vg \cdot n}{Q \cdot 1000}$$

Vg = motor displacement (cm³/rev)

n = speed (rpm)

Q = flow (l/min)

9. Check the DRAINAGE FLOW RATE at MINIMUM DISPLACEMENT. Unscrew the pilot-pushing screw until the control swivels the motor back to the minimum displacement (the screw must run free). Acceptable value of drainage flow rate is on table 8.0 (see page 24). This test must be done in both rotation directions. Report the highest flow rate in each direction on the test form.
10. Turn the pilot-pushing screw until the control starts to swivel the motor towards the maximum displacement. From the said position, unscrew approximately 1/2 turn. Lock the said screw with nut and locking nut (with the two washers).
11. Set the working pressure to the required value. Turn the control starting pressure adjustment screw, until the control starts to swivel the motor towards the maximum displacement: lock the screw in this point with nut, locking nut and two washers.
12. Test the control starting pressure by increasing and decreasing the working pressure: when reaching the preset pressure value the control must swivel the motor towards the maximum displacement, keeping the working pressure approximately constant until the maximum displacement is reached, and vice-versa. If necessary, repeat the testing procedure from point 10.
13. Check the VOLUMETRIC EFFICIENCY (250 bar working pressure) at maximum and minimum displacement with the following formula:

$$\eta_v = \frac{Vg \cdot n}{Q \cdot 1000}$$

Vg =
motor displacement (cm³/rev)

n = speed (rpm)

Q = flow (l/min)

The obtained data must not fall below the data in table 8.0 (see page 24).

14. Check for oil leaks. Stop the motor.
15. Fill the motor test form with the required data.

Testing Procedures

Control Option PB

Pressure Response Control with Adjustable Hydraulic Override (Biased to Minimum Displacement)

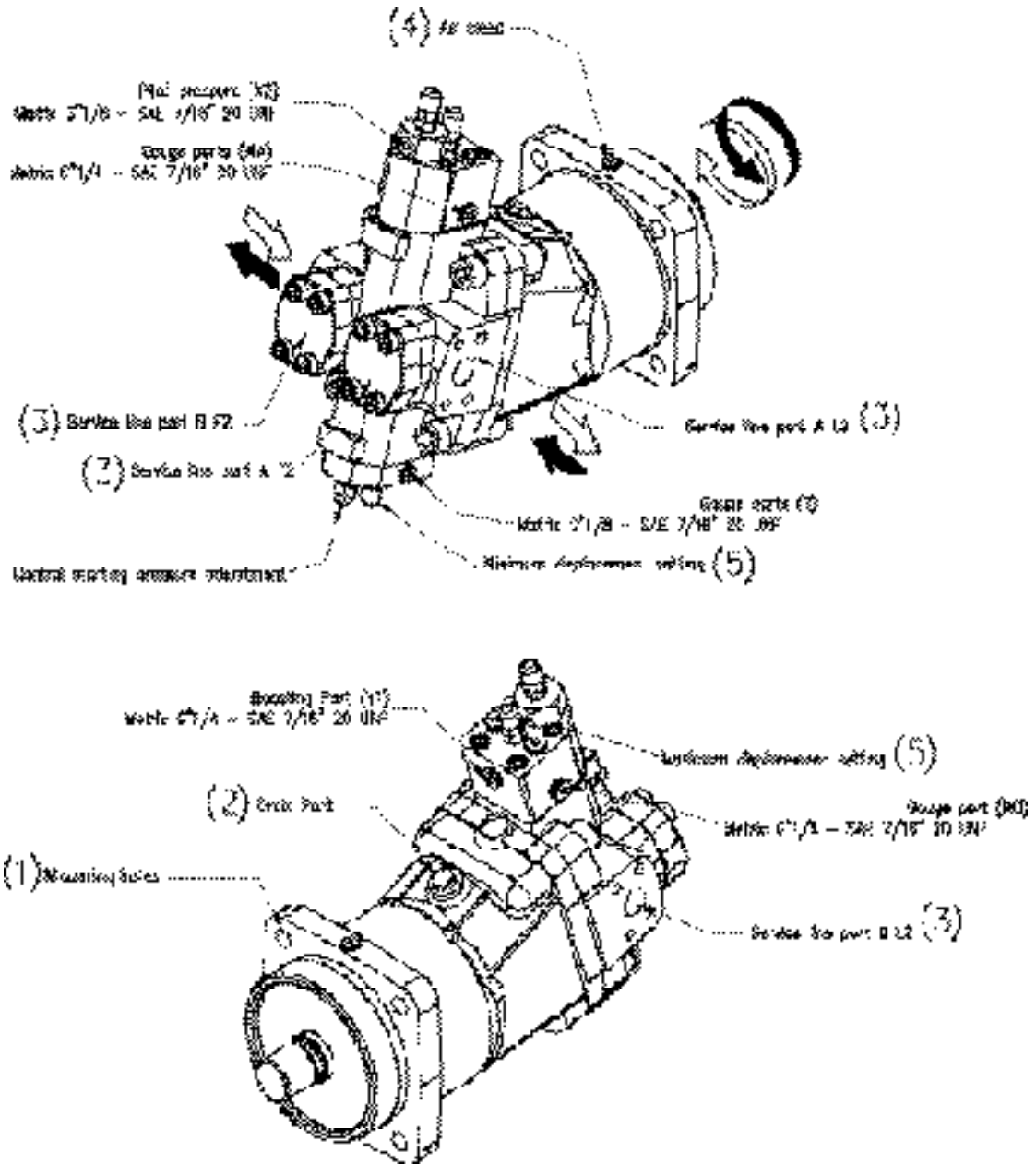

DISPLACEMENT	(1) Mounting Holes		(2) Case Drain Port		(3) High Pressure Ports		(4) Air Bleed Port		(5) MAX/MIN DISPLACEMENT SETTING SCREW VARIATION EACH SCREWTURN
	METRIC	SAE	METRIC	SAE	METRIC	SAE	METRIC	SAE	
BAV 55	Ø 13	Ø 14.3	G 1/2"	1" 1/16-12 UN 2B	3/4" SAE 6000	3/4" SAE 6000	G 1/8"	7/16" - 20 UNF	1.4 cm ³ /rev
BAV 75	Ø 14	Ø 20.6	G 1/2"	1" 1/16-12 UN 2B	1" SAE 6000	1" SAE 6000	G 1/8"	7/16" - 20 UNF	2 cm ³ /rev
BAV 108	Ø 17	Ø 20.6	G 1/2"	1" 1/16-12 UN 2B	1" SAE 6000	1" SAE 6000	G 1/8"	7/16" - 20 UNF	2.6 cm ³ /rev
BAV 161	Ø 18	Ø 20.6	G 1/2"	1" 1/16-12 UN 2B	1 1/4 SAE 6000	1 1/4 SAE 6000	G 1/8"	7/16" - 20 UNF	4 cm ³ /rev
BAV 225	Ø 22	Ø 20.6	G 3/4"	1 3/16-12 UN 2B	1 1/4 SAE 6000	1 1/4 SAE 6000	G 1/8"	7/16" - 20 UNF	5 cm ³ /rev

Testing Procedures

Control Option PB

Pressure Response Control with Adjustable Hydraulic Override (Biased to Minimum Displacement)

1. Running-in of the motor must be done at 500 rpm, half in one rotation direction and half in the other, with pressure from 40 to 100 bar (X2 pressure 0 bar).
2. Check/set MINIMUM DISPLACEMENT (Working pressure at 40 bar). Unscrew the minimum displacement adjustment screw until it runs free. The motor is swiveled to the minimum displacement. Set the flow rate according to the value reported on table 8.0 (see page 24). The numerical value of the oil flow rate (in l/min.) must be set equal to the minimum displacement numerical value (in cm³/turn). Adjust the screw until the motor is running at 1000 rpm.
3. Lock the adjustment screw with nut and locking nut (with their two washers).
4. Check/set MAXIMUM DISPLACEMENT (Working pressure at least 40 bar). Unscrew the maximum displacement adjustment screw until it runs free. Turn the pilot-pushing screw until the control swivels the motor to the maximum displacement. Set the oil flow rate according to the value reported on table 8.0 (see page 24): the numerical value of the oil flow rate (in l/min.) must be set equal to the motor displacement numerical value (in cm³/turn). Adjust the screw until the motor is running at 1000 rpm.
5. Lock the adjustment screw with nut and locking nut (with their two washers).
6. Using an appropriate solvent, check for oil leaks and clean the motor during the following high pressure test. Turn almost fully in the PE pressure setting screw.
7. Check the DRAINAGE FLOW RATE at MAX. DISPLACEMENT. The acceptable value is reported on table 8.0. This test must be done in both rotation directions. Report the highest flow rate in each direction on the test form.
8. Check the VOLUMETRIC EFFICIENCY (250 bar working pressure) at maximum and minimum displacement with the following formula:

$$\eta_v = \frac{Vg \cdot n}{Q \cdot 1000}$$

Vg = motor displacement (cm³/rev)
n = speed (rpm)
Q = flow (l/min)

9. Check the DRAINAGE FLOW RATE at MINIMUM DISPLACEMENT. Unscrew the pilot-pushing screw until the control swivels the motor back to the minimum displacement. Acceptable value of drainage flow rate is on table 8.0 (see page 24). This test must be done in both rotation directions. Report the highest flow rate in each direction on the test form.

10. Check the VOLUMETRIC EFFICIENCY (250 bar working pressure) at maximum and minimum displacement with the following formula:

$$\eta_v = \frac{Vg \cdot n}{Q \cdot 1000}$$

Vg = motor displacement (cm³/rev)
n = speed (rpm)
Q = flow (l/min)

11. Turn the pilot-pushing screw until the control starts to swivel the motor towards the maximum displacement. From this position, unscrew approximately 1/2 turn. Lock the screw with nut, locking nut and two washers.
12. Set the working pressure to the required value. Turn the control starting pressure adjustment screw, until the control starts to swivel the motor towards the maximum displacement: lock the screw in this point with nut locking nut and two washers.
13. Test the control starting pressure by increasing and decreasing the working pressure: when reaching the preset pressure value the control must swivel the motor towards the maximum displacement, keep the working pressure approximately constant until the maximum displacement is reached, and vice-versa. If necessary, repeat the testing procedure from point 11.
14. Test PI control. Test conditions: working pressure = 100 bar, motor in minimum displacement, X2 pressure = 0 bar, speed = 2500 rpm. Increase the piloting pressure until the motor starts to change the displacement (the speed decreases), the pressure must be around 8 bar. Increase the piloting pressure until the motor reaches the maximum displacement, the pressure must be approximately 13 bar.
15. Starting with the motor in maximum displacement, decrease the piloting pressure until the motor has reached the minimum displacement. Check the piloting starting and ending pressures and control stability.
16. Repeat the procedure from point 13 several times and in both rotation directions.
17. Check for oil leaks. Stop the motor.
18. Fill the motor test form with the required data.

End test

1. Open the lower drainage port S on the motor casing.
2. Remove the motor from the test bench.
3. Check for oil leaks from the front cover and the shaft seal.

Testing Procedures

Control Options E5, E6

Two-position Electrical Control with Pressure Response Control with Adjustable Hydraulic Override (Biased to Maximum Displacement)

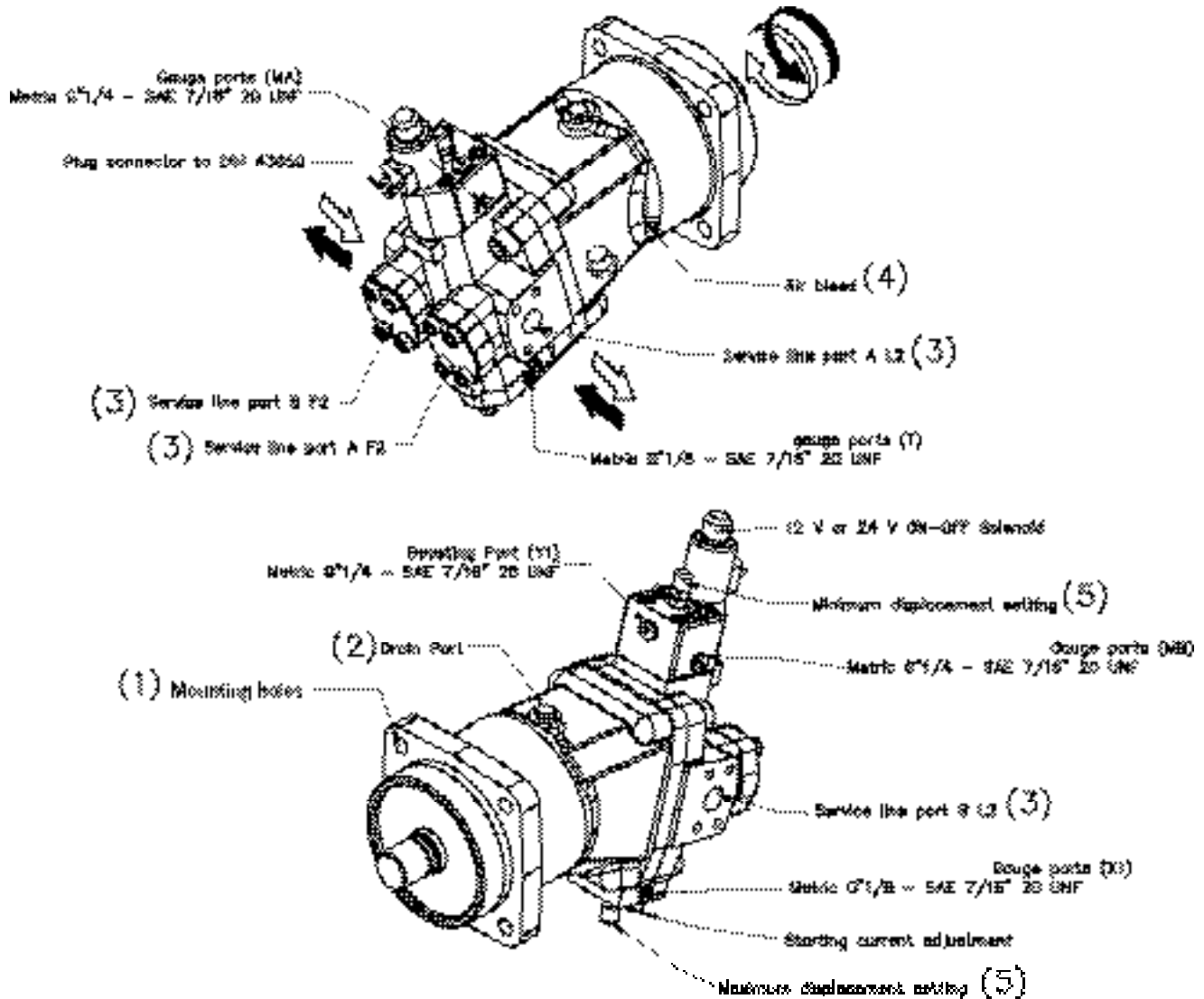

DISPLACEMENT	(1) Mounting Holes		(2) Case Drain Port		(3) High Pressure Ports		(4) Air Bleed Port		(5) MAX/MIN DISPLACEMENT SETTING SCREW VARIATION EACH SCREWTURN
	METRIC	SAE	METRIC	SAE	METRIC	SAE	METRIC	SAE	
BAV 55	Ø 13	Ø 14.3	G 1/2"	1" 1/16-12 UN 2B	3/4" SAE 6000	3/4" SAE 6000	G 1/8"	7/16" - 20 UNF	1.4 cm ³ /rev
BAV 75	Ø 14	Ø 20.6	G 1/2"	1" 1/16-12 UN 2B	1" SAE 6000	1" SAE 6000	G 1/8"	7/16" - 20 UNF	2 cm ³ /rev
BAV 108	Ø 17	Ø 20.6	G 1/2"	1" 1/16-12 UN 2B	1" SAE 6000	1" SAE 6000	G 1/8"	7/16" - 20 UNF	2.6 cm ³ /rev
BAV 161	Ø 18	Ø 20.6	G 1/2"	1" 1/16-12 UN 2B	1" 1/4 SAE 6000	1" 1/4 SAE 6000	G 1/8"	7/16" - 20 UNF	4 cm ³ /rev
BAV 225	Ø 22	Ø 20.6	G 3/4"	1" 3/16-12 UN 2B	1" 1/4 SAE 6000	1" 1/4 SAE 6000	G 1/8"	7/16" - 20 UNF	5 cm ³ /rev

Testing Procedures

Control Options E5, E6

Two-position Electrical Control with Pressure Response Control with Adjustable Hydraulic Override (Biased to Maximum Displacement)

1. Increase the motor working pressure to 40 bar.
2. Check/set MAXIMUM DISPLACEMENT (Working pressure 40 bar). Solenoid OFF (Motor in maximum). Set the flow rate according to the value reported on table 8.0 (see page 24): the numerical value of the oil flow rate (in l/min.) must be set to the motor displacement numerical value (in cm³/turn). Adjust the displacement screw until the motor is running at 1000 rpm.
3. Lock the adjustment screw with nut and locking nut (with their two washers).
4. Check/set MINIMUM DISPLACEMENT (Working pressure 40 bar). Solenoid ON (Motor in minimum). Set the flow rate according to the value reported on table 8.0 (see page 24): the numerical value of the oil flow rate (in l/min.) must be set to the motor displacement numerical value (in cm³/turn). Adjust the displacement screw until the motor is running at 1000 rpm.
5. Lock the adjustment screw with nut and locking nut (with their two washers).
6. Set the solenoid OFF. Rotate the control starting setting screw until it is free to move, then turn it fully in (do not over torque!). Count the number of turns. Back-out the screw by exactly half of the previous number of turns. Lock the screw into position with nut and locking nut.
7. With 0 bar working pressure, check that the control swivels the motor when the solenoid is switched from ON to OFF and vice-versa. This procedure must be done in both the directions of rotation of the motor.
8. Using an appropriate solvent, check for oil leaks and clean the motor during the following high pressure test.
9. Repeat the procedure as per point 4 with a working pressure of 250 bar. Increase input flow to achieve target speed in table 8.0 (see page 24).
10. Check the DRAINAGE FLOW RATE at MAXIMUM DISP. Set working pressure at 250 bar. The acceptable value is reported on table 8.0 (see page 24). This test must be done in both rotation directions. Report the highest flow rate in each direction on the test form.
11. Check the DRAINAGE FLOW RATE at MINIMUM DISP. Set solenoid ON (motor to the minimum displacement). Screw fully in the PE pressure setting screw. Set working pressure at 250 bar. The acceptable value of drainage flow rate is reported on table 8.0 (see page 24). This test must be done in both rotation directions. Report the highest flow rate in each direction on the test form.
12. Check the VOLUMETRIC EFFICIENCY (250 bar working pressure) at maximum and minimum displacement with the following formula:
$$\eta_v = \frac{Vg \cdot n}{Q \cdot 1000}$$

Vg = motor displacement (cm³/rev)
n = speed (rpm)
Q = flow (l/min)

The obtained data must not fall below the data in table 8.0 (see page 24).
13. Set the working pressure to the required PE setting pressure value. Solenoid ON (motor to minimum displacement). Turn the PE pressure setting screw, turn it until the motor swivels to the maximum displacement. Check the correct setting increasing the working pressure several times in both the directions of rotation: the motor must swivel to the maximum displacement every time the PE setting pressure is reached. Tighten the locking nut with its washer.
14. Check for oil leaks. Stop the motor.
15. Fill the motor test form with the required data.

End test

1. Open the lower drainage port S on the motor casing.
2. Remove the motor from the test bench.
3. Check for oil leaks from the front cover and the shaft seal.

BAV Critical Dimensions

Belleville Spring Design

PART IDENTIFICATION

- A = Front cover shims
- B = Nominal valve plate measurement from back cover
- C = Belleville spring preload setting: check meas. C (mm) with valve plate in the shown position (without paper gasket)
- D = Nominal Belleville shimming

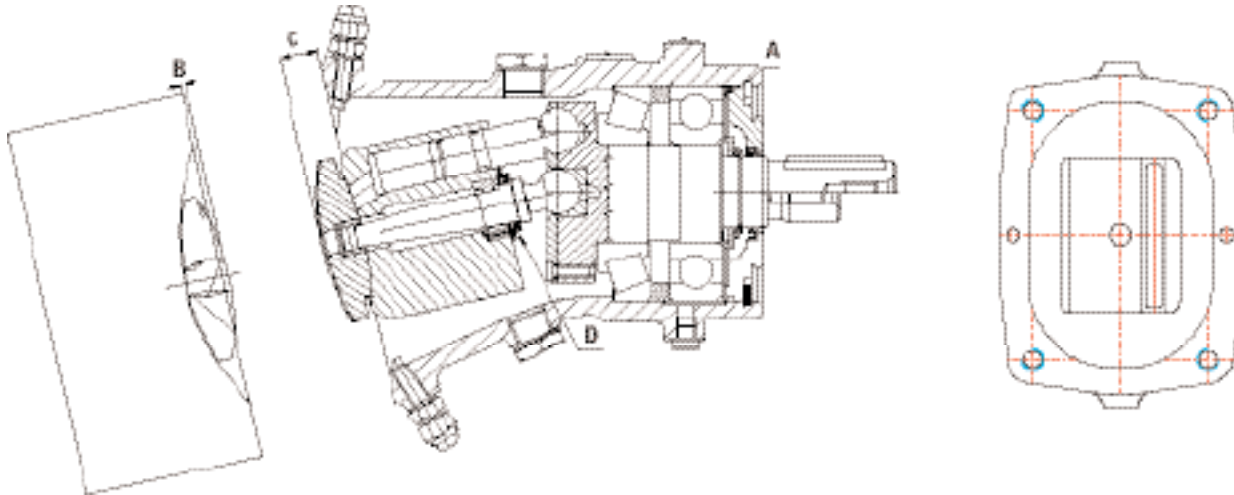

TABLE 9.0
BENT AXIS
FIXED DISPLACEMENT PARTS

DISPLACEMENT	DIM A(mm)	DIM B(mm)	DIM C(mm) GAP BETWEEN HOUSING & END COVER (REAR END COVER BOLTS LOOSE)				DIM D(mm)		
			VALVE PLATE ONLY PA - PB H1, H2		PA - PB H1, H2				
55	1.2 ⁰ _{-0.2}	11.3 ±0.1	12.9 ±0.1	12.6 ±0.1	1.4 ±0.1	1.1 ±0.1	2		
75	0.6 ^{+0.2} _{-0.1}	10.2 ±0.1	14.9 ±0.1	14.6 ±0.1	1.4 ±0.1	1.1 ±0.1	3		
108	1.5 ^{+0.2} ₋₀	13.7 ±0.1	16.1 ±0.1	15.8 ±0.1	15.6 ±0.1	1.5 ^{+0.2} ₀	1.2 ^{+0.2} ₀	1 ^{+0.2} ₀	3
161	1.5 ±0.1	5.3 ±0.1	29.1 ±0.1	28.8 ±0.1	1.6 ±0.1	1.3 ±0.1	0.8		
225	0.5 ±0.1	6.8 ±0.1	36.6 ±0.1	36.3 ±0.1	1.6 ±0.1	1.3 ±0.1	0.5		

PART IDENTIFICATION

- A = Front cover shims
- B = Center Pivot Shims
- C = Valve plate protusion beyond housing
- D = Bearing shims

TABLE 10.0
ASSEMBLY DIMENSIONS

DISPLACEMENT (CM ²)	DIM A(mm)	DIM B(MM)	DIM C(mm)	DIM D(mm)
20	1.2 ^{+0.2} _{-0.2}	0.08 ^{+0.1} _{-0.1}	1.4 ^{+0.1} _{-0.1}	0 ÷ 0.5
30	1.2 ^{+0.2} _{-0.2}	0.08 ^{+0.1} _{-0.1}	1.4 ^{+0.1} _{-0.1}	0 ÷ 0.5
40	1.2 ⁺⁰ _{-0.2}	2.4 ^{+0.1} _{-0.1}	1.4 ^{+0.1} _{-0.1}	0 ÷ 0.5
55	1.2 ⁺⁰ _{-0.2}	2.4 ^{+0.1} _{-0.1}	1.4 ^{+0.1} _{-0.1}	0 ÷ 0.5
75	0.6 ^{+0.2} _{-0.1}	2.5 ^{+0.2} _{-0.2}	1.4 ^{+0.1} _{-0.1}	0 ÷ 0.5
90	1.5 ^{+0.2} ₋₀	3 ^{+0.2} ₋₀	1.5 ^{+0.2} ₋₀	0 ÷ 0.5
108	1.5 ^{+0.2} ₋₀	3 ^{+0.2} ₋₀	1.5 ^{+0.2} ₋₀	0 ÷ 0.5
161	1.5 ^{+0.1} _{-0.1}	1.2 ^{+0.1} _{-0.1}	1.6 ^{+0.1} _{-0.1}	0 ÷ 0.5
225	1.5 ^{+0.1} _{-0.1}	0.7 ^{+0.2} _{-0.2}	1.6 ^{+0.1} _{-0.1}	0 ÷ 0.5

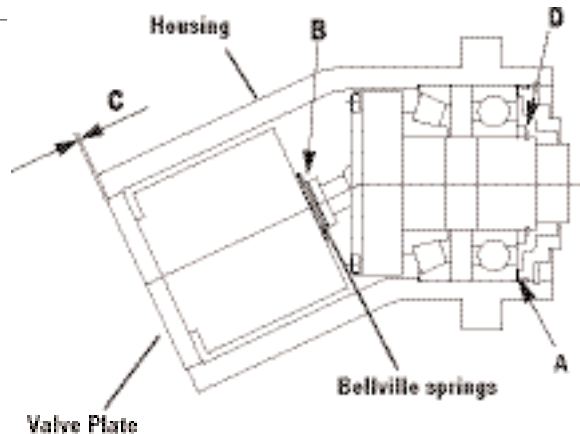

Special Tools

TABLE 10.0 TOOL SIZES

ITEM	BAV55	BAV75	BAV106	BAV161	BAQV225
1	2.5	2.5	2.5	2.5	2.5
	4	4	4	4	4
	5	5	5	5	5
	6	6	6	6	6
	8	8	8	8	8
		10	10	10	10
2	12			12	12
		14	14	14	
					17
3	13				
	17	17	17	17	17
				19	19
	30	30	30	30	30
4	Circlip diameter Ø18				
5	Plastic mallet				
5	Torque wrench				

NOTE: All tools sizes in mm.

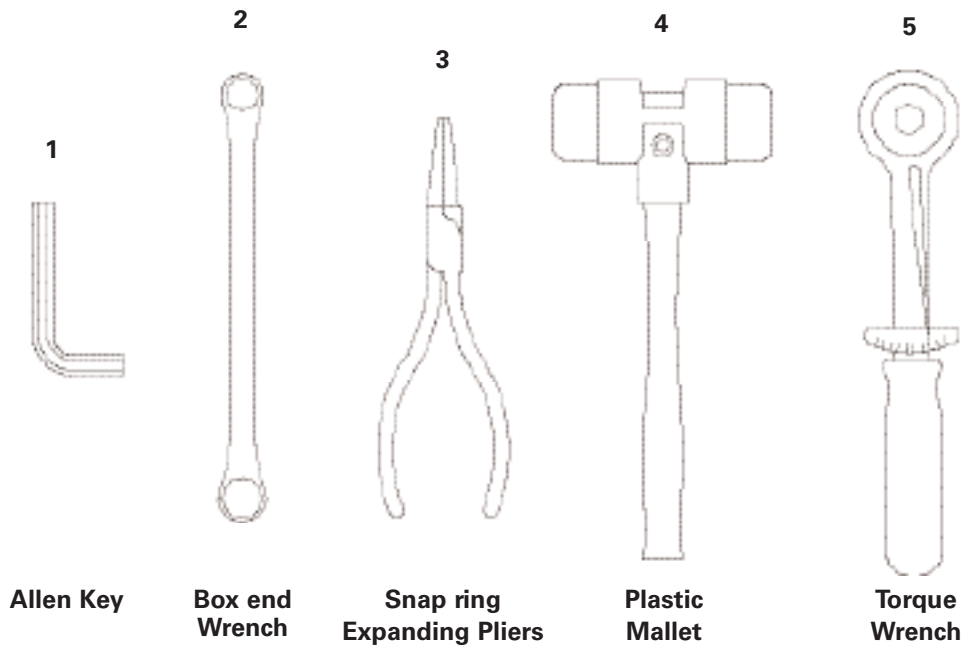

Eaton
14615 Lone Oak Road
Eden Prairie, MN 55344
USA
Telephone: 952 937-9800
Fax: 952 974-7722
www.hydraulics.eaton.com

Eaton
20 Rosamond Road
Footscray
Victoria 3011
Australia
Tel: (61) 3 9319 8222
Fax: (61) 3 9318 5714

Eaton
Dr. Reckeweg-Str. 1
D-76532 Baden-Baden
Germany
Tel: (49) 7221 682-0
Fax: (49) 7221 682-788

