

# Installation Information

E-MOPI-TI003-E  
Supersedes 4-416



## Eaton® Heavy Duty Series Piston Motors

# 109823-000 Speed Sensor

**Eaton**  
14615 Lone Oak Road  
Eden Prairie, MN 55344  
Telephone: 952 937-9800  
Fax: 952 974-7722  
www.hydraulics.eaton.com

**Eaton**  
Dr.-Reckeweg-Str. 1  
D-76532 Baden-Baden  
Germany  
Tel:+49 (0) 7221 682-0  
Fax:+49 (0) 7221 682-788

# CAUTION

Exceeding the specified amount of torque may permanently damage this sensor. Read installation instructions before installing the sensor.

This digital speed sensor is used to monitor the speed of an Eaton Heavy Duty Series piston motor.

- 1 Make sure the hydraulic power is turned off and the motor can not rotate before proceeding.
- 2 Screw the digital speed sensor CW into the motor's end cover until the end just touches the shaft.
- 3 Unscrew the sensor CCW 60° ± 10° to provide running clearance.

**Note: The angle between each of the flat wrenching surfaces on the nut is 60°. These flats can be used to estimate the backoff distance of CCW rotation.**

- 4 Continue to unscrew the sensor CCW until the flats on the sensor are parallel with the motor shaft (see drawing below).
- 5 Maintain the sensor position and tighten the seal nut to a torque of 13,6 ± 1,4 Nm [120 ± 12 lb-in].
- 6 If sensor flats are not parallel with motor shaft; loosen seal nut, realign sensor and retorque to value specified in step 5.

**Important Note: More torque than the specified amount may permanently damage the sensor.**

© 2005 Eaton Corporation  
All Rights Reserved  
Document No. E-MOPI-TI003-E  
Supersedes 4-416  
June, 2005

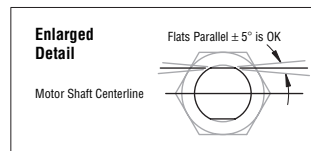
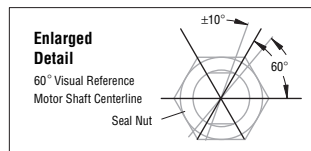

Flats Parallel Centerline  
Motor Shaft Centerline

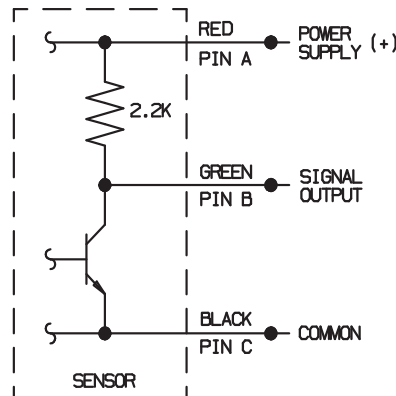
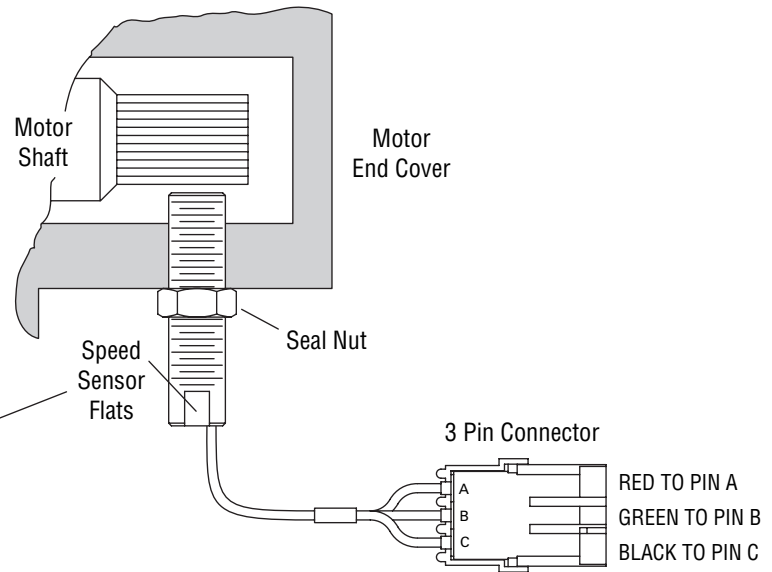
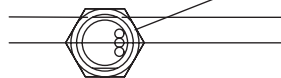

PACKARD ELECTRIC WEATHER PACK SERIES  
12010717 CONNECTOR (BLACK WITH INDEX CODE 101)  
(MATES WITH 12015793, CONNECTOR AND  
12089188, SLEEVE TERMINAL FEMALE)  
12015323 SEAL (3 SEALS)  
12089040 PIN (3 PINS)