



Char-Lynn

Power Steering Steering Control Unit (SCU)

Parts and Repair Information

5 Series
Steering
Control Units
001

**Square Housing
with Side Ports**

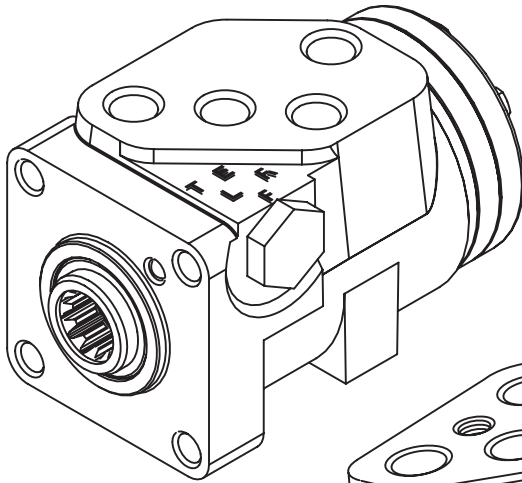

**Round Housing
with Side Ports**

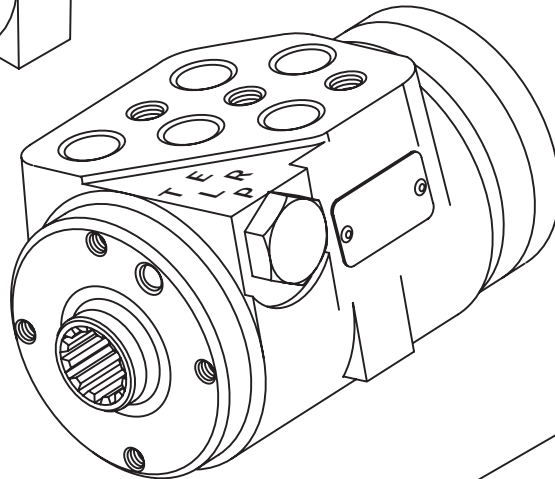

**Round Housing
with End Ports**

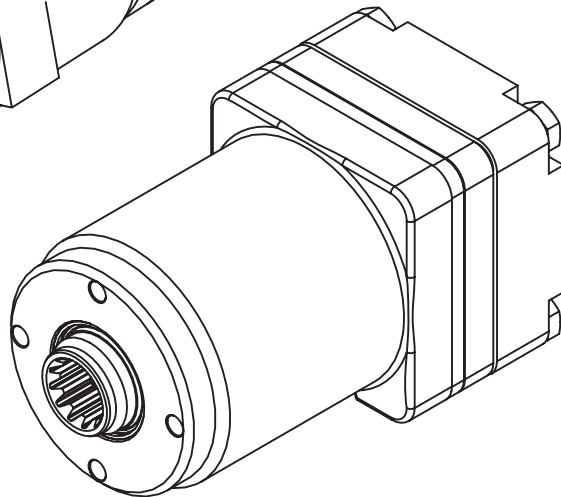

Series 5 Steering Control Unit Table of Contents

Introduction	2
General Information	
Ordering Parts	3
Tools	3
Round and Square Housing with Side Ports	
Exploded View	4
Parts List	5
Disassembly	6
Reassembly	7
Round Housing with End Ports	
Exploded View	8
Parts List	9
Disassembly	10
Reassembly	11
2-Piece Shaft Seal Assembly	12

Introduction

This manual provides service information for Char-Lynn® Series 5 Steering Control Units. Step by step instructions for complete disassembly, inspection and reassembly of the control unit are given.

The following recommendations should be followed to insure successful repairs.

- Most repairs require the removal of the control unit from the vehicle.
- Cleanliness is extremely important.
- Clean the port areas thoroughly before disconnecting the hydraulic lines.
- Plug the control unit ports and cover open hydraulic lines immediately after they have been disconnected.
- Drain the oil and clean the exterior of the control unit before making repairs.
- Wash all metal parts in clean solvent.
- Use filtered, moisturefree compressed air to dry the parts. Do not wipe them dry with paper towels or cloth – lint in a hydraulic system will cause damage.
- Always use new seals when reassembling hydraulic control units.
- Lubricate new rubber seals with a petroleum jelly before installation.
- Torque all bolts over gasketed joints, then repeat the torquing sequence to make up for gasket compression.

After all repairs are complete it is essential to verify the accuracy of control unit repairs on an authorized test stand.

General Information

Ordering Parts

How to Order Replacement Parts

Each order must include the following:

1. Product Number
2. Date Code
3. Part Name
4. Part Number
5. Quantity of Parts

Refer to specific part listings for your Char-Lynn® Steering Control Unit when ordering replacement parts. Listings are available from Eaton. Sample tag shows identification.

For additional literature contact Eaton Hydraulics at:

14615 Lone Oak Road
Eden Prairie, MN 55344

<http://hydraulics.eaton.com>

Bar Code Label — Launch Date June, 1999

Customer part number or base unit number if it has a column or valve assembled

Month / Day / Year

Eaton Part Number

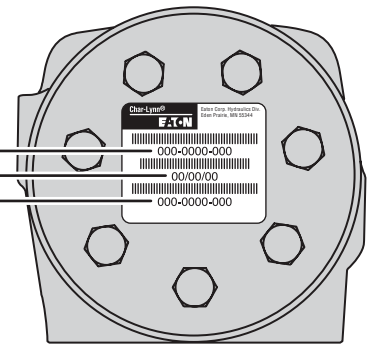

Port Face

Tools

Tools Required:

- 10 mm Socket (13 mm Socket for End-Ported Units)
- 7/8 in. Socket
- Torque Wrench (31 Nm [275 lb-in] Capacity)
- Small Blade Screwdriver

Special Tools:

- Plunger and Sleeve Tool (two-piece seal) No. 600801-001*
- * Tools available—by special order—through our service department.

Round and Square Housing with Side Ports

Exploded View

*Round housing shown, but applies to square housing also.

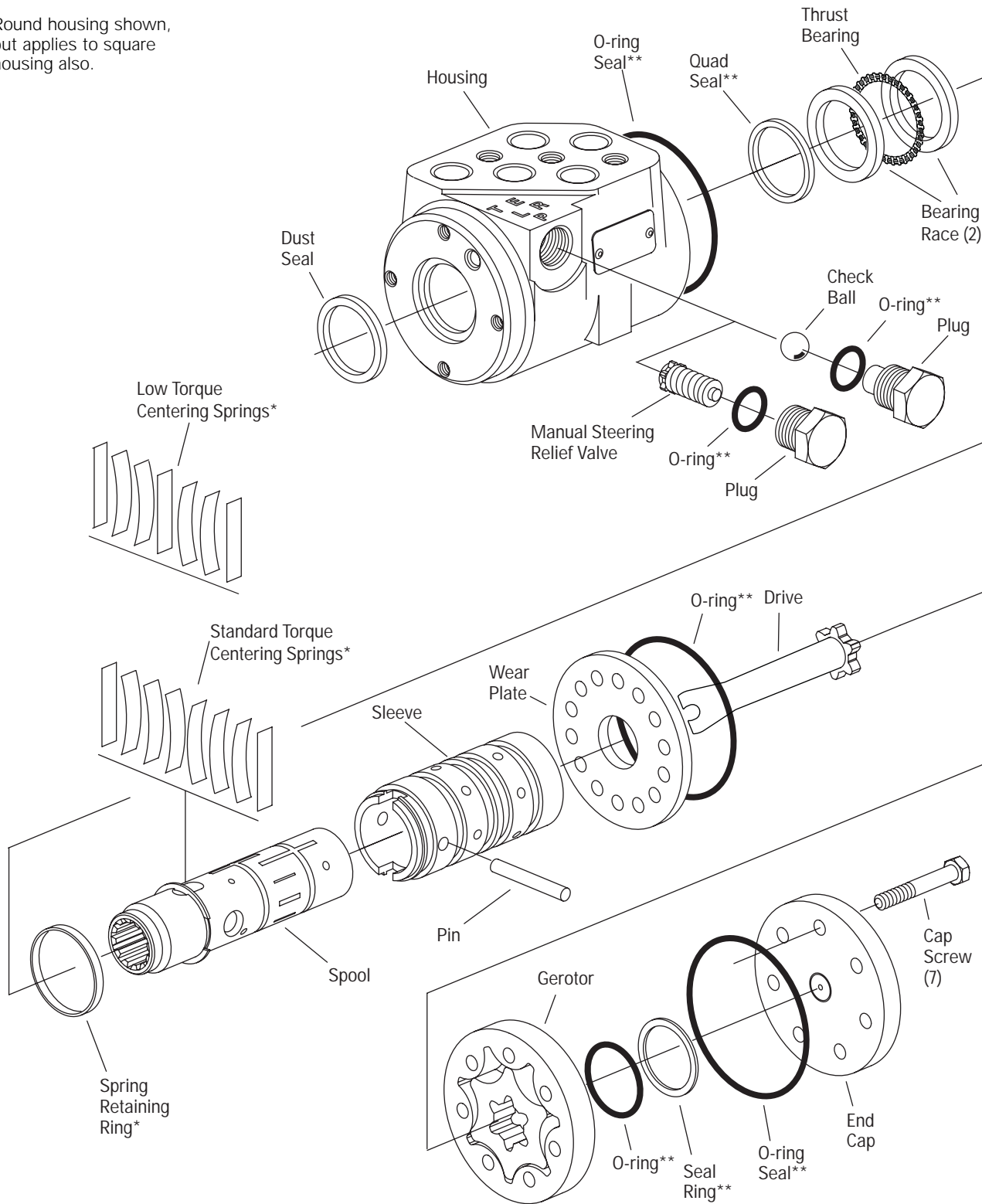

Round and Square Housing with Side Ports

Parts List

Table 1.0
Round and Square Housing with Side Ports

ITEM NO.	PART NO.	QTY.	DESCRIPTION	REFERENCE PAGE
1	See Table 2.0	7	Cap Screw, Hex Head	6
2	22994-000	1	Cap, End	
4	See Table 2.0	1	Gerotor, Sub-assembly	6
5	22993-000	1	Wear Plate	
6	4994693-001	1	Drive	
9	22853-000	1	Drive Pin	
13	4997396-001	2	Bearing Race	
14	4996933-001	1	Bearing, Needle Thrust	
16	4997708-001	1	Dust Seal	

REPLACEMENT PART NO.	DESCRIPTION
64456-00	Centering Spring Kit - Standard Torque (contains parts with *)
990170-000	Centering Spring Kit - Low Torque (contains parts with **)
990252-000	Seal Kit - Standard Back Pressure (contains parts with **)
9900256-000	Seal Kit - High Back Pressure (contains parts with **)
9900321-000	Seal Kit - Viton, PM Gerotor (contains parts with **)
9900323-000	Seal Kit - Viton, Steel Gerotor (contains parts with **)

Table 2.0
Gerotor

ACTUAL DISPLAY	REFERENCE NO. 4 GEROTOR		REFERENCE NO. 29 CAP SCREW	
cm ² /r [in ² /r]	Part No.	Width mm [in]	Part No.	Length mm [in]
31.5 [1.92]	4996815-001	7.45 [.290]	14543-003	35 [1.38]
39.5 [2.41]	4996815-002	9.3 [.366]	14543-003	35 [1.38]
50.8 [3.10]	4996815-003	8.3 [.326]	14543-003	35 [1.38]
63.1 [3.85]	4996815-004	10.2 [.400]	14543-003	35 [1.38]
73.8 [4.50]	4996815-005	12.1 [.476]	14543-002	40 [1.57]
100 [6.10]	4996815-006	16.3 [.642]	14543-004	45 [1.77]
120 [7.33]	4996815-007	19.5 [.768]	14543-004	45 [1.77]

Round and Square Housing with Side Ports - Disassembly

Disassembly

Cleanliness is extremely important when repairing hydraulic Steering Control Units (SCU). Work in a clean area. Before disconnecting the hydraulic lines, clean the port area of the SCU. Before disassembly, drain the oil, then plug the ports and thoroughly clean the exterior of the SCU. During repairs, always protect machined surfaces.

1. Remove the seven cap screws and disassemble the SCU as shown in figure 1.

2. Remove the plug and manual steering check as shown in figure 1.
Note: The manual steering check may be a check ball or a check/relief valve.
3. Slide the spool and sleeve from the housing, see figure 2.
4. Remove the thrust bearing and bearing races.
5. Remove the quad seal.

6. Using a small blade screwdriver, carefully pry the dust seal from the housing.
Important: Do not damage the dust seal seat.
7. Remove the pin that holds the spool and sleeve together, see figure 3.
8. Carefully slide the spool out of the sleeve. The springs and retaining ring will stay with the spool as it's removed.

9. Remove the retaining ring and springs.
Caution: The centering springs are under tension; remove the retaining ring carefully.

Figure 1

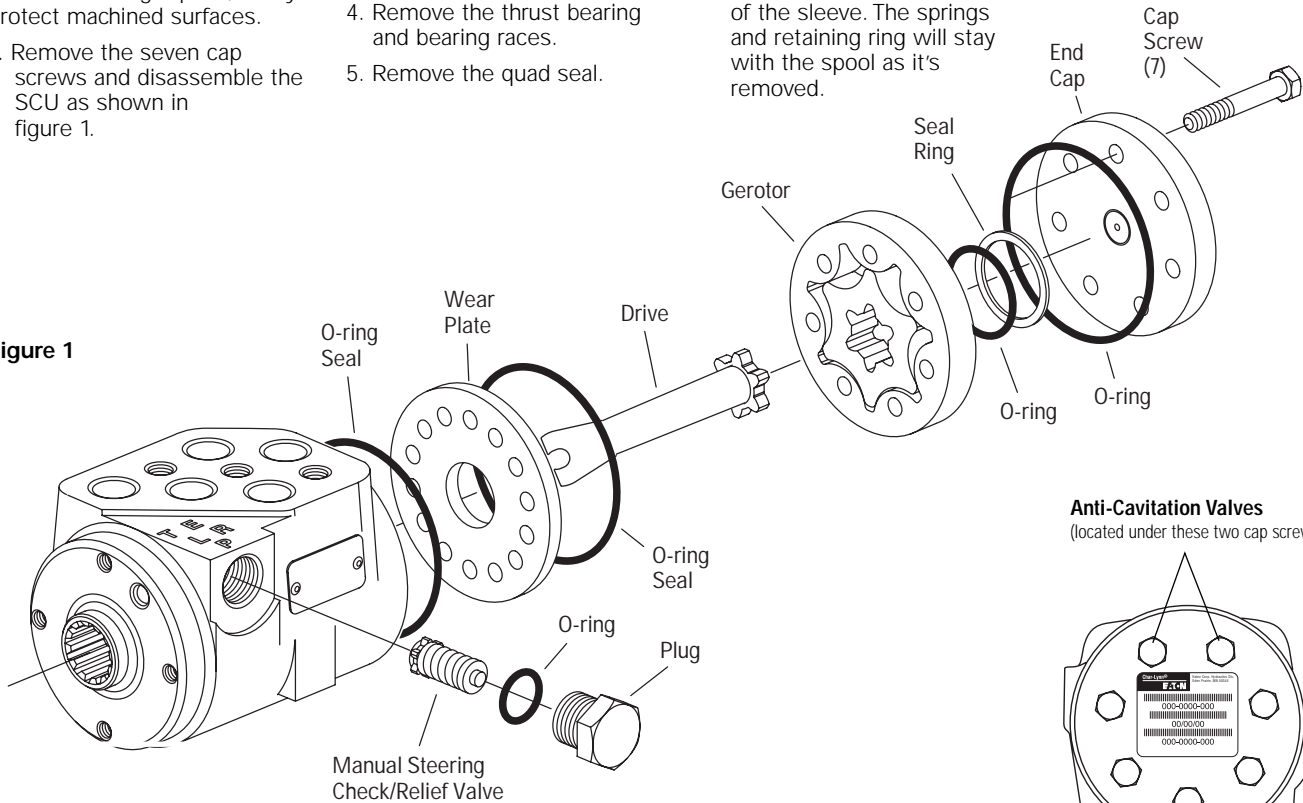

Anti-Cavitation Valves

(located under these two cap screws)

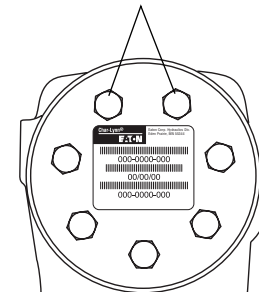

Port Face

Figure 2

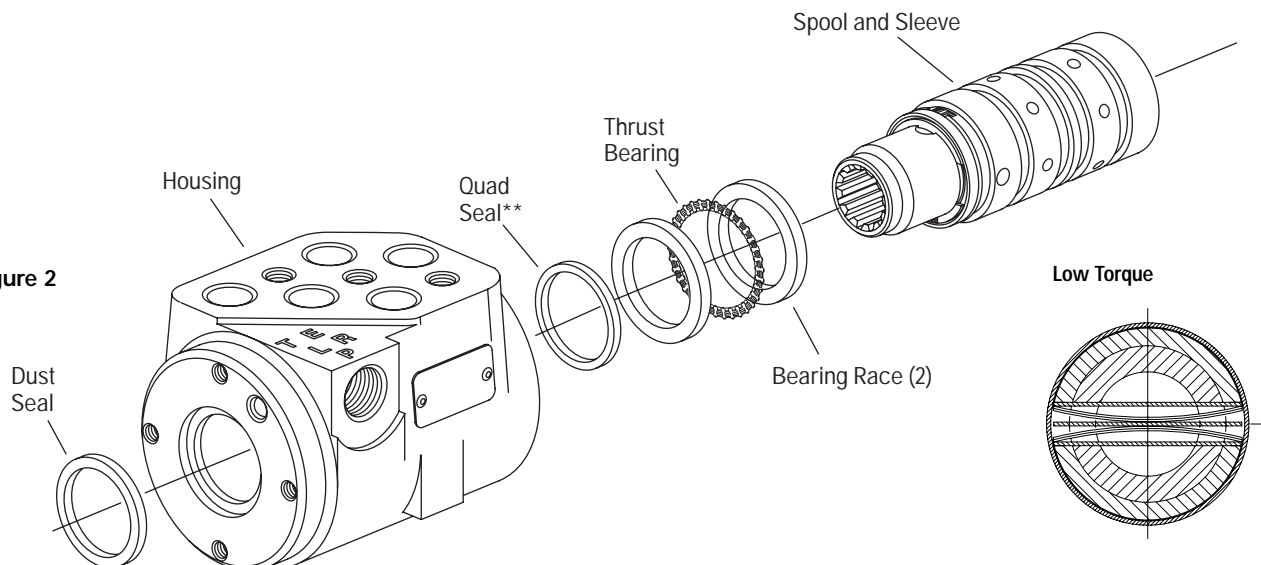

Round and Square Housing with Side Ports - Reassembly

Reassembly

Check all mating surfaces. Replace any parts with scratches or burrs that could cause leakage. Wash all metal parts in clean solvent. Blow them dry with pressurized air. Do not wipe parts dry with paper towels or cloth as lint in a hydraulic system will cause damage.

Note: Always use new seals when reassembling hydraulic steering control units. Refer to page 5 for seal kit part numbers.

Important: During reassembly lubricate the new seals with a petroleum jelly such as Vaseline®. Also lubricate machined surfaces and bearings with clean hydraulic fluid.

10. Install the quad seal (see page 12 for 2-piece seal installations):

- Put one of the bearing races and sleeve into the housing.
- Together, the housing and bearing race create a groove into which the quad seal will be installed.
- Hold the bearing race tightly against the input end of the housing by pushing on the gerotor end of the sleeve.
- Fit the quad seal into its seat through the input end of the housing. Be sure the seal is not twisted.
- Remove the sleeve and bearing race.

11. Lubricate and install the dust seal (see Figure 4 for correct seal orientation).

Figure 4

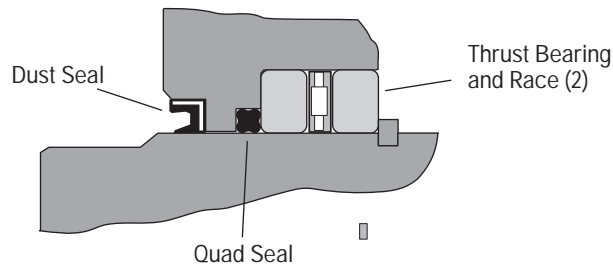
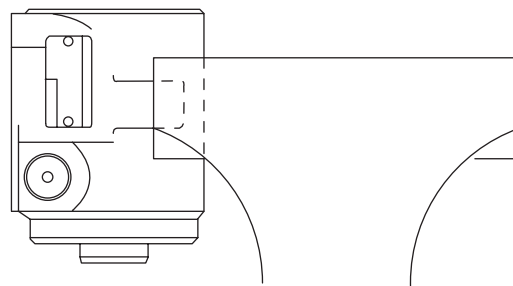

Figure 5



12. Install the centering springs in the spool. It is best to install the two flat pieces first. Next, install the curved pieces, three at a time.
13. Fit the retaining ring over the centering springs.
14. Apply a light coating of clean hydraulic fluid to the sleeve and slide it into the housing. Be sure the centering springs fit into the notches in the sleeve.

15. Install the drive, be sure the slot in the drive engages the pin.
16. Install the pin (see Figure 3).
17. Apply a light coating of petroleum jelly to the inner edge of the dust and quad seals.
18. Put the thrust bearing and races into the housing. The thrust bearing goes between the two races (see Figure 2).



Figure 3

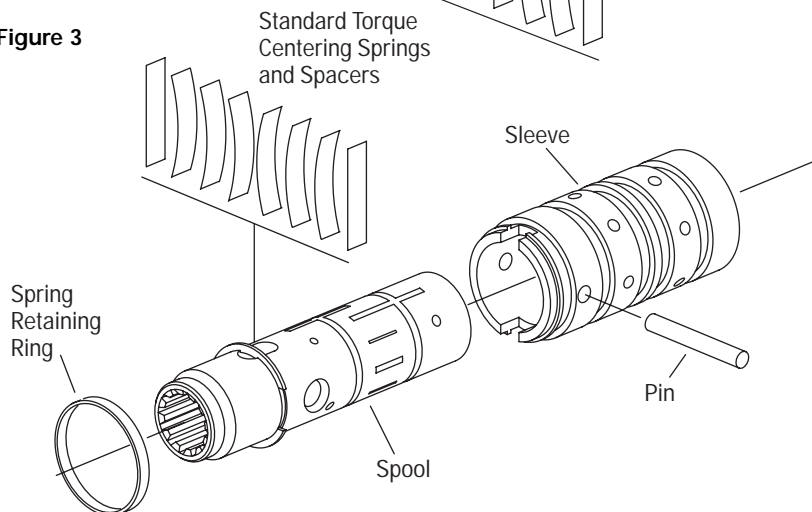

19. Apply a light coating of clean hydraulic fluid to the spool and sleeve assembly and slide it into the housing.

Important: Do not damage the dust or quad seals..

20. Clamp the housing in a vise as shown in Figure 5. Use just enough clamping force to hold the housing securely.

21. Lubricate and install a new o-ring seal in the groove in the housing.

22. Install the wear plate and align the holes in the wear plate with threaded holes in the housing.

Note: The holes in the wear plate are symmetrical.

23. Lubricate and install a new o-ring seal in the groove in the wear plate.

24. Install the gerotor and align the screw holes.

25. Lubricate and install a new o-ring seal in the groove in the gerotor ring.

26. Lubricate and install a new o-ring and seal ring in the groove in the gerotor star.

27. Install end cap and seven cap screws. Tighten cap screws, in a crisscross pattern, to 16 -18 Nm [140 -160 lb-in].

28. Remove the SCU from the vise.

29. Install the relief valve/check or check ball and plug. Use a new o-ring and tighten the plug to 17 Nm [150 lb-in].

Round Housing with End Ports Exploded View

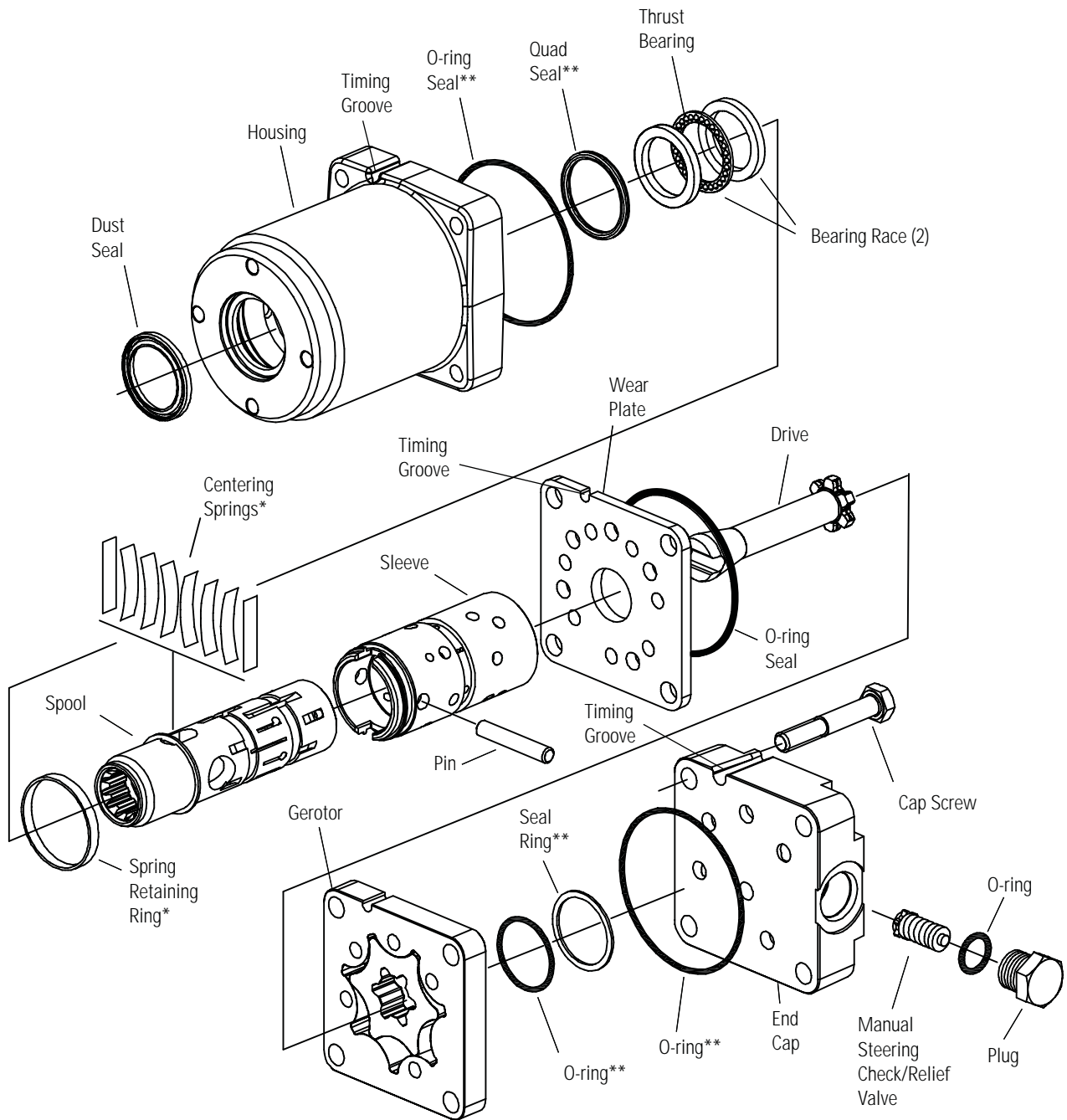

Round Housing with End Ports Parts List

Table 3.0
Round Housing with
End Ports

ITEM NO.	PART NO.	QTY.	DESCRIPTION	REFERENCE PAGE
1	See Table 4.0	4	Cap Screw, Hex Head	10
2	4993924-XXX	1	Cap, End (Non-load sense, non-STC only)	
4	See Table 4.0	1	Gerotor, Sub-assembly	10
5	4993805-001	1	Wear Plate	
6	4994693-001	1	Drive	
9	22853-000	1	Drive Pin	
13	4997396-001	2	Bearing Race	
14	4996933-001	1	Bearing, Needle Thrust	
16	4997708-001	1	Dust Seal	

REPLACEMENT PART NO.	DESCRIPTION
64456-00	Centering Spring Kit - Standard Torque (contains parts with *)
990170-000	Centering Spring Kit - Low Torque (contains parts with **)
990252-000	Seal Kit - Standard Back Pressure (contains parts with **)
9900256-000	Seal Kit - High Back Pressure (contains parts with **)
9900321-000	Seal Kit - Viton, PM Gerotor (contains parts with **)
9900323-000	Seal Kit - Viton, Steel Gerotor (contains parts with **)

Table 4.0
Gerotor

ACTUAL DISPLAY	REFERENCE NO. 4 GEROTOR	REFERENCE NO. 29 CAP SCREW
cm ² /r [in ² /r]	Part No.	Part No.
	Width mm [in]	Length mm [in]
31.5 [1.92]	4998582-001	4994536-045
39.5 [2.41]	4998582-002	4994536-050
50.8 [3.10]	4998582-003	4994536-045
63.1 [3.85]	4998582-004	4994536-050
73.8 [4.50]	4998582-005	4994536-050
100 [6.10]	4998582-006	4994536-055
120 [7.33]	4998582-007	4994536-060

Round Housing with End Ports - Disassembly

Disassembly

Cleanliness is extremely important when repairing hydraulic Steering Control Units (SCU). Work in a clean area. Before disconnecting the hydraulic lines, clean the port area of the SCU. Before disassembly, drain the oil, then plug the ports and thoroughly clean the exterior of the SCU. During repairs, always protect machined surfaces.

1. Remove the plug and inlet relief as shown in figure 1.
Note: The manual steering check is part of the inlet relief valve. If inlet relief valve is not present, the manual steering check is located in the housing.
2. Remove the four cap screws and disassemble the SCU as shown in figure 1.
3. Slide the spool and sleeve from the housing, see figure 2.
4. Remove the thrust bearing and bearing races.
5. Remove the seal.
6. Using a small blade screwdriver, carefully pry the dust seal from the housing.
Important: Do not damage the dust seal seat.
7. Remove the pin that holds the spool and sleeve together, see figure 3.
8. Carefully slide the spool out of the sleeve. The springs and retaining ring will stay with the spool as it's removed.
9. Remove the retaining ring and springs.
Caution: The centering springs are under tension; remove the retaining ring carefully.

Figure 1

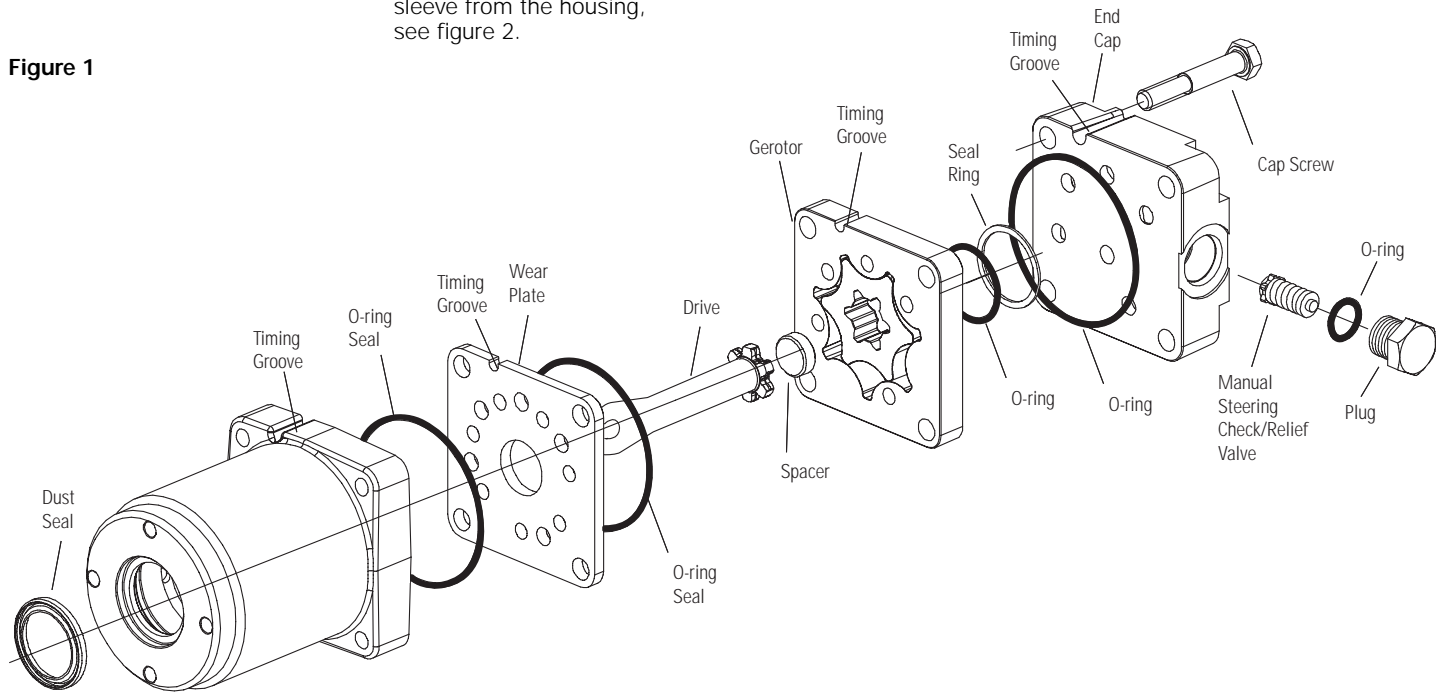
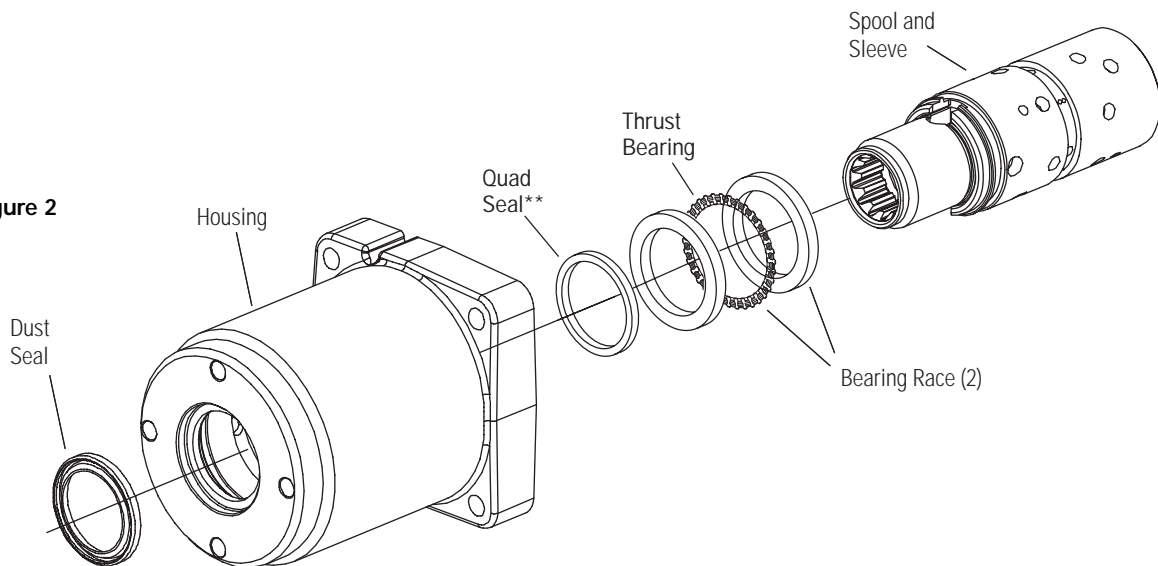

Figure 2



Round Housing with End Ports - Reassembly

Reassembly

Check all mating surfaces. Replace any parts with scratches or burrs that could cause leakage. Wash all metal parts in clean solvent. Blow them dry with pressurized air. Do not wipe parts dry with paper towels or cloth as lint in a hydraulic system will cause damage.

Note: Always use new seals when reassembling hydraulic steering control units. Refer to seal kit part numbers on page 6.

Important: During reassembly lubricate the new seals with a petroleum jelly such as Vaseline®. Also lubricate machined surfaces and bearings with clean hydraulic fluid.

10. Install the quad seal: (see page 12 for 2-piece seal installations):

- Put one of the bearing races and sleeve into the housing.
- Together, the housing and bearing race create a groove into which the quad seal will be installed.
- Hold the bearing race tightly against the input end of the housing by pushing on the gerotor end of the sleeve.
- Fit the quad seal into its seat through the input end of the housing. Be sure the seal is not twisted.
- Remove the sleeve and bearing race.

11. Lubricate and install the dust seal (see Figure 4 for correct seal orientation).

Figure 4

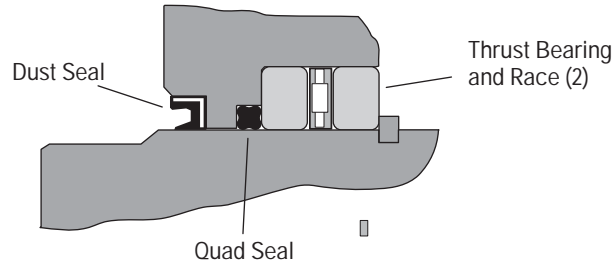
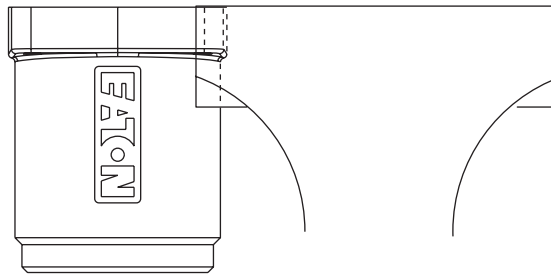

Figure 5



12. Install the centering springs in the spool. It is best to install the two flat pieces first. Next, install the curved pieces, three at a time.
13. Fit the retaining ring over the centering springs.
14. Apply a light coating of clean hydraulic fluid to the spool and slide it into the sleeve. Be sure the centering springs fit into the notches in the sleeve.

15. Install the pin (see Figure 3).
16. Apply a light coating of petroleum jelly to the inner edge of the dust and quad seals.
17. Put the thrust bearing and races into the housing. The thrust bearing goes between the two races (see Figure 2).

Figure 3

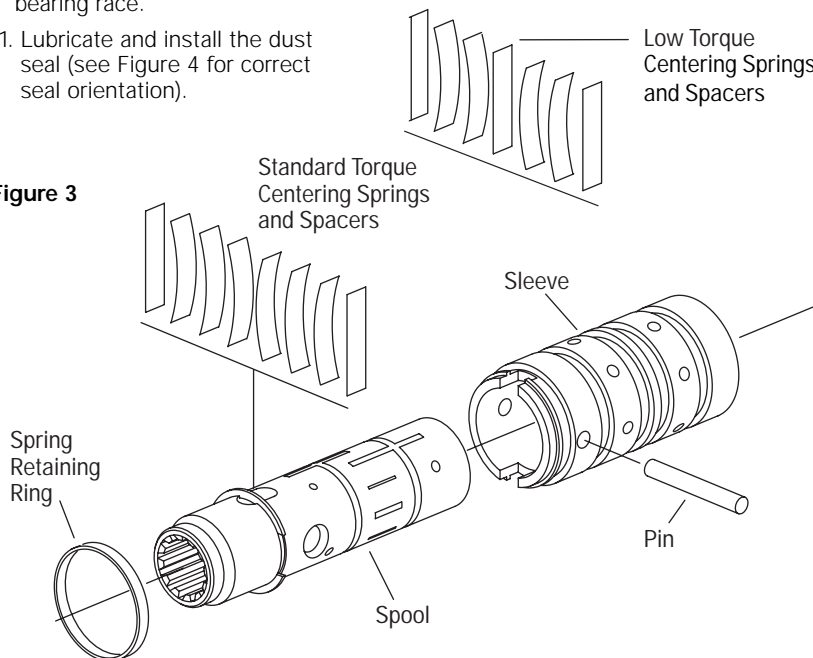

18. Apply a light coating of clean hydraulic fluid to the spool and sleeve assembly and slide it into the housing.
- Important:** Do not damage the dust or quad seals.
19. Clamp the housing in a vise as shown in Figure 5. Use just enough clamping force to hold the housing securely.
20. Install manual steering check ball and pin into housing, if no relief valve is present.
21. Lubricate and install a new o-ring seal in the groove in the housing.
22. Install the wear plate and align the timing groove on plate with the timing groove on the housing.
- Note:** The holes in the wear plate are not symmetrical.
23. Install the drive, be sure the slot in the drive engages the pin.
24. Lubricate and install a new o-ring seal in the groove in the wear plate.
25. Install the gerotor and align the timing groove with the timing groove in the wear plate.
26. Lubricate and install a new o-ring seal in the groove in the gerotor ring.
27. Lubricate and install a new o-ring and seal ring in the groove in the gerotor star.
28. Install the spacer.
29. Install end cap and four cap screws. Align timing groove on endcap with timing groove on gerotor. Tighten cap screws, in a crisscross pattern, to 25 -31 Nm [225-275 lb-in].
30. Install the relief valve/check if present. Use a new o-ring and tighten the plug to 17 Nm [150 lb-in].
31. Remove the SCU from the vise.
32. Check SCU and confirm all timing grooves are in line.
- Note:** If timing grooves are not aligned properly, SCU will not function.

2-Piece Shaft Seal Assembly Installation

2-Piece Shaft Seal Installation

For installation of
O-Ring 4999650-001 and
Seal 4998312-001

1. Place housing on a flat work area as shown in figure 13.
2. Lubricate seal and o-ring with hydraulic oil before installation.
3. Align sleeve with housing bore (figure 13).
4. Insert sleeve into housing bore (figure 14).
5. Place o-ring on plunger (figure 15).
6. Align seal with plunger cross section "L" shape of seal should be upside down (figure 16).
7. Push seal onto plunger. Lip of seal should be between o-ring and plunger. No gap should exist between o-ring and seal (figure 17).
8. Align plunger into sleeve until it bottoms out, rotate 1/4 turn (figure 19).
9. While holding sleeve in housing, withdraw plunger.
10. Withdraw sleeve.
11. Inspect seal installation. Seal and o-ring must both be within shaft seal counter bore of housing.

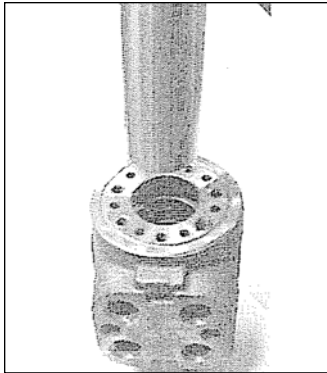
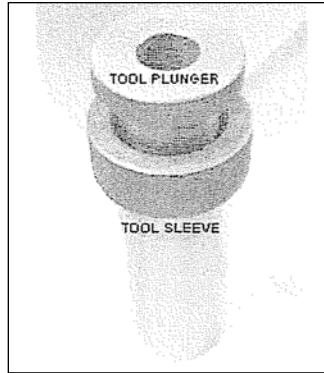

Figure 13



Tool No. 600801-001

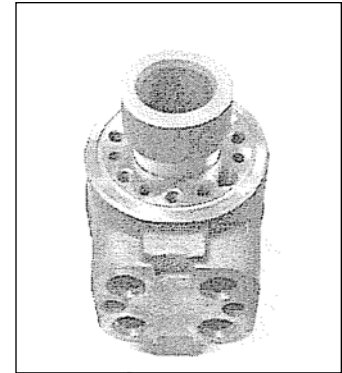

Figure 14



Figure 15



Figure 16



Figure 17

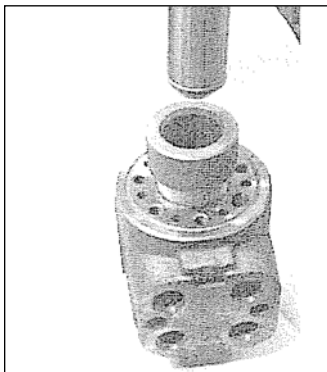

Figure 18

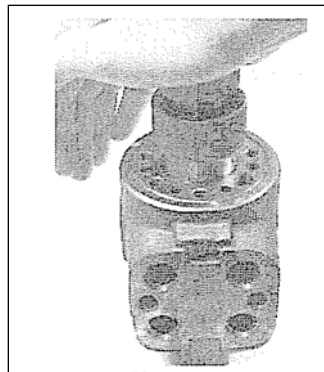

Figure 19

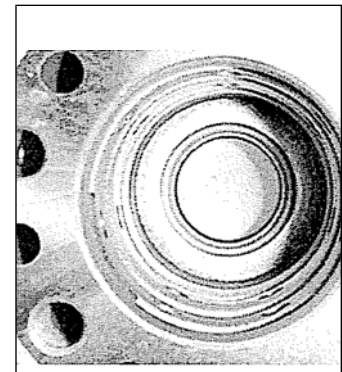

Figure 20

**How to Order
Replacement Parts**

Each Order Must Include
the Following:

1. Product Number
2. Date Code
3. Part Name
4. Part Number
5. Quantity of Parts

For more detailed Information,
contact:

Eaton Corp.
Hydraulics Division
14615 Lone Oak Road
Eden Prairie, MN 55344
www.hydraulics.eaton.com

- Specifications and
performance data, Catalog
No. C-STOV-MC001-E1

Eaton
14615 Lone Oak Road
Eden Prairie, MN 55344
USA
Tel: 952 937-9800
Fax: 952 974-7722
www.hydraulics.eaton.com

Eaton
20 Rosamond Road
Footscray
Victoria 3011
Australia
Tel: (61) 3 9319 8222
Fax: (61) 3 9318 5714

Eaton
Dr.-Reckeweg-Str. 1
D-76532 Baden-Baden
Germany
Tel: (49) 7221 682-0
Fax: (49) 7221 682-788



Char-Lynn

© 2006 Eaton Corporation
All Rights Reserved
Printed in USA
Document No. C-STCU-TS002-E1
Supersedes No. C-STCU-TS002-E
November 2006