

Vickers®

Directional Controls



Wet Armature Solenoid Operated Directional Control Valves

DG4V4-01, 1* Design; Flows to 115 L/min (30 USgpm), 315 bar (4570 psi)

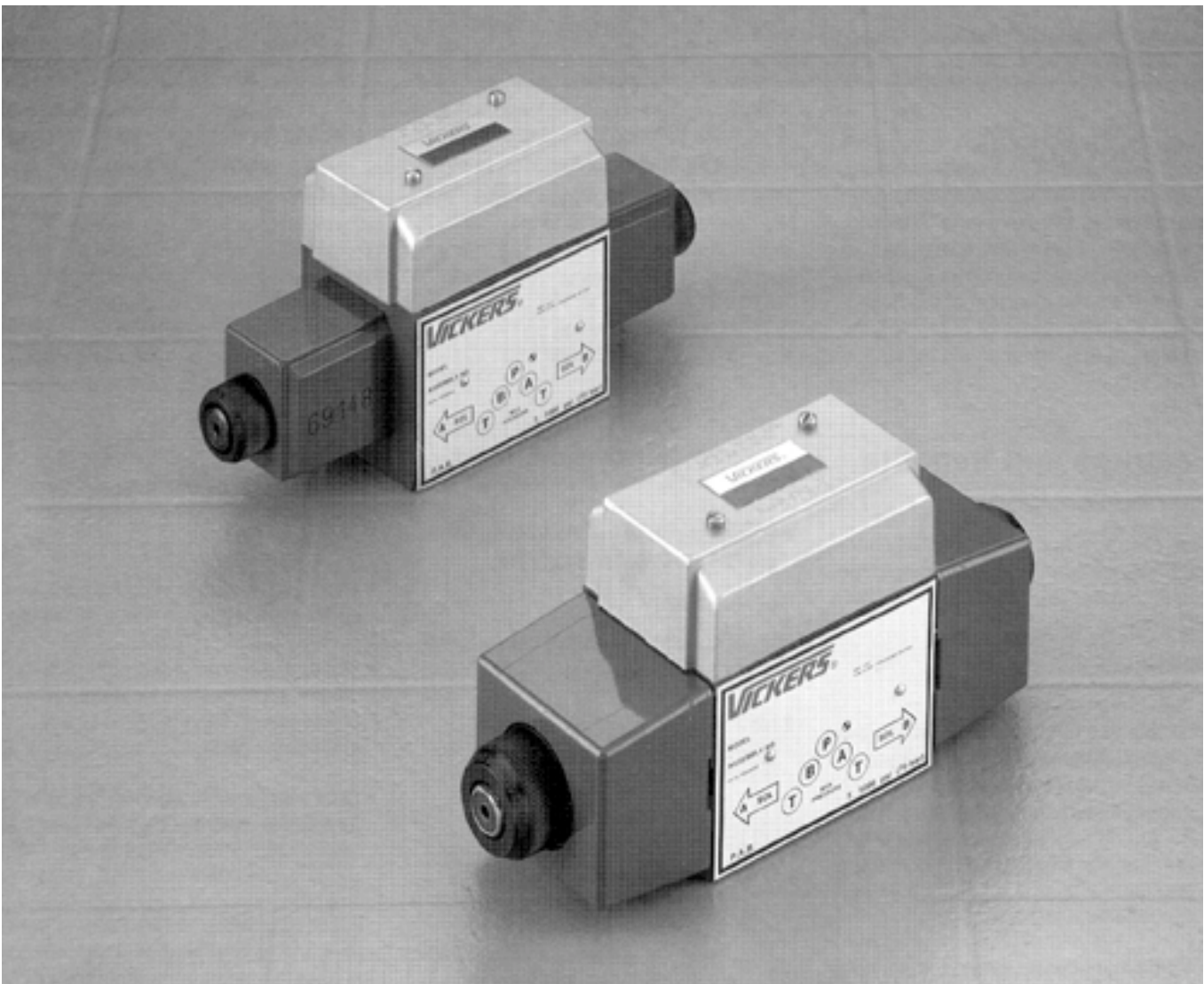

VICKERS

Contents

Introduction	2
Model Code	4
Performance Characteristics	5
Specifications	6
Flow Curves	7
Pressure Drop	8
Installation Dimensions	9
Electrical Plugs & Connectors	10
Subplate & Mounting Surface	11

Introduction

This wet armature solenoid operated directional control valve is for directing and stopping flow at any point in a hydraulic system. Its primary function is to determine the direction of the fluid flow in a work cylinder or determine the direction of rotation of a fluid motor.

These valves are designed to meet the requirements of high performance, precision industrial hydraulic systems operating at pressures up to 315 bar (4570 psi) and flows to 115 L/min (30 USgpm). They mount on the ISO size 05 mounting surface.

The performance of the most conventional solenoid operated directional valves is limited by the flow forces acting on the spool in opposition to the solenoids and return springs. Special attention is given to compensating for, or minimizing, these undesirable forces in the design of the series 5 valve.

Features and Benefits

High Performance

High pressure and flow capability with performance comparable to competitors, due to 315 bar (4570 psi) and 115 L/min (30 USgpm) ratings.

Reliability

A high margin of shifting force is available to overcome spool friction due to dirt and other contaminants. Also, a balance spool with cushioned shift means less wear and long life.

- Wet armature solenoids for quieter operation and long life with no dynamic seal leakage.
- Molded coil construction is impervious to moisture and dirt.
- Larger diameter spool combined with constant area and tangential flow passages result in low pressure drop.

- Stainless steel solenoid pin is processed hardened for long life.
- Patented detent mechanism for greater reliability and long life.

Serviceability

Plug-in coils and electrical connections simplify maintenance.

- Cartridge style manual actuators; easily replaced or exchanged for an SAE plug.

- Plug-in solenoid coil for ease of servicing can be replaced without disturbing the hydraulic system or wiring cavity.
- Two solenoid sizes to choose from for optimum performance and cost selection.
- Optional pin-type or top-side plug-in electrical connectors for easy valve replacement. Reversible to fit any installation need.
- Dual frequency (50/60 Hz) 2-wire coils for lower inventory at the OEM (optional).

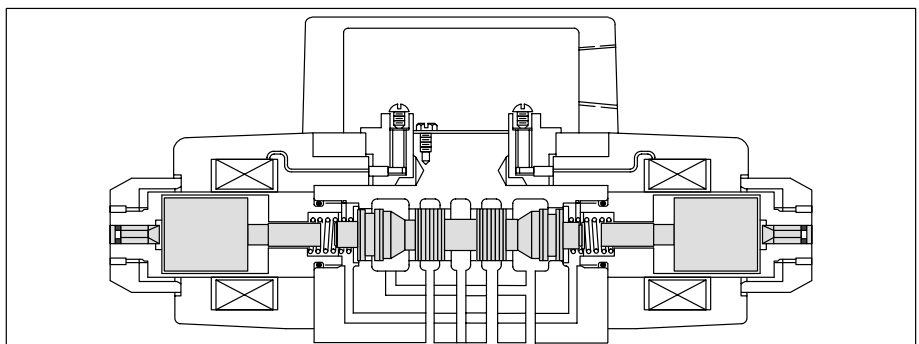

DG4V4-01, 1* Design

Optimum Performance Features

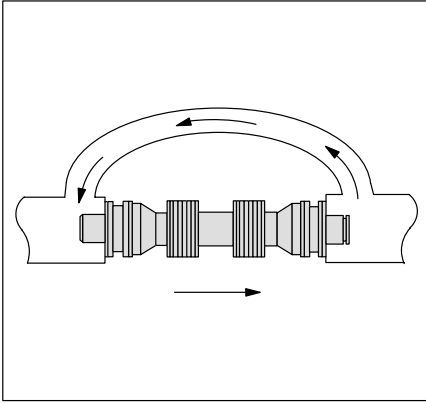

- **Spool Cushioning Passage** - Equalizes hydraulic force on ends of the spool and cushions spool shift.

When spool is shifted, the fluid displaced from one end of the spool is transferred to the other end through this passage which is designed to provide a cushioning effect and balance the spool.

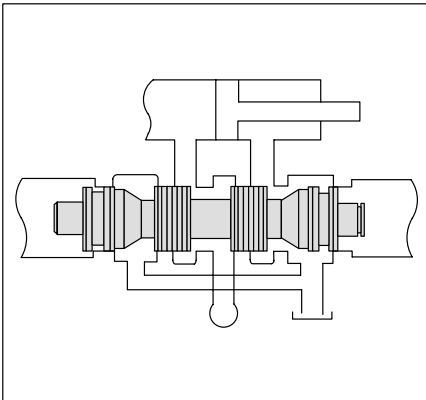

- **Spool Force-Balancing Contour** - The hydraulic unbalancing effects of fluid momentum between the cylinder and tank ports is minimized.

Flow forces that are developed at the conventional square land orifice (P to B) are partially compensated for by the force balancing contour on the outer spool lands (A to T).

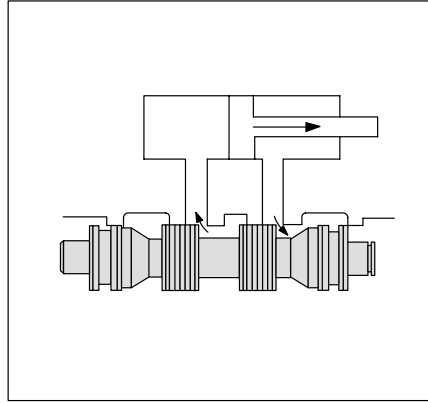

- **Spool Land Sequencing** - Accurate sequencing of land opening and closing provides maximum axial stability.

In the example above, it is important that the flow path A to T is opened before the path P to B to prevent pressure intensification which could upset axial balance and limit valve function.

- **Isolated Solenoid Chambers** - Transient pressure peaks in the solenoid to prevent solenoid tube failure are minimized.

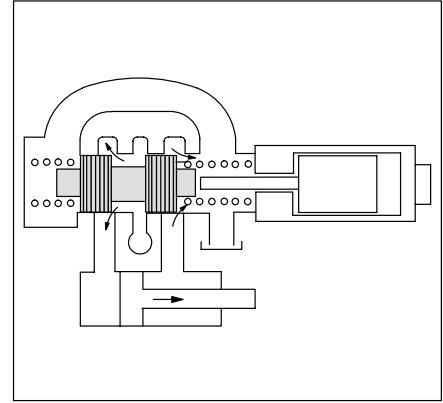

Typical 2-Land Spool

Pressure surges can occur within the armature tube of 2-land wet armature valves due to cylinder port decompression. These surges can easily exceed tube pressure rating and result in premature tube failure.

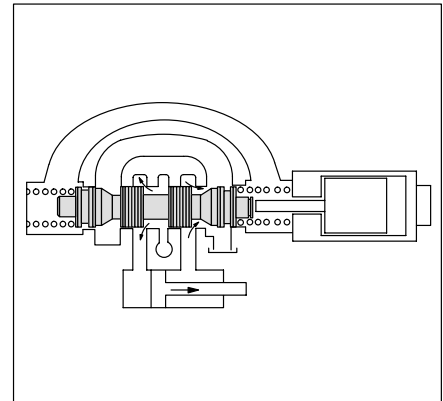

4-Land Spool

The armature tube area is isolated from the tank port area by the outboard lands on the 4-land spool. Tank port pressure surges do not reach the armature tube to cause failure.

Model Code

F* - DG4V4-01 - ** - *(L) - (Z) - (V)M - (S*) - ** - * - * - (L) - ** - *(L) - * - 1* - S*****

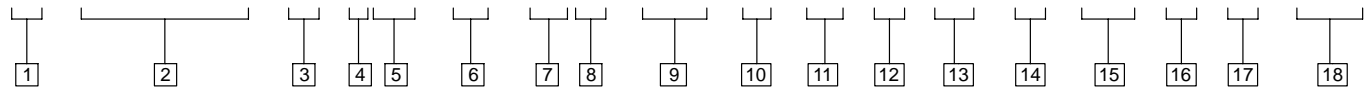

1 Special Seals

Omit if not required.

F3 - Seals for fire retardant fluids

F6 - Seals for water glycol

2 Model Series

DG4V4-01 - Subplate mounting; solenoid operated. Pressure rating 315 bar (4570 psi) for ports P, A & B.

3 Spool Type

0 - Open center (all ports)

1 - Open center (P to A & T) B blocked

2 - Closed center (all ports)

3 - Open center (P & B blocked) A to T

6 - Closed center (P blocked) A & B to T

7 - Open center (P to A & B) T blocked

8 - Tandem center (P to T) open crossover

11 - Open center (P to B & T) A blocked

22 - Closed center (two way)

31 - Closed center (P & A blocked) B to T

33 - Closed center, bleed A & B to T

4 Spool/Spring Arrangement

A - Spring offset, end-to-end

B - Spring offset, end to center

C - Spring centered

N - No spring detented

5 Left Hand Build

Omit if not required.

6 Manual Override Options

Omit if serviceable.

Z - No manual override

7 Solenoid Energization Identity

V - Solenoid "A" is at port "A" end/or solenoid "B" is at port "B" end, independent of spool type.

Omit for U.S. ANSI B93.9 standard requiring solenoid "A" energization to connect P to A and/or solenoid "B" to connect P to B, independent of solenoid location.

8 Flag Symbol

M - Electrical options and features

9 Spool Indicator Switch

S3 - Switch, wired normally open

S4 - Switch, wired normally closed

10 Coil Type

Omit for plug-in.

U - ISO 4400 (DIN 43650) mounting ♦

U1 - Connector fitted

U6 - Connector fitted with lights

♦ *Female connector to be supplied by customer.*

11 Electrical Connector

PA - Insta-plug male receptacle only

PB - Insta-plug male & female receptacle

PA3 - Three pin connector

PA5 - Five pin connector

PM4 - Mini connector

12 Housing

G - G¹/₂ BSP thread wiring housing

J - 20 mm thread wiring housing

W - 1/2" NPT thread wiring housing

13 Solenoid Indicator Lights

Omit if not required.

L - Lights fitted

14 Coil Rating (Standard Power)

Omit for low power.

A - 110V AC 50 Hz

B - 110V AC 50 Hz/120V AC 60 Hz

C - 220V AC 50 Hz

D - 220V AC 50 Hz/240V AC 60 Hz

DP - 125V DC

ED - 240V AC 50 Hz

G - 12V DC

H - 24V DC

NN - 24V AC 50 Hz

OJ - 48V DC

X - 250V DC

15 Coil Rating (Low Power)*

Omit for standard power.

AL - 110V AC 50 Hz

BL - 110V AC 50 Hz/120V AC 60 Hz

CL - 220V AC 50 Hz

DL - 220V AC 50 Hz/240V AC 60 Hz

DML - 80V DC

EDL - 240V AC 50 Hz

NNL - 24V AC 50 Hz

NVL - 24V AC 60 Hz

PL - 110V DC

XL - 250V DC

* F6 seals not available with DC low power voltages.

16 Port T Code

4 - 70 bar (1000 psi) (Low power)

5 - 120 bar (1750 psi) (Standard power)

17 Design Number

Subject to change, installation dimensions remain as shown for design numbers 10 through 19.

18 Special Features

S - Special suffix

Performance Characteristics

Maximum Pressure

Ports P, A & B 315 bar (4570 psi)*
 Port T 120 bar (1750 psi)
 (See Model Code)
 * 70 bar (1000 psi) with high water base fluids (95% maximum water content) or low watt coils.

Solenoid Energizing

Spring centered and spring offset valves will be spring positioned unless the solenoid is energized continuously. No-spring detented valves may be energized momentarily, approximately 0.15 second; when the solenoid is de-energized the spool will remain in the last position attained, provided there is no shock, vibration or unusual pressure transients.

CAUTION



Any sliding spool valve, if held shifted under pressure for long periods, may stick and not return, due to silting. Therefore, it is recommended that the valve be cycled periodically to prevent this from occurring.

Standard			
Solenoid Voltage Rating	Inrush Amps (rms)	Holding Amps (rms)	Holding-Watts
120V AC 60 Hz	3.95	0.98	37
110V AC 50 Hz	4.10	0.98	37
240V AC 60 Hz	1.97	0.49	37
220V AC 50 Hz	1.77	0.49	36
110V AC 50 Hz	3.25	0.77	30
220V AC 50 Hz	1.55	0.42	28
240V AC 50 Hz	1.55	0.42	28
12V DC	—	3.64	45
24V DC	—	1.83	45

Low Power			
Solenoid Voltage Rating	Inrush Amps (rms)	Holding Amps (rms)	Holding-Watts
120V AC 60 Hz	2.40	0.69	27.5
110V AC 50 Hz	2.40	0.78	28.5
240V AC 60 Hz	1.15	0.25	27.5
220V AC 50 Hz	1.10	0.35	28.5
110V AC 50 Hz	2.40	0.61	23
220V AC 50 Hz	1.00	0.24	23
240V AC 50 Hz	1.20	0.26	23
12V DC	—	2.33	33
24V DC	—	1.25	30

Response Time

The following response times were measured from the point of energization/ de-energization to the point of first indication of inlet pressure change.

Response up to full system pressure is dependent on the system's compressed volume and can vary with each application.

Series	Valve type	AC Solenoid		DC Solenoid	
		Solenoid Energized	Spring Return	Solenoid Energized	Spring Return
Standard	Spring centered	20 ms	50 ms	50 ms	80 ms
Low Power		20 ms	35 ms	40 ms	35 ms
Standard	Spring offset	18 ms	25 ms	50 ms	50 ms
Low Power		15 ms	35 ms	50 ms	15 ms
Standard	Detented	22 ms	—	120 ms	—
Low Power		15 ms	—	—	—

Specifications

Maximum Flow Data

Maximum recommended flow data is for AC or DC solenoids at 90% nominal voltage in a 4-way circuit with cylinder ports either looped or blocked and containing 2,5 liter (0.66 USgpm) compressed volume. Reduced performance may result when certain spools are used in 3-way circuits.

Fluids & Seals

Buna N seals are standard and are compatible with water-in-oil emulsions, high water base fluids and petroleum oils. For phosphate ester fire resistant fluids, Viton® seals must be specified. Seals for water glycol have an F6 designation. Maximum operating pressure for high water base fluids is 1000 psi.

Application Recommendations

Filtration: ISO 4406 Code 20/18/15
 Operating Temperature: 20° to 50°C (70° to 120°F)
 Fluid Viscosity: 16 - 51 cSt (75 - 250 SUS)

Valve function, symbol and recommended maximum flow (See page 7 for maximum flow curves).

Spool Type	3 Position Spring Centered (C)	Max. Flow Curve				Spool Type	2 Position Detented (N)	Max. Flow Curve			
		Standard		Low Power				Standard		Low Power	
		AC	DC	AC	DC			AC	DC	AC	DC
0		1	10	17	21	0		1	11	17	N/A
1		6	13	18	N/A	2		1	11	18	N/A
2		1	10	17	21		2 Position Spring Offset to Port A (A)				
3		4	11	18	21	0		7	14	17	21
6		3	11	18	21	2		7	14	17	21
7		1	10	17	21	22		9	16	N/A	N/A
8		5	12	20	21		2 Position Spring Offset to Port B (B)				
13		1	10	17	21	0		7	14	17	21
33		2	11	18	21	2		8	15	19	21
						22		9	16	N/A	N/A

Flow Curves

Maximum Flow Curves

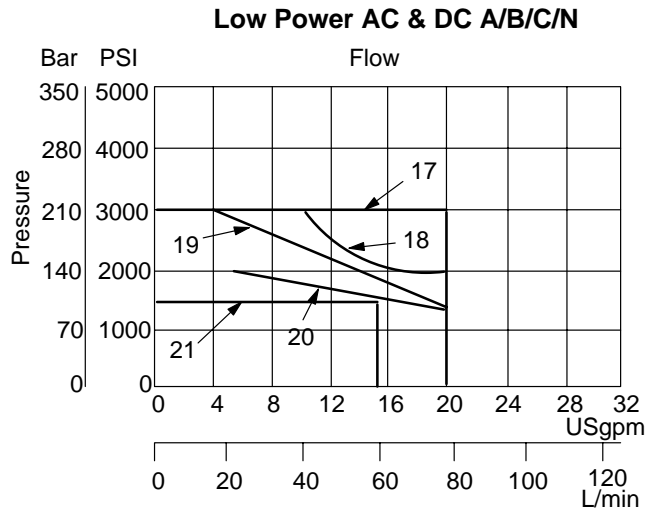
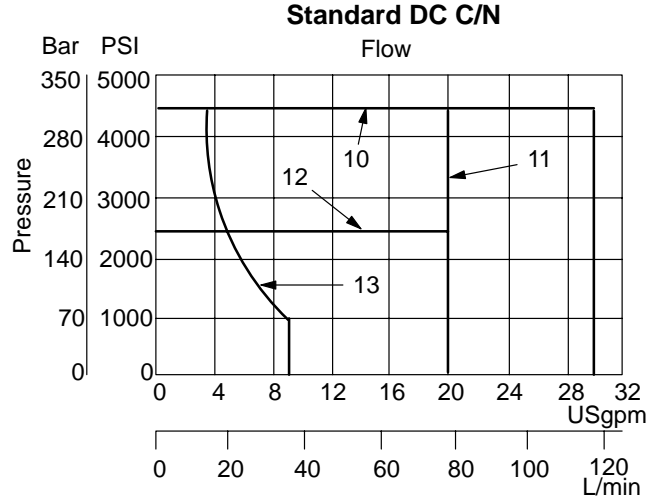
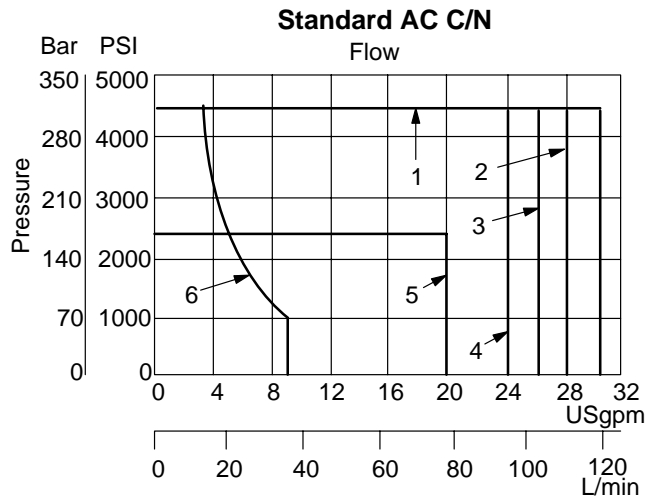
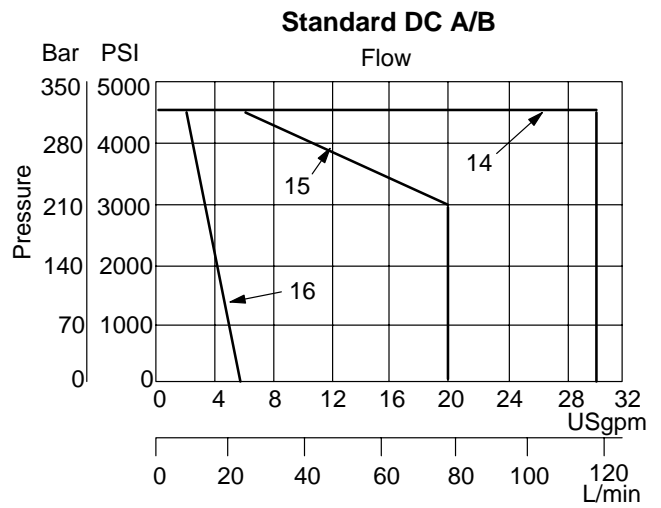
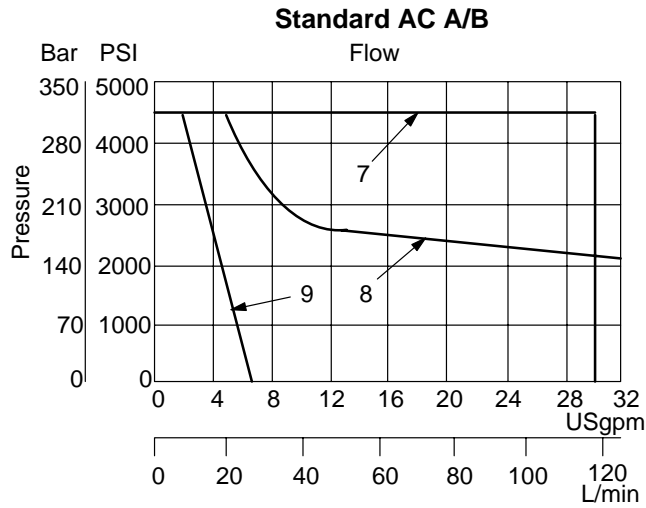

Pressure Drop

Pressure drops in offset positions except where otherwise indicated.

Spool code	P to A	P to B	A to T	B to T	P to T
0	1	1	1	2	1
1	3	4	1	6	4
2	4	4	2	3	—
3	4	4	1	3	—
6	4	4	1	2	—
7	1	1	4	6	—
8	7	7	4	4	3
11	4	3	6	1	—
22	4	4	—	—	—
31	4	4	3	1	—
33	4	4	3	3	—

For other viscosities, pressure drops approximate to:

Viscosity cSt (SUS)

14	20	43	54	65	76	85
(17.5)	(97.8)	(200)	(251)	(302)	(352)	(399)

% of ΔP

81	88	104	111	116	120	124
----	----	-----	-----	-----	-----	-----

A change to another specific gravity will yield an approximately proportional change in pressure drop.

The specific gravity of a fluid may be obtained from its producer. Fire resistant fluids usually have higher specific gravities than oil.

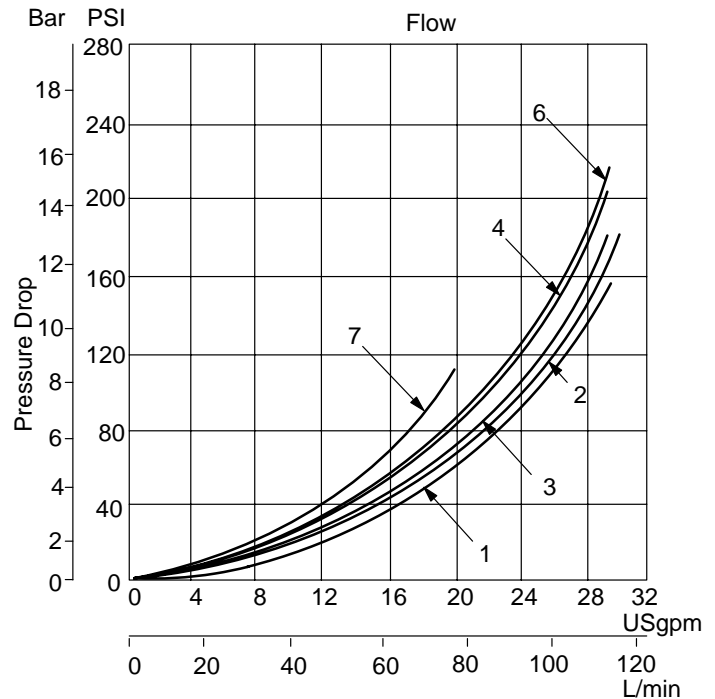

Drain

On 2-way valves, "T" is the drain and must be connected to the tank through a surge-free line, so there will be no back pressure at this port.



CAUTION

Surges of oil in a common line serving these and other valves can be of sufficient magnitude to cause inadvertent shifting of these valves. This is particularly critical in the no-spring detented type valves. Separate tank lines, or a vented manifold with a continuous downward path to tank are necessary. Consult your Vickers representative for instructions.

Installation Dimensions

Standard Conduit Box & 'PB' Insta-plug

3rd angle projection 

Electrical Current 46,8 (1.84) AC
 Signal Light ("Lights" & "PB") 87,4 (3.44) DC
 2 places Sol. A Light

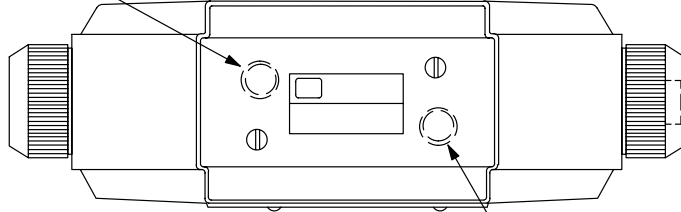

← Clearance Required for Coil Removal (Both Ends)

"G" - BSP
 "J" - 20mm thread
 "W" - 1/2" NPT
 Connection Box
 May be rotated 180°

Manual Operating Pin (Both Ends)

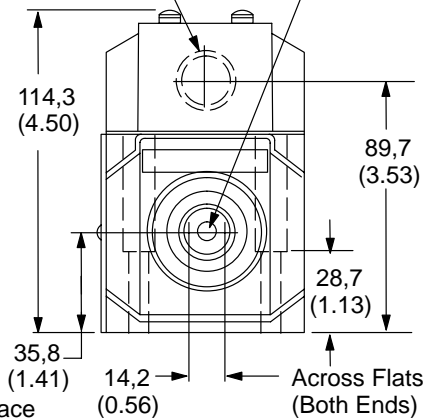
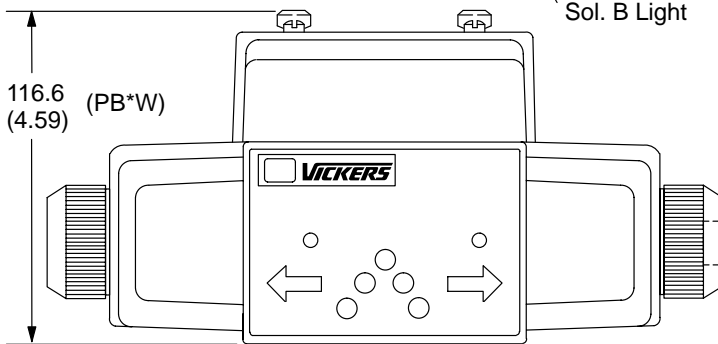

4-Valve Mounting Holes
 For Socket Head Cap Screws
 1/4-20x1-1/2 or M6x40 Metric
 SAE Grade 8 or Better, Metric Grade 10.9
 Torque 12-15 N.m (110-130 lb. in.)

NFPA D02 Mounting Surface
 (ISO 4401-AC-05-4-A)

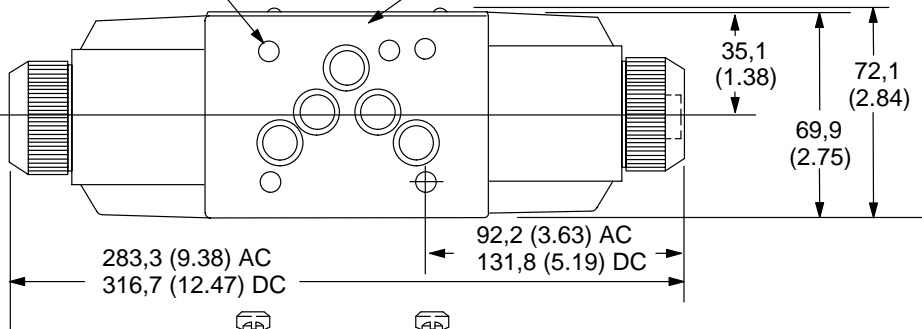

S3, S4 Switch

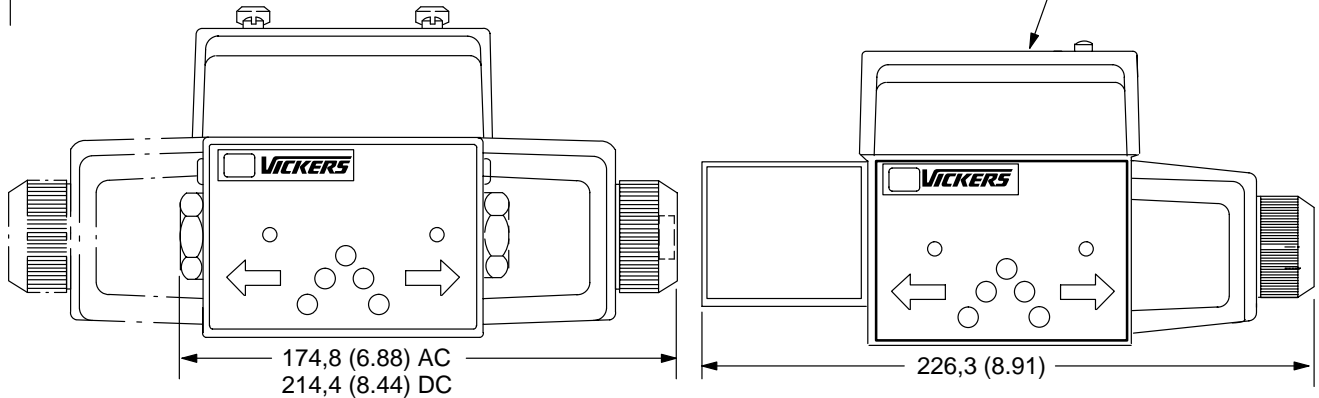

Electrical Plugs & Connectors

'L' Low Power Option

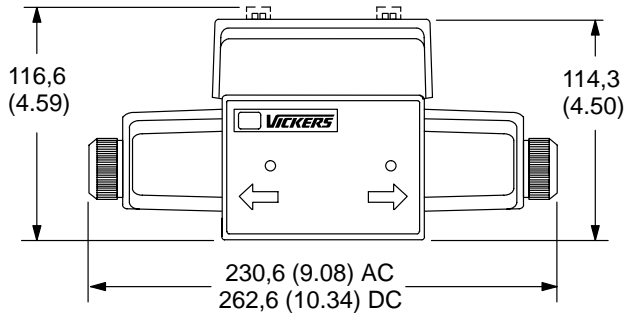

'U' DIN 43650 Connector* Option

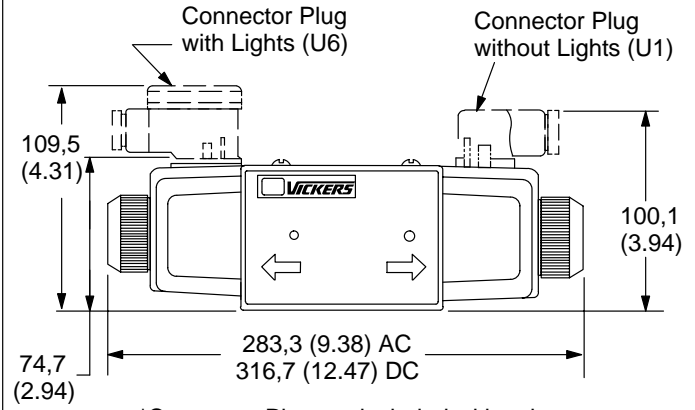

'PA'

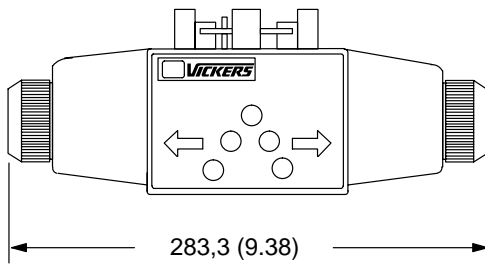

Connector Option, Pin Type 'PA3'/'PA5' (NFPA T 3.5.29) PM4 (SAE H1738-2)

Single Solenoid Valve (PA3)

Double Solenoid Valve or Optional Single Solenoid Valve (PA5)

Double Solenoid Valve or Optional Single Solenoid Valve (PM4)

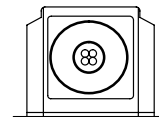
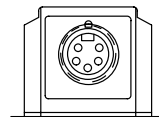
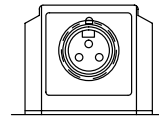

Number of Solenoids	Number of pins	Option Code
Single	3	PA3
Single or Double	5	PA5
Single or Double	4	PM4

Subplate & Mounting Surface

Millimeters (inches)

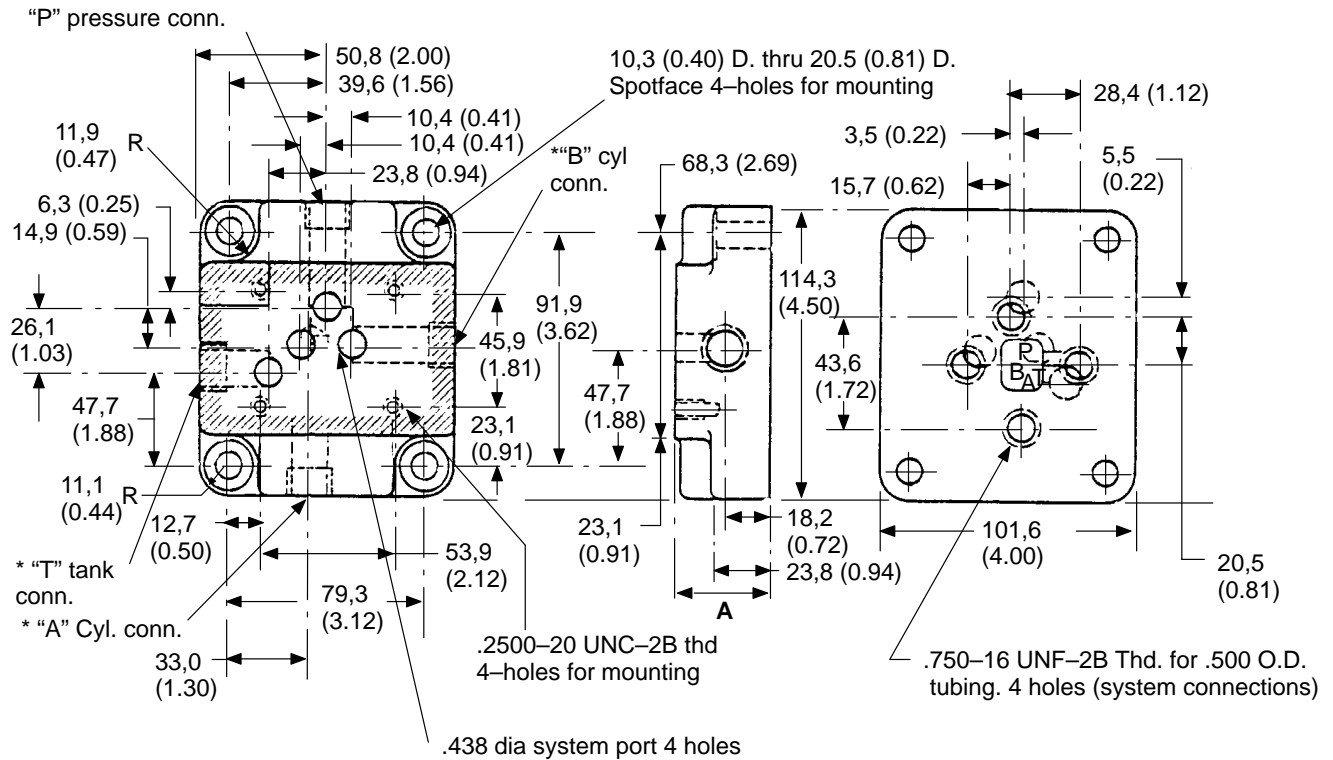

*Ports on model DGSME-01-20-T8 only

Model	Dimension "A"
DGSM-01-20-T8	31,75 (1.25)
DGSME-01-20-T8	38,10 (1.50)

When subplate is not used, a machined pad (as indicated by subplate shaded area) must be provided for mounting; pad must be flat within 0.0127 mm (.0005 inch) and smooth within 1.6 μ m (63 microinch).

Bolt Kits

Bolt kits include 4 directional valve mounting bolts and are ordered separately.

Note

Metric grade 10.9 (SAE Grade 8) mounting bolts required.

Model Codes	Sizes	Thread
BKDG01-633	1/4-20-11/2	Inch
BK855993M	M6x1x40	Metric

Fluid Cleanliness

Essential information on the correct methods for treating hydraulic fluid is included in Vickers publication 561 "Vickers Guide to Systemic Contamination Control" available from your local Vickers distributor or by contacting Vickers, Incorporated. Recommendations on filtration and the selection of products to control fluid condition are included in 561.

Recommended cleanliness levels, using petroleum oil under common conditions, are based on the highest fluid pressure levels in the system. Fluids other than petroleum, severe service cycles, or temperature extremes are cause for adjustment of these cleanliness codes. See Vickers publication 561 for exact details.

Filtration Requirements

20/18/15

Information contained in this catalog is accurate as of the publication date and is subject to change without notice. Performance values are typical values. Customers are responsible for selecting products for their applications using normal engineering methods.

Eaton Hydraulics

15151 Highway 5
Eden Prairie, MN 55344
Telephone: 612 937-7254
Fax: 612 937-7130
www.eatonhydraulics.com

46 New Lane, Havant
Hampshire PO9 2NB
England
Telephone: (44) 170-548-6451
Fax: (44) 170-548-7110



Quality System Certified
Products in this catalog are
manufactured in an
ISO-9001-certified site.

