

Vickers®

Valves



CM2, CM11, RM3 & FM3 Control Valves

For Mobile Equipment

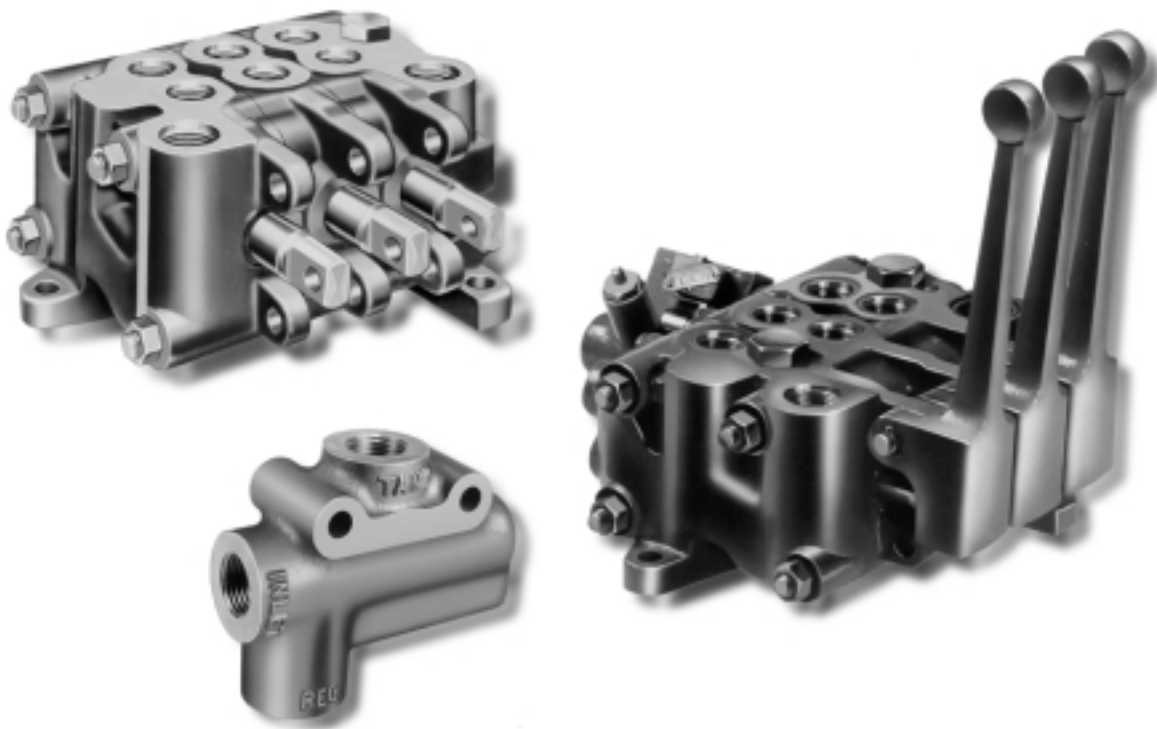

Introduction

The directional valves described in this booklet are more than just directional valves -- they are hydraulic control systems. Their function is to control direction of flow, rate of flow and pressure.

Through the use of various valve circuitry, logic circuitry can be provided

for automatic sequencing operations. Sequencing operations can be either pressure or position-actuated. Vickers valves are also designed to permit the operation of many functions from a single pumping source. These and the many other features provide the "building blocks" for a control system for any piece of mobile equipment.

Vickers has the worldwide facilities and skilled personnel to give you quality products, prompt delivery, plus application and service assistance. You can depend on Vickers for the finest hydraulic products and service.

Contents

Multiple Section Directional Valves

CM2 and CM11 Series

General Description	3
Benefits	4
System Relief Valve	5
Cylinder Port Valving	5
Inlet Sections	5
Outlet Sections	8
Narrow Bypass Sections	9
Spools	9
Spool Symbols	10
Spool Orientation	10
Spool Detents	10
Detent Conversion Kit	10
Optional Centering Springs	10
Hydraulic Actuators	10
Electric Switch	11
Electric Switch Conversion Kit	11
Two-pressure System	11
Lever Linkage Adapter	11
Lever Kits	12
Mixture of Port Sizes	12
Dust Covers	12
Viton Seals	12
Specifications	12
Typical Performance	12
Performance Data Curves	13
Installation Dimensions	
CM2 Series	14
CM11 Series	18
Model Codes	
CM2 Series	22
CM11 Series	23

Pressure and Flow Control Valves

RM3 and FM3 Series

Description	24
Performance Curves	24
Installation Dimensions	25
Model Code	26

Application Guidelines	26
------------------------	----

Multiple Section Directional Valves

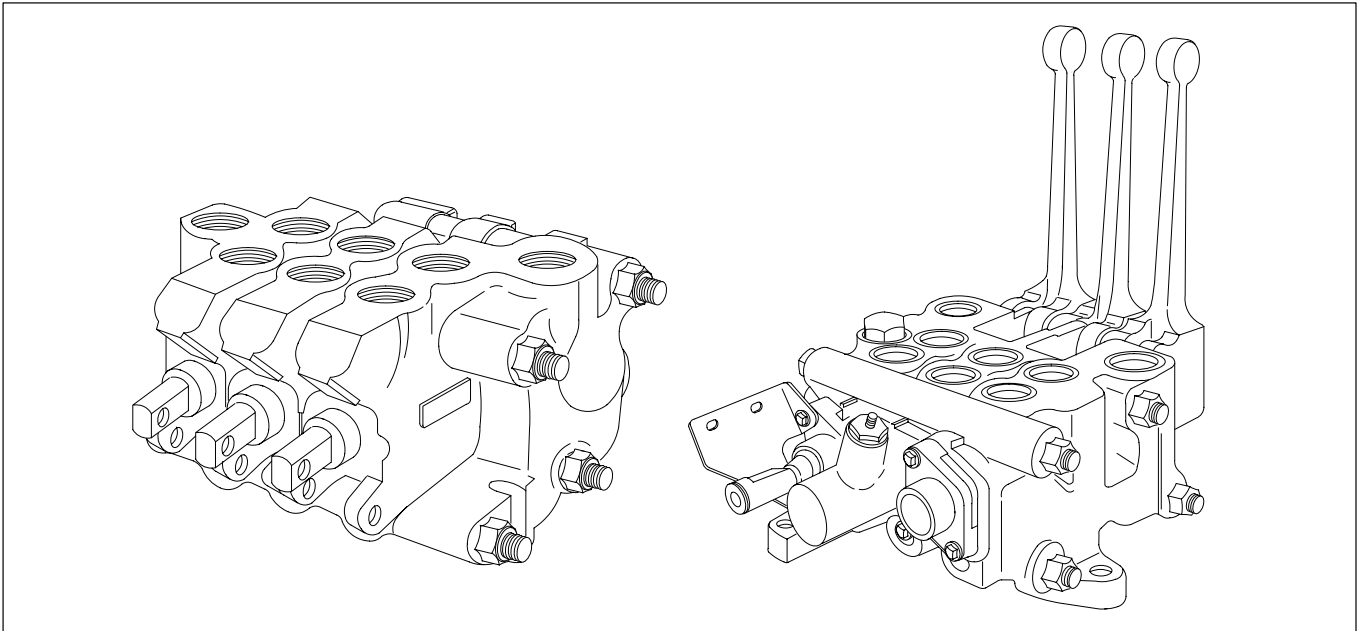

General Description

These manually and hydraulically actuated, spring centered, spool type valves are designed for pressures up to 210 bar (3000 psi) and flows up to 265 l/min (70 USgpm). They are comprised of sections that are internally connected to common pressure and tank return

passages. Seals between the sections seal the connecting passages, and the sections are held together by studs and nuts.

Valve sections are available as assembled banks, and as separate

sections for customers to assemble into banks or to add to or change the functions of a bank. The following illustration shows the construction and assembly of a three-section valve.

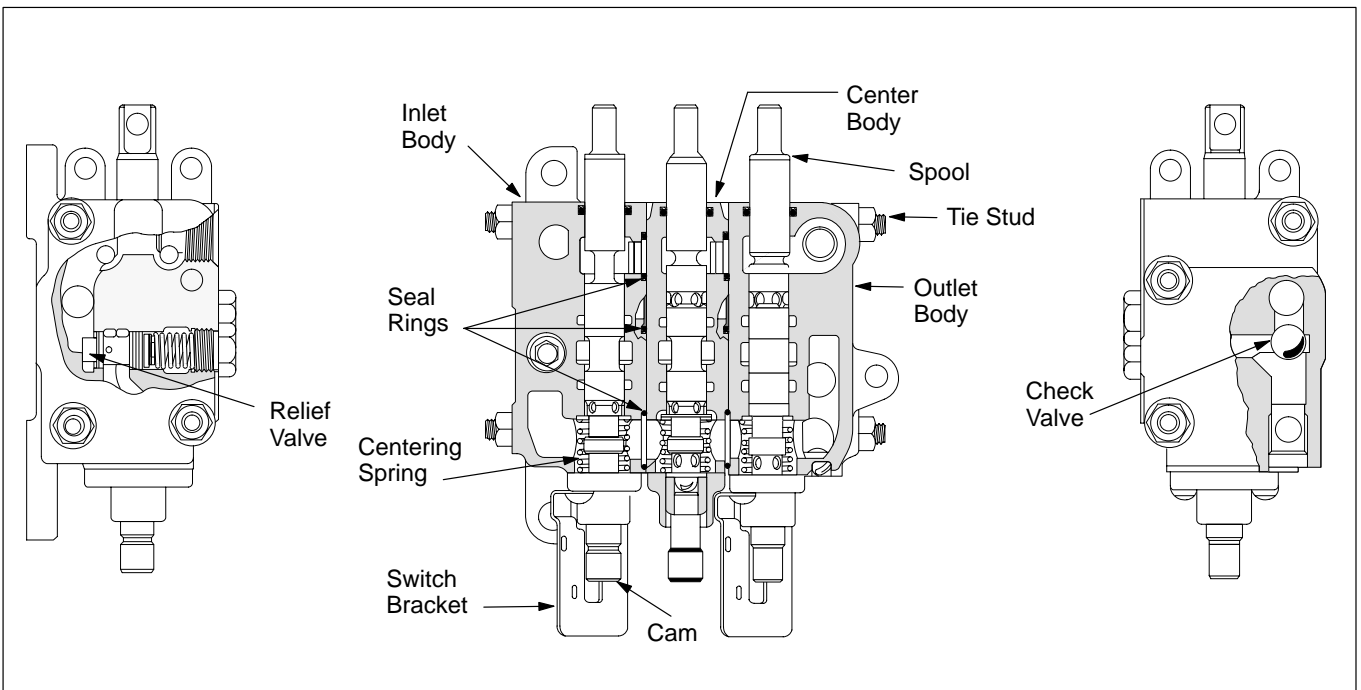

Multiple Section Directional Valves

End sections of multiple-spool valves contain the inlet or outlet porting and a spool. Eight spools can be added between end sections for a maximum of ten operating sections per valve bank.

For single-spool valves the spool is located in the inlet end section, and a no-spool outlet plate is used.

The following illustration shows the inlet and outlet ports and the bypass, pressure and tank passages of a typical three-section valve. The pressure passage carries fluid to cylinder ports when the spools are shifted. The bypass passage permits flow directly to the outlet when the spools are not being operated. The tank passage also carries fluid to the outlet; either return flow from the cylinder ports or fluid diverted past the flow control and relief valve.

Spools are shown in the centered or neutral position. Under these conditions, fluid in the pressure passage is blocked from cylinder ports by the spool lands. Flow through the valve is through the bypass and tank passages to the outlet.

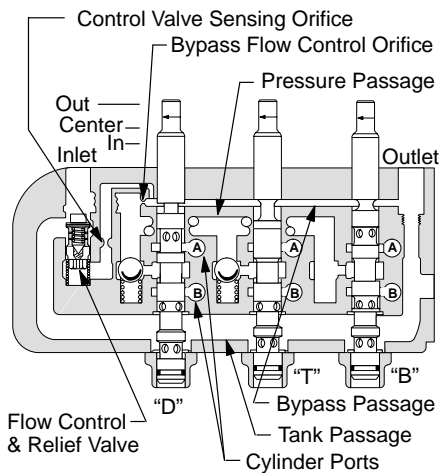

When a spool is shifted, flow is as described in the "spools" section on page 9.

All sectional valves have internal parallel circuitry. All pump flow can be used for any one work function. If two or more spools are shifted simultaneously, flow will go to the function requiring the lowest pressure. Flow can be controlled to multiple functions by metering the spools.

Valve banks can be connected in parallel or series-parallel. Spools in the second bank can be operated when spools in the first bank are in the neutral or operating position.

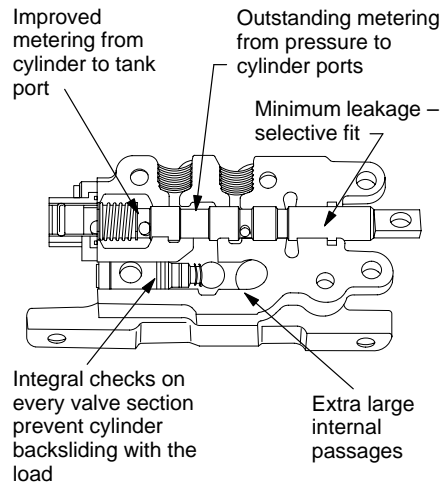

Each valve section, except those with a "B" spool, includes a load-drop check valve to prevent a load from dropping when an operating spool is shifted. A load-drop check can be provided in "B" spool sections for special applications.

Benefits

Smooth Operation – Vickers manually operated sectional valves offer absolute smoothness both in raising and lowering loads. In addition to outstanding metering from pressure to cylinder ports, they have equally precise metering capability from cylinder to tank port.

High Work Capacity – Little horsepower is consumed in the valve due to low pressure drop. On many engine-powered vehicles this gives the potential for low heat rise from valve hydraulic flow losses in areas where excess heat may already be a problem.

On electric battery-powered vehicles, valuable ampere hours are saved because energy wasted through heat loss is reduced. More fluid power is available to perform work.

Installation and Service Flexibility

Multiple section design provides installation and service flexibility. Valves can be maintained or modified readily and at low cost in the field. Three-point mounting aids installation stability when the valve is mounted on an irregular surface.

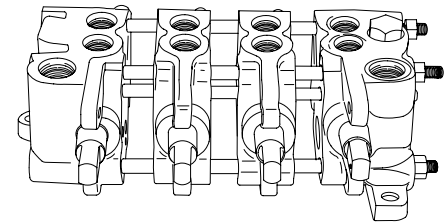

Versatile Sectional Design

High Strength Castings

Cast iron valve bodies reduce deflection so that even under the most arduous operating conditions there is no spool bind from pressure. Internal passages are shell-cored to provide streamlined hydraulic passages for minimum pressure drop.

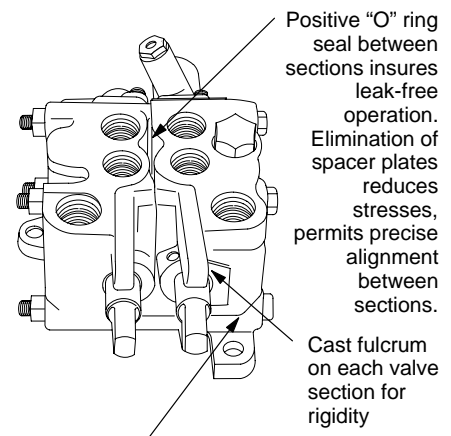

High strength iron casting reduces internal stresses, insures smooth operation of spool

Integral System Protection

An integral cartridge type relief valve is provided in the valve inlet for system protection. Pressure settings are preset to your specifications to provide tamper-free installations.

Multiple Section Directional Valves

System Relief Valve

“R” and “K” inlet sections are provided with an integral, cartridge type relief valve for system protection. Cracking pressure is preset to your requirement. Settings are available from 35-210 bar (500-3000 psi) in increments of 17 bar (250 psi).

Tamperproof relief valve preset from 35-210 bar (500-3000 psi), in 17 bar (250 psi) increments

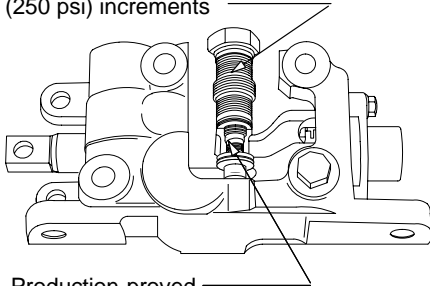

Production-proved, pilot operated relief valve

Externally Vented System Relief Valve

– This CM11 valve option consists of a tapped hole in the SAE plug which holds the relief valve in its bore. This feature thus provides a means for remotely diverting pump flow to tank to unload the system.

Externally Adjustable System Relief Valve

– An externally adjustable system relief valve is available for CM2 and CM11 valves. This option is provided by adding a second, externally adjustable pilot stage to control the system pressure at which the main relief shifts and directs pump flow to tank. The second pilot stage is adjustable to control system pressure up to 17 bar (250 psi) below the main relief setting.

In effect, the standard relief valve pilot stage acts as a safety limit. The operator cannot exceed the vehicle’s maximum intended load rating. The optional adjustment feature, however, allows simple adjustment of system pressure after the valve is installed in the vehicle and under actual load-lifting conditions. It also permits adjustment for minimum pressure to meet vehicle ratings, for example, providing a means to obtain the lowest possible current draw on electrically powered lift trucks. Refer to the following diagram.

Cylinder Port Valving

CM2 directional valves are available with any combination of cylinder port prefill check or relief valves as shown in the model code on page 22. The port relief valves prevent excessive pressure in cylinder or actuator lines when the directional valve spool is in the neutral position. The port also acts as an anti-cavitation and prefill check valve.

When pressure in the cylinder port is less than pressure in the return line, the check valve allows return oil to replenish the system. When cylinder port pressure becomes greater than return line pressure, the check valve prevents system oil from escaping to tank. Relief valve pressure settings are available from 52-240 bar (750 to 3500 psi) in increments of 17 bar (250 psi).

Inlet Sections

“R” Inlet Section – This inlet section incorporates Vickers partial flow bypass feature. The bypass allows the addition of operating sections to the valve without a significant increase in the pressure-to-tank pressure drop. “R” sections also provide a controlled

carryover flow source for application with separate auxiliary components in series circuits from the main valve. Carryover flow is approximately 26 and 95 l/min (7 and 25 USgpm) for CM11 and CM2 valves respectively.

“J” Inlet Section – The operation of this CM11 valve section is the same as that of the “R” inlet section except the bypass flow is approximately 34 l/min (9 USgpm). The “J” section thus allows the use of higher volume components downstream from the valve than does the “R” section.

“K” Inlet Section – In CM2 valves, this inlet section provides full flow carryover for use in circuits where total pump delivery is required for downstream functions.

In the CM11 “K” section, the inlet flow should not exceed 57 l/min (15 USgpm).

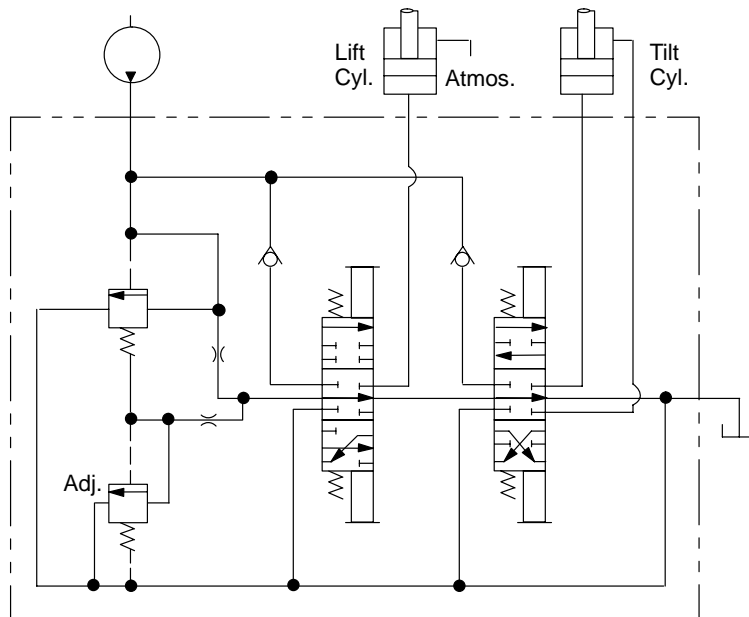

Multiple Section Directional Valves

“K” Section with Relief Valve

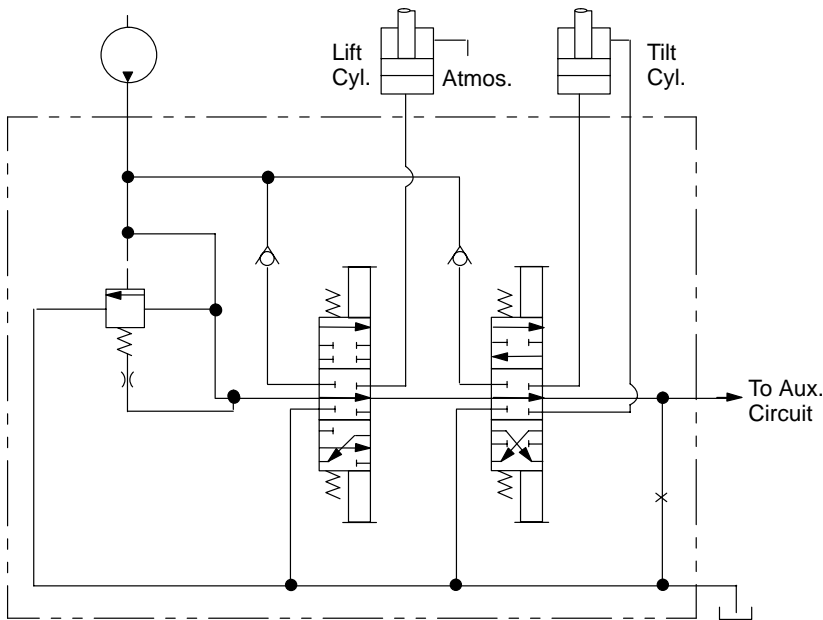

“K” Inlet Section Without Relief Valve (“K00”) – Relief valve and flow control action is eliminated within the directional valve by replacing the

hydrostat and spring with a plug. However, an external relief function must be provided when using valves with this option.

“K” Section without Relief Valve

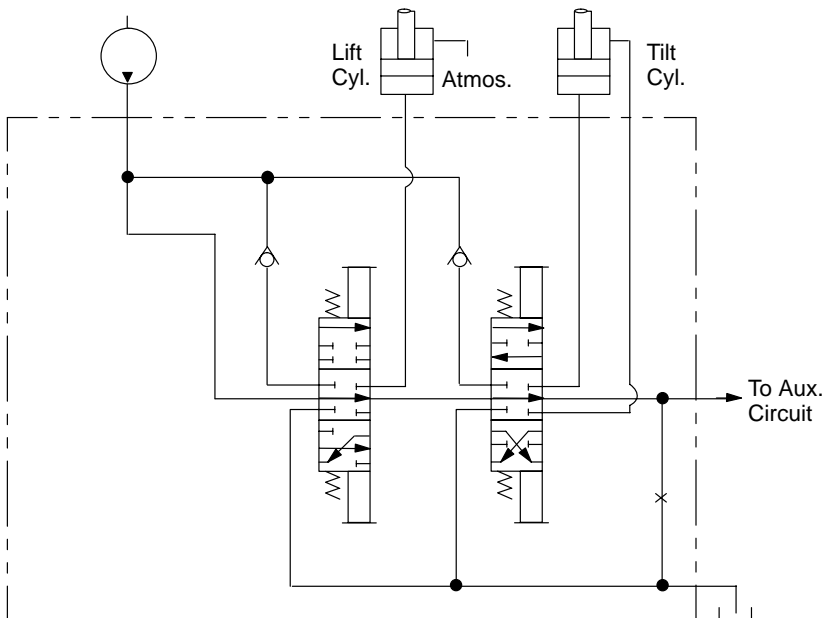

Multiple Section Directional Valves

Inlet Sections for Controlled Flow to Cylinder Port – This feature can be provided in the “R”, “J” and “K” inlet sections of CM11 valves to control the maximum speed of cylinder or motor operations. The integral system relief valves is utilized as a flow control valve

when a main valve spool incorporating the controlled flow function is operated. A fixed or adjustable orifice, (1) in the following circuit diagram, is added in the controlled flow (tilt) section. The low pressure side of the orifice is

communicated back to the relief valve, thus providing the pressure compensated, by pass flow control. All sections downstream from a controlled flow section utilizing a fixed orifice will be limited to the flow provided by the orifice sizing.

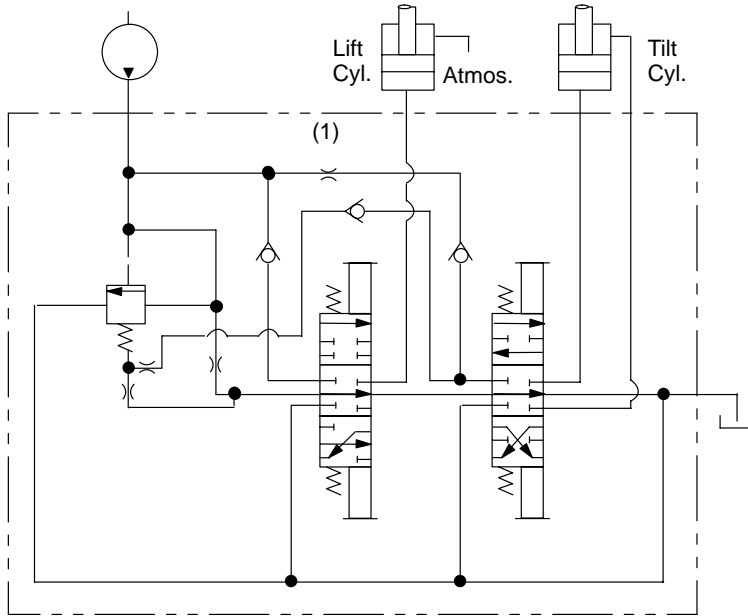

“F” Inlet Section – This section is normally used as the inlet section of a second valve bank in a parallel circuit. The “F” section provides full flow for second-bank operation when first-bank spools are in neutral or in an operating position.

This section has two separate inlet ports (top and side). A plug within the side port separates bypass flow from main valve spool flow.

The “F” section in a second valve bank is dependent on the first valve bank for carryover flow and relief valve protection.

“F” Inlet Section for Parallel Operation

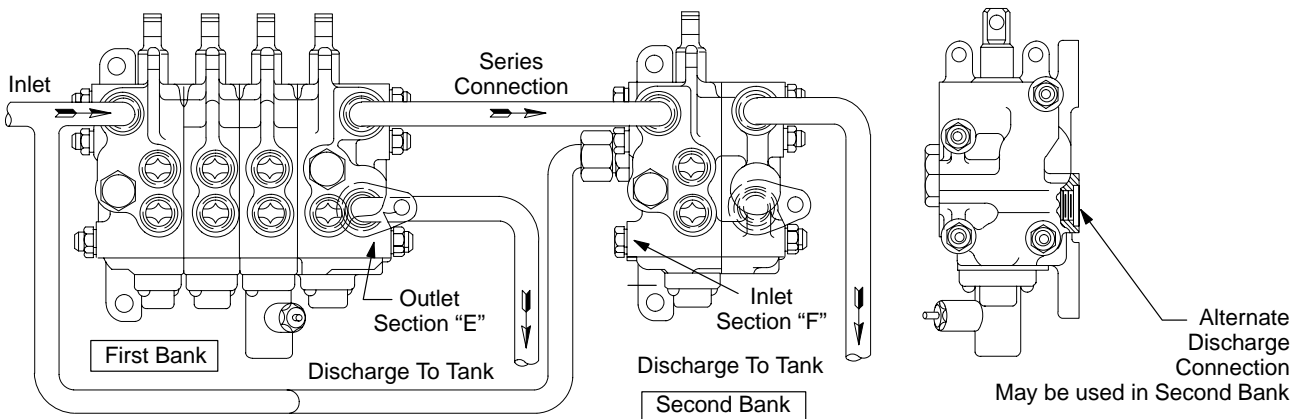

Multiple Section Directional Valves

Inlet Section for Closed Center System – CM11 valves can be provided with an inlet body with a blocked bypass passage and integral

system relief valve for closed center or constant pressure systems. This feature is denoted in the following typical circuit by the “X” in the bypass

line and may be ordered by using a “001” suffix following the valve design number in the model code.

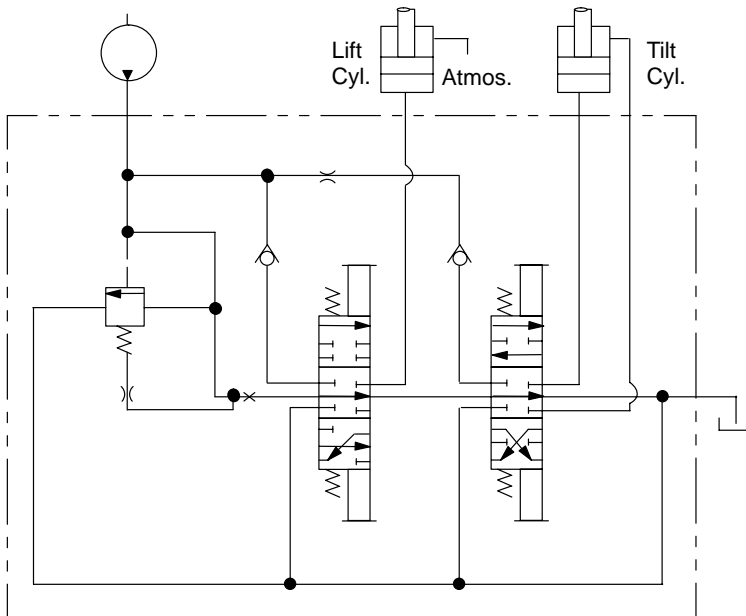

Typical circuits utilizing this option would use pressure compensated pumps or unloading valve-accumulator systems.

This option is also used on rock drill applications where the hydraulic pump is driven by an air motor. Centering the valve causes a pressure build-up and a stall condition in the air motor, thus conserving air pressure.

A closed center inlet body without a relief valve can be ordered for CM11 valves by specifying a “G” inlet body in the valve model number, in which case the “001” suffix described above is not required.

Outlet Sections

“L” Outlet Section – This standard outlet section is provided as an operating section (with spool) for multi-spool valves, or as a non-operating section (without spool) for single-spool valves.

A special non-operating outlet section can be provided which allows an operating section to be installed at the end of a multiple-spool valve bank, without disconnecting plumbing of existing sections. This option increases the valve length by 3/4 of an inch, and special tie bolts must be used.

The standard “L” section for CM2 valves has three outlet ports; top, bottom (manifold) and side. The “L” section for CM11 valves has a top and a bottom outlet port. All valves can be provided with removable, permanent type plugs or plates on the outlet port(s) that will not be used.

Standard “L” sections can be field-converted to “E” outlet sections. For CM2 valves, this is done by installing a 3/4” NPTF pipe plug (Part No. 7078) through the side outlet port. For CM11 valves, a 3/8” NPTF pipe plug (Part No. 7076) is installed through the top outlet. See following description of “E” outlet section.

“E” Outlet Section – An “E” section is a standard “L” section with an internal pipe plug that separates the bypass passage from the tank passage. On CM2 valves, the plug is located within the side outlet port. On CM11 valves, the plug is located within the top outlet port.

“E” sections are used for connecting one valve bank to a second valve bank in a parallel or series-parallel circuit. Bypass flow from the first bank is made available for operating the second bank by connecting the internally plugged outlet of the first bank to the inlet of the second bank.

Cylinder exhaust oil from the first bank is returned to tank through the bottom outlet of CM11 “E” sections, and through either the top or bottom outlet of CM2 “E” sections. The unused outlet on CM2 sections must be plugged.

Multiple Section Directional Valves

“E1” Outlet Section – This section is available on CM11 valves only. It is a standard “E” section with an additional

outlet port in its top face for connecting return oil to tank. This port can be used instead of the bottom outlet port when

connecting valve banks in a parallel or series-parallel circuit.

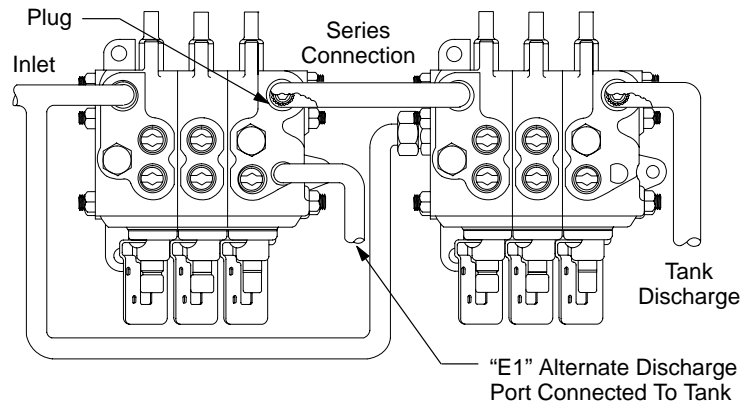

Narrow Bypass Sections

CM11 valve sections are available for use in low volume circuits of approximately 19 l/min (5 USgpm). Their use provides better metering characteristics in low volume ranges. Slight spool movement stops or starts flow.

Spools

Various spool designs are available to meet a broad range of application requirements. Different spools can be combined in a valve bank to handle a variety of operations. All spools are plated for protection against corrosion.

“B” Spool – This spool is normally used to direct flow to a reversible rotation, hydraulic motor. Cylinder ports remain partially open in the neutral position to allow oil flow between motor and reservoir. The “B” spool is normally provided without a load-drop check valve but, for special cylinder applications, it can be provided.

“T” Spool – This spool directs flow to only one end of a cylinder, as in the example of the lift mechanism on a lift truck. Return flow is from the same end of the cylinder and relies on gravity or mechanical means.

“W” Spool – This spool is for applications whereon equipment linkage requires operation in reverse to that of the single-acting “T” spool.

“W3” Spool – This CM11 valve spool is normally used in the basket of a utility truck.

The “W3” spool is used in a valve bank which requires shifting the “W3” spool in conjunction with any other spool. This provides a safety interlock in that both of the operators hands are required to operate the valve.

“D” Spool – This spool directs flow to either end of a double acting cylinder. Flow from the end not under pressure is returned to tank via internal coring of the valve sections.

“C” Spool – This is a double acting spool with a “float” position. Float is the extreme-out spool position in CM2 valves, and is an intermediate position in CM11 valves.

This spool is held in the float and neutral positions by a detent. CM2 spools are spring centered to neutral from the “in” or “out” position only. CM11 spools are spring centered to neutral from the “in” position only.

Both cylinder ports of CM2 valves are open to tank in the float position; both ports are blocked in the neutral position. Both cylinder ports of CM11 valves are also open to tank in the float position, but in the neutral position, port “A” is open to tank and port “B” is blocked.

“A6” Spool – This counterbalance spool is available for CM11 valves and is normally used to control the tilt function of a lift truck. The counterbalance feature is to prevent the forks from tilting forward faster than the pump can supply oil and prevent tilt.

When there is no pressure within the pressure passages, an inner spool prevents flow from cylinder port “A” to tank. When passage pressure rises to about 14 bar (200 psi), the force exerted on the differential area of the small inner spool forces it against a spring and allows oil to flow from port “A” to tank. With this valve arrangement, port “A” would normally be connected to the rod end of the tilt cylinders. Port “B” of the “A6” spool does not restrict flow from cylinder to tank.

Multiple Section Directional Valves

Spool Symbols

“B” Spool

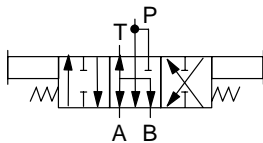

“B” Spool with Check Valve (CM11 only)

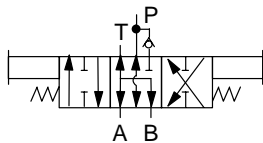

“T” Spool

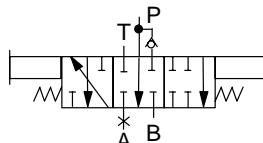

“W” Spool

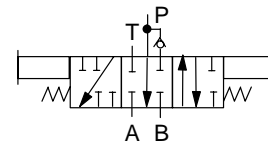

“W3” Spool (CM11 only)

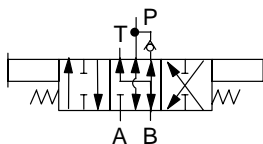

“D” Spool

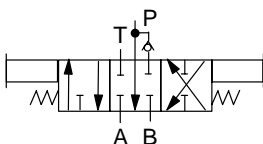

“C” Spool (CM2 only)

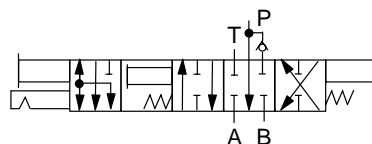

“C” Spool (CM11 only)

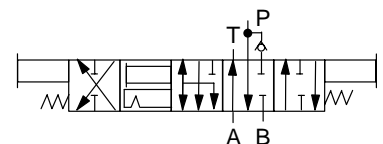

“A6” Spool (CM11 only)

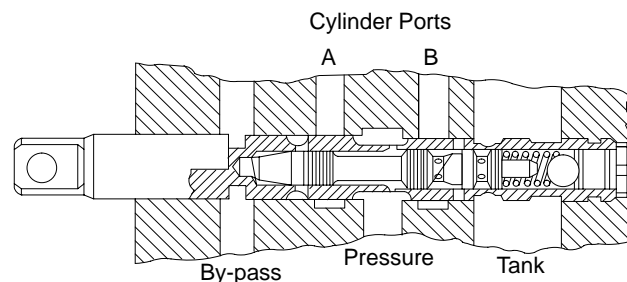

Spool Orientation

All sectional valves have right-hand spool extensions only. In a plan view of the valve with the pressure inlet located at 9 o'clock, the extension is located at 12 o'clock.

Spool Detents

Detents let the operator lock the spool in neutral or in one of the operating positions. Without detents, the spool will return to neutral when the operator removes his hand from the control lever.

Detents are available for all spools. The single detent position on a float spool is standard.

Detent Conversion Kit

This option provides the detent and attachment parts which may be added to valves in the field. When a detent is installed on a spool, the spool must be supported on the land closest to the end, otherwise the spool could be bent from the force of pressing in the detent.

Optional Centering Springs

Valves are available with half-load springs to provide spool centering under limited flow and pressure conditions.

Valves are available with light-load springs to provide a very light spool-centering force. The spring will not center the spool under any conditions, thus requiring manual return to neutral by the operator.

Hydraulic Actuators

CM2 and CM11 valves are available with hydraulic actuators which allow spools to be shifted by pilot pressure. Spool movement starts at 7 bar (100 psi), and the spool is fully shifted at 14 bar (200 psi). Maximum allowable pilot pressure is 24 bar (350 psi). The actuator may not provide required metering (inching) in critical applications.

Shifted spools spring center at rated valve flow and pressure when pilot pressure is released.

For hydraulic remote controls for pilot pressure actuation, see catalog GB-MC-2032.

Manual operation of the CM2 with hydraulic end caps is also possible. A force of 160 pounds is required to shift the spool from neutral.

Multiple Section Directional Valves

Electric Switch

CM2 and CM11 switch-actuated sections are available for use in circuits where the pump is driven by an electric motor. Their installation on electric lift trucks conserves the battery yet ensures the availability of peak power when required.

The switch, actuated by initial movement of the valve spool, starts the hydraulic pump which instantaneously supplies oil to the valve. The pump stops when the spool returns to its neutral position.

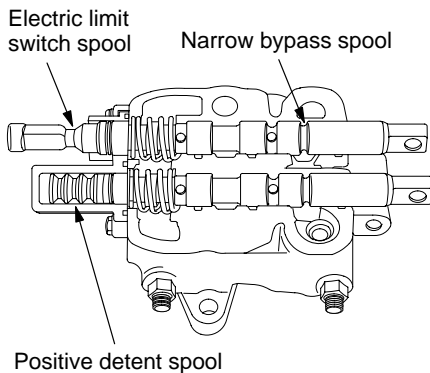

Electric Switch Conversion Kit

CM2 and CM11 units in the field may be converted to provide a bracket and cam for mounting and actuating electrical switches. The switch cam is press-fitted into the end of the valve spool. A 3M adhesive, No. EC847, must be applied to the extension to retain it in the spool.

Two-pressure System

This option is available with CM11 valves and is ideally suited for lift truck applications. It allows the use of lower pressure, lower cost components and hoses for "tilt" and accessory functions while providing higher pressure for the "lift" function. This system also generates less heat during relief valve operation for longer pump life or, considering battery powered lift trucks, saves current for longer operation between charges.

As illustrated in the following diagram, the two-pressure system is provided by adding a second pilot stage (2) to a CM11's hydrostat relief valve (1), and by using a special "W" spool. The setting of the second pilot stage controls the maximum pressure of all functions in the valve bank except the "W" spool (lift) function. The pressure setting of the pilot stage inside the hydrostat controls the maximum pressure of the "W" spool function.

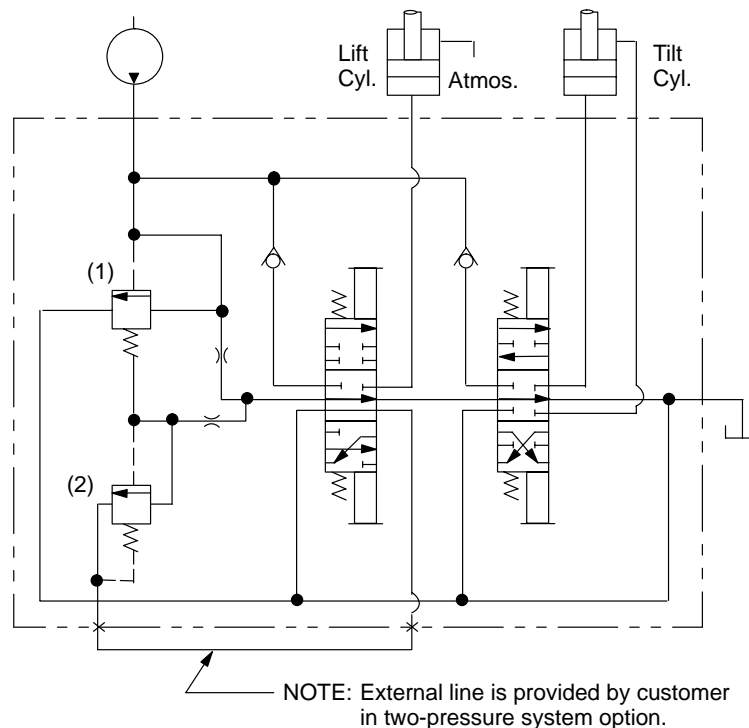

With the "W" spool in neutral, discharge flow from the second pilot stage is directed to tank through the normally plugged port of the single acting "W" spool. Shifting the "W" spool to raise a load blocks the discharge to tank of the second pilot stage; at this point the pilot in the hydrostat limits the pressure.

Lever Leakage Adapter

For CM11 valves, a modified handle adapter can be provided which incorporates a tapped hole for connection with any rod assembly required by the application. The adapter connects directly to the spool clevis.

This adapter is basically a CM11 valve handle in reference to all installation dimensions with the exception of the modified length and tapped hole.

Multiple Section Directional Valves

Lever Kits

Standard lever kits are available for all sectional valves and are shown on pages 20 and 21.

millimeters (inch)

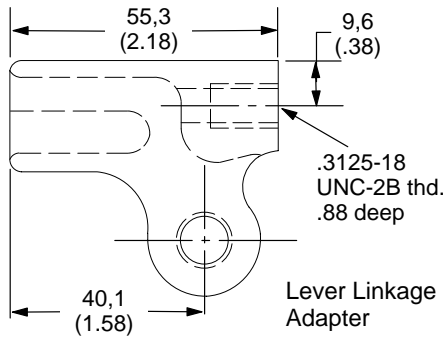

Mixture of Port Sizes

This option permits the use of different port sizes in the same valve bank. The use of reducer fittings to accommodate various size lines can thus be eliminated.

Dust Covers

Covers are standard on CM11 valve sections which do not incorporate detents or switch brackets. These covers prevent the entrance of contaminants into the end caps and can be installed in the field.

Viton Seals

This option allows valves to be used with synthetic fluids.

Specifications

Series	Nominal Capacity l/min (USgpm)	Rated Pressure bar (psi)	Approx. Dry Weight – Individual Sections			
			Inlet kg (lbs)	Intermediate kg (lbs)	Operating Outlet kg (lbs)	Outlet Plate kg (lbs)
CM11	113 (30)	210 (3000)	4,1 (9)	2,3 (5)	3,4 (7.5)	2 (4.5)
CM2	265 (70)		10,9 (24)	6,8 (15)	10,9 (24)	4,5 (10)

Typical Performance

Figures in performance data curves give approximate pressure drops (ΔP) when passing 100 SSU fluids having .865 specific gravity. Pressure drop for fluids of other viscosities is approximately:

Viscosity (SSU)	75	150	200	250	300	350	400
% of ΔP (Approx.)	93	111	119	126	132	137	141

For any other specific gravity, (G_1), pressure drop (ΔP_1) will be approximately: $\Delta P_1 = \Delta P \left(\frac{G_1}{G}\right)$

Multiple Section Directional Valves

Performance Data Curves

CM2 Series

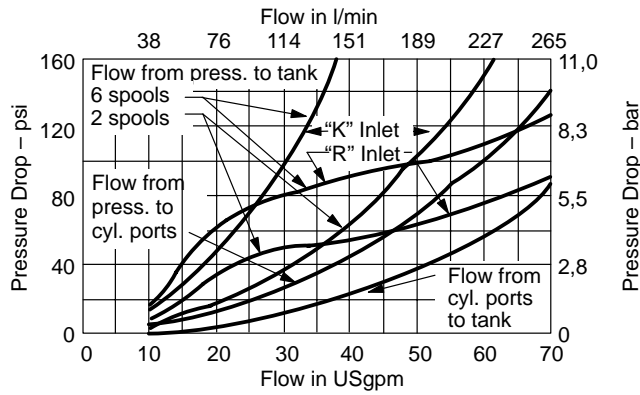

CM11 Series

Standard Spools B, C, D, T and W
 Spools in Neutral - Flow from Pressure to Tank

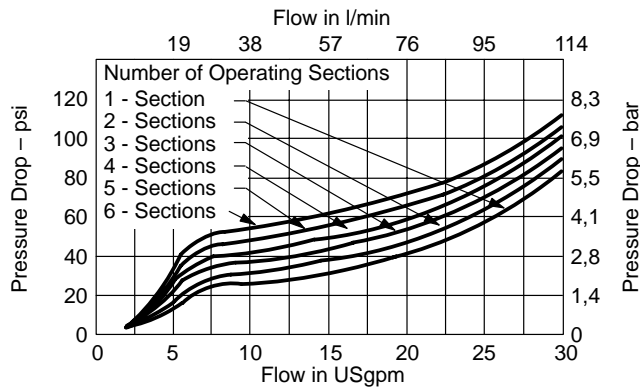

Flow from Cylinder Ports to Tank

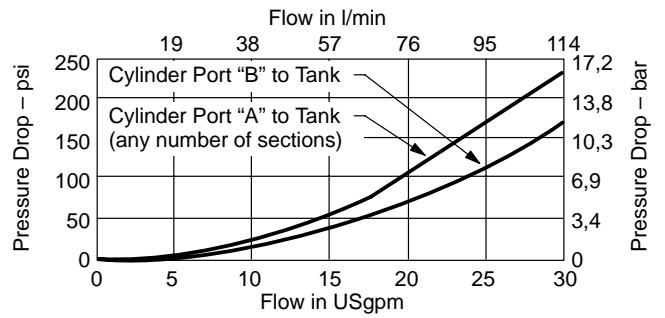

Low Flow Spools B, C, D, T and W
 Spools in Neutral - Flow from Pressure to Tank

Flow from Cylinder Ports to Tank

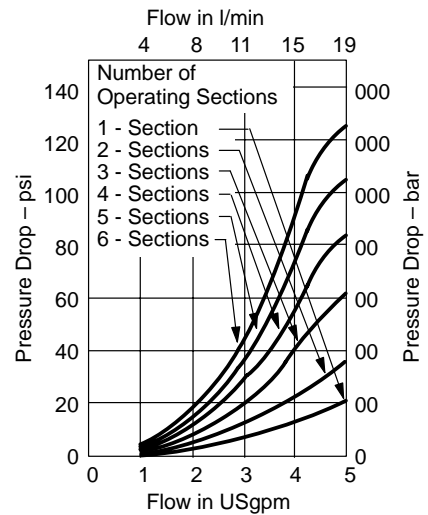
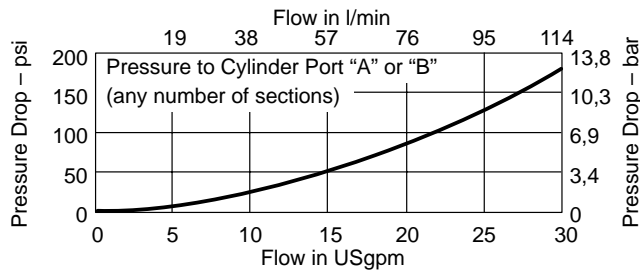

Installation Dimensions

CM2 Series

millimeters (inch)

Multiple Spool Valve

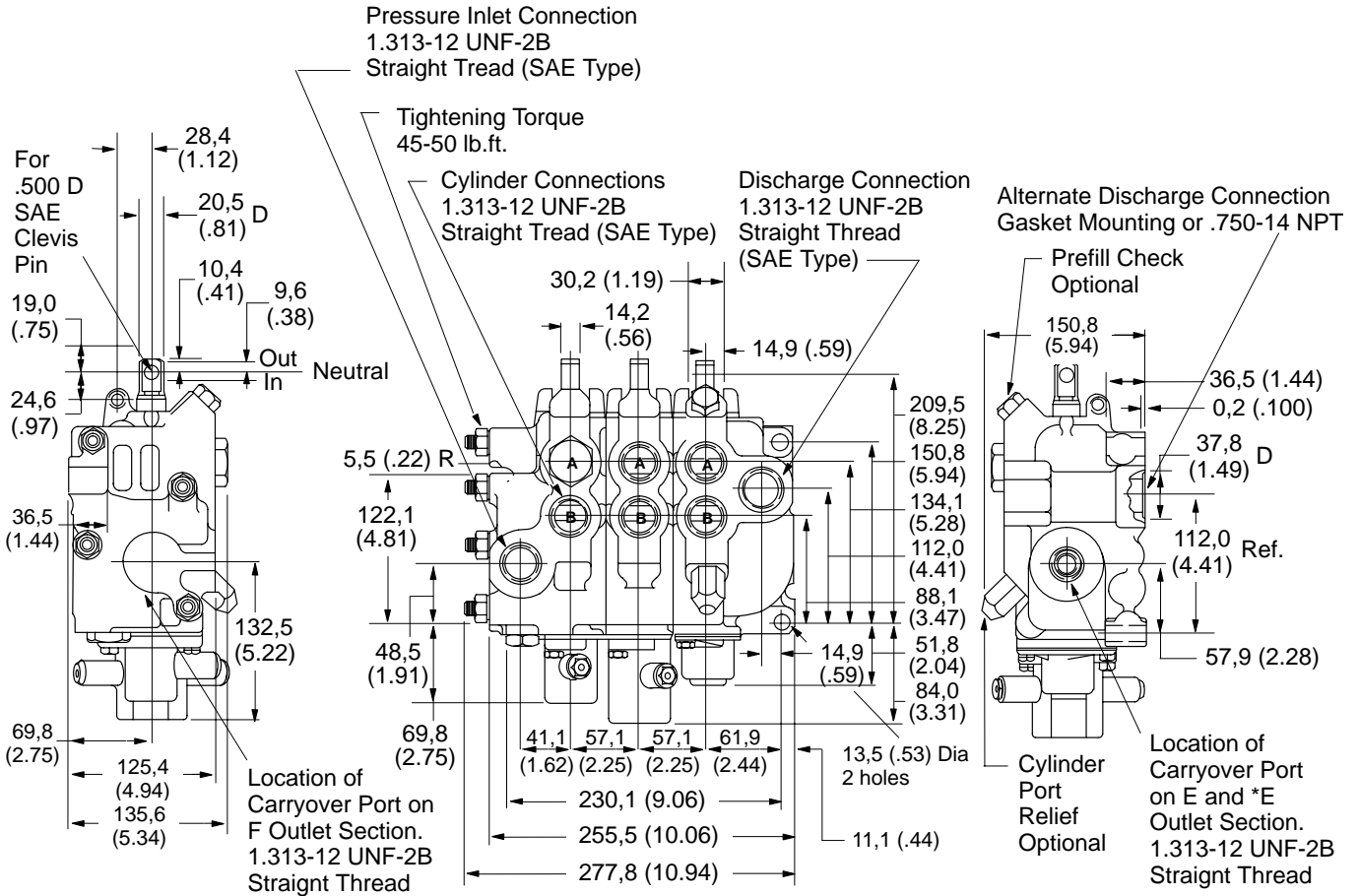

Single Spool Valve

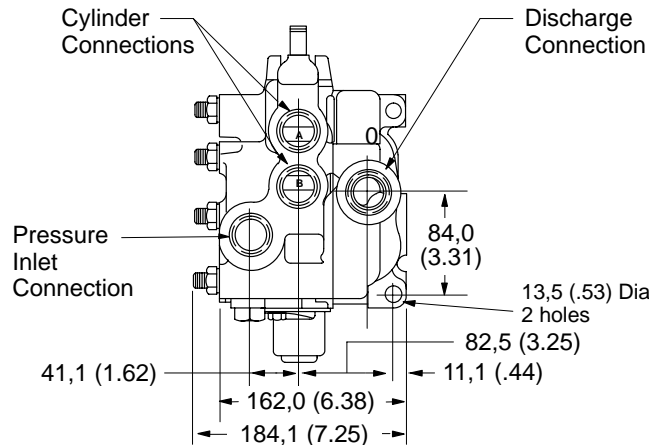

Installation Dimensions

CM2 Series with Hydraulic Actuators

millimeters (inch)

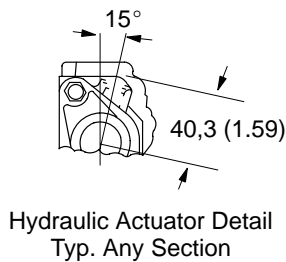
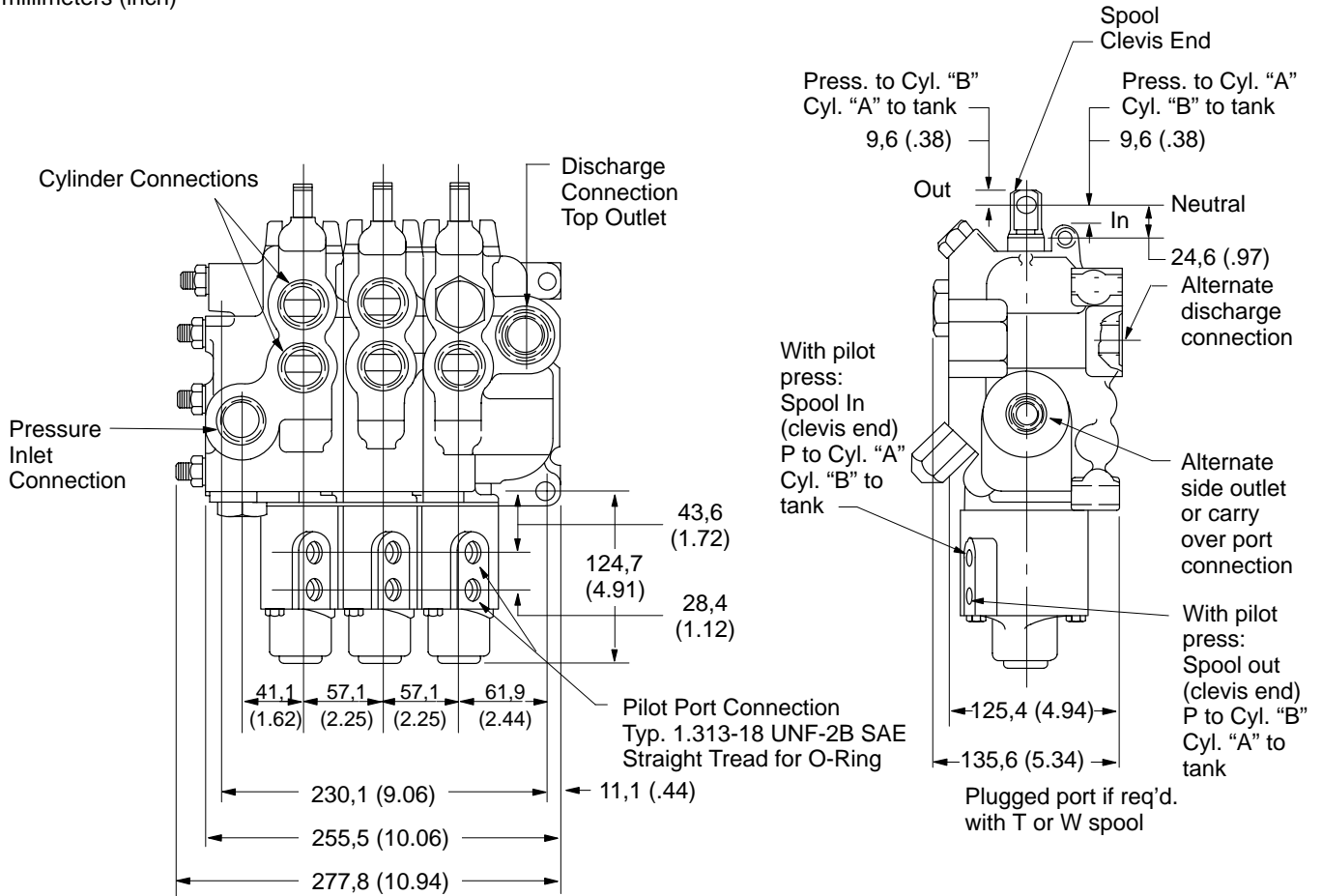

Operating pilot pressure – 14 bar (200 psi)
 Maximum pilot pressure on end cap – 24 bar (350 psi)
 (Spool fully shifted in or out)
 Minimum pilot pressure (to start spool shifting) – 7 bar (100 psi)
 Force to manually shift spool (in/out from neutral) at rated inlet flow and pressure on spool – 160 lbs.

For additional dimensions see previous page

Installation Dimensions

CM2 Series – Electric Switch Actuators

millimeters (inch)

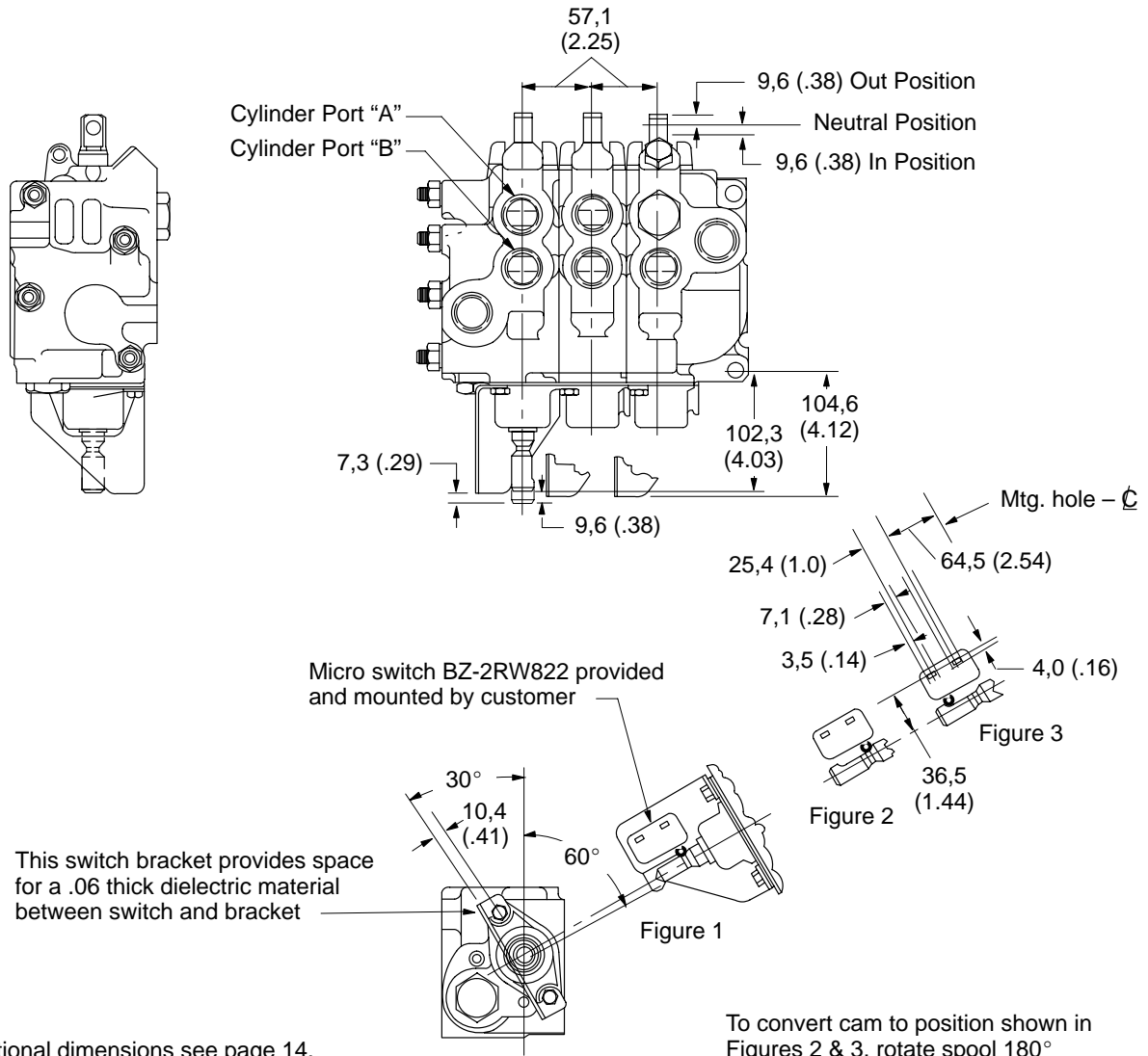

For additional dimensions see page 14.

Valve Section Type	Shifted Spool Position	Flow		Switch Mounting
		Cylinder Port A	Cylinder Port B	
Double Acting D	Out	Tank	Press.	Figure 1
	In	Press.	Tank	
Single Acting W	Out	Tank	Plugged	Figure 2
	In	Press.		
Single Acting T	Out	Plugged	Press.	Figure 3
	In		Tank	

Installation Dimensions

CM2 Series – Externally Adjustable System Relief Valve

millimeters (inch)

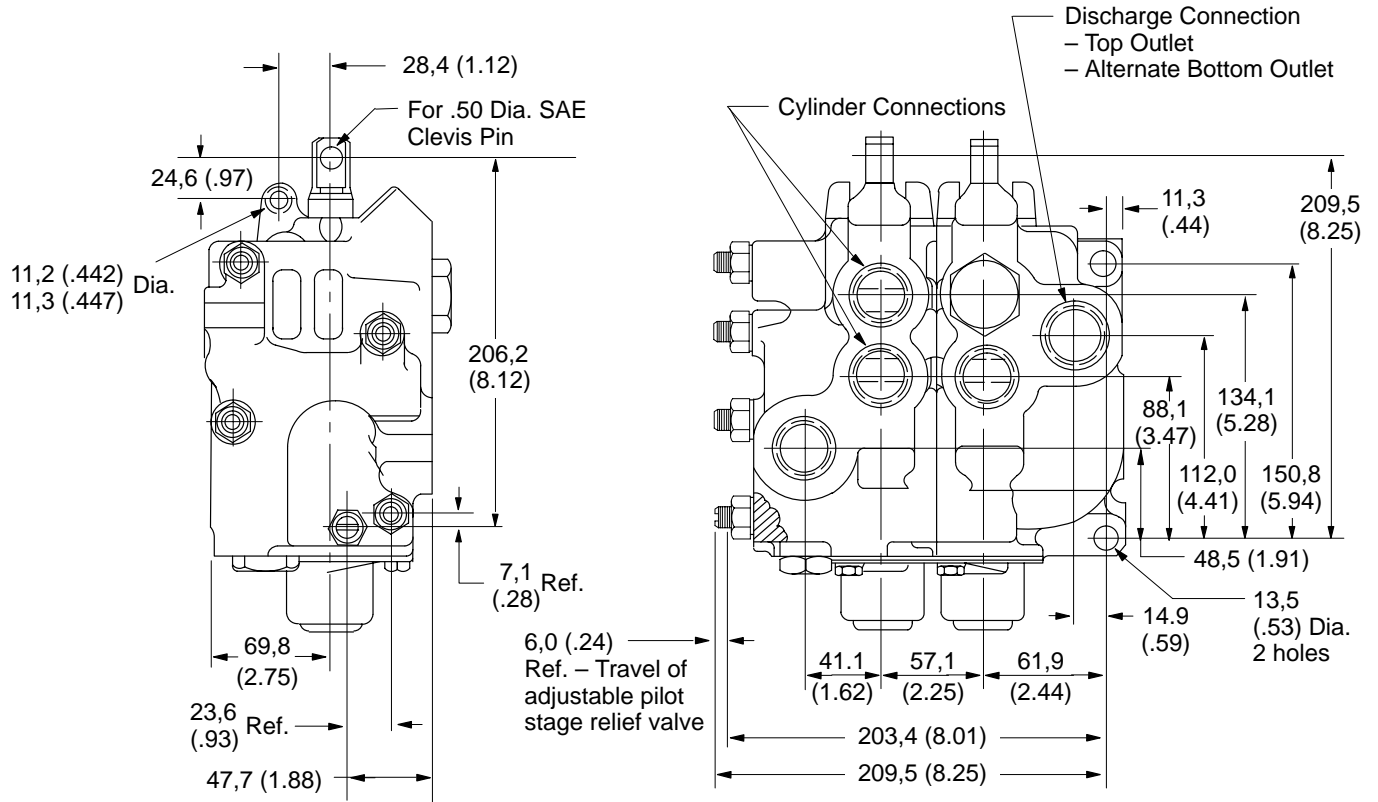

For additional dimensions see page 14.

Installation Dimensions

CM11 Series

millimeters (inch)

Single Spool Valve

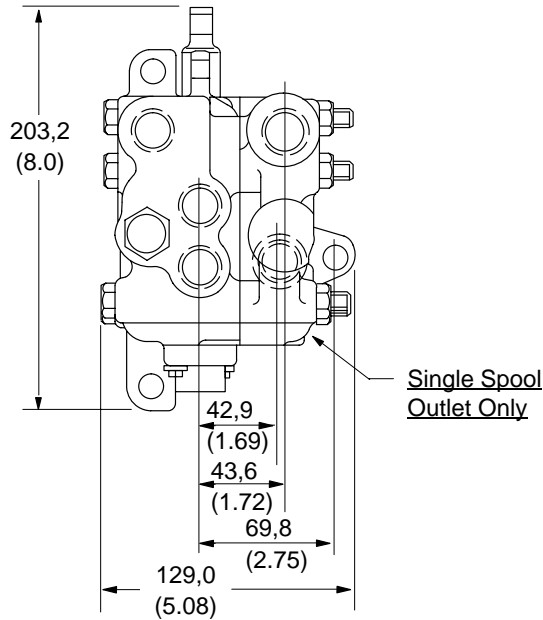

Multiple Spool Valve

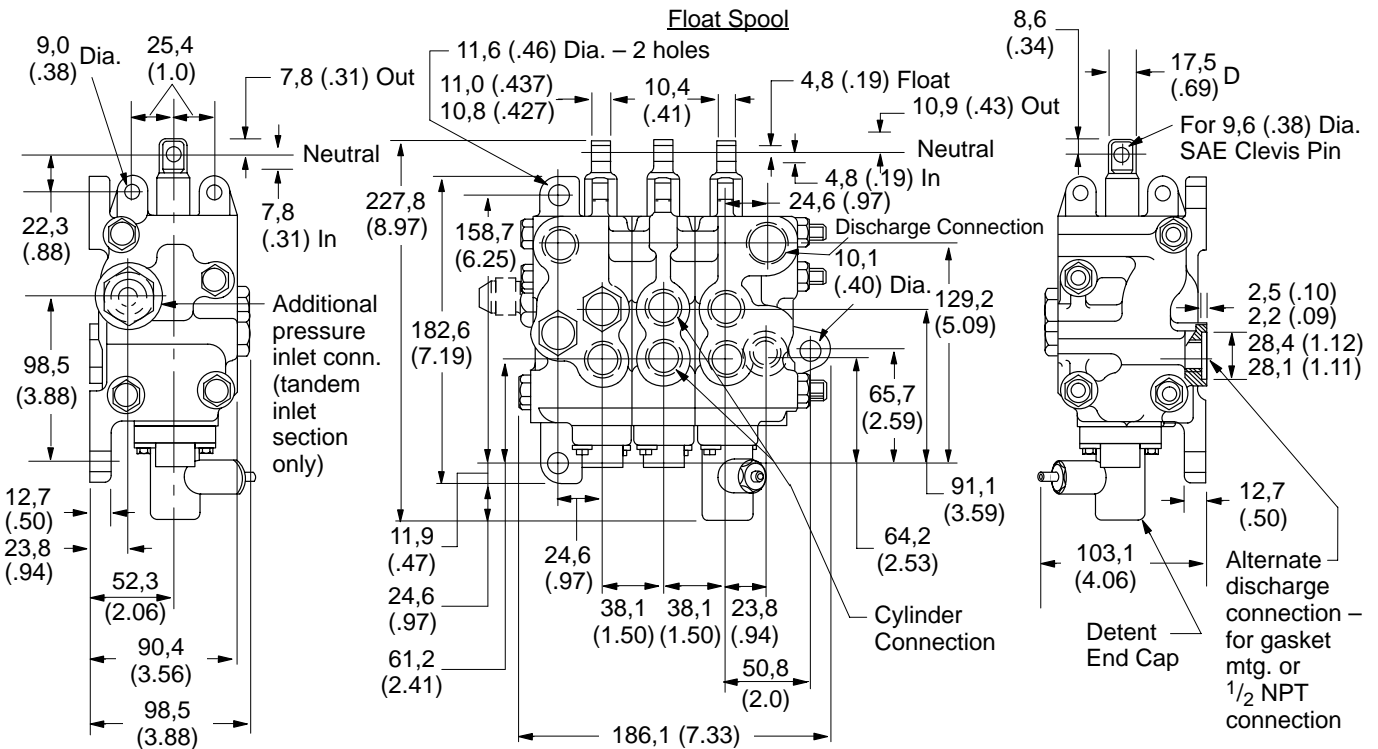

Port Connections (for SAE Straight Thread Fittings and "O" Ring Seals)

Model Code Symbol	Pressure Inlet Connections	Cylinder Connections	Discharge Connections
1	7/8-14 UNF-2B	3/4-16 UNF-2B	7/8-14 UNF-2B
2	1-1/16-12 UNF-2B	7/8-14 UNF-2B	1-1/16-12 UNF-2B

Installation Dimensions

CM11 Series – Electric Switch Actuators

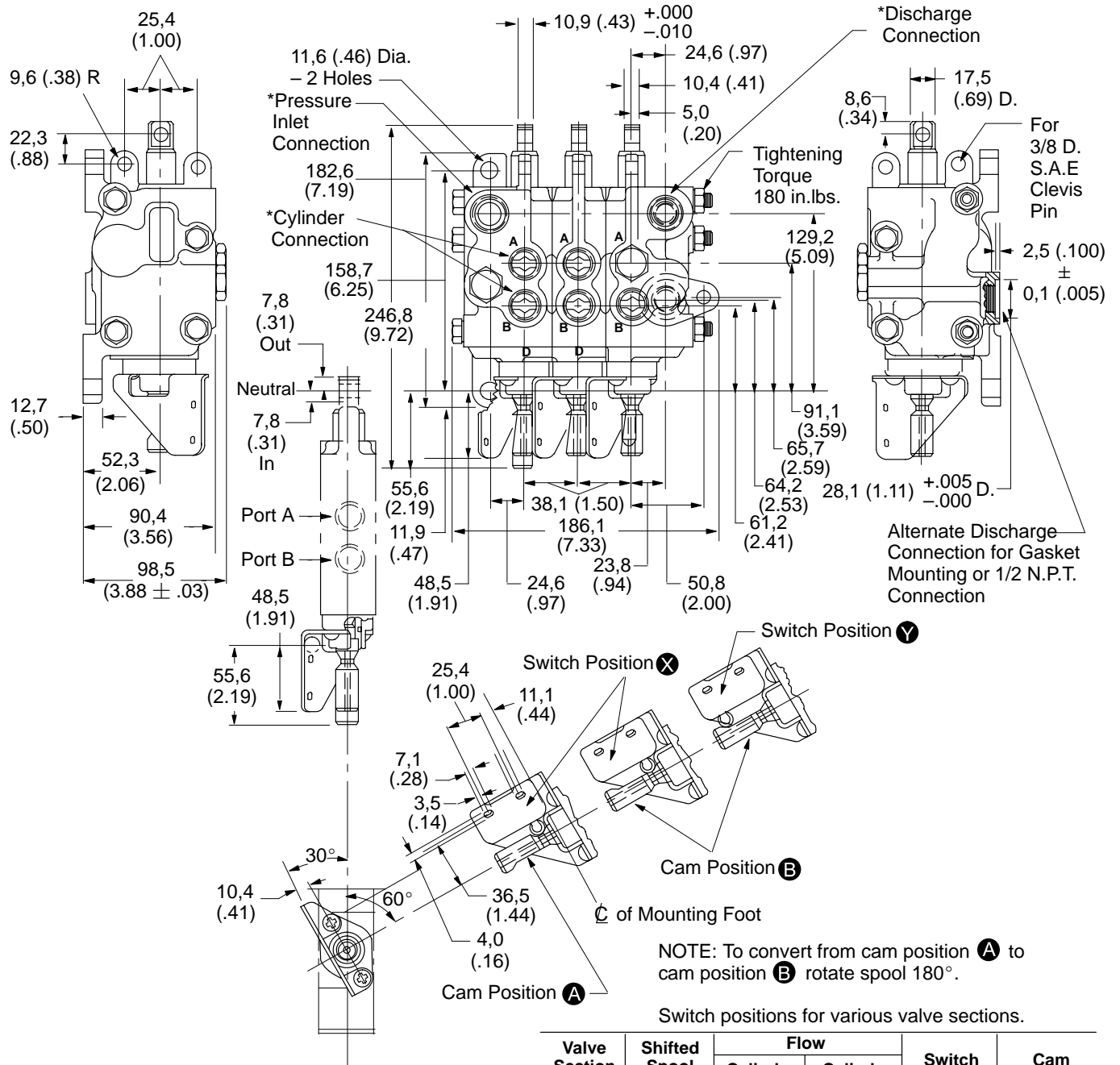

*Refer to chart on preceding page for optional port connections.

NOTE: Switch brackets and actuators are provided by Vickers. Customer must provide and mount microswitch model BZ-2RW822-** or equivalent. Space is provided for 0.06 inch di-electric material between switch and bracket.

NOTE: To convert from cam position **A** to cam position **B** rotate spool 180°.

Switch positions for various valve sections.

Valve Section Type	Shifted Spool Position	Flow		Switch Position	Cam Position
		Cylinder Port A	Cylinder Port N		
Double Acting "B" & "D"	In	Tank	Pressure	X	A
	Out	Pressure	Tank		
Single Acting "T"	In	Plugged	Pressure	X	B
	Out		Tank		
Single Acting "W"	In	Tank	Plugged	Y	B
	Out	Pressure			

Installation Dimensions

CM11 Series – Externally Adjustable System Relief Valves

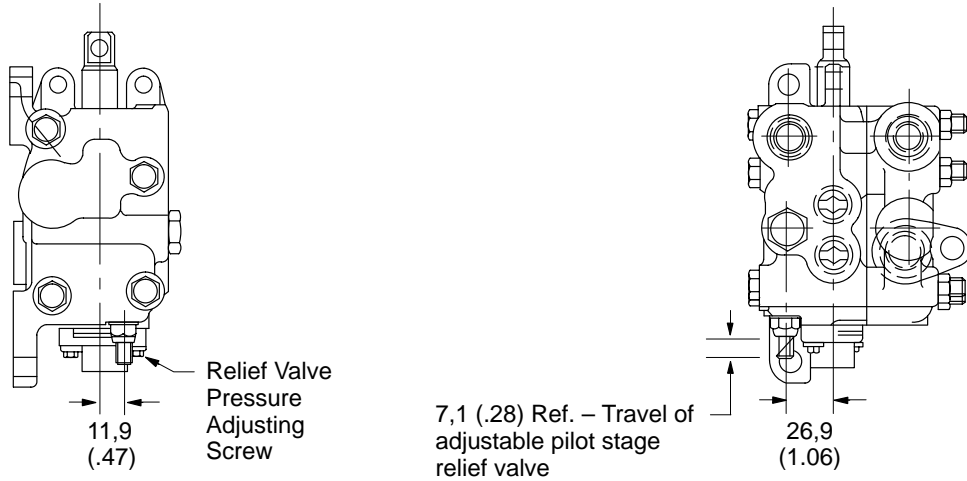

For additional dimensions, refer to page 18.

CM2 Series Control Lever

Hand operating lever assemblies are available for directional valve sections in groups of one to ten levers.

Lever groups include necessary fulcrum rod, links and "E" washers for assembly.

Specify number of levers required in addition to valve assembly or section selected as in the following example:

- One (1) CM2NO2-R25DDDL-30 Valve Assembly
- One (1) CM2H3-30 Hand Lever Assembly

NOTE: Number after the H denotes number of operating sections.

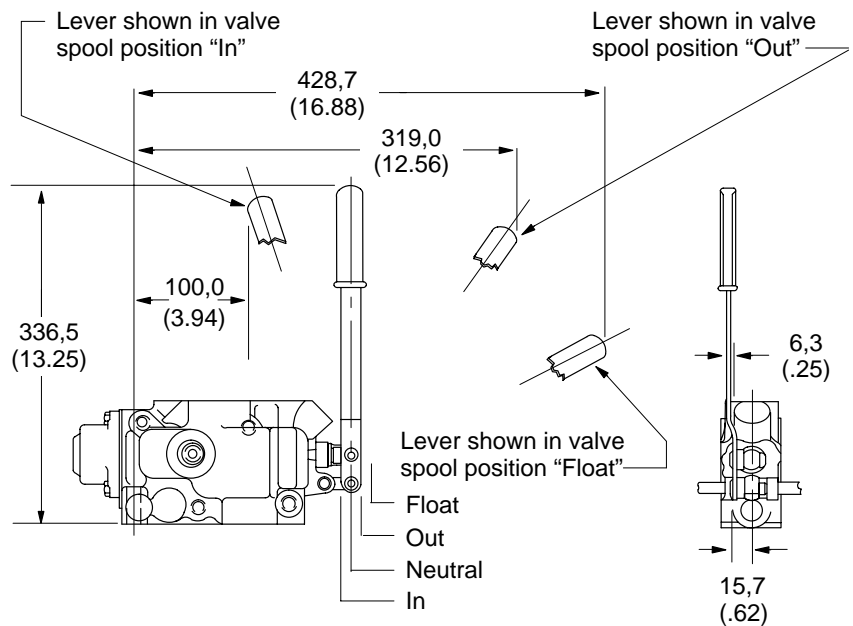

Installation Dimensions

CM11 Series Control Lever

Levers may be assembled with fulcrum in the lower holes to extend levers in the opposite direction.

Hand operating lever assemblies are available for directional valve sections in groups of one to ten levers.

These lever groups include the necessary fulcrum rod, "E" washers, and clevis pins for assembly

Specify in addition to valve assembly or section selected and indicate the number of levers required as in the following example:

- One (1) CM11NO1-R**DBTTWCL-21 Valve Assembly
- One (1) CM11H6-20 Hand Lever Assembly

NOTE: Number after the H denotes number of operating sections.

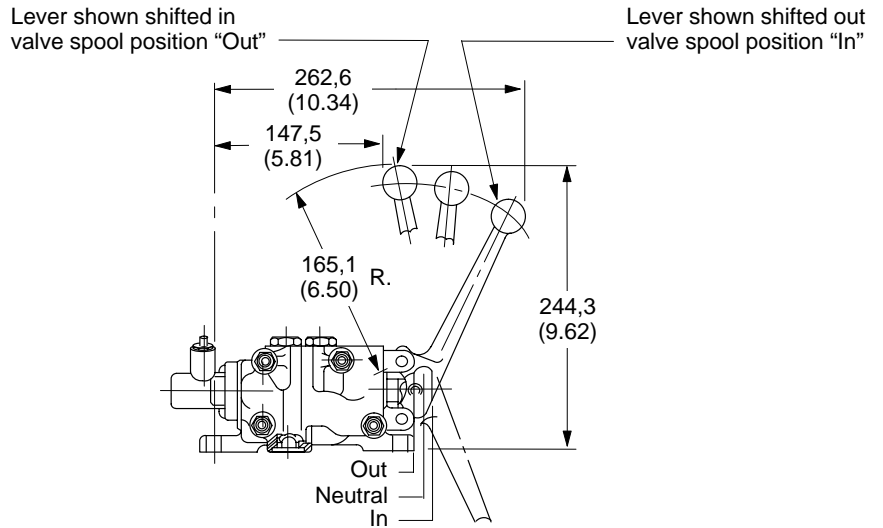

Model Codes

CM2 Series

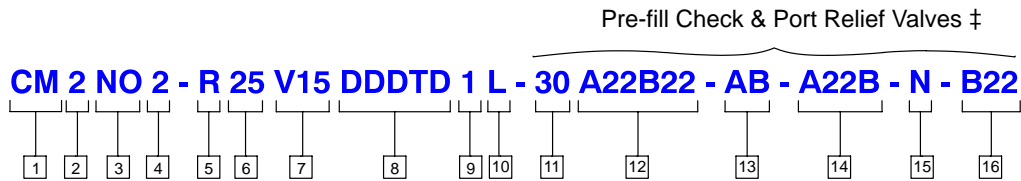

1 Multiple Unit Control Valve – Mobile

2 Series Designation

3 Valve Bank Modification

NO = No modification
NS = Standard Sections – Electric Switch Actuators

4 Port Connections

2 = 1-5/16-12 UNF-2B Inlet and Cylinders

5 Inlet Body Type

F = Carryover Port – No Relief Valve
R = Standard – Relief Valve (partial flow bypass)
K = Standard – Relief Valve (full flow bypass)

6 System Relief Valve Setting – PSI

00 = No relief, K section only
05 = 500 12 = 1250 20 = 2000 27 = 2750
07 = 750 15 = 1500 22 = 2250 30 = 3000
10 = 1000 17 = 1750 25 = 2500

7 Adjustable System Relief Valve Settings – PSI (Omit if not required.) Set at least 250 PSI lower than main relief valve

V05 = 500 V15 = 1500 V25 = 2500
V07 = 750 V17 = 1750 V27 = 2750
V10 = 1000 V20 = 2000 V30 = 3000
V12 = 1250 V22 = 2250

8 Spool Type

B = Motor D = Double Acting
C = Float T = Single Acting
W = Reverse T Spool (Single Acting)

9 Spool Modification (Omit if not required.)

1 = Detent for B, D, T or W Spools
8 = Hydraulic Actuator

10 Outlet Body Type †

L = Standard
E = Carryover Port

11 Design Number

Design numbers subject to change. Installation dimensions remain the same for designs 30 thru 39.

12 1st Spool

A** = Check & Port Relief on End A
B** = Check & Port Relief on End B

Port Relief Settings – PSI

07 = 750 17 = 1750 27 = 2750
10 = 1000 20 = 2000 30 = 3000
12 = 1250 22 = 2250 32 = 3250
15 = 1500 25 = 2500 35 = 3500

13 2nd Spool

A = Check only on End A
B = Check only on End B

14 3rd Spool

A22 = Check & Port Relief Set at 2250 PSI on End A
B = Check only on End B

15 4th Spool

N = No Check or Relief in Port A or B

16 5th Spool

B22 = Check & Port Relief Set at 2250 PSI in B Port only. Nothing in Port A.

† Outlet body contains a spool in multi-spool banks. Outlet body contains no spool in a single spool valve; spool is in inlet body.

‡ All spools available with any combination of checks and port reliefs.

Consult your Vickers representative regarding the ordering of options not listed in this code.

Model Codes

CM11 Series

CM 11 NO 2 - R 25 V15 DDDTD 1 L - 21

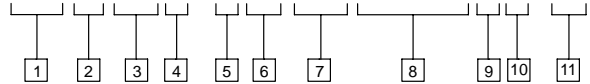

1 Multiple Unit Control Valve – Mobile

2 Series Designation

3 Valve Bank Modification

- NO = No modification
- NS = Standard Sections – Electric Switch Actuators
- ND = Standard Sections – Dust Covers
- ZO = Narrow Bypass Sections – No Modifications
- ZS = Narrow Bypass Sections – Electric Switch Actuators
- ZD = Narrow Bypass Sections – Dust Covers

4 Port Connections

- 1 = 7/8-14 UNF-2B Inlet & Discharge; 3/4-16 UNF-2B Cylinders
- 2 = 1-1/16-12 UNF-2B Inlet & Discharge; 7/8-14 UNV-2B Cylinders

5 Inlet Body Type

- F = Carryover Port – No Relief Valve
- R = Standard – Relief Valve (7 USgpm bypass)
- K = Standard – Relief Valve (15 USgpm max. bypass)
- J = Standard – Relief Valve (9 USgpm bypass)

6 System Relief Valve Setting – PSI

- 00 = No relief, K section only
- 05 = 500 12 = 1250 20 = 2000 27 = 2750
- 07 = 750 15 = 1500 22 = 2250 30 = 3000
- 10 = 1000 17 = 1750 25 = 2500

7 Adjustable System Relief Valve Settings – PSI (Omit if not required.) Set at least 250 PSI lower than main relief valve

- V05 = 500 V15 = 1500 V25 = 2500
- V07 = 750 V17 = 1750 V27 = 2750
- V10 = 1000 V20 = 2000 V30 = 3000
- V12 = 1250 V22 = 2250

8 Spool Type

- B = Motor D = Double Acting
- C = Float T = Single Acting
- W3 = Safety Interlock
- A6 = Counterbalance
- W = Reverse T Spool (Single Acting)

9 Spool Modification (Omit if not required.)

- 1 = Detent for any spool
- 2 = Light Centering Spring
- 7 = Half-load Centering Spring

10 Outlet Body Type *

- L = Standard
- E = Carryover Port
- E1 = E Section with Additional Outlet Port

11 Design Number

Design numbers subject to change. Installation dimensions remain the same for designs 30 thru 39.

* Outlet body contains a spool in multi-spool banks. Outlet body contains no spool in a single spool valve; spool is in inlet body.

Consult your Vickers representative regarding the ordering of options not listed in this code.

Pressure and Flow Control Valves

RM3 Overload Relief Valve

The RM3 is an internally pilot operated valve which provides pressure protection to the hydraulic system. Pressure settings are preset at the factory and are available from 35-175 bar (500-2500 psi) in increments of 17 bar (250 psi). Tank line pressures are additive to relief valve settings.

Maximum operating pressure is 175 bar (2500 psi). Approximate weight is 1,1 kg (2.5 lb.).

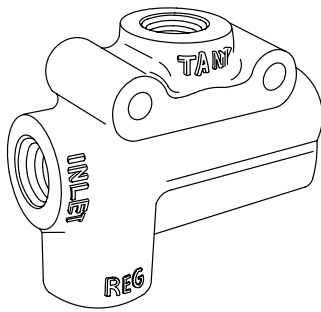

FM3 Flow Control and Relief Valve

The FM3 is a bypass type pressure compensated flow control and a relief valve. It is used in applications where a constant actuator speed is required in the face of varying pump output . . . for example, in power steering.

All inlet oil in excess of the specified regulated flow is diverted to the tank port. Pressure protection is provided by an integral relief valve which is preset at the factory. Available controlled flow rates and relief valve settings are shown in the model code on page 26. Tank line pressures are additive to relief valve settings.

Maximum operating pressure is 175 bar (2500 psi). Pressure drop between the inlet and regulated flow port is about 2.8 bar (40 psi). Approximate weight is 1,1 kg (2.5 lb.).

Typical Performance Based on 60 SUS Viscosity Oil

RM3 & FM3 Series

Relief Valve Pressure Override Characteristics

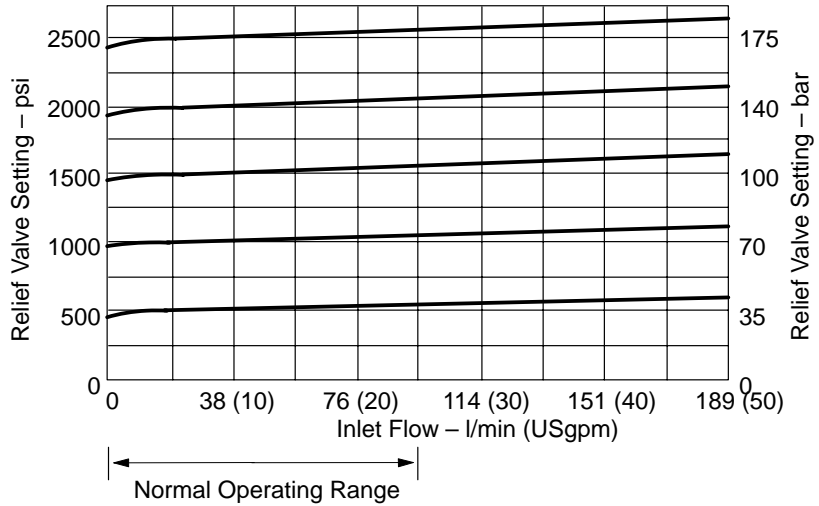

FM3 Series

Flow Control Characteristics

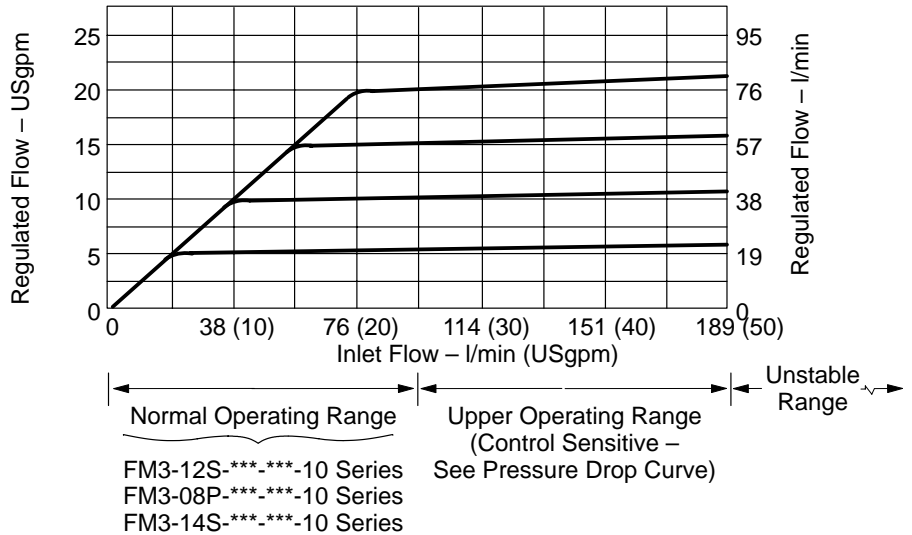

FM3 Series

Pressure Drop – Inlet to Tank

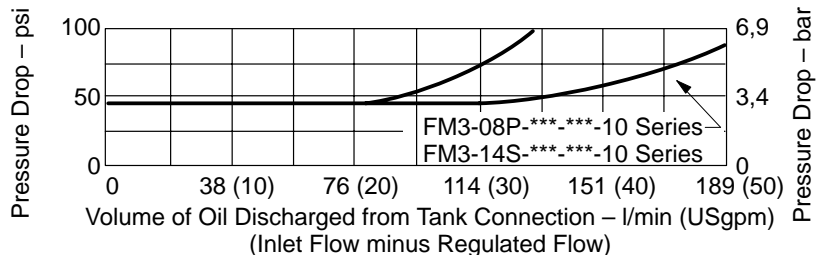

Installation Dimensions

RM3 Series

millimeters (inch)

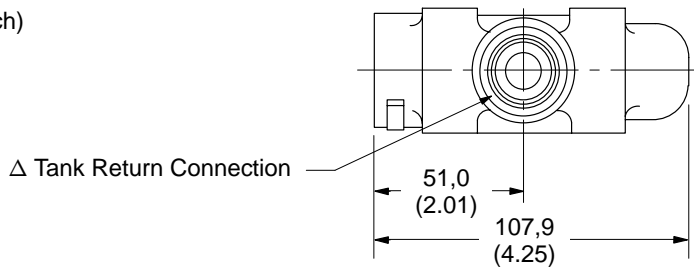

Δ Port Connections	
Code Symbol	Thread Size
08P	1/2 N.P.T.
12S	3/4-16 U.N.F.-2B Str. Thread
14S	7/8-14 U.N.F.-2B Str. Thread

Straight thread connections are for SAE straight thread fittings and "O" ring seals.

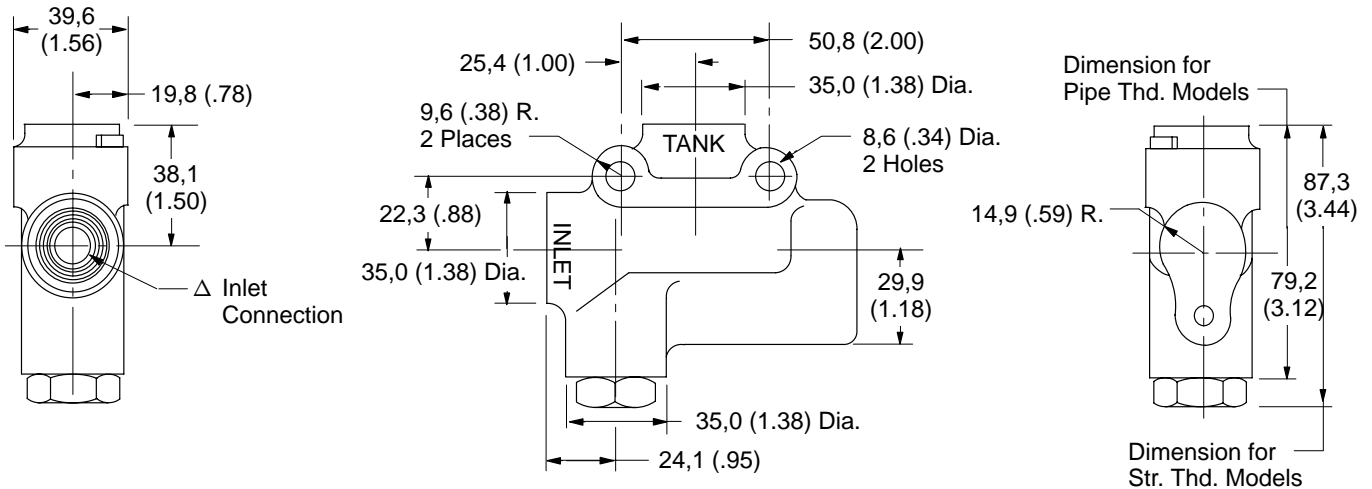

FM3 Series

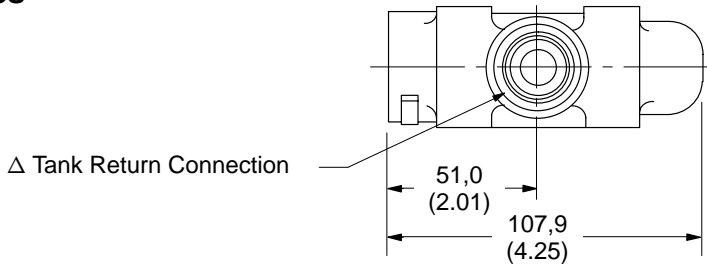

Δ Port Connections	
Code Symbol	Thread Size
08P	1/2 N.P.T.
12S	3/4-16 U.N.F.-2B Str. Thread
14S	7/8-14 U.N.F.-2B Str. Thread

Straight thread connections are for SAE straight thread fittings and "O" ring seals.

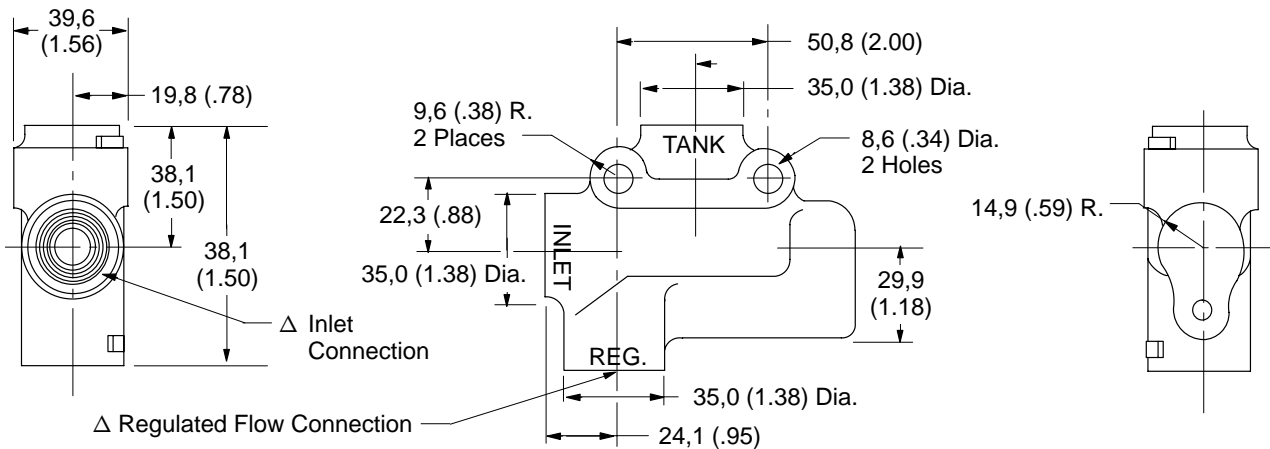

Model Code

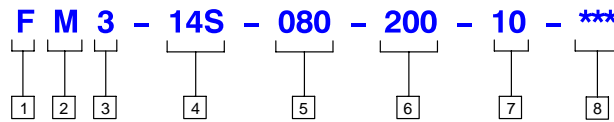

1 Valve Type

F = Flow Control & Relief
R = Relief

2 Mobile Design

3 Series Designation

4 Port Connections

08P = 1/2 NPT Thread
12S = 3/4 SAE Str. Thread
14S = 7/8 SAE Str. Thread

5 Controlled Flow Rates (FM3 series only)

020 = 2 gpm	130 = 13 gpm
040 = 4 gpm	160 = 16 gpm
060 = 6 gpm	200 = 20 gpm
080 = 8 gpm	250 = 25 gpm
100 = 10 gpm	

6 Relief Valve Setting

050 = 500 psi	175 = 1750 psi
075 = 750 psi	200 = 2000 psi
100 = 1000 psi	225 = 2250 psi
125 = 1250 psi	250 = 2500 psi
150 = 1500 psi	

7 Design Number

Subject to change. Installation dimensions remain the same for designs 10 thru 19.

8 Special Features Suffix

Application Guidelines

Pressure Drop

Select the valve that has minimum pressure drop at the required flow condition. Performance curves on preceding pages show approximate pressure drops (ΔP) through valves using 100 SUS fluids having .865 specific gravity. Pressure drop for fluids of other viscosities is approximately:

Viscosity (SSU)	75	150	200	250	300	350	400
% of Δ from Curve (Approx.)	93	111	119	126	132	137	141

For any other specific gravity, (G_1), pressure drop (ΔP_1) will be

$$\Delta P_1 = \Delta P \left(\frac{G_1}{G} \right)$$

For pressure drop data beyond the published curves in this catalog, a close proximation can be made by reading the pressure drop at 1/2 the required flow and multiplying it by 4.

When installing a valve, connecting lines should have as few bends and fittings as possible. High pressure lines and fittings restrict flow and may result in excessive pressure drop through the

system. They should be used only where necessary in a pressure line.

Select quality tubing with as large an ID as economically possible. Avoid long lines and sharp bends. A good bend radius is $2\frac{1}{2}$ to 3 times the tube ID.

The increased pressure drop in sharper bends is caused by abrupt changes in flow direction, particularly in the inner edge of flow. Even in large-radius bends, pressure drop increases due to an increase in turbulence.

Circuit design to eliminate undesirable pressure drop can never be 100 percent effective. Some energy losses through heat generation must be accepted. Therefore, wherever possible, valves should be placed in the open where heat can be dissipated readily. If heat is added to the system

faster than it can be rejected, some method of forced fluid cooling such as air- or water-cooled heat exchangers may be required.

Piping

Lines should be installed in such a way that high vehicle flexure does not cause stresses in the tubing which can be transmitted to valve port fittings.

When applications incorporate long hydraulic lines, or lines providing high velocity, the use of larger capacity lines is recommended to reduce line losses. Lines should not be smaller than the nominal port sizes shown in installation drawings. Flow capacities of piping are shown in catalog 694.

Connections should always be tight, but not to the point of distortion, to prevent air from entering the system. Particular care must be used to employ joints, seals and gaskets that will not leak or deteriorate. See preceding "Pressure Drop" section for additional information on piping.

Application Guidelines

Hose

When installing a hose, allow enough slack to avoid kinking. A taut hose will not allow movement with pressure surges. Slack in the line compensates for surges, relieving strain. The hose should not be twisted during installation or while in operation. Twisting will weaken the hose and loosen connections.

A neater installation is usually obtainable by using extra fittings to minimize unusually long loops in a hose. Hoses should be secured and protected against rubbing, chafing, and entanglement with moving parts.

Relief Valves

Relief valve settings specified in model codes are nominal “cracking pressures.” Any increase in relief valve pressure due to flow is called the “full flow pressure.” System tank pressures are also additive to the relief valve settings.

It is preferable to keep a 17 bar (250 psi) differential between the system relief valve setting and the port relief valve setting to prevent interaction between the two valves. Port relief valves with pressure settings lower than the system relief valve setting can be used to protect functions incorporating components with low pressure ratings.

It is desirable to have the system designed so that relief valves are inoperative during the normal work cycle. Such a system eliminates one of the causes of heat generation and oil aeration.

On functions incorporating a hydraulic motor and a blocked cylinder port spool, it is preferable to provide a crossport relief valve as close as possible to the motor to prevent motor failure.

Shifting Forces

Standard centering springs provide spool centering at maximum rated flow and maximum rated pressure. Each valve is tested to ensure centering prior to shipping. On applications where valves are being used below rated conditions, or where maximum rated flow and maximum rated pressure are not achieved simultaneously, lower spring loads which provide lower shifting forces can be provided.

Internal Leakage

The spool and body of each directional valve are select fitted to provide low leakage. It is not practical to replace spools on units in the field. On applications where no cylinder drift is allowable when supporting a load, pilot check valves or similar means should be provided.

When using directional valves in closed-center constant pressure type systems, consideration should be given to cylinder creep due to leakage from the pressure area of the valve into the cylinder ports.

Flow

On functions encountering overrunning loads, protection should be provided to prevent cavitation. Cavitation can draw air and contaminants into the circuit, reducing component life. On functions incorporating cylinders with differential areas, consideration should be given to the high return flows experienced when retracting cylinders.

Mounting

Valves can be mounted in any position. They should be securely bolted to a flat surface or resilient mounting pad to prevent distortion of the valve body.

Valves should be mounted in a protected area, free from falling debris, to protect linkage and spool extensions. Enough clearance must be left to provide access to port connections, and to permit actuation of the control mechanism.

Operating Linkage

Linkage for actuation of the valve spool must be properly aligned. Binding linkage will restrict the spool from returning to the neutral position when the control mechanism is released.

Operating linkage should rely on maximum travel stops provided in the valve to assure full spool travel and avoid adjustment problems.

Filtration

To insure reliable system performance, adequate fluid filtration and protection from environmental contaminant ingress should be provided. The system should not have a contamination level greater than 18/13 as measured in accordance with the ISO cleanliness code (Proposed ISO Solid Contaminant Code).

A 10-micron filter in Vickers' OFR or OFS series, sized to accommodate full return line flow, is recommended for most operating environments. If the system operates in a severely contaminated atmosphere, it is recommended that the 3 micron element be used because of its higher contaminant removal rate. The air breather should also be of a similar high contaminant removal rate. The filter element contaminant holding capacity and change interval are important selection criteria.

Filters should have nominal pressure, bypass check valves (see the following figure) to protect the system during cold starts and whenever the filter element becomes clogged. Bypass filters should be able to filter the equivalent of all system fluid within eight hours.

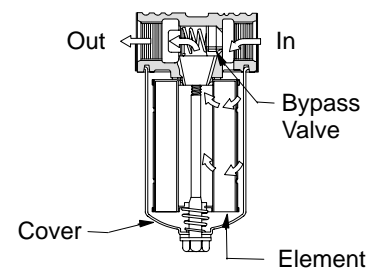

Application Guidelines

When possible, filters should be located in the tank return line where they trap contaminants before the oil re-enters the reservoir (see the following figure). This location also permits using a low-pressure type filter. Since return line filter elements must be changed at regular intervals, the filter should be located in an accessible area. For this reason, it is best not to locate the filter inside the reservoir.

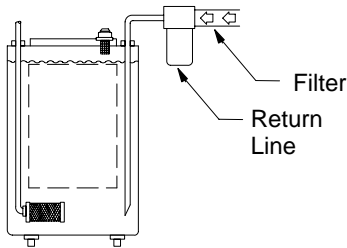

Reservoir

Reservoir and circuit design must prevent aeration of the fluid. Any opaqueness or milky appearance of the fluid in the lines or reservoir indicates excessive aeration. Bubbles on the surface of reservoir fluid may also indicate excessive aeration. It is best to use windows and sight glasses in reservoirs and inlet lines during vehicle prototype evaluation to determine whether significant amounts of air are present in the fluid.

Return lines discharging into the reservoir should discharge below the low limit oil level, as far from the pump inlet as possible (see figure below). This will prevent aeration and cavitation when oil is being drawn from the reservoir to fill voids in the valve. Tank return lines should be attached to the reservoir by flanges or welded heavy-duty coupling.

A baffle plate in the reservoir is desirable to separate the suction and return lines. The plate causes return oil to circulate around the outer wall for cooling before it re-enters the pump. It also helps provide time for entrained air to separate from the oil. Baffle plate openings should be designed to minimize cascade effects and resultant air entrainment.

Magnets can be used in a reservoir to pick up ferrous particles not retained by filters or strainers. Magnets should be assembled to the support bars located between suction and return lines, and be accessible for cleaning.

Miscellaneous

For optimum seal life, tank pressure at the directional valve should be held to a minimum.

Systems should be designed to operate at a maximum temperature of 49°C (120°F).

Under certain conditions, the valves described in this booklet may be operated at flows and pressures higher than published. If standard valves do not meet your system requirements, customized units can be made available. Please contact your local Vickers representative regarding special application requirements.

