

S

**Eaton®**  
Hydrostatic Transaxles

11-04-888  
EN-0101  
(Replaces 11-888)



h  
y  
d  
r  
a  
u  
n  
i  
c  
s

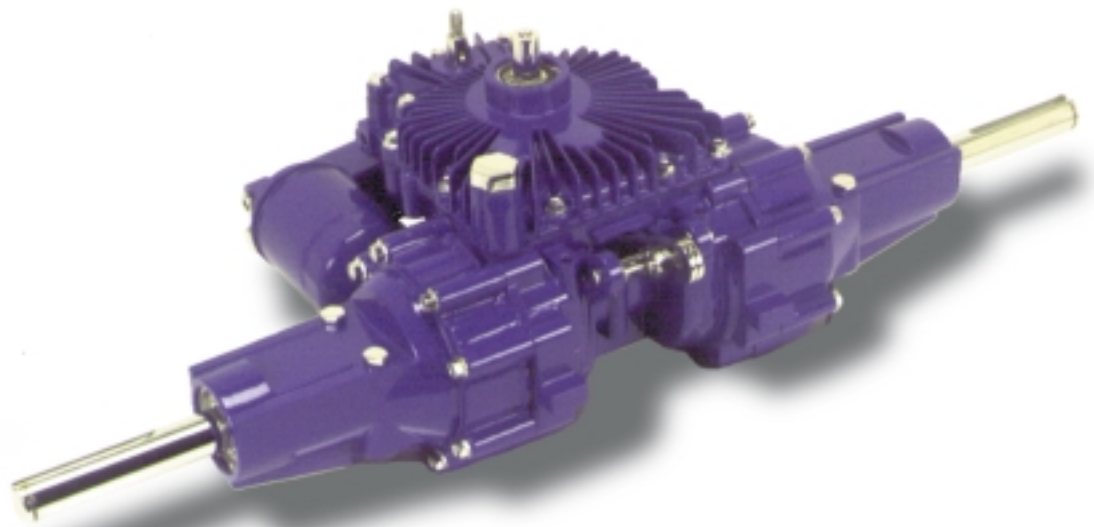

**Models 751, 851, 771, and 781  
Hydrostatic Transaxles**

We Manufacture

**Solutions**

Hydraulics

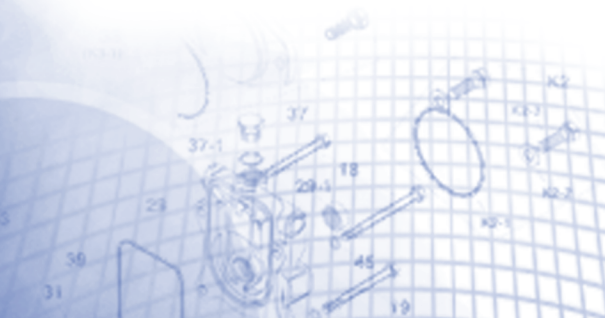

# Models 751, 851, 771, and 781

## Eaton Hydrostatic Transaxles

Eaton Models 751, 771, 781, and 851 use the time proven ball piston design for both pumps and motors. The Models 751 and 851 use one ball piston pump and two ball piston motors to provide the speed and torque required to propel vehicles of many different sizes.

### Transaxles for the ZTR (Zero Turn Radius) type vehicles

The 771 is an assembly with one pump and one motor. Two assemblies, a right and left, are required on each vehicle. The 781 consists of two units similar to the 771 joined together to make one assembly.

## Eaton Ball Piston Design

The simple ball piston design provides high efficiency, and long life. It is environment and temperature tolerant. This means that the transaxle is resistant to damage.

## Eaton Transaxles

Eaton hydrostatic transaxles have integral pump(s), motor(s) and axle housing with planetary gears using state-of-the-art materials, to provide a strong , long lasting, compact drive package.

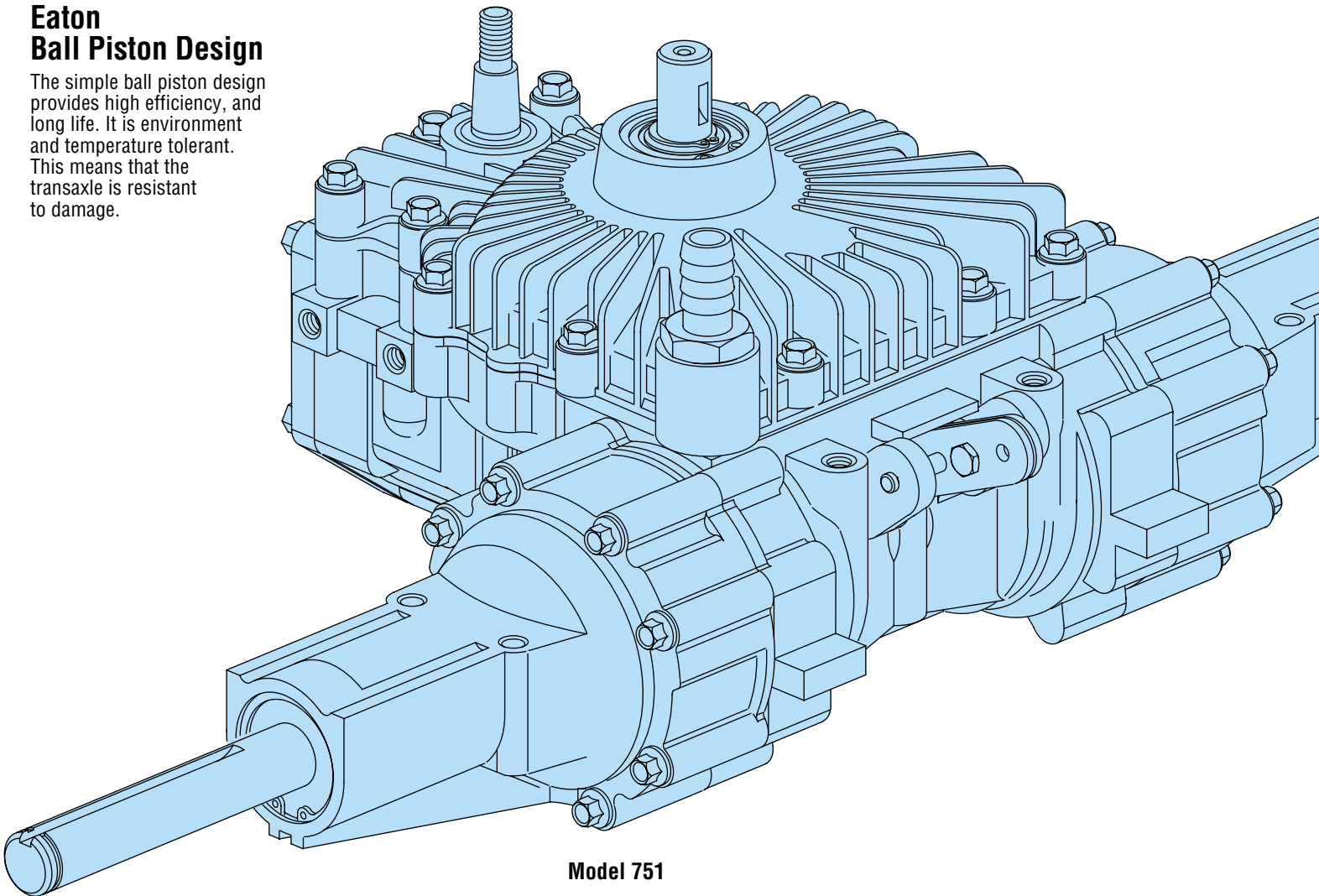

Model 751

**These Transaxles Provide:**

- **Smooth Performance** — Infinitely Adjustable control, delivering smooth operation in both forward and reverse.
- **Easy Operation** — One control provides both forward and reverse, plus speed. No clutch, no synchronizer, no shifting.
- **Hydrostatic Dynamic Braking** — In all kinds of weather, all kinds of terrain, Eaton hydros provide dynamic braking in either forward or reverse.
- **Quiet Operation** — Equipped with special pistons to reduce noise and vibration no matter how tough the job.
- **Trouble Free Performance** — A proven, tested design ensures years of reliable operation with little or no maintenance.

**Transaxles Also Feature:**

- Environmentally protected wet type parking / emergency brake(s), which can be used for full emergency stops in addition to the dynamic braking capability of the hydrostatic transmission.
- Vertical input shaft which allows use with today's popular vertical shaft engine (a horizontal input option is available).
- One pump two motor parallel circuit provides a hydraulic differential system with even power distribution through both wheels.
- 1 inch diameter axle shaft supported with ball bearings provides high axle loading capability.
- The Model 851 has a charge pump with a spin-on oil filter. Port connections provide for a customer supplied oil reservoir. Auxiliary function ports are available.
- Installation mounting points for axle, torsional load, and linkage.

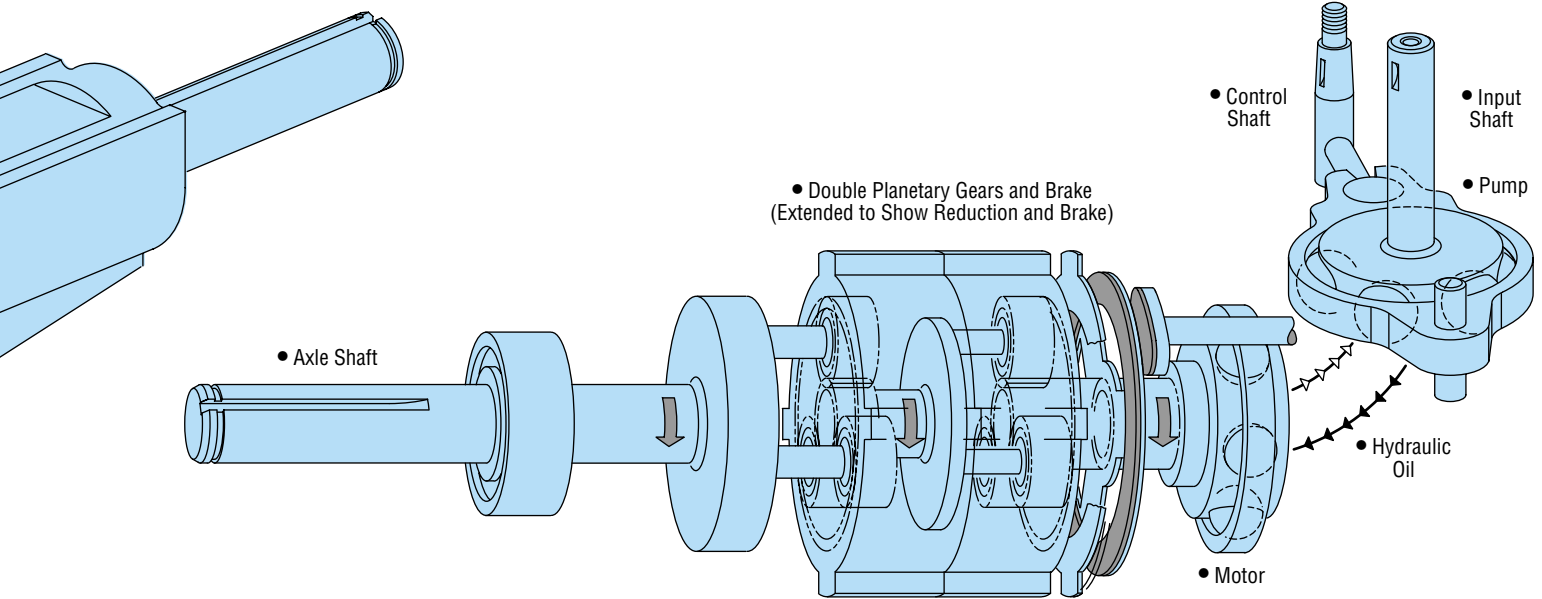

<b>Contents</b>	<b>Page</b>
Model 751 Features and Dimension Data	4- 5
Model 851 Features and Dimension Data	6- 7
Model 771 Features and Dimension Data	8- 9
Model 781 Features and Dimension Data	10-11
Miscellaneous Dimensions — Transaxles	12-13
Axle Shaft Detail Dimensions	14-15
How to Specify Desired Configuration	16
Expansion Tank or Reservoir Connection	17
Complementary Components	17
Application Data Sheet	18-19

# Model 751

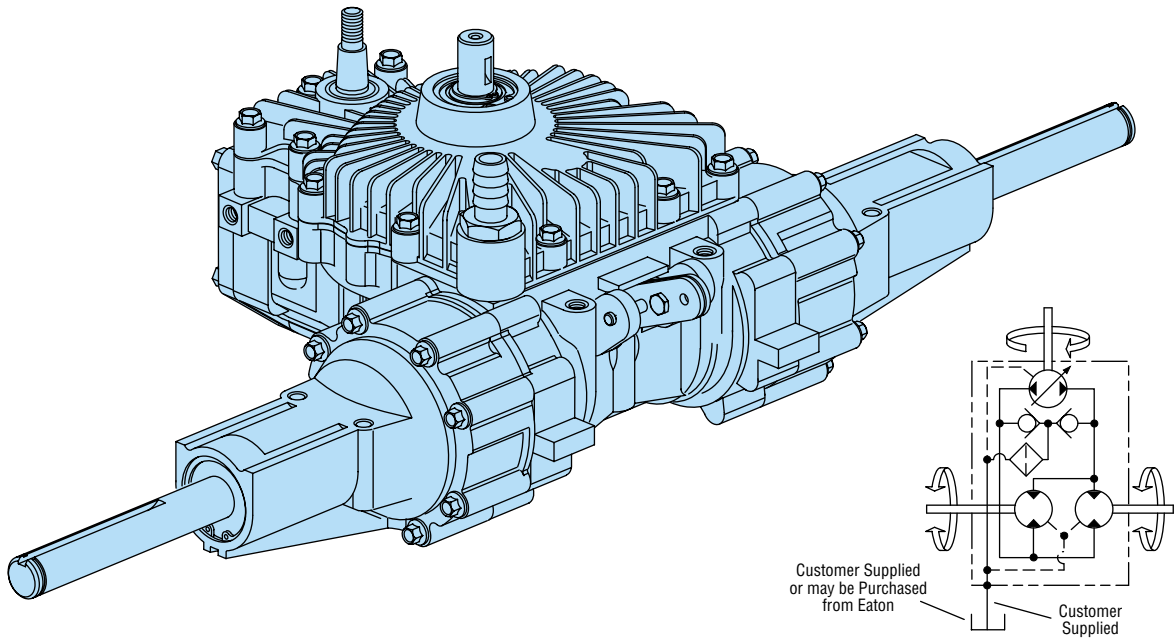

This compact package includes one ball piston pump and two ball piston motors, each with a set of double planetary gears in a single assembly. One piece construction forms a strong frame member for the vehicle. It has a single input control.

### Base Unit Description: Product Number 751-044

Includes 16:1 final drive ratio, CW input shaft rotation, vertical input orientation, environmentally protected wet type parking/emergency brake, plugged side port, 5/8 in. straight barb fitting in main cover, internal filter, externally threaded control shaft, 1 in. dia. output shafts with 1/4 in. square keyway and dump valve.

See model specifications for available options —page 16.

## Operating Specifications

Horsepower, Input — Kw [HP] (Max. Continuous) @ 3600 RPM	3,1 [4.2]
Speed — Input	3600 RPM Max.
— Output	0-110 RPM
Torque, Output — Nm [lb-ft] (16:1 Final Drive)	294 [217] Continuous 413 [305] Intermittent 531 [392] Peak
Weight Over Axle, Max — kg [lb]	900 [408]
Max. Operating Temp. — °C [°F]	82° C [180° F] (w/20W-20 Oil)
Case Pressure, Max.— bar [PSI]	0,8 [12] Intermittent 0,5 [07] Continuous

## Fluid Capacities

Transaxle Case	1700 mL [61 oz]
Recommended Fluids	See Eaton Bulletin No. 3-401

## Oil Filter

Internal

## Control Specifications

Control Torque —Nm [lb-ft] (@ Continuous Rated Axle Torque and Full Stroke)	6,8 [5.0]
Control Shaft Rotation Max.	
Forward	15° 30'
Reverse	15° 30'

## Brakes

Axle Braking Torque	Parking/Emergency Brake Included 407Nm [300 lb-ft] @ 68 kg [150 lb] input to Brake Lever
---------------------	--

## Net Weight

20,9 kg [46 lbs]

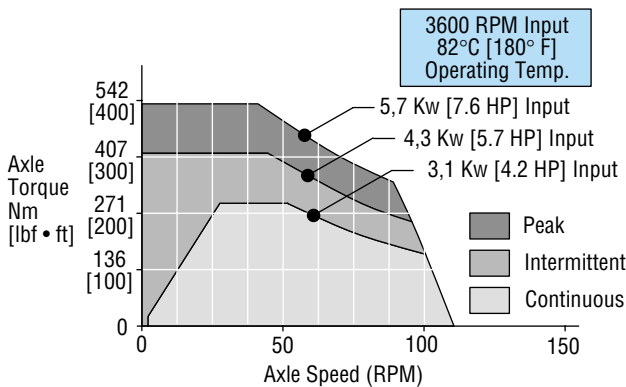

# Model 751 Dimension Data

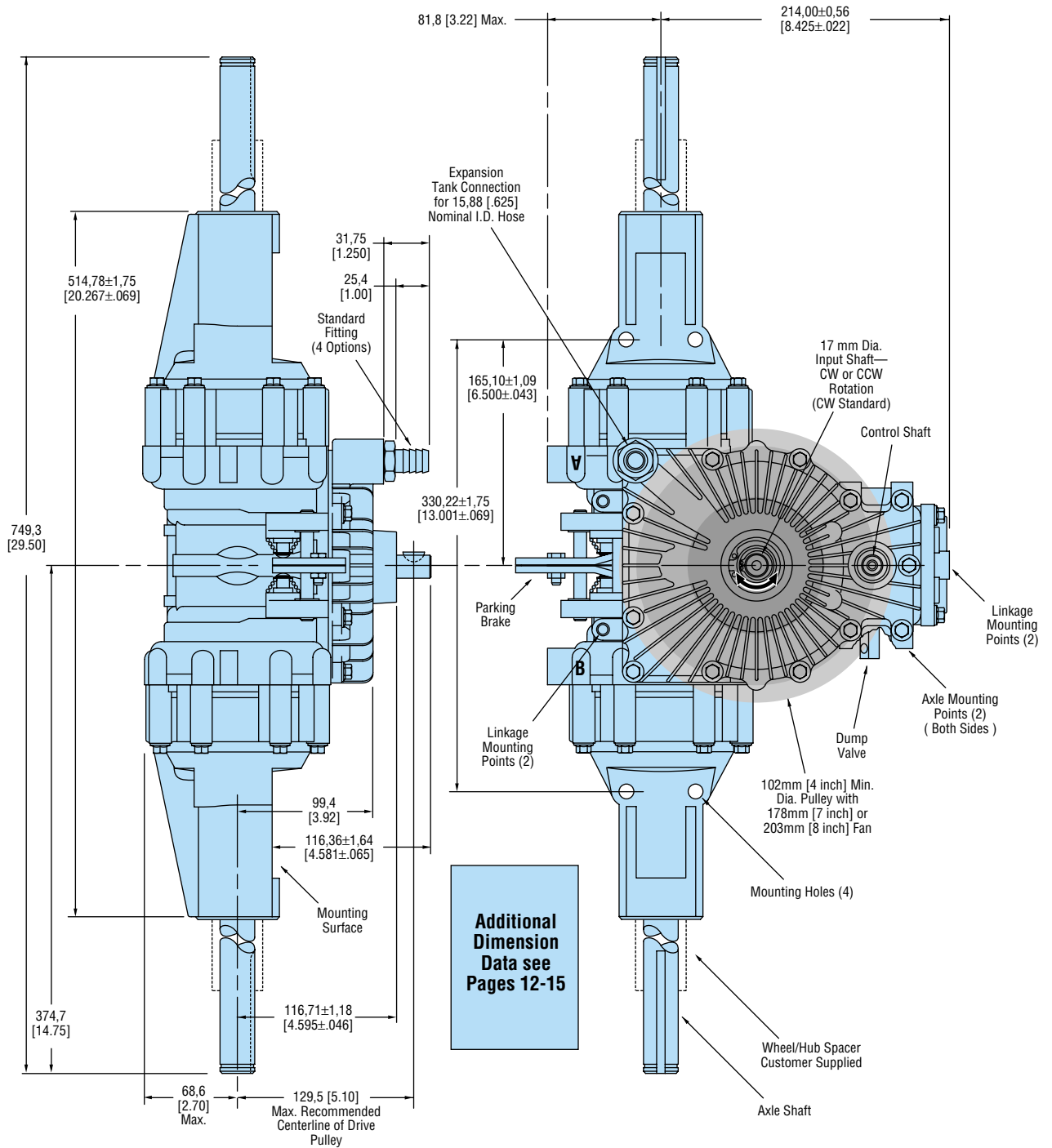



# Model 851

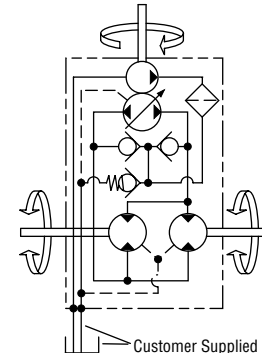
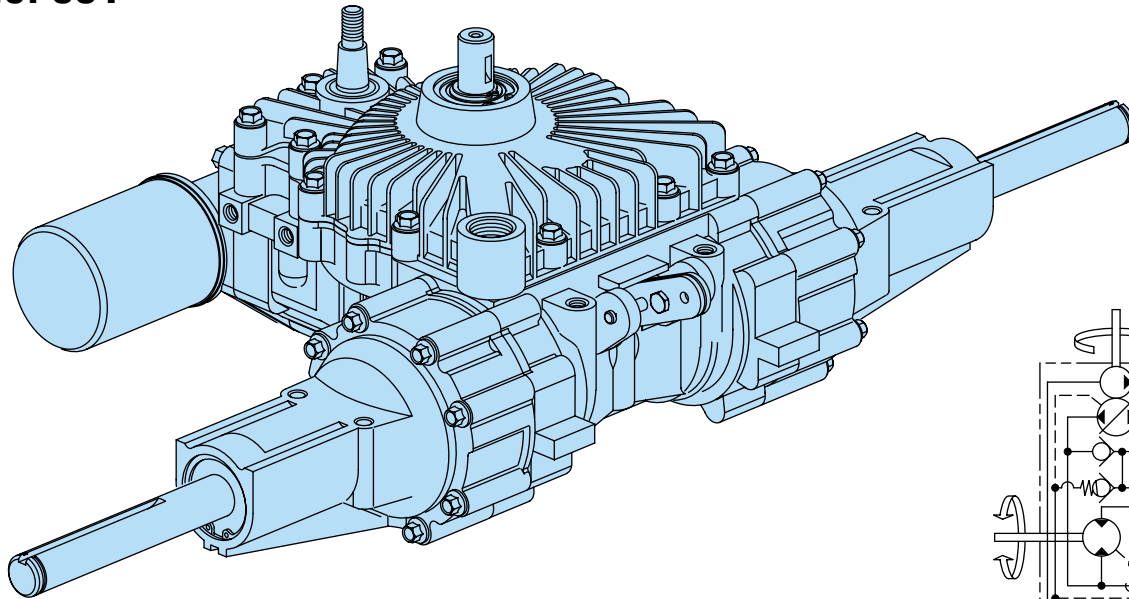

This compact package includes one ball piston pump with a higher displacement than the 751, 771, 781 and two ball piston motors, each with a set of double planetary gears in a single assembly. A charge pump is standard on the 851. One piece construction forms a strong frame member for the vehicle. It has a single input control.

### Base Unit Description: Product Number 851-098

Includes 23:1 final drive ratio, CW input shaft rotation, vertical input orientation, environmentally protected wet type parking/emergency brake, 7/8-14 SAE o-ring ports (side and main cover), integral charge pump, "L" filter base with oil filter, externally threaded control shaft, 1 in. dia. output shafts with 1/4 in. square keyway and dump valve.  
 See model specifications for available options—page 16.

### Operating Specifications

Horsepower, Input — Kw [HP] (Max. Continuous) @ 3600 RPM	4,0 [5.4]
Speed — Input	3900 RPM Max.
— Output	0-112 RPM @3600 RPM
Torque, Output — Nm [lb-ft] (23:1 Final Drive)	439 [324] Continuous 616 [454] Intermittent 790 [583] Peak
Weight Over Axle, Max. — kg [lb]	408 [900]
Max. Operating Temp. — °C [°F]	82° C [180° F] (w/20W-20 Oil)
Case Pressure, Max.— bar [PSI]	0,8 [12] Intermittent 0,5 [07] Continuous
Charge Pump Inlet Pressure —	0,8 bar Absolute [11.7 PSI A] Min. Pressure at Inlet Port under Normal Operating Conditions

### Fluid Capacities

Transaxle Case	2200 mL [74 oz]
Recommended Fluids	See Eaton Bulletin NO. 3-401

### Oil Filter

Spin-on Cartridge, External

### Control Specifications

Control Torque —Nm [lb-ft] (@ Continuous Rated Axle Torque and Full Stroke)	16,3 [12.0]
Control Shaft Rotation Max.	
Forward	17° 37'
Reverse	17° 37'

### Brakes

Parking/Emergency Brake Included	
Axle Braking Torque	507Nm [433 lb-ft] @ 68 kg [150 lb] input to Brake Lever

### Net Weight

21,8 kg [48 lbs]

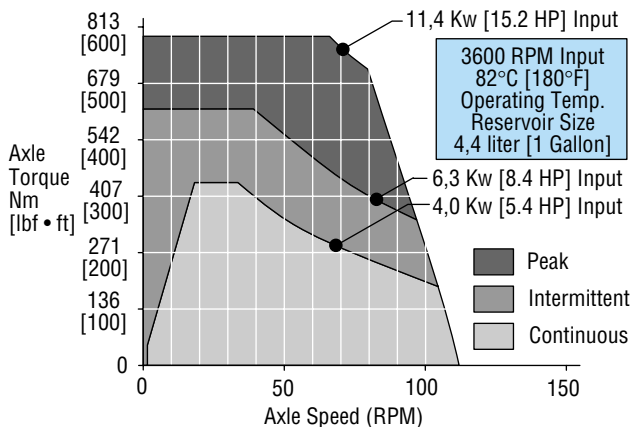

Maximum Continuous Input Horsepower May Be Increased with larger Reservoir or Heat Exchanger — Please Contact your Eaton Representative.

# Model 851 Dimension Data

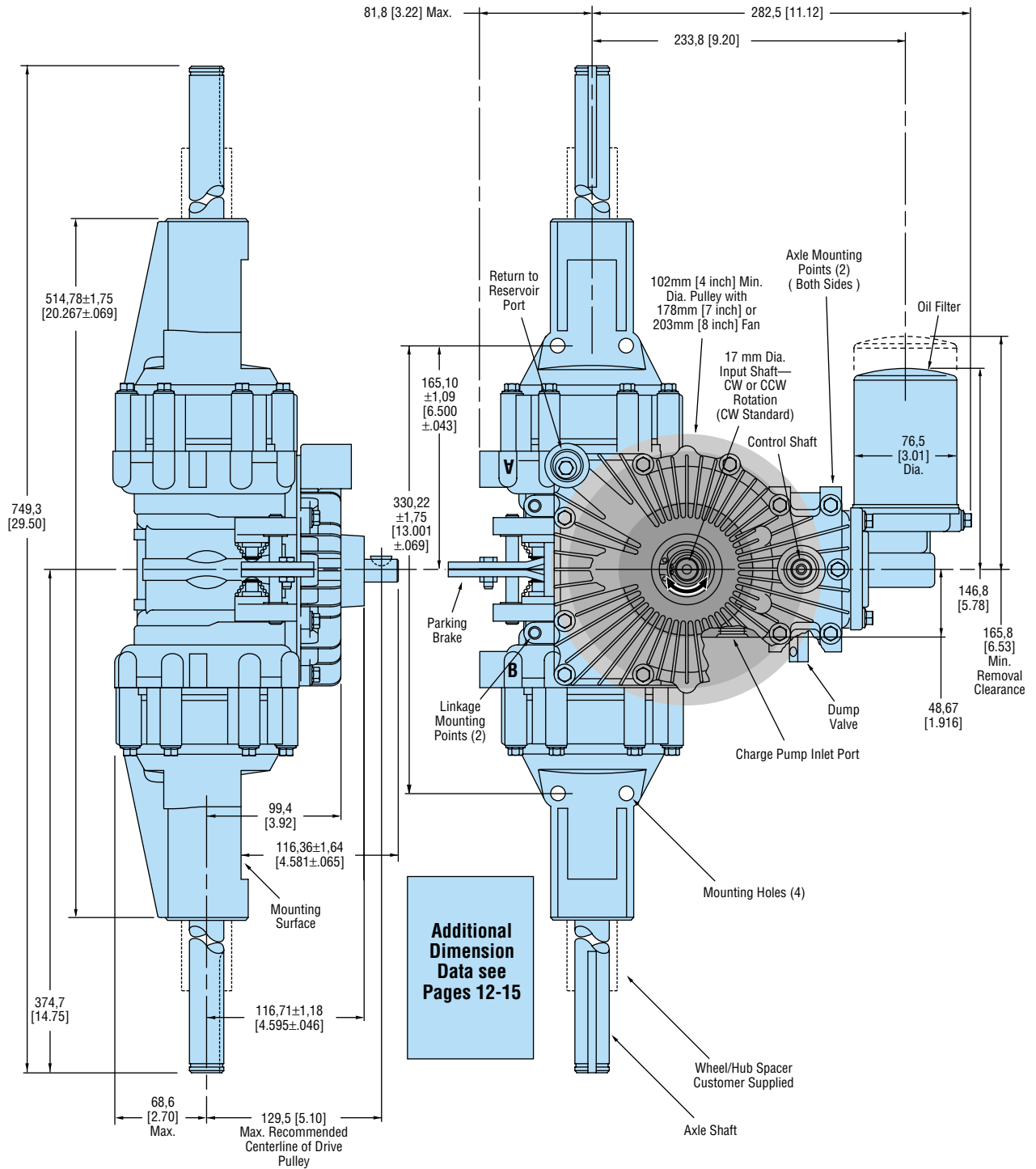

# Model 771

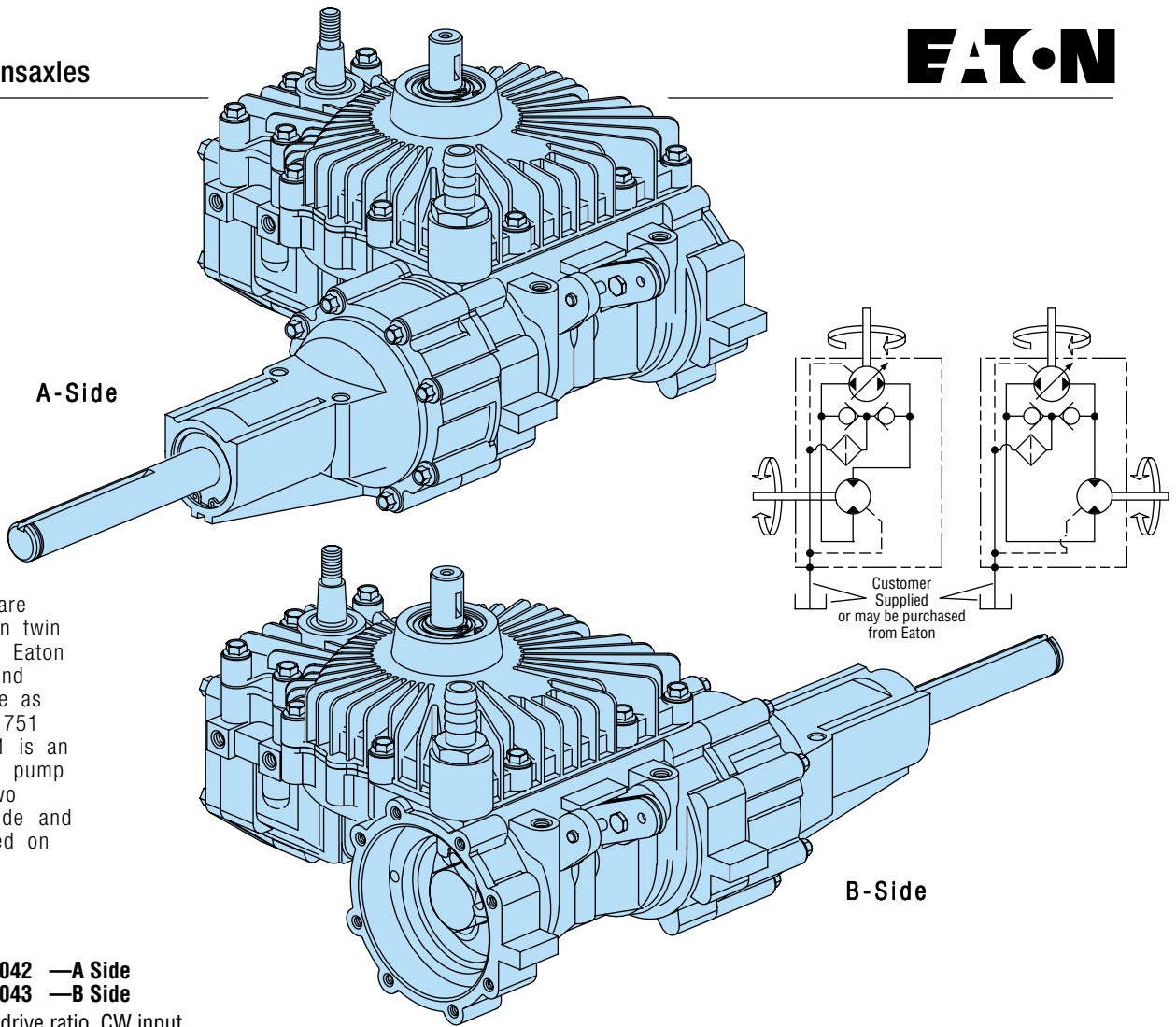

These transaxles are designed for use on twin path vehicles. The Eaton ball piston pump and motor are the same as those used on the 751 transaxles. The 771 is an assembly with one pump and one motor. Two assemblies, a A-Side and B-Side, are required on each vehicle.

**Base Unit Description:**

**Product No. 771-042 —A Side**  
**771-043 —B Side**

Includes 23:1 final drive ratio, CW input shaft rotation, vertical input orientation, environmentally protected wet type parking/emergency brake, plugged side port, 5/8 in. straight barb fitting in main cover, internal filter, externally threaded control shaft, 1 in. dia. output shaft with 1/4 in. square keyway and dump valve. *See model specifications for available options—page 16.*

**Combined Performance of Both Units**

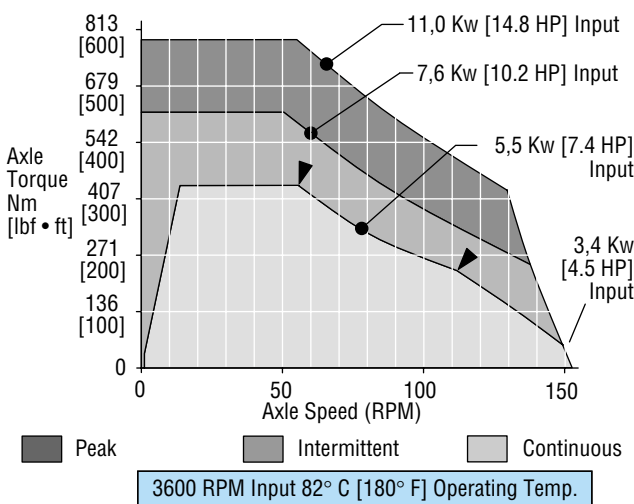

**Combined Operating Specifications**

Horsepower, Input — Kw [HP] (Set)	3,4 [4.5]
(Max. Continuous) @ Full Stroke	5,5 [7.4]
(Max. Continuous) @ 80% Stroke	
Speed — Input	3600 RPM Max.
— Output	0-153 RPM
Axle Torque — Nm [lb-ft] (Set)	439 [324] Continuous
(23:1 Final Drive)	616 [454] Intermittent
	790 [583] Peak
Max. Weight Over Axle — kg [lb]	204 [450] (ea.) 408 [900] (Set)
Max. Operating Temp. — °C [°F]	82° C [180° F] (w/20W-20 Oil)
Max. Case Pressure — bar [PSI]	0,8 [12] Intermittent
	0,5 [07] Continuous

**Fluid Capacities**

Transaxle Case	1700 mL [59 oz] (each)
Recommended Fluids	See Eaton Bulletin NO. 3-401

**Oil Filter**

	Internal (each)
--	-----------------

**Control Specifications**

Control Torque — Nm [lb-ft] (@ Continuous Rated Axle Torque and Full Stroke)	6,8 [5.0] (each)
Control Shaft Rotation Max.	
Forward	15° 30' (each)
Reverse	15° 30' (each)

**Brake**

	Parking/Emergency Brake Included (each)
Axle Braking Torque (Set)	507Nm [433 lb-ft] @ 68 kg [150 lb] input to Brake Lever

**Net Weight**

	16,2 kg [35.8 lbs] (each)
--	---------------------------



# Model 771 Dimension Data

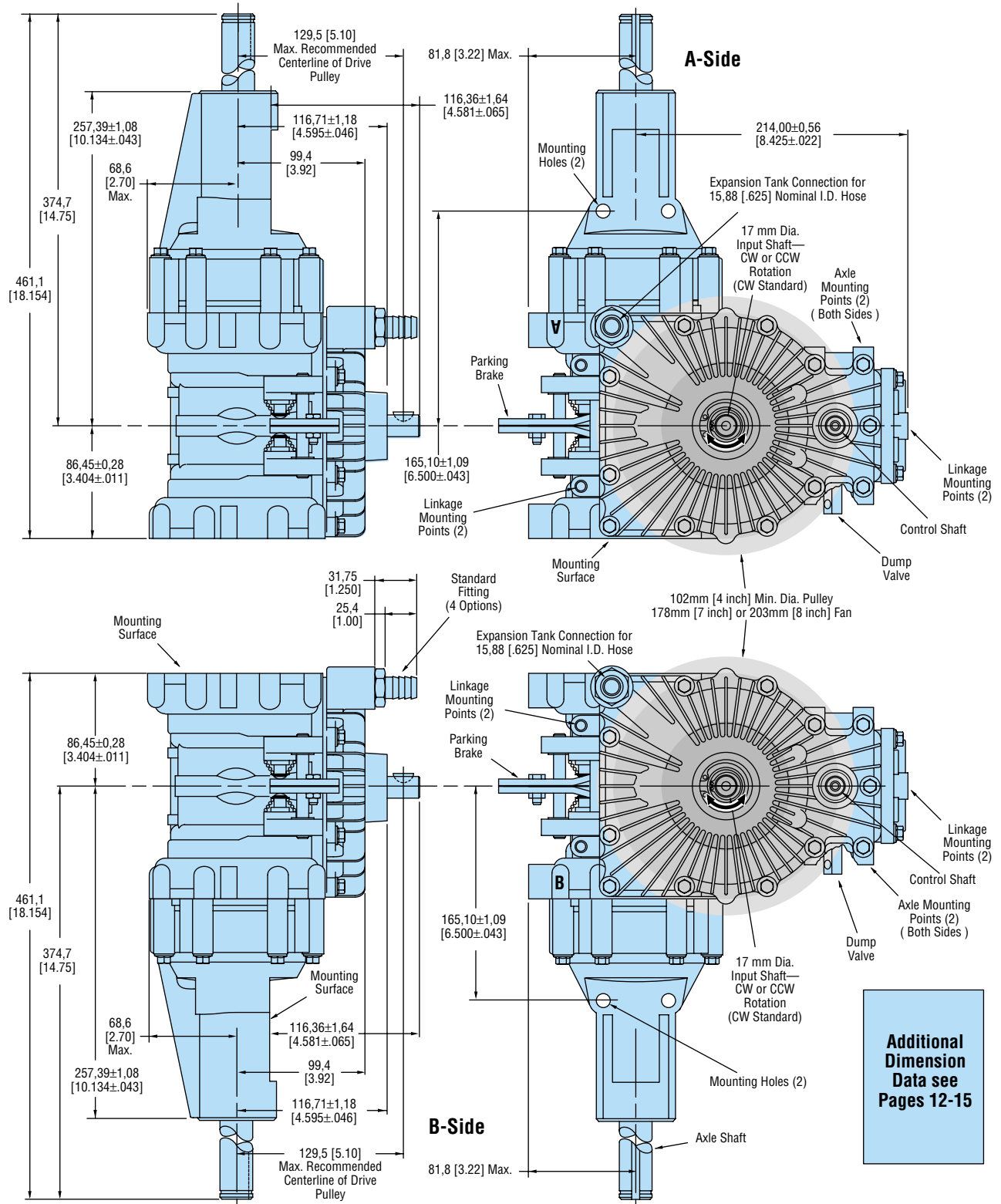

**Additional Dimension Data see Pages 12-15**

# Model 781

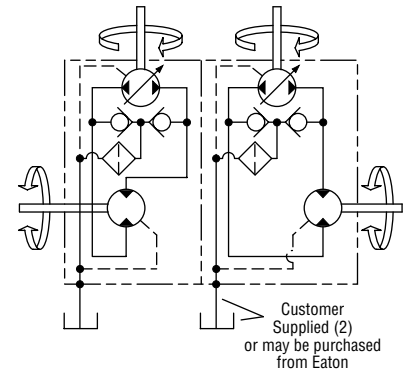
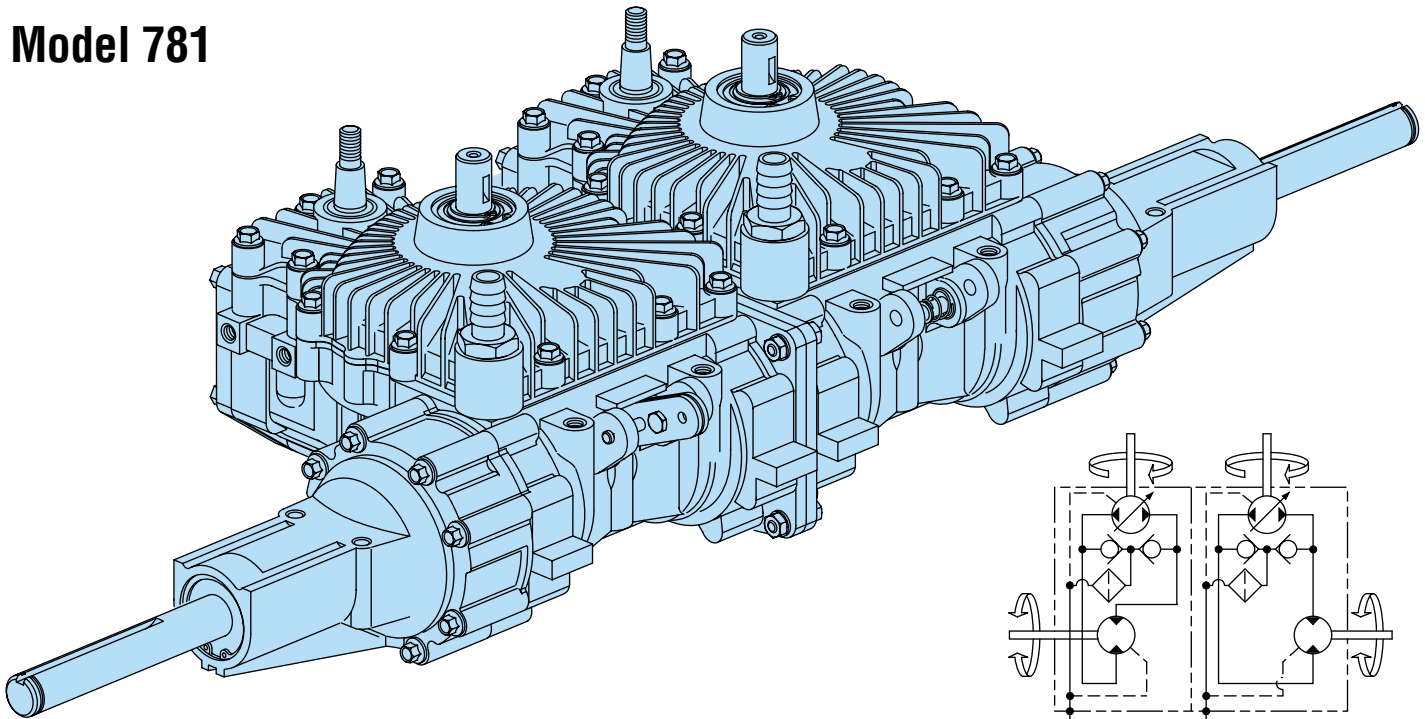

These transaxles are designed for use on twin path vehicles. The Eaton ball piston pumps and motors are the same as those used on the 751, 771 transaxles. The 781 is an assembly of two transaxle halves. Brake control lever A-side standard, one lever actuates both sides.

### Base Unit Description: Product Number 781-017

Includes 23:1 final drive ratio, CW input shaft rotation, vertical input orientation, environmentally protected wet type parking/emergency brake operated by a single lever located on the "A" side, plugged side port, 5/8 in. straight barb fitting in main cover, internal filters, externally threaded control shafts, 1 in. dia. output shafts with 1/4 in. square keyway and two dump valves.

See model specifications for available options—page 16

### Operating Specifications

Horsepower, Input — Kw [HP]	
(Max. Continuous) @ Full Stroke	3,4 [4.5]
(Max. Continuous) @ 80% Stroke	5,5 [7.4]
Speed — Input	3600 RPM Max.
— Output	0-153 RPM
Axle Torque — Nm [lb-ft]	
(23:1 Final Drive)	439 [324] Continuous
	616 [454] Intermittent
	790 [583] Peak
Max. Weight Over Axle — kg [lb]	408 [900]
Max. Operating Temp. — °C [°F]	82° C [180° F] (w/20W-20 Oil)
Max. Case Pressure — bar [PSI]	
	0,8 [12] Intermittent
	0,5 [07] Continuous

### Fluid Capacities

Transaxle Case (Capacity Each Side)	1700 mL [59 oz]
Recommended Fluids	See Eaton Bulletin NO. 3-401

### Oil Filters

### Control Specifications

Control Torque — Nm [lb-ft]	
(@ Continuous Rated Axle Torque and Full Stroke)	6,8 [5.0] (each input)
Control Shaft Rotation Max.	
Forward	15° 30'
Reverse	15° 30'

### Brakes

Axle Braking Torque	Parking/Emergency Brake Included
	507Nm [433 lb-ft] @
	68 kg [150 lb] input to Brake Lever
	31 kg [68 lbs]

### Net Weight

### Performance Curve

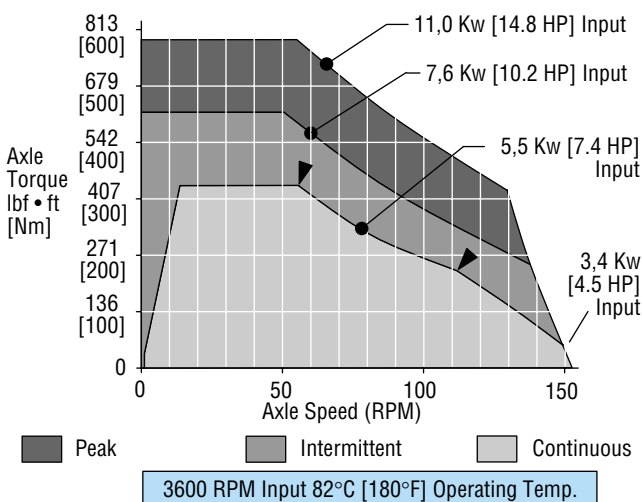

# Model 781 Dimension Data

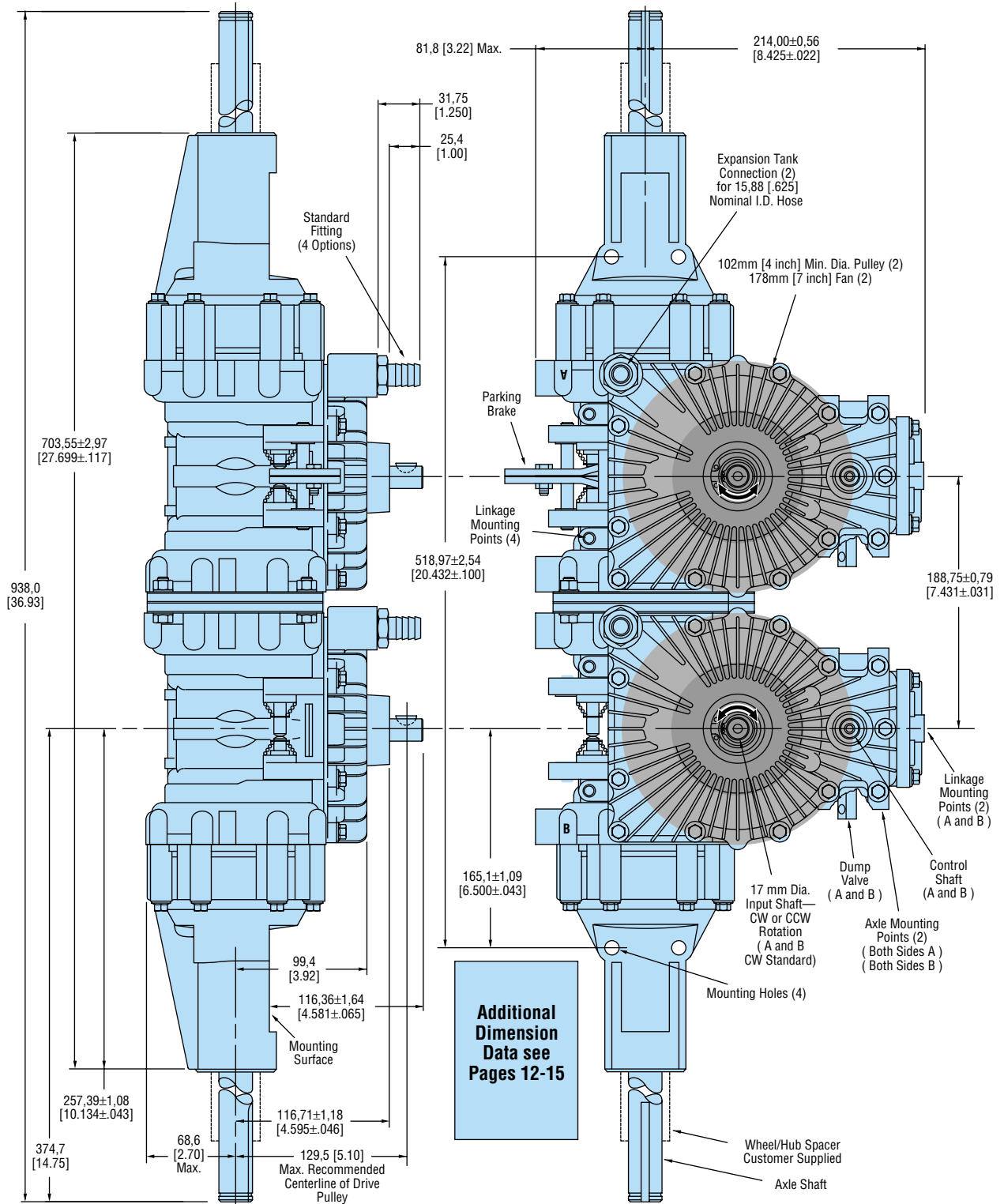

# Miscellaneous Dimensions — Transaxles

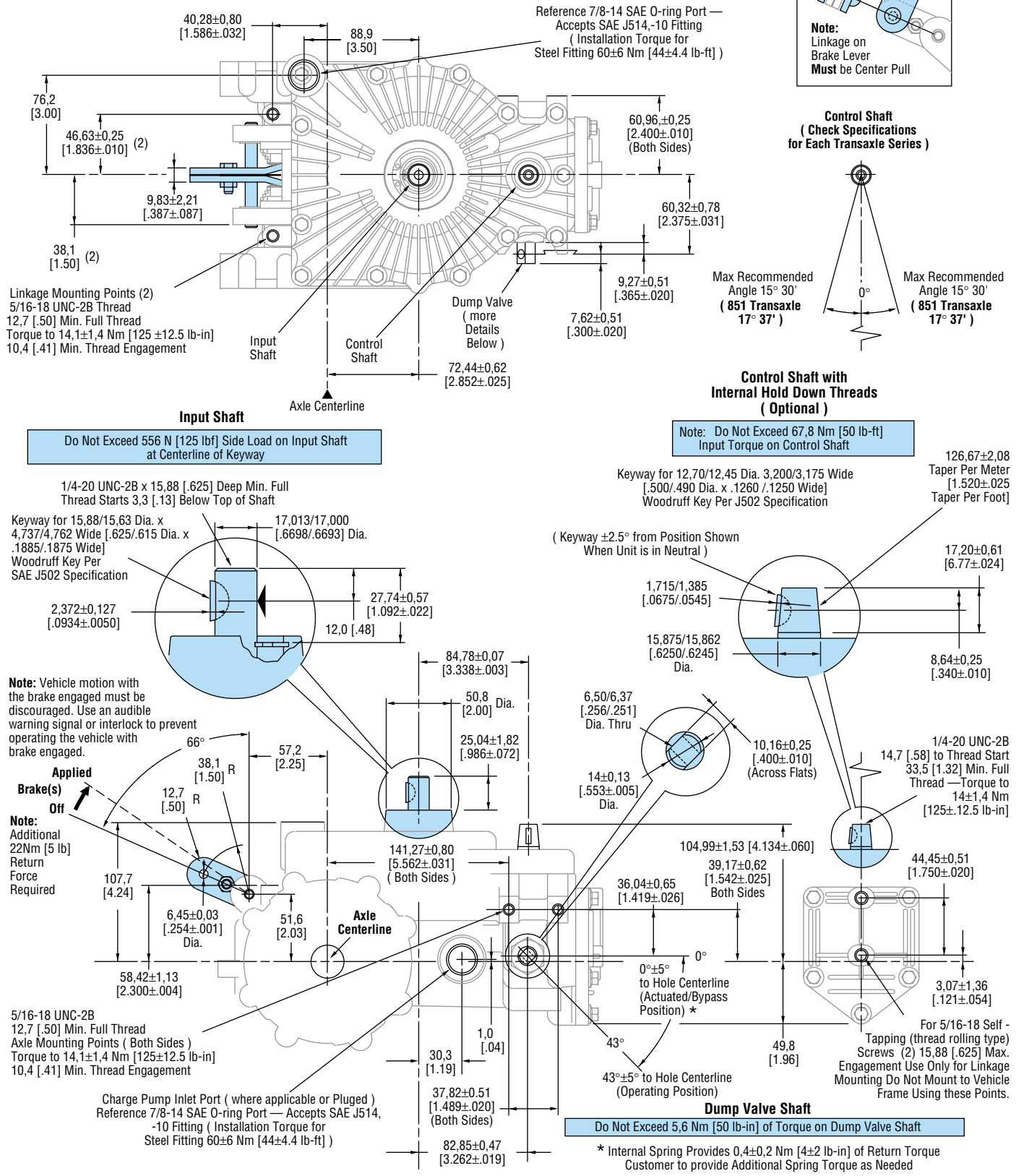

# Miscellaneous Dimensions — Transaxles

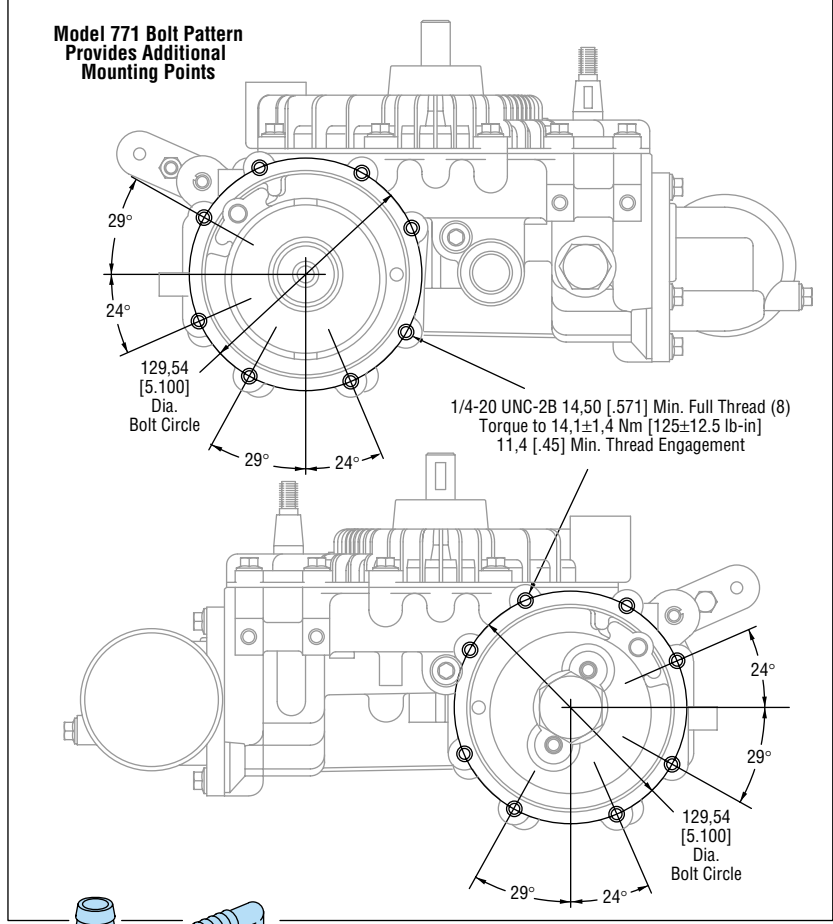
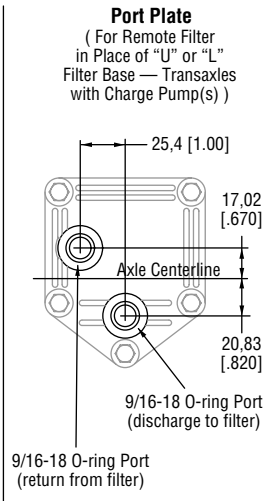
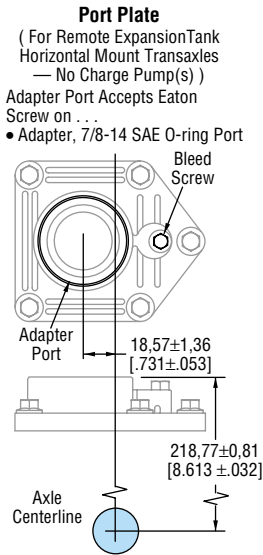

**Control Shaft with External Hold Down Threads ( Standard )**

**Note: Do Not Exceed 67,8 Nm [50 lb-ft] Input Torque on Control Shaft**

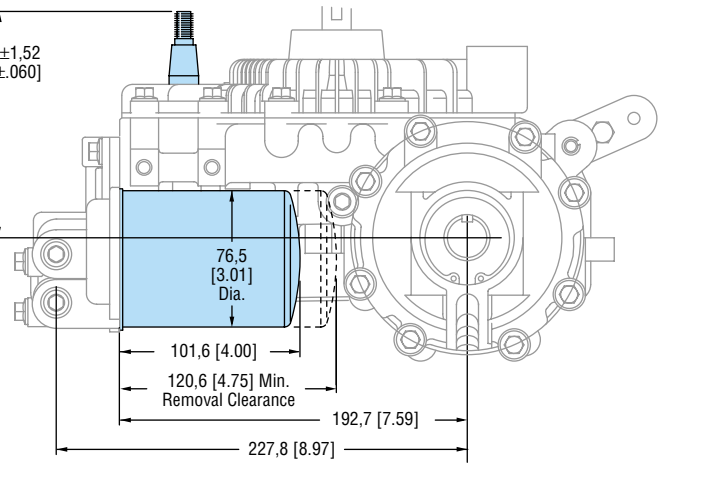
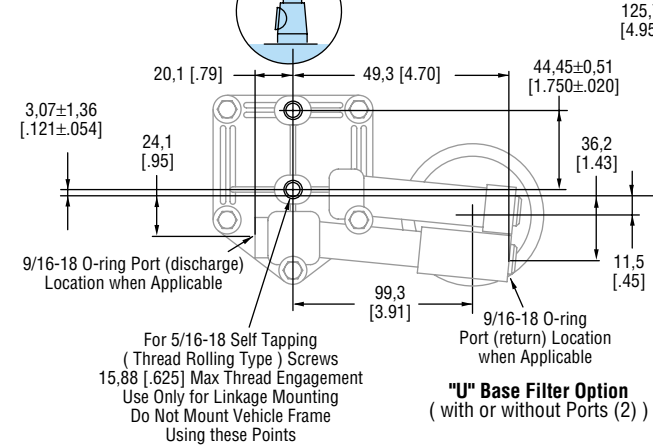
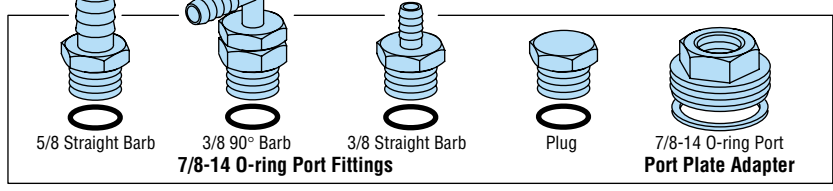
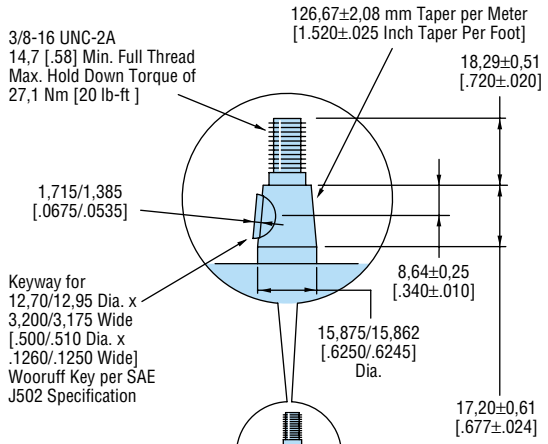



# Axle Shaft Detail Dimensions

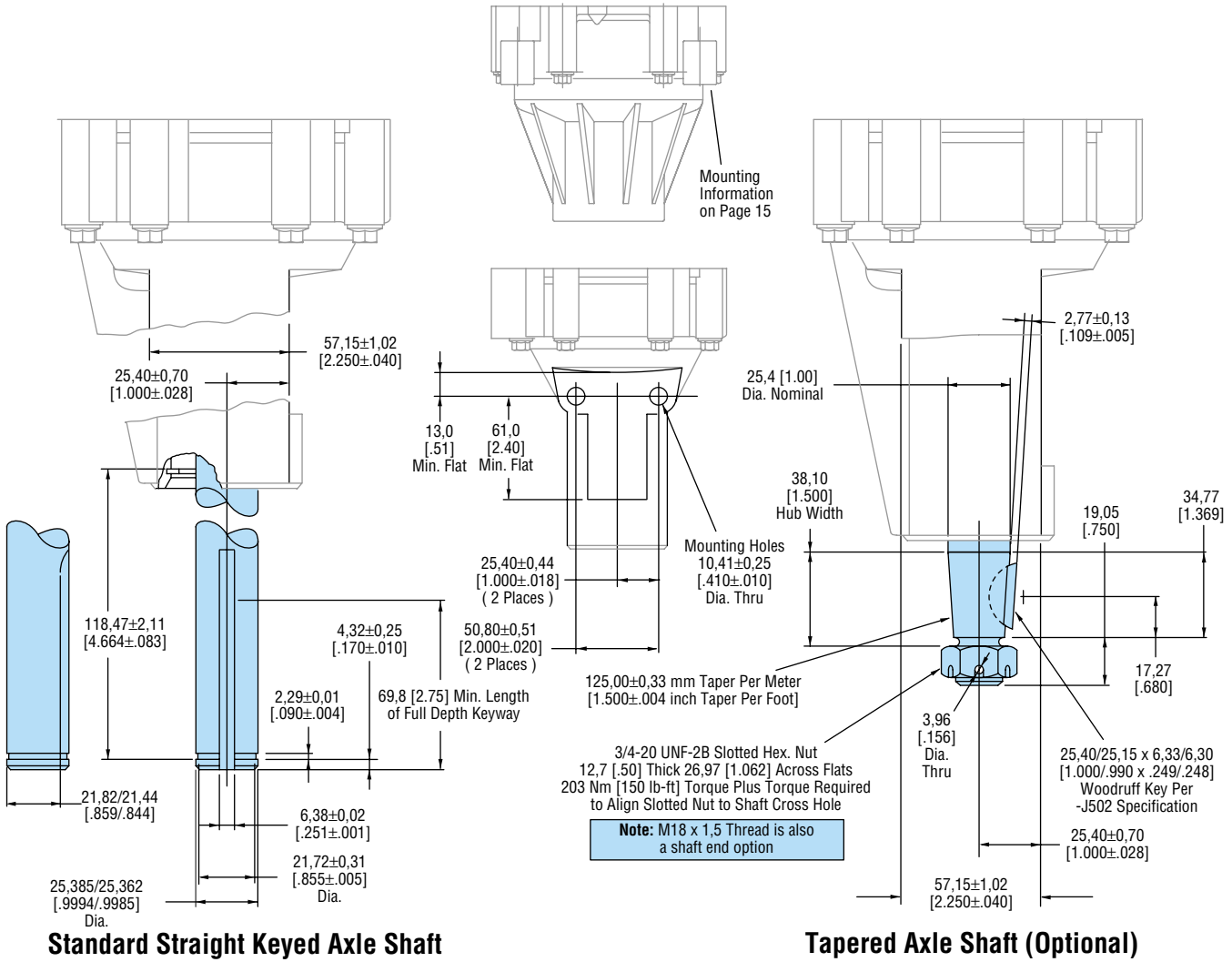

## Optional Shaft End with Internal Thread

**3/8-16**  
22,35 [.880]  
Min. Full Thread



**Straight Axle Shaft End Thread**

**M10**  
14,99 [.590]  
Min. Full Thread



**Straight Axle Shaft Metric End Thread**

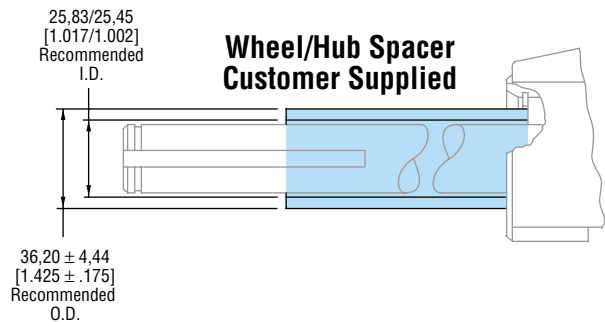

## Control Arm Dimensions for 751, 851, 771 and 781 Transaxles

Control arms for the Transaxle must be manufactured by the customer because of the variety of control mechanisms that can be used on applications.

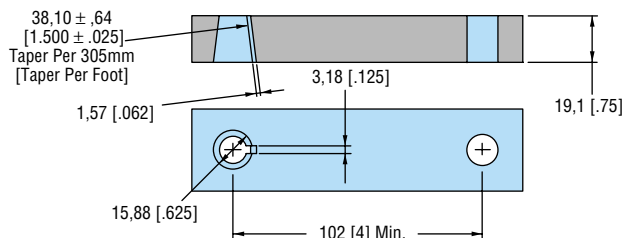

## Short Axle Shaft Detail Dimensions

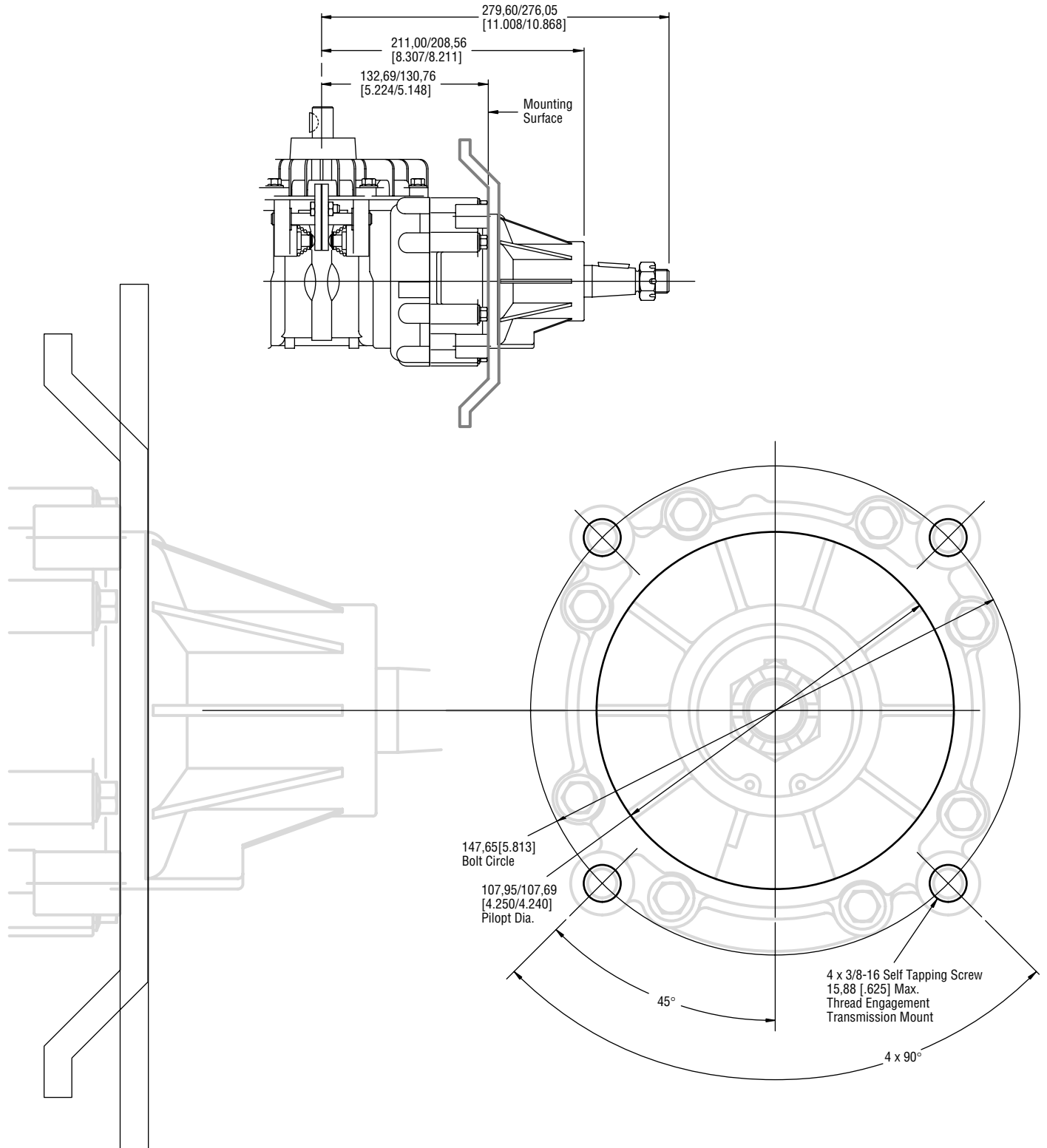

## How to Specify Desired Configuration

**Note:** Use the Model Code for specifying and communicating desired configuration. Order by Product Number Only (e.g. 751-XXX), contact your Eaton representative to get product number assignment (subject to application review and confirmation of pricing).

**Example Model Code**

851			C	1	A	1	B	4	4	D	1	AA		1	00	
1	2	3	4	5	6	7	8	9	10	11	12	13	14	15	16	17

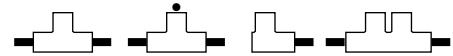

Position	Feature	Code	Option	751	851	771	781
1,2,3	Series	751 851 771 781	Transaxle 8,15 cm <sup>3</sup> /r [.497 in <sup>3</sup> /r] Displ. Pump Transaxle 11,9 cm <sup>3</sup> /r [.728 in <sup>3</sup> /r] Displ. Pump Single Path Transaxle Assy. 8,15 cm <sup>3</sup> /r [.497 in <sup>3</sup> /r] Displ. Pump Dual Path Transaxle Assy. 8,15 cm <sup>3</sup> /r [.497 in <sup>3</sup> /r] Displ. Pump	Standard — — —	— Standard — —	— — Standard —	— — — Standard
4	Final Drive Ratio	B C D	16:1 23:1 23:1 Steel Secondary Sun and Planet Gears	Standard Option —	— Standard Option	— Standard Option	— Standard Option
5	Input Rotation	1 2	Clockwise Rotation Counterclockwise Rotation	Standard Option	Standard Option	Standard Option	Standard Option
6	Mounting	A B	Vertical (Input Shaft Vertical) Horizontal (Input Shaft Horizontal)	Standard Option	Standard Option	Standard Option	Standard Option
7	Brake Option	1 4 6	Brake Brake Lever A Side Only (Actuates Both Sides) Brake Lever B Side Only (Actuates Both Sides)	Std — —	Std — —	Std — —	— Std Option
8	Charge Pump	A B C	No Charge Pump Charge Pump Charge Pump — High Pressure 19 bar @ 1,9 L/min @ 49° C [275 PSI @ .5 GPM @120° F]	Standard Option Option	— Standard Option	Standard Option Option	Standard Option Option
9	Side Port	1 2 4	Plug 3/8 Straight Barb Fitting 7/8-14 SAE O-ring Port (Accepts SAE J514, -10 Fitting)	Standard Option Option	— — Standard	Standard Option Option	Standard Option Option
10	Cover Port	1 2 4 B C	3/8 90° Barb Fitting 3/8 Straight Barb Fitting 7/8-14 SAE O-ring Port (Accepts SAE J514, -10 Fitting) 5/8 Straight Barb Fitting Plug	Option Option Option Standard Option	— — Standard Option —	Option Option Option Standard Option	Option Option Option Standard Option
11	Filter Base/ Valve Cover	G B C D E J	Valve Cover with Filter Port Plate for Remote Filter (No Internal Filter) “L” Filter Base with Filter “U” Filter Base with Filter “U” Filter Base with Ports (2), Filter Port Plate with 1-7/8 12 (port and fittings for Horizontal Mount)	Standard Option Option Option Option Option	— Option Standard Option Option —	Standard Option Option Option Option Option	Standard Option Option Option Option Option
12	Control Shaft	1 2	External Threads Internal Threads	Standard Option	Standard Option	Standard Option	Standard Option
13, 14	Output Shafts	AA BL BM BK	1 inch Straight Keyed Shaft (Standard) — — 749,3 [29.50 ] overall width (Standard 751 and 851) — 461,1 [18.154] overall width (Standard 771 — A-Side) — 461,1 [18.154] overall width (Standard 771 — B-Side) — 938,0 [36.93 ] overall width (Standard 781)	Standard — — —	Standard — — —	— Standard Standard —	— — — Standard
15	Dump Valves	1 2	Dump Valve(s) No Dump Valve	Standard Option	Standard Option	Standard Option	Standard Option
16, 17	Special Features	00 AE	No Special Features Wide Neutral Band	Standard Option	Standard Option	Standard Option	Standard Option

**Note:** Dimensions are in millimeter, inch designation in brackets [ ].  
**For Optional Shaft Lengths, Tapered or Tapped Ends, Contact your Eaton Representative.**  
**Other:** ( Describe Desired Product Feature Not Listed )

## Expansion Tank or Reservoir Connections

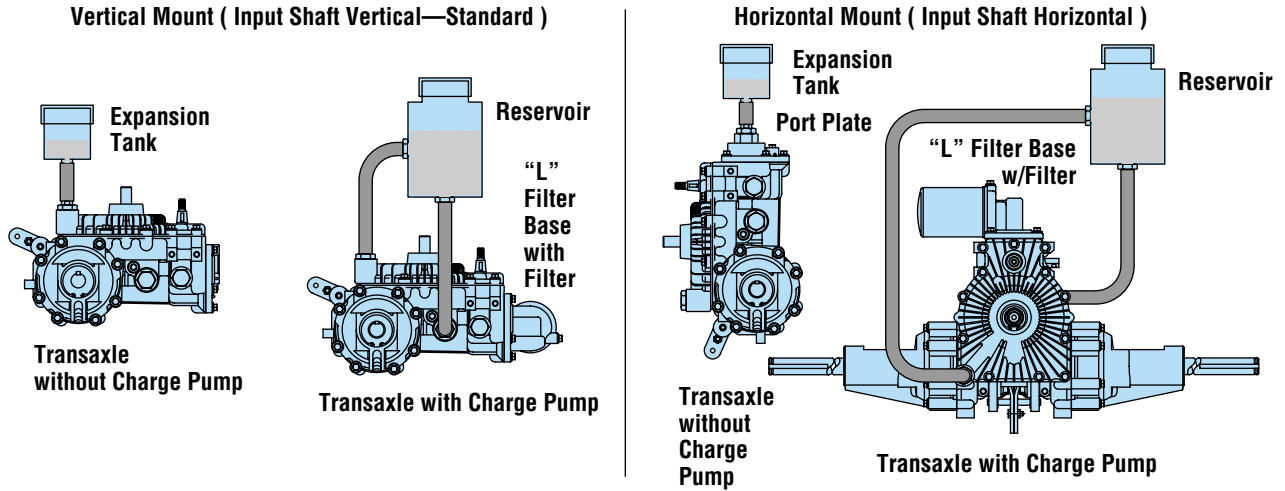

## Complementary Components

### Fan Components

P/N	Description	Fan, mm [in]	*Input Rotation	Models
106014-000	Fan only, no sheave S/A	5 Blade, 203 [8]	CW	751, 771, 851
106015-000	Fan only, no sheave S/A	5 Blade, 203 [8]	CCW	751, 771, 851
106016-000	Fan only, no sheave S/A	10 Blade, 178 [7]	CW	751, 771, 781, 851
106017-000	Fan only, no sheave S/A	10 Blade, 178 [7]	CCW	751, 771, 781, 851

### Filter Components

P/N	Description	Nominal Rating	Diameter, mm [in]	Length, mm [in]	Models
110007-000	No Bypass	10 micron	76 [3.000]	67 [2.640]	751, 771, 781, 851
105258-000	No Bypass	10 micron	94 [3.680]	83 [3.250]	751, 771, 781, 851
103144-000	No Bypass	10 micron	77 [3.023]	120 [4.718]	751, 771, 851
111729-000	1,72 bar (25 psi) Bypass	10 micron	77 [3.023]	120 [4.718]	751, 771, 851
111726-000	2 bar (29 psi) Bypass	10 micron	76 [3.000]	67 [2.640]	751, 771, 781, 851

### Reservoir/Expansion Tanks (for non-charge pump units only)

P/N	Description	Models
104948-000	Reservoir/Cover/Gasket/Shipping Cap w/ two 3/8" ports	751, 771, 781, 851
104973-000	Reservoir/Cover/Gasket w/ two 3/8" ports	751, 771, 781, 851
106011-000	Expansion Tank/Cover/Gasket w/ one 5/8" port	751, 771, 781, 851
106708-000	Expansion Tank/Cover/Gasket w/ one 5/8" port and oil symbol molded in cover	751, 771, 781, 851
111472-000	Expansion Tank/Cover w/ one 5/8" port	751, 771, 781, 851

\* Based upon input rotation to the transmission or transaxle facing input drive shaft

**Application Data Sheet**

Date \_\_\_\_\_

**Transaxle / Transmission**

Application No. \_\_\_\_\_

MPS No. \_\_\_\_\_

Company Name \_\_\_\_\_ Completed By \_\_\_\_\_

Address \_\_\_\_\_

City \_\_\_\_\_ Phone No. \_\_\_\_\_

State \_\_\_\_\_ Zip \_\_\_\_\_ Contact \_\_\_\_\_

**Vehicle Information**

Lawn Tractor  Yard Tractor  Garden Tractor  Sulky Type  Walk Behind  ZTR  Other

Vehicle Description \_\_\_\_\_

Vehicle Weight \_\_\_\_\_ Gross \_\_\_\_\_ ; Max. Weight on Drive Axle \_\_\_\_\_

Approx. CG Height with Operator @ Gross Weight: \_\_\_\_\_ lb

Vehicle Ground Speed: Road Range \_\_\_\_\_ MPH Work Range \_\_\_\_\_ MPH

Wheel Base \_\_\_\_\_ Inch

Max. Desired Grade ability \_\_\_\_\_ %; Coefficient of Rolling Resistance \_\_\_\_\_

Wheel Slip Yes  No  Coefficient of Traction (adhesion) \_\_\_\_\_

Tread Type: Turf  Chevron  Knobby

Drive Tire: Diameter \_\_\_\_\_ in. Loaded Radius (including optional tires) \_\_\_\_\_

Drive Axle Track \_\_\_\_\_

Power Source: Gas  Diesel  Engine Make and Model \_\_\_\_\_

Torsional Damper? \_\_\_\_\_ Aux. Brg. Support of Axle Shaft \_\_\_\_\_

Horsepower Rating (@Full Loaded Governed Speed) \_\_\_\_\_ @ \_\_\_\_\_ RPM

Vehicle Brakes: Dynamic  Parking  Brake Type: Drum  Disc  Other \_\_\_\_\_

**Vehicle Attachments:**

Mower Size \_\_\_\_\_ In. Weight \_\_\_\_\_ lb

Tiller Size \_\_\_\_\_ In. Weight \_\_\_\_\_ lb

Rotation (with or against travel) \_\_\_\_\_

Snow Blower Size \_\_\_\_\_ In. Weight \_\_\_\_\_ lb

Dozer Blade Size \_\_\_\_\_ In. Weight \_\_\_\_\_ lb

Bucket \_\_\_\_\_ ft<sup>3</sup> Weight \_\_\_\_\_ lb

Edger (estimated thrust) \_\_\_\_\_ lbs. Weight \_\_\_\_\_ lb

Plow Size \_\_\_\_\_ In. Weight \_\_\_\_\_ lb

Type Hitch \_\_\_\_\_

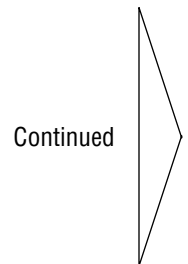



# Hydrostatic Transaxles



Grass Bagger Attached on Tractor      Yes       No       Weight of Attached Bagger Assembly      \_\_\_\_\_ lb

Bushel Capacity      \_\_\_\_\_      Approximate Weight Full      \_\_\_\_\_ lb

Trailer Type Grass Catcher      One Wheel       Two Wheel

Trailer Bushel Capacity      \_\_\_\_\_      Approximate Weight Full      \_\_\_\_\_ lb

Wheel Weights      \_\_\_\_\_      Other (describe)      \_\_\_\_\_

## Input to Transaxle / Transmission

Input Rotation (Facing Input Drive Shaft): CW       CCW

Input Shaft Position:      Vertical \_\_\_\_\_      Horizontal \_\_\_\_\_

Input Drive: Belt \_\_\_\_\_      Direct Coupling \_\_\_\_\_      Other \_\_\_\_\_

   Input Drive Ratio      \_\_\_\_\_

Transaxle Control:      Hand Lever \_\_\_\_\_      Foot Pedal \_\_\_\_\_      Other (describe) \_\_\_\_\_

Motor Displacement:      \_\_\_\_\_

Oil Reservoir Capacity:      \_\_\_\_\_

Oil Type      \_\_\_\_\_

## Duty Cycle:

Describe Operating Conditions (% time in hours per attachment)      \_\_\_\_\_

\_\_\_\_\_

\_\_\_\_\_

\_\_\_\_\_

\_\_\_\_\_

Comments      \_\_\_\_\_

\_\_\_\_\_

\_\_\_\_\_

Control Lever Length	_____ inch	Type of:	Neutral/Brake Interlock	_____
Control Lever Weight on Shaft	_____ oz		Engine Shut-Off	_____
Dump Valve Lever Length	_____ inch		Input Disengagement	_____
Weight on Shaft	_____ oz		Neutral Return	_____
Input Pulley Dia.	_____ inch		Return Force	_____
			Stroke Mechanism	_____
			Foot Pedal,	_____
			Hand Lever,	_____
			Twist Grip	_____



Eaton Corporation is a global manufacturer of highly engineered products that serve industrial, vehicle, construction, commercial, aerospace and semiconductor markets. Principal products include hydraulic products and fluid connectors, electrical power distribution and control equipment, truck drivetrain systems, engine components, ion implanters and a wide variety of controls. Headquartered in Cleveland, Ohio, the company has 63,000 employees and 195 manufacturing sites in 23 countries around the world. Eaton's sales for 1999 were \$8.4 billion.

Information contained in this catalog is accurate as of the publication date and is subject to change without notice. Performance values are typical values. Customers are responsible for selecting products for their applications using normal engineering methods.

### **Eaton Hydraulics**

14615 Lone Oak  
Eden Prairie, MN 55344-2287  
Telephone: (888) 258-0222  
Fax: (952) 974-7722  
[www.eatonhydraulics.com](http://www.eatonhydraulics.com)

46 New Lane, Havant  
Hampshire P09 2NB  
England  
Telephone (44) 23 92 486 451  
Fax: (44) 23 92 487 110



**Quality System Certified**  
Products in this catalog are  
manufactured in an  
ISO-9001-certified site.

