

**EAT•N**

**Hydraulics**

## **Repair Information**

Model 70442 Propulsion Piston Pumps

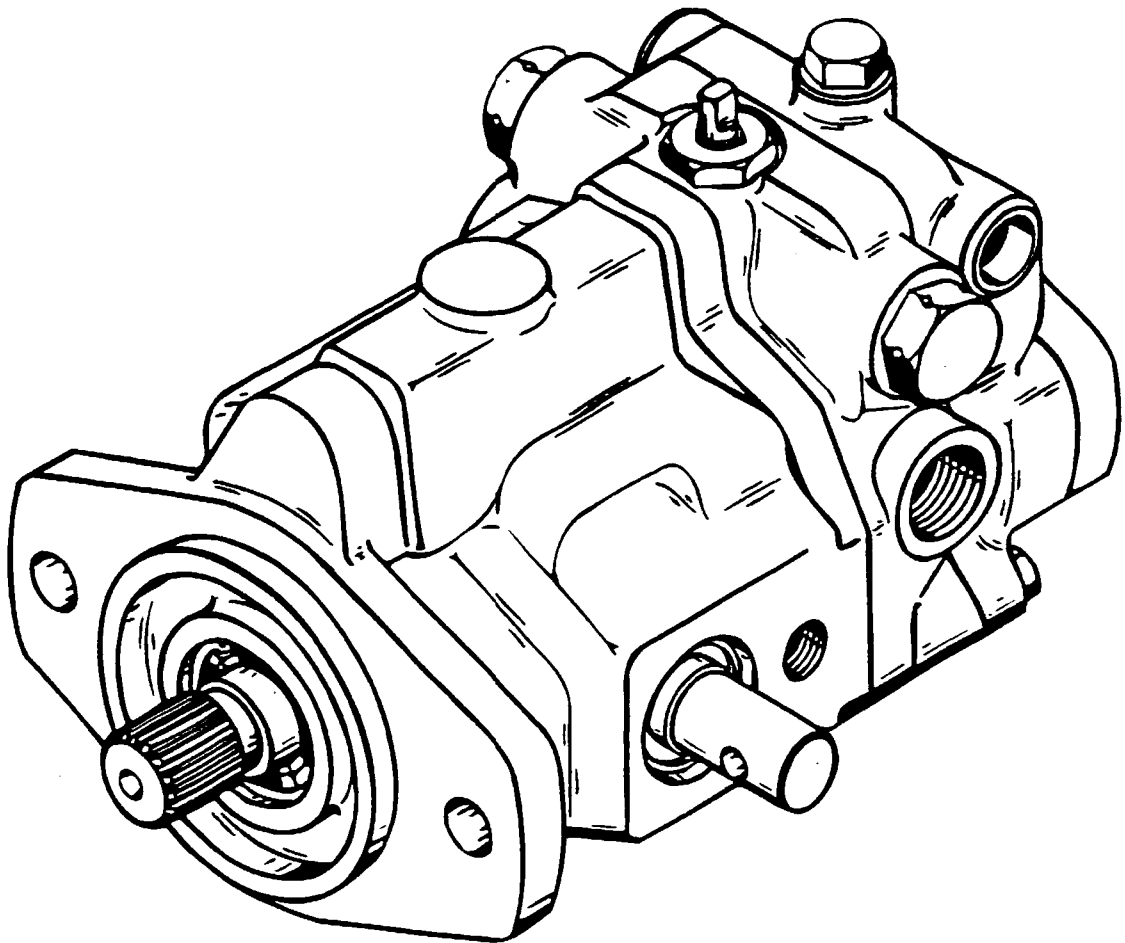

**EAT•N**

# Parts Drawing

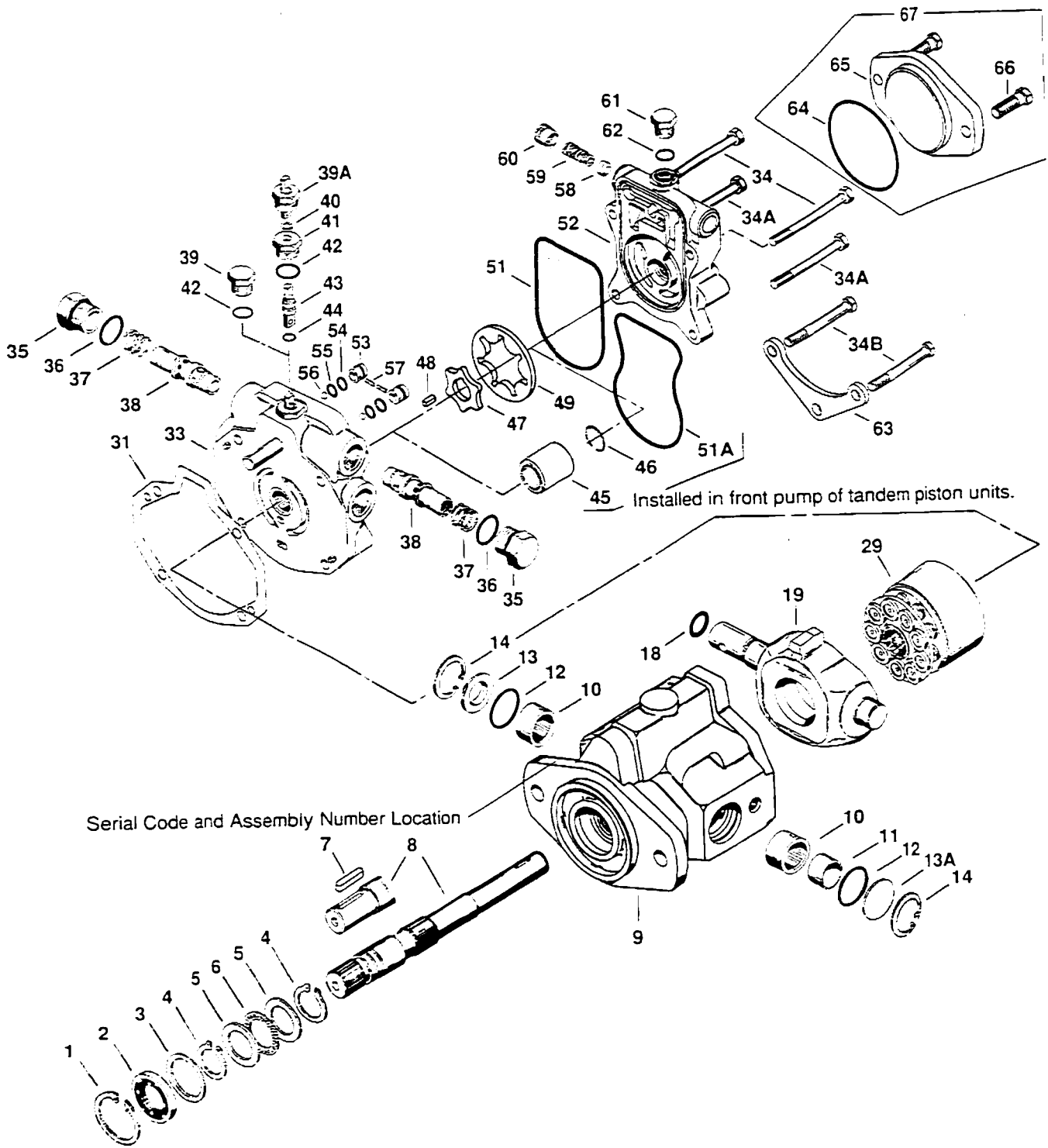

## Parts List

Item No.	Description	Qty
+ 1	Retaining Ring	1
+ 2	Shaft Seal	1
3	Washer	1
+ 4	Retaining Ring	2
5	Bearing Race	2
6	Bearing	1
7	Key	1
8	Drive Shaft	1
9	Housing Assembly	1
10	Bearing	2
11	Inner Race	1
+ 12	O-ring, 3/32 in. x 1-7/16 in. I.D. [2,38mm x 36,5mm I.D.]	2
13	Sleeve Cover	1
13A	Trunnion Cover	1
14	Retaining Ring	2
+ 18	O-ring, 3/32 in. x 13/16 in. I.D. [2,38mm x 20,64mm I.D.]	1
19	Camplate	1
29	Rotating Kit Assembly	1
31	Housing Gasket	1
33	Backplate Assembly	1
34	Cap Screws	2
34A	Cap Screws	2
34B	Cap Screws (used w/mounting bracket)	2
35	Plug Assembly	2
+ 36	O-ring, in. 3/32 in. x 7/8 I.D. [2,38mm x 22,23mm I.D.]	2
37	Spring	2
38	Relief Valve Assembly, 5000 P.S.I. [345 bar]	2
39	Plug Assembly	1
39A	Tow Valve Assembly	1

Item No.	Description	Qty
+ 40	Retaining Ring	1
41	Separator Plug	1
+ 42	O-ring, 3/32 in. x 3/4 in. I.D. [2,38mm x 19,05mm I.D.]	1
43	Spreader	1
+ 44	O-ring, 1/16 in. x 3/8 in. I.D. [1,59mm x 9,53mm I.D.]	1
45	Coupler	1
46	Lock Ring	1
47	Inner Gerotor	1
48	Key	1
49	Outer Gerotor Ring	1
+ 51	O-ring, Molded	1
+ 51A	O-ring, Molded	1
52	Adaptor Assembly	1
53	Check Valve Assembly	2
+ 54	Back-up Washer	2
+ 55	O-ring, 1/16 in. x 7/16 in. I.D. [1,59mm x 11,11mm I.D.]	2
56	Steel Ball	2
57	Pin	2
58	Poppet Filter Relief	1
59	Spring	1
60	Spring Retainer	1
61	Plug Assembly	1
+ 62	O-ring, 3/32 in. x 41/64 in. I.D. [2,38mm x 16,27mm I.D.]	1
63	Mounting Support Bracket	1
+ 64	O-ring, 1/16 in. x 3-1/4 in. I.D. [1,59mm x 82,55mm I.D.]	1
65	Cover Plate	1
66	Cap Screw	2
67	Cover Plate Kit	1
S	Seal Repair Kit (70442-932)	1

### Tools Required for Disassembly and Reassembly

- 9/16 in. Socket
- 1 in. Socket
- 1 1/8 in. Socket
- Ratchet Wrench
- Torque Wrench (100 lb-ft)
- 7/16 in. Hex Key(Allen)
- 9/16 End Wrench
- Soft Face Hammer
- Internal Retaining Pliers (straight .090 Tip)
- External Retaining Pliers (straight .070 Tip)
- Regular or Locking Pliers
- Seal Diver or Similar Tool
- Petroleum Jelly (Such as Vaseline)

---

## Repair Information - Model 70442

Cleanliness is extremely important when repairing these pumps. Work in a clean area. Before disconnecting the lines, clean port area of pump. Disconnect hydraulic lines. Remove pump assembly from vehicle and plug ports. Thoroughly clean the outside of pump. After cleaning, remove port plugs and drain oil.

### Disassembly

- 1 Clamp the end of the drive shaft in a protected jaw vise with the body of the pump up and remove the four cap screws (34) from the pump assembly.
- 2 Use a plastic mallet and tap the adapter assembly (52) to loosen it, then pull the adapter straight up until it is free.
- 3 Remove retainer (60), spring (59), and poppet (58) from adapter assembly.
- 4 Remove the two check valve assemblies (53) from backplate (33). Pin (57) is a loose fit. Caution must be taken when removing check valve assembly so that pin (57) and ball (56) are not lost.
- 5 Remove outergerotor (49), inner gerotor (47), and key (48) from backplate (33). From front pump of tandem remove coupler (45) and lock ring (46).
- 6 Use screw driver slots in housing and pry up on backplate (33) or tap with plastic mallet to loosen, then pull the backplate straight up to remove. Remove gasket (31).
- 7 Remove tow valve assembly (39A) or plug (39) from backplate. Remove retaining ring (40) from spreader (43), and pull spreader from spreader plug (41).
- 8 Remove plug assembly (35), spring (37), and relief valve assembly (38).
- 9 Remove pump from vise and remove rotating assembly (29) from pump housing.
- 10 If pistons (20) did not come with piston block, you may remove them, spider (21), and spider pivot (22). See Figure 1
- 11 The disassembly of the piston block assembly (23) is not required unless the pins (25) or spring (27) are possibly damaged. See Figure 1

### Caution

The following procedure should be used if the spring is to be removed from the piston block. The spring (27) is highly compressed and the retaining ring (28) should not be removed without compressing the spring (27).

The following parts will be needed to disassemble the piston block:

- 2 ea. 3/8 in. I.D. x 1-1/8 in. O.D. flat washers [9,5mm I.D. x 28,6mm O.D.]
- 1 ea. 3/8 in. x 3-1/4 in. N.C. cap screw, and [9,5mm x 82,6mm N.C.]
- 1 ea. 5/16 in. N.C. nut [7.9mm]

Place one of the flat washers over the 3/8 X 3-1/4 cap screw and place this through the center of the piston block. Place the other washer over the cap screw and let it rest on the three pins. Screw the nut on and compress the spring inside the piston block. Use a pair of retaining ring pliers and remove the internal retaining ring. Remove the nut, bolt, and the two washers. Remove the washer (26), spring (27), washer (26), and three pins (25), and the pin keeper (24).

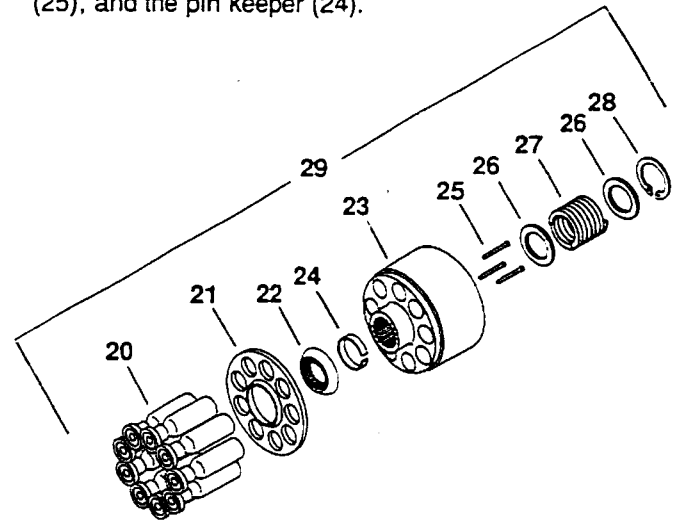

Figure 1

- 12 Remove retaining ring (1) from housing. Press shaft (8) from housing (9) and remove shaft seal (2), and washer (3).
- 13 Remove retaining ring (4) from shaft and remove thrust washers (5) and thrust bearing (6).
- 14 To remove the camplate (19) from the housing, remove the two retaining rings (14) from the sides of the housing. Remove the two covers (13 and 13A) and o-ring (12). Now remove the inner race (11) and needle bearings (10). The camplate can be slid over to one side and removed. The two camplate pivot bearings are loose fit into the housing; Do not be concerned if they are not tight.

15 Replace the shaft seal, gasket, backup washers and all o-rings with new items upon reassembly.

## Inspection

1 Inspect the charge pump relief valve seat inside the charge pump adapter. Check to insure that the seat is smooth and free of burrs or other defects.

2 Inspect the charge pump relief valve spring (59).

3 Inspect the gerotor pocket inside the charge pump adapter housing (52). It should not be scored excessively.

4 Inspect the needle bearing inside the charge pump adapter housing, making sure that needles remain in the bearing cage.

5 Inspect the check valve assembly (53), make sure the ball seat is in good condition and the ball is free to move.

6 Inspect the flat surface of the backplate (33), the finish on the gerotor side should show no galling. The finish on the piston block side should be smooth and free of grooves. Replace the backplate if it shows any of the wear characteristics outlined above. Insure that the cam stop is tight in the specific backplate (33) design.

7 Inspect the piston block (23). Insure the surface that contacts the backplate is smooth and free of grooves.

8 The pistons (20) should move freely in the piston block bore. If they are sticky in the bore, examine the bore for scoring or contamination.

9 Examine the O.D. of the pistons for finish condition. They should not show wear or deep scratches. Inspect the shoes for a snug fit on the ball end of the pistons and a flat smooth surface that comes in contact with the camplate. **DO NOT LAP PISTON SHOES.**

10 Examine the spider (21) for wear in the pivot area.

11 Examine the pivot (22) to insure smoothness and no signs of wear.

12 The finish on polished shoe surface of the camplate (19) should show no signs of scoring.

13 Inspect the shaft (8) for fretting in the bearing and spline areas.

14 Inspect thrust bearing (6) and washers (5) for wear.

15 Inspect the needle bearings in the housing assembly, making sure needles remain in bearing cage.

## Reassembly

1 Clean all parts in suitable solvent. lubricate all critical moving parts before reassembly.

2 Place the camplate (19) into the housing with the long trunnion down and to the appropriate side of linkage on the machine.

3 After installing the camplate, install new o-ring (18) on camplate trunnion. Insert the needle bearings (10) and the bearing inner race (11) over the shaft and slide into the housing. The numbered end of the race and bearing should face outward and the chamfered I.D. of the race inward. Install new o-ring (12) around O.D. of trunnion bearings. Install trunnion cover (13A) and sleeve cover (13) and secure with retaining ring (14).

4 Install retaining ring (4) on shaft (8). Install thrust washer (5), thrust bearing (6), and second thrust washer (5). Secure with second retaining ring (4).

5 Install shaft in housing. Install washer (3), new shaft seal (2), and retain with retaining ring (1).

6 If piston block assembly was disassembled complete the following: Compress the pin keeper (24) and install in the spline of piston block. Install the three pins (25) with head end to the inside of the block and install in the special grooves of the piston block spline.

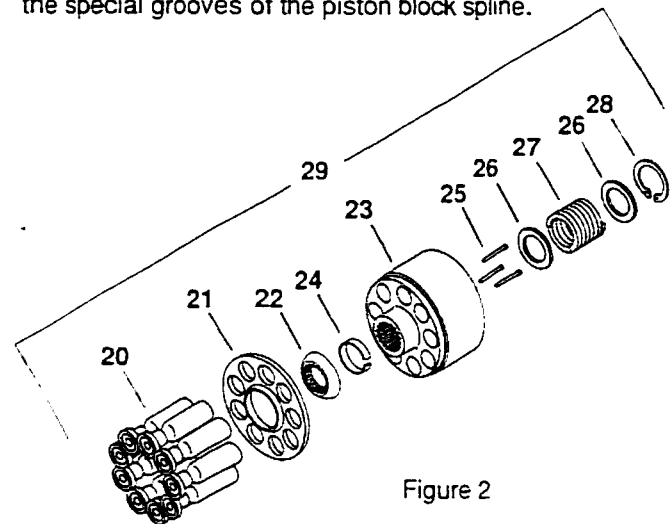

Figure 2

7 Install the washer (26), spring (27), and second washer (26) in the piston block. Use the two 3/8 I.D. washers, nut, and the 3/8 x 3-1/4 cap screw to compress the spring and retain with retaining ring (28). Remove the nut, cap screw and the two washers.

8 Install the pivot (22), spider (21), and the piston assemblies (20) on the piston block assembly (23). Install rotating assembly (29) into housing assembly over shaft. The piston shoes must make contact with the camplate. Be sure all parts are in their proper position before proceeding.

- 9 Clamp pump assembly in a protected jaw vise with the open end of the housing up.
- 10 Install new gasket (31) over roll pins in housing.
- 11 Place backplate (33) over shaft and on housing with gasket in place.
- 12 Place ball (56) into check valve housing and secure with pin (57). Install new o-ring (55) and back-up washer (54) on check valve assembly (53). O-ring is nearest pin in check valve. Check valve is installed with the pin end into backplate.
- 13 Install outer gerotor ring (49) into adapter assembly (52). Lubricate ring to hold in place.
- 14 Install key (48) and inner gerotor (47) onto shaft (8) into backplate (33). Lubricate inner gerotor.
- 15 Install new o-ring (51 or 51A) in groove, hold in place with clean clear grease. Place adapter plate assembly (52) on pump backplate. Install four cap screws (34 & 34A) and torque 27 to 31 lbs. ft. [37 to 42 N·m] (If bracket (63) is used, cap screws (34B) are used.)
- 16 Install new o-rings (42 & 44). Insert spreader (43) into separator plug (41) and retain with retaining ring (40).
- 17 Install tow valve assembly (38) or plug (39) in backplate (33). Torque 27 to 30 lbs. ft. [37 to 40 N·m].
- 18 Install relief valve assembly (38) and spring (37) into backplate. Place new o-ring (36) on plug (35) and retain spring and relief valve. Torque plug (35) 95-105 lbs ft. [129 to 142 N·m].
- 19 Remove pump from vise and install poppet (58), spring (59), and spring retainer (60) Torque spring retainer (60) 5 to 7 lbs ft. [7 to 10 N·m].

## Start-up Procedure

When initially starting a new or a rebuilt propulsion system, it is extremely important that the start-up procedure be followed. It prevents the chance of damaging the unit which might occur if the system was not properly purged with oil before start-up.

- 1 After the propulsion components have been properly installed, fill the pump housing at least half full with filtered system oil. Connect all hydraulic lines and check to be sure they are tight.
- 2 Install and adjust all control linkage.
- 3 Fill the reservoir with an approved oil that has been filtered through a 10 micron filter.
- 4 Gasoline or L.P. engines: remove the coil wire and turn the engine over for 15 seconds. Diesel engines: shut off the fuel flow to the injector and turn the engine over for 15 seconds.
- 5 Replace the coil wire or return the fuel flow to the injectors. Place the propulsion unit in the neutral position, start the engine and run it at a low idle. The charge pump should immediately pick up oil and fill the system. If there is no indication of fill in 30 seconds, stop engine and determine the cause.
- 6 After the system starts to show signs of fill, slowly move pump camplate to a slight cam angle. Continue to operate system slowly with no load on motors until system responds fully.
- 7 Check fluid level in the reservoir and refill if necessary to the proper level with an approved filtered oil.
- 8 Check all line connections for leaks and tighten if necessary.
- 9 The machine is now ready to be put into operation.
- 10 Short hour filter changes are recommended for the first two changes after placing the machine back into operation. The first filter would be changed in 3-5 hours and the second at approximately 50 hours. Routine scheduled filter changes are recommended for maximum life of the hydraulic system.

---

---



## Trouble Shooting

Problem	Possible Causes	Correction
<p><b>1</b> System will not operate in either direction.</p>	<p><b>A</b> Oil supply low.  <b>B</b> Oil filter clogged.  <b>C</b> Oil too heavy.  <b>D</b> Control linkage misadjusted.</p> <p><b>E</b> Low charge pressure.</p> <p><b>F</b> Charge pump key sheared.  <b>G</b> Charge pump relief valve damaged.  <b>H</b> Charge pump gears worn or scored.</p> <p><b>I</b> Internal charge pump damage.</p> <p><b>J</b> Drive coupling broken.</p> <p><b>L</b> Relief valve stuck open.</p> <p><b>M</b> Damaged check valve.</p>	<p><b>A</b> Check oil level, fill.  <b>B</b> Replace filter element.  <b>C</b> Use proper viscosity oil.  <b>D</b> Check to see if control linkage is binding or unfastened.  <b>E</b> See below: F, G, H, &amp; I. Pressure should be 60-100 P.S.I.  <b>F</b> Inspect charge pump for damage.  <b>G</b> Remove relief valve parts, examine parts and seat. Replace necessary parts.  <b>H</b> Remove parts and examine. Replace defective parts. If severe scoring is indicated, remove complete pump disassemble, clean, and inspect for damage.  <b>I</b> Disassemble pump, inspect for damage.  <b>J</b> Inspect coupling for sheared spline, key or broken chain.  <b>L</b> Remove relief valve, clean or replace.  <b>M</b> Disassemble and check if check valve is faulty or damaged.</p>
<p><b>2</b> System Noisy</p>	<p><b>A</b> Air in system.  <b>B</b> Loose suction line.  <b>C</b> Clogged suction filter.  <b>D</b> Internal pump or motor damage.</p>	<p><b>A</b> Low oil level in reservoir.  <b>B</b> Tighten fittings.  <b>C</b> Replace filter element.  <b>D</b> Disassemble, inspect and repair.</p>
<p><b>3</b> Sluggish response to acceleration or deceleration.</p>	<p><b>A</b> Air in system.  <b>B</b> Low charge pressure.  <b>C</b> Internal pump or motor wear or damage.  <b>D</b> Relief valve dirty or damaged.</p>	<p><b>A</b> See step 1-A, 1-B, 1-C, 2-B.  <b>B</b> See step 1-F 1-6, 1-I.  <b>C</b> Disassemble, inspect and repair.  <b>D</b> Remove, clean or replace.</p>

# Identification Numbers

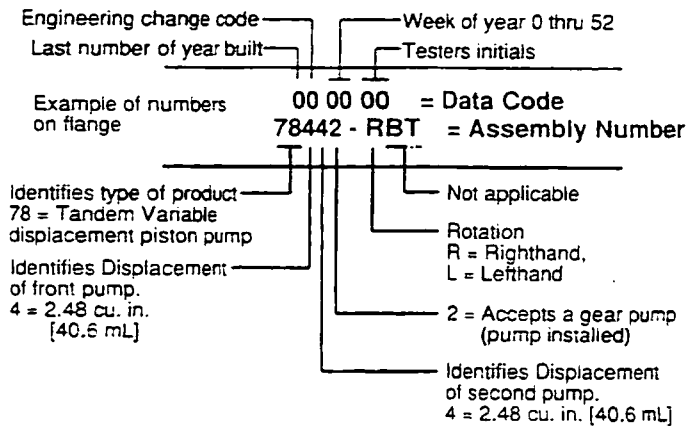
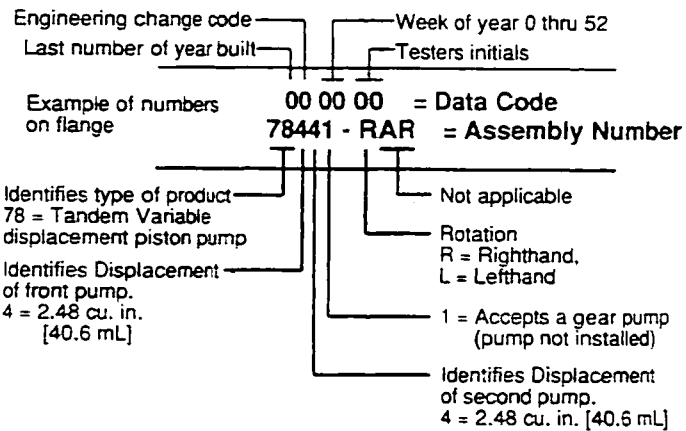
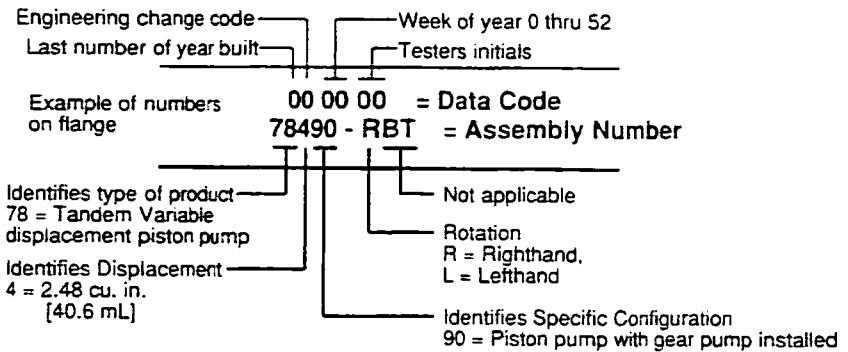
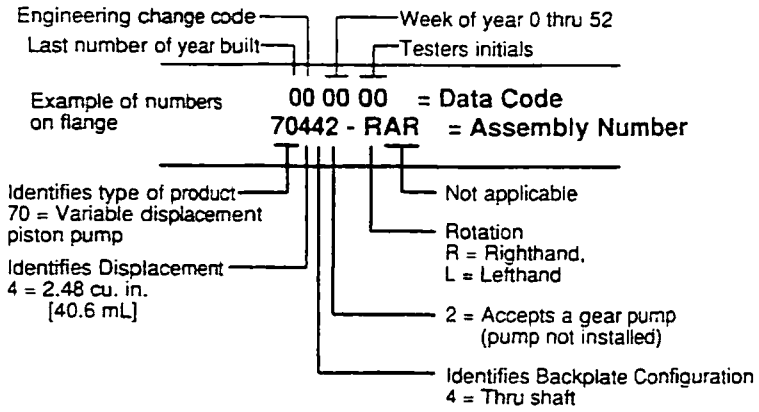

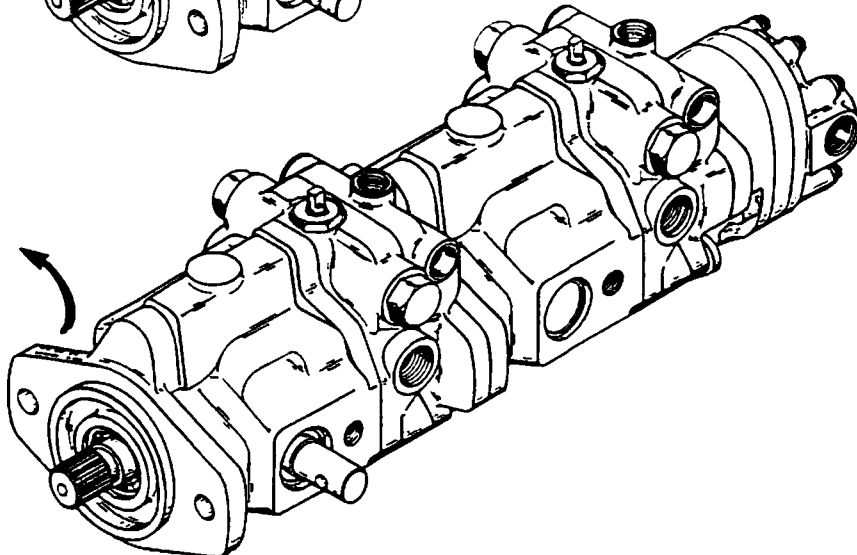
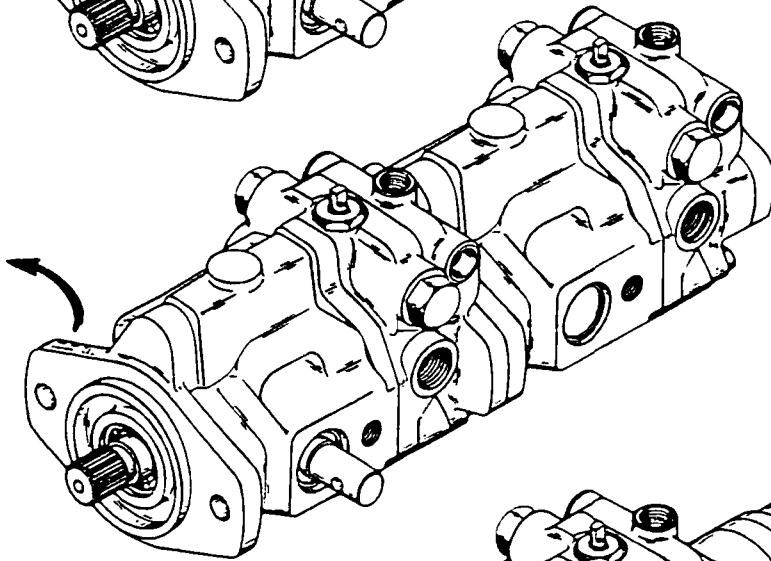
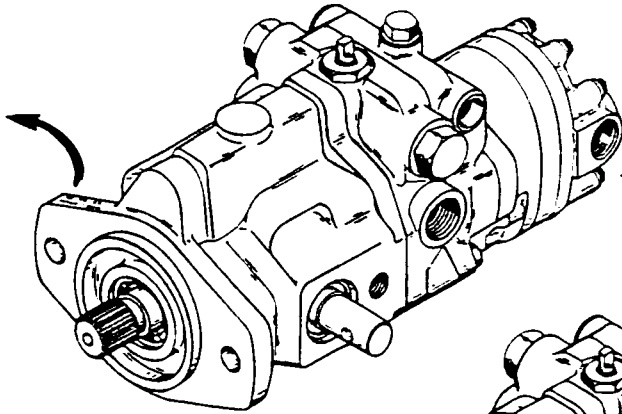
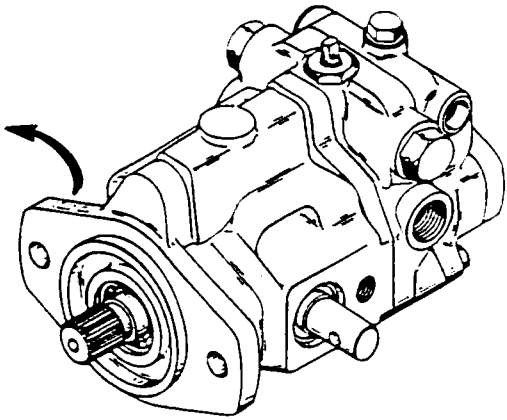

**In ordering spare parts include the following information:**

- 1 Product Number
- 2 Date Code
- 3 Part Name
- 4 Part Number
- 5 Quantity of Parts

---

Eaton  
14615 Lone Oak Road  
Eden Prairie, MN 55344  
USA  
Tel: 952 937-9800  
Fax: 952 974-7722  
[www.hydraulics.eaton.com](http://www.hydraulics.eaton.com)

Eaton  
20 Rosamond Road  
Footscray  
Victoria 3011  
Australia  
Tel: (61) 3 9319 8222  
Fax: (61) 3 9318 5714

Eaton  
Dr.-Reckeweg-Str. 1  
D-76532 Baden-Baden  
Germany  
Tel: (49) 7221 682-0  
Fax: (49) 7221 682-788

**EAT•N**

**Hydraulics**

© 2002 Eaton Corporation  
All rights reserved  
Printed in USA  
Document No. 07-619  
August 2002