

EAT•N

Hydraulics

39055-DAQ Self-Level Valve

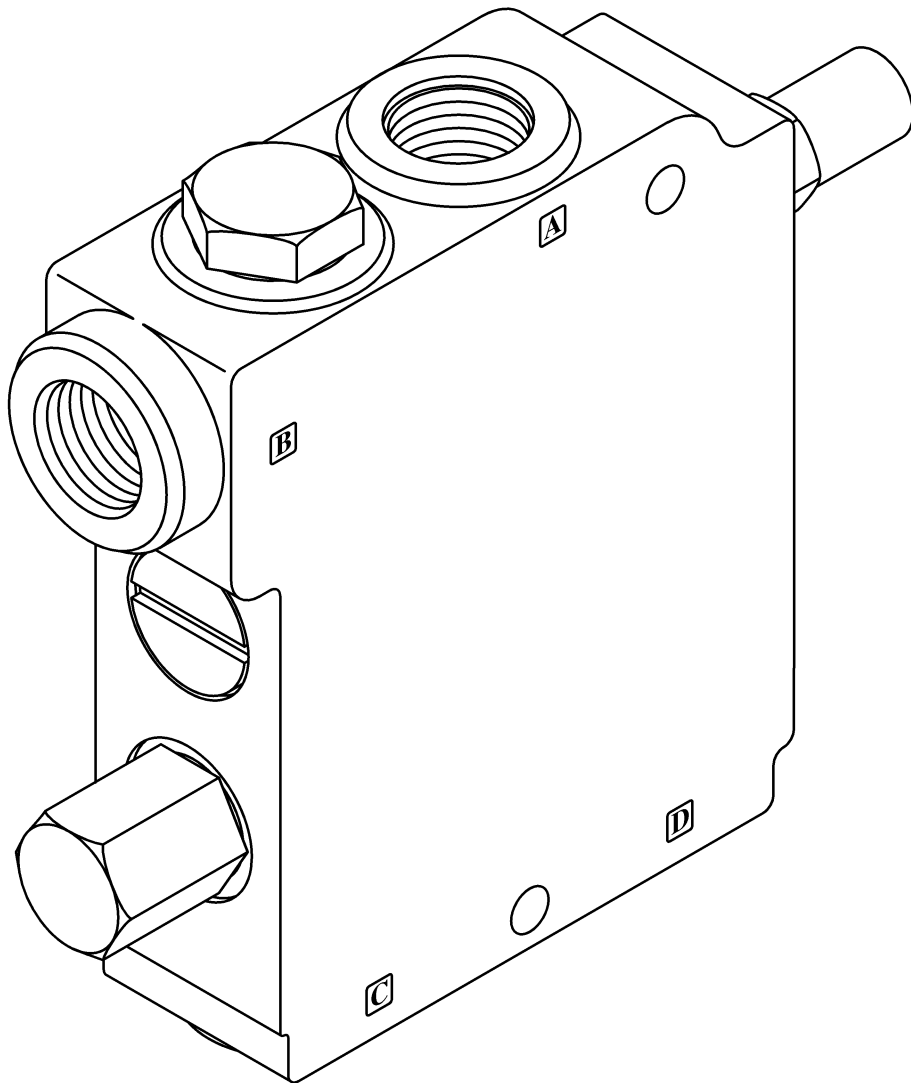

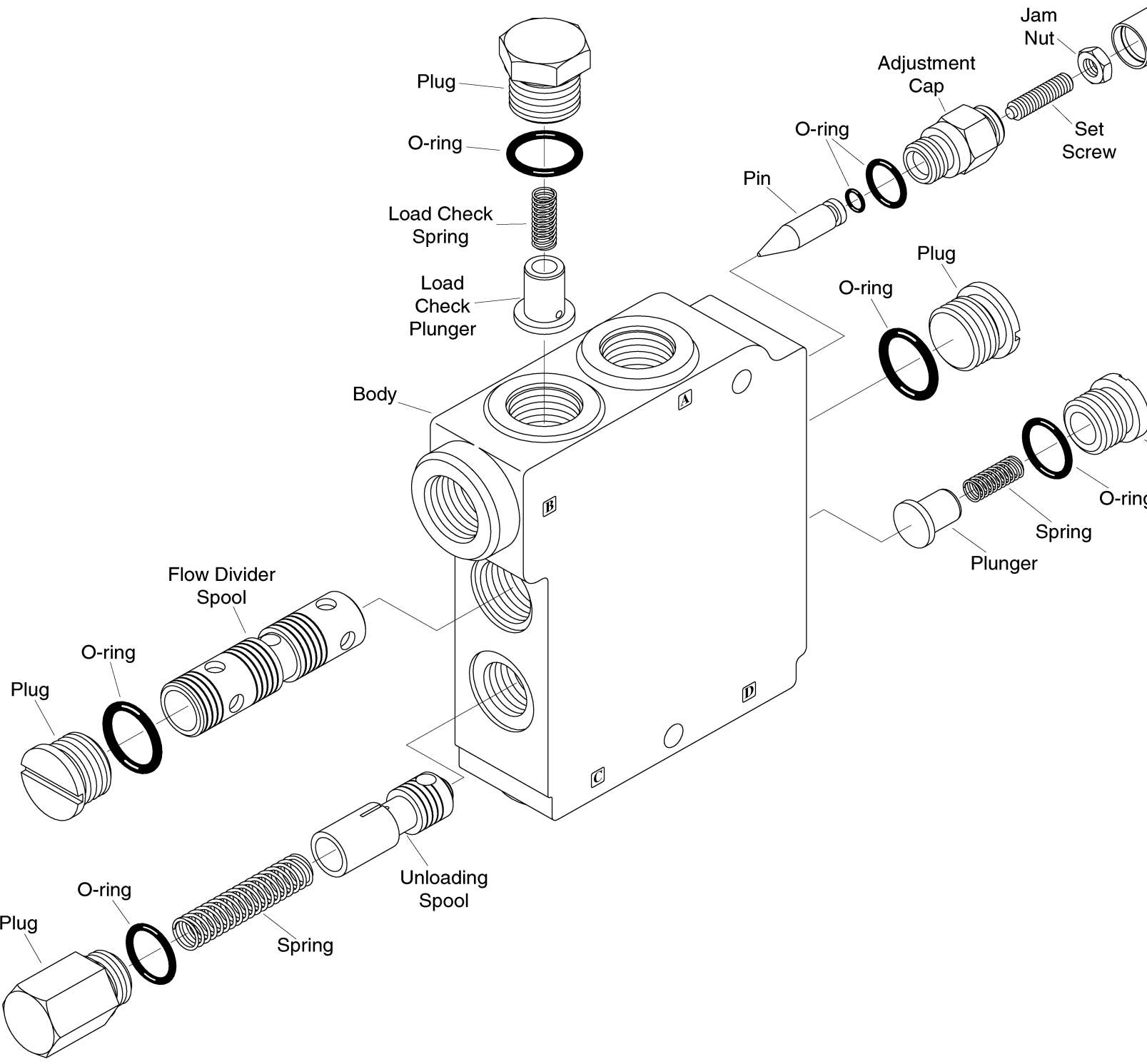

Disassembly

Cleanliness is extremely important when repairing hydraulic valves. Work in a clean area. Before disconnecting the hydraulic lines, clean the valve's port area. Before disassembly, plug all ports and thoroughly clean the exterior of the valve.

- 1 Disassemble the self-level valve as shown in the parts drawing on the previous page.
- 2 Discard all used o-rings.

Inspection

- 3 Remove all nicks and burrs from parts with fine emery cloth.
- 4 Thoroughly clean and dry all parts.
- 5 Inspect the valve body spool bores for scoring and contamination.
- 6 Inspect the flow divider and unloading spools for scratches; they should be smooth and free of nicks and burrs. Spools should slide freely inside body bores. Inspect the dampening orifice in the unloading spool, make sure that it is free of contamination.
- 7 Inspect the plunger seats, in the valve body, and plungers for excessive wear, burrs, or roughness.
- 8 Inspect the tapered portion of the pin for damage.
- 9 Inspect the springs for damage or excessive wear.

Reassembly

- 10 Install new o-rings on all plugs.
- 11 Lubricate all parts with clean hydraulic fluid.
- 12 Install the unloading spool, spring, and plug.
- 13 Install the flow divider spool, make sure the internal orifice is towards port B. Install the plugs.
- 14 Install the plungers, springs, and plugs.
- 15 Install a new o-ring on the pin and slide the pin into the adjustment cap.
- 16 Install a new o-ring on the adjustment cap and install it in the valve body.
- 17 Install the set screw and jam nut; do not tighten.
- 18 Install the self-level valve on the machine. Plumb as follows:
 - Port A – boom cylinder rod port – boom lower
 - Port B – control valve – boom lower
 - Port C – bucket cylinder rod port and tied to control valve – bucket curl
 - Port D – bucket cylinder head port and tied to control valve – bucket dump

Adjust the set screw until the desired flow split from ports B and D is achieved. The standard flow split setting is 60% from port D and 40% from port B. When the desired flow split is reached, tighten the jam nut and install the cover.

Troubleshooting		
Trouble	Probable Cause	Remedy
1. Boom delay at start of self-level or unstable self-level.	A. Air in system.	A. Cycle boom and bucket slowly to rid system of air.
2. Loaded bucket dumps or uncurls when control valve is in neutral.	A. Unloading spool is leaking.	A. Remove and inspect unloading spool for damage.
3. Insufficient self-level.	A. Pin is out of adjustment. B. Broken unloading spool spring. C. Flow divider spool stuck towards adjustment pin side.	A. Re-adjust pin to achieve proper flow split. B. Replace unloading spool spring. C. Remove flow divider spool and check for damage.
4. Bucket dumps faster than boom raises. Too much self-level.	A. Pin is out of adjustment. B. Flow divider spool is stuck towards port B. C. Flow divider spool installed wrong.	A. Re-adjust pin to achieve proper flow split. B. Remove flow divider spool and inspect for damage. C. Remove spool and install with internal orifice towards port B.
5. With bucket dumped, boom is slow in starting to raise.	A. Dampening orifice in the unloading spool is plugged.	A. Remove unloading spool and clean dampening orifice.
6. Bucket does not move in self-level.	A. Pin is screwed in all the way. B. Dampening orifice in the unloading spool is plugged. C. Ports A and B plumbed backwards.	A. Re-adjust pin to achieve proper flow split. B. Remove unloading spool and clean dampening orifice. C. Reverse hoses to ports A and B.
7. Bucket Curls in self-level.	A. Ports C and D plumbed backwards.	A. Reverse hoses to ports C and D.
8. External leakage	A. Damaged o-ring.	A. Replace o-ring.

Eaton
14615 Lone Oak Road
Eden Prairie, MN 55344
USA
Tel: 952 937-9800
Fax: 952 974-7722
www.hydraulics.eaton.com

Eaton
20 Rosamond Road
Footscray
Victoria 3011
Australia
Tel: (61) 3 9319 8222
Fax: (61) 3 9318 5714

Eaton
46 New Lane, Havant
Hampshire PO9 2NB
England
Tel: (44) 23 92 486 451
Fax: (44) 23 92 487 110