

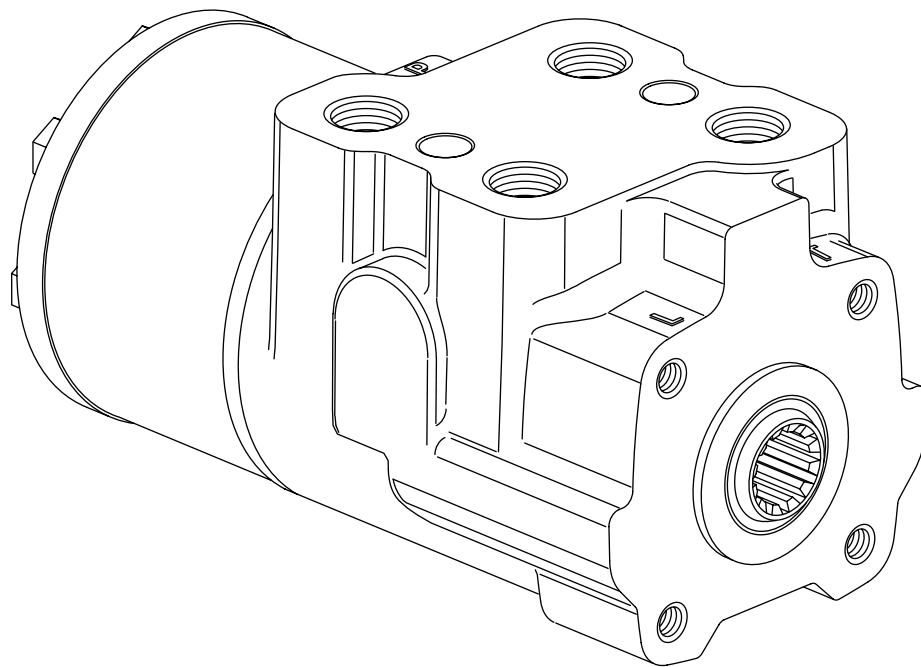

Repair Information



20 Series
Steering Control Unit

001

20 Series Steering Control Units

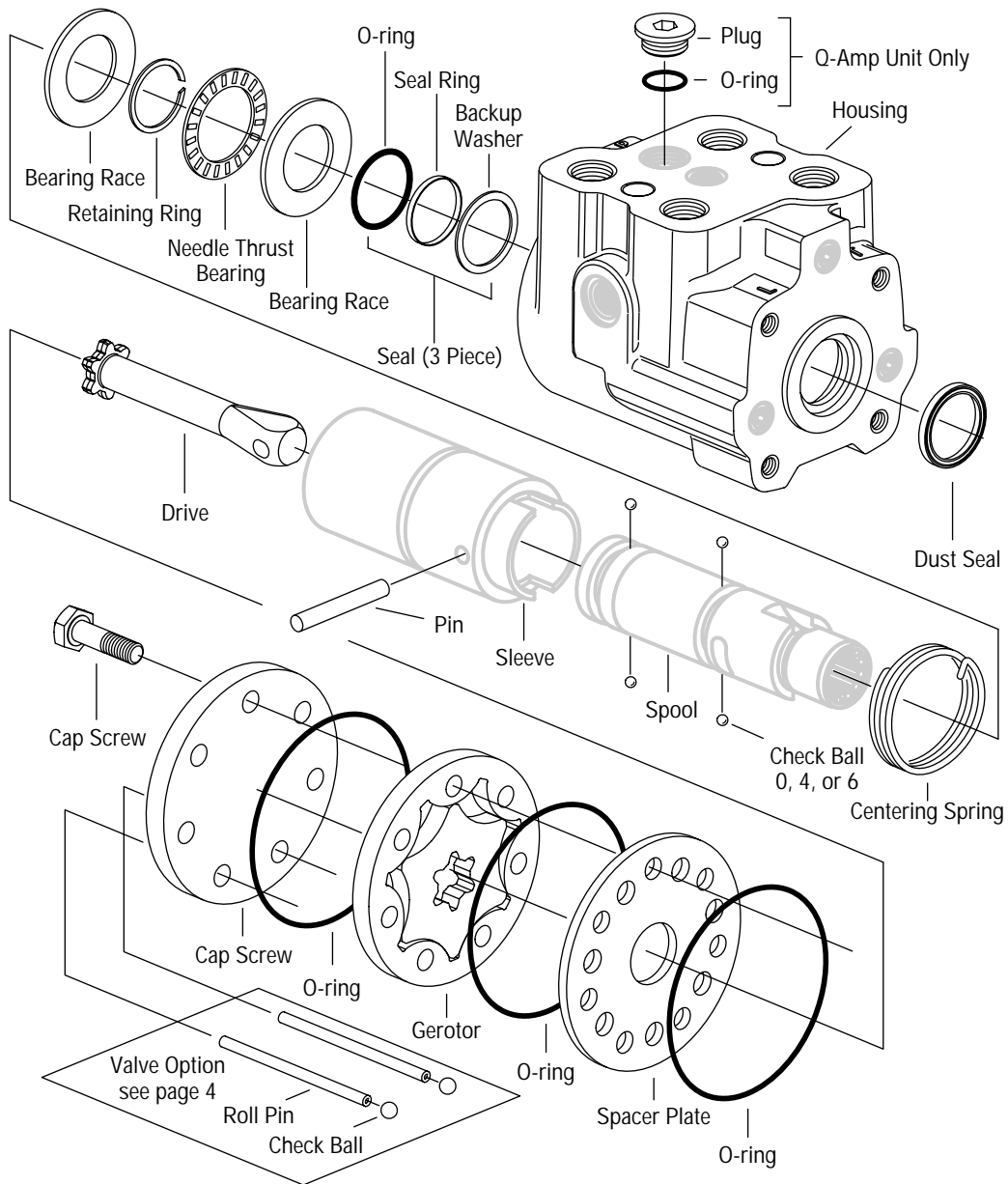

20 Series Steering Control Units

Tools Required

- 13 mm Socket
- 15/16 in. Hex Key
- Torque Wrench (40 Nm [350 lb-in] Capacity)
- Small Blade Screwdriver
- Soda Straws (2)
- Retaining Ring Pliers - Eaton Part No. 600610

Complete Tool Available from Eaton Corp. No. 600604.

Splined Shaft End No. 8063
Available from Eaton Corp.

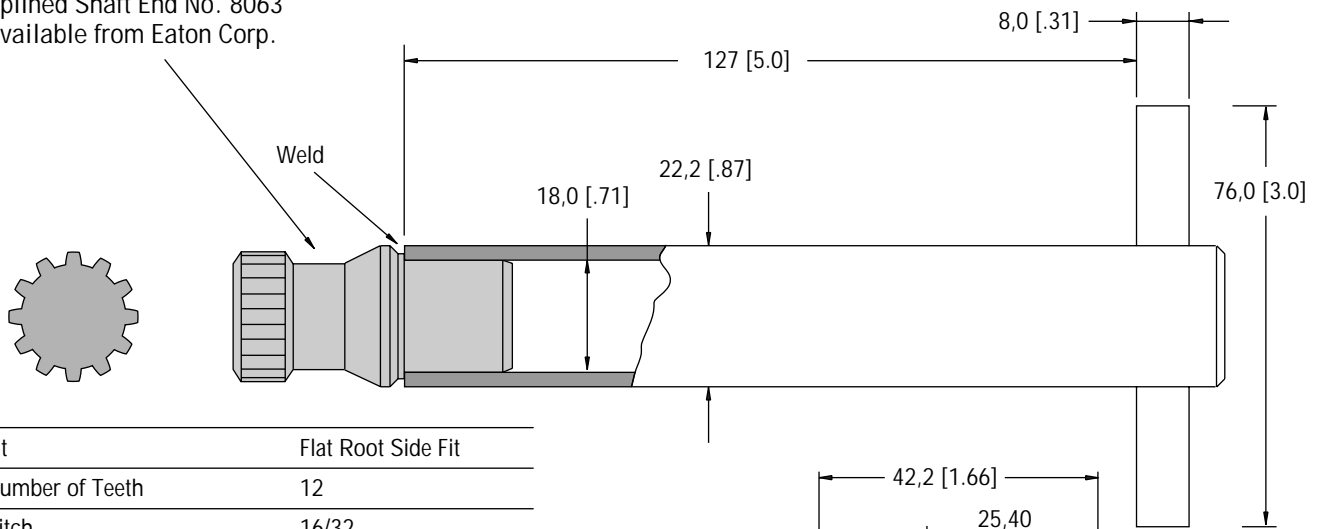

Fit	Flat Root Side Fit
Number of Teeth	12
Pitch	16/32
Pressure Angle	30°
Class of Fit	Special
Circular Tooth Thickness	
Max. Effective	2,428 [.0956]
Min. Actual	2,362 [.0930]

Splined End — AISI 8620 M'l Case
hardened to RC 40-50

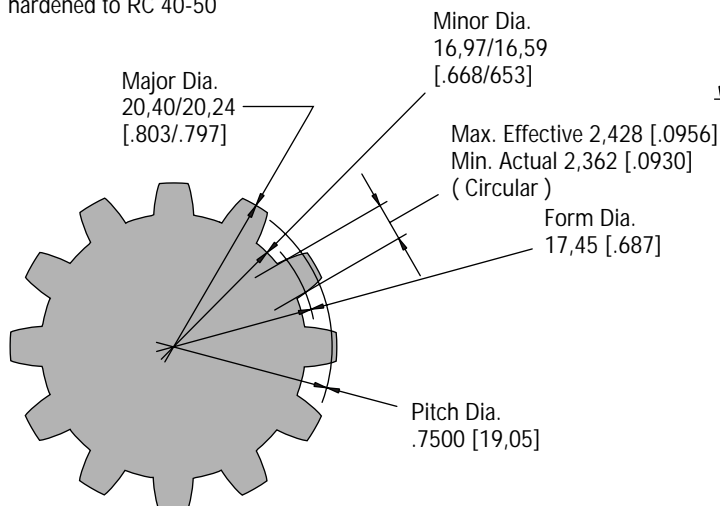
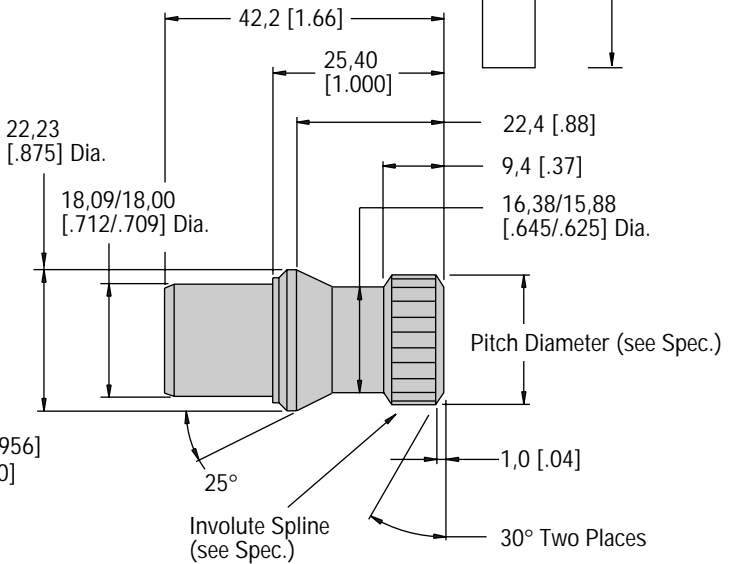

20 Series Steering Control Units

All housing valves are factory adjusted on assembled units to a code designation and are not to be changed. This housing (with specified valve pressure settings), the mating spool, and the sleeve are not practical replacement parts.

Port Combinations

Pressure Tank	Load Sensing Port (1) —
Left	Load Sensing Units Only
Right	
3/4 -16	7/16 - 20
G1/2 (BSP)	G1/4 (BSP)
M - 18	M - 12

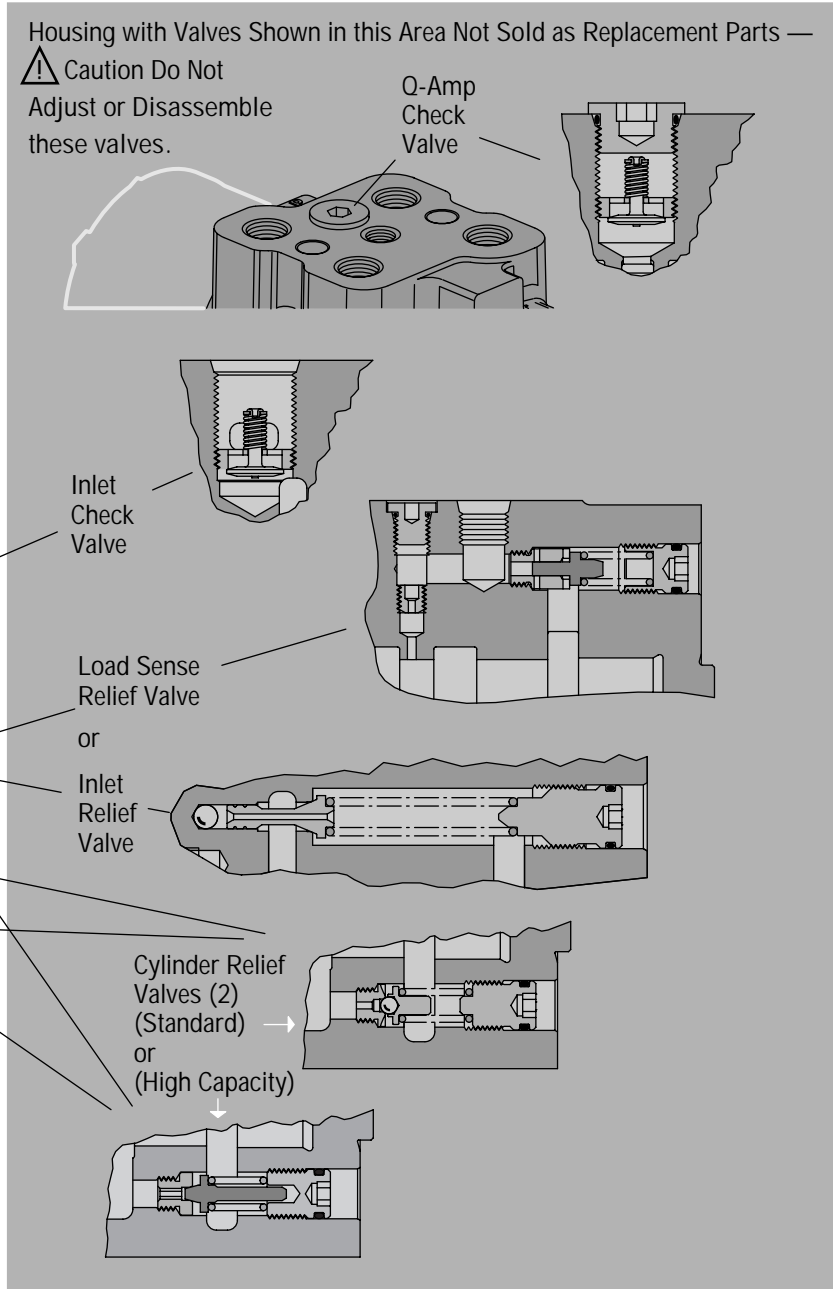
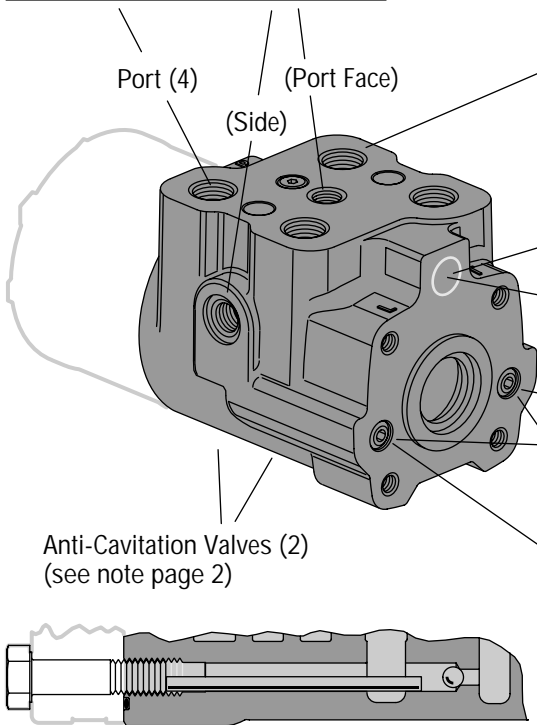

20 Series Steering Control Units

Disassembly

Cleanliness is extremely important when repairing a hydraulic Steering Control Unit (SCU). Work in a clean area. Before disconnecting the hydraulic lines, clean the port area of the SCU. Before disassembly, drain the oil, then plug the ports and thoroughly clean the exterior of the SCU. During repairs, always protect machined surfaces.

Note: Steering control units with anti-cavitation valves require special handling in both disassembly and reassembly. Ball valves (2) can end up in a cavity in the housing were they are not supposed to be. These unit must be disassembled and reassembled in the vertical position; removal of anti-cavitation valves is outlined in step 8.

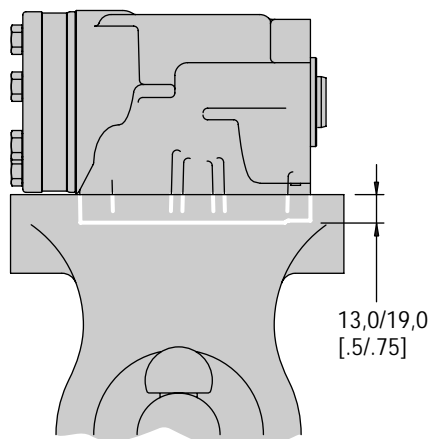

Mount steering control unit in vise horizontally for breaking loose seven cap screws. Use this mounting position for final torque of reassembled unit.

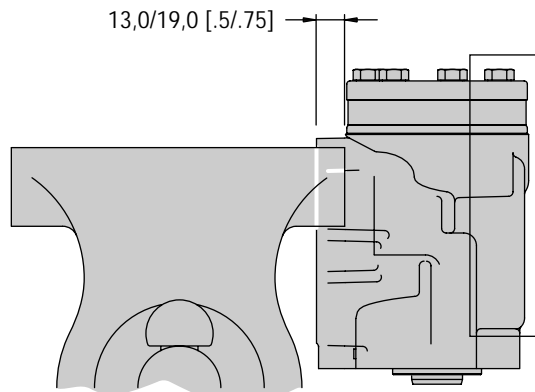

After cap screws have been loosened, mount steering control unit in the vise vertically for disassembly and reassembly. Note: Illustrations have been created from the exploded parts drawing, and do not relate the parts correctly as seen by the service person.

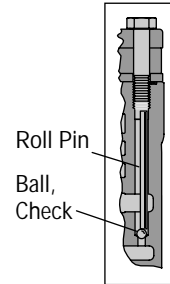

Anti-Cavitation Valves (located under these two cap screws)

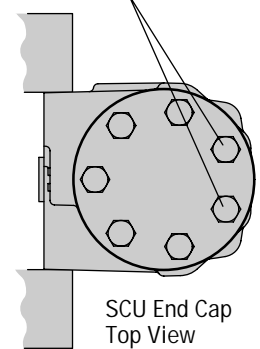

SCU End Cap Top View

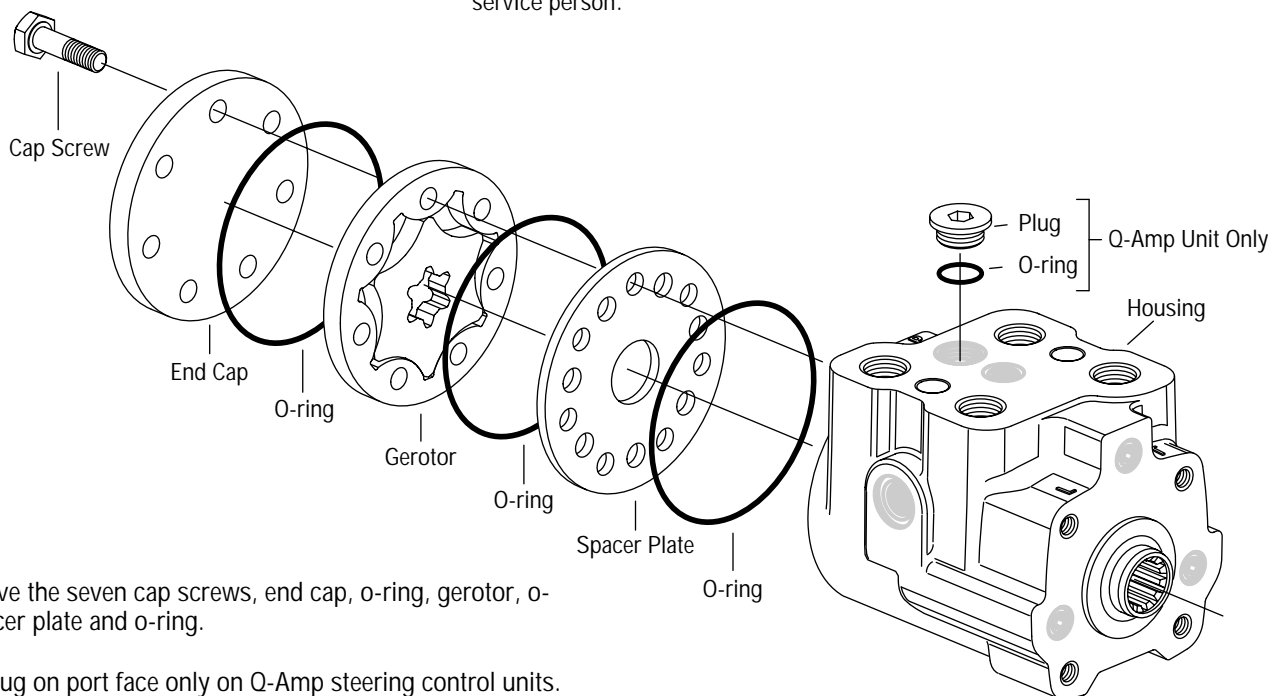

1 Remove the seven cap screws, end cap, o-ring, gerotor, o-ring spacer plate and o-ring.

Note: Plug on port face only on Q-Amp steering control units.

20 Series Steering Control Units

Disassembly

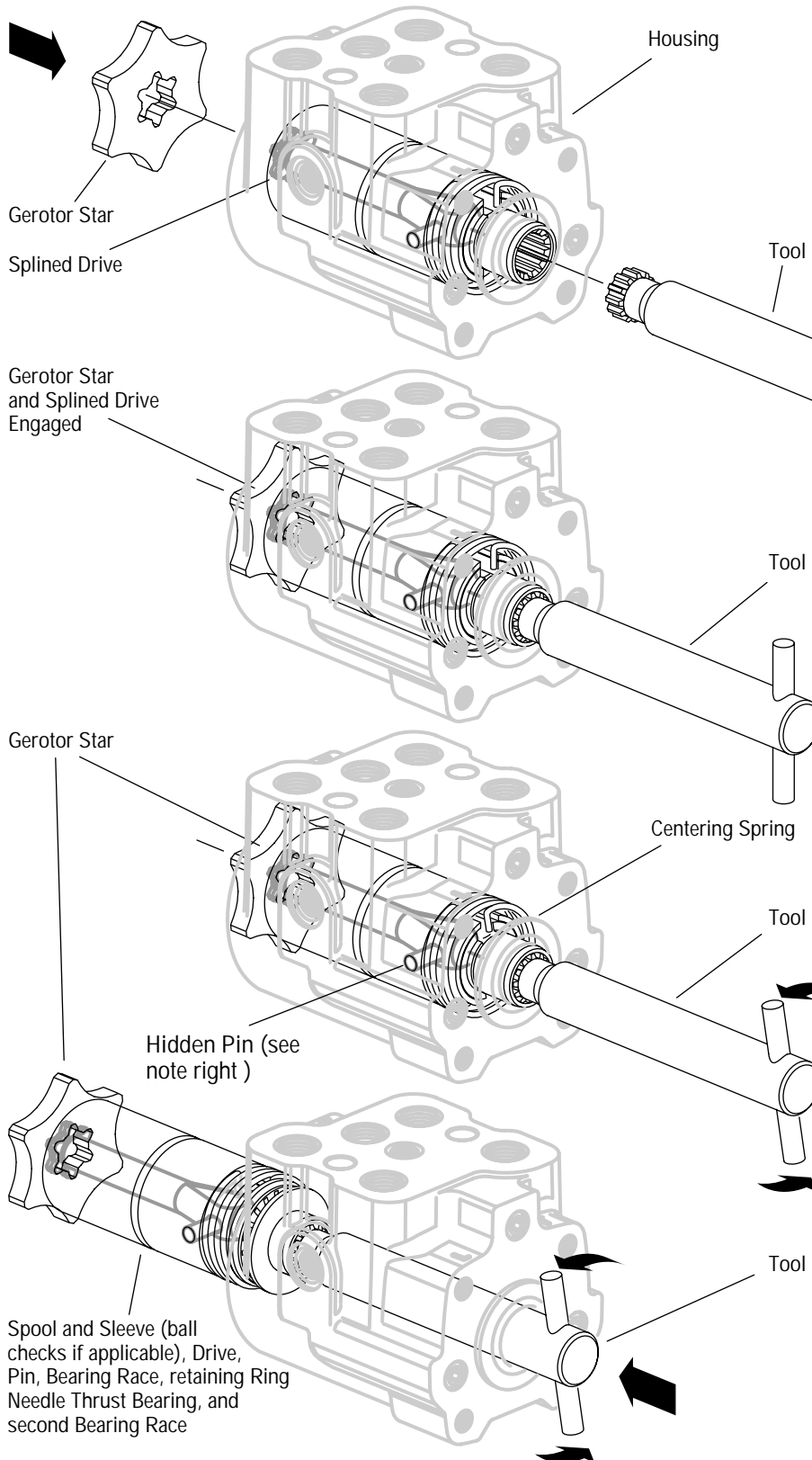

Note Hidden Pin. If tension on this pin is released before these parts are fully disengaged and the pin is not horizontal, the pin can drop and lockup can occur like a deadbolt. Positioning unit vertically is a safe option and is required if the unit has anti-cavitation valves.

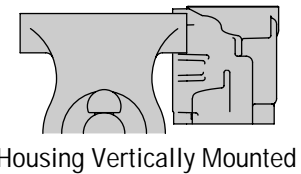

2 Engage tool with splined end of spool.

3 Protect gerotor star and hand with shop towel — hold gerotor star and splined drive from turning.

4 Twist tool to compress centering spring radially CW or CCW, decreasing the coil diameter of the centering spring allowing it to be removed along with the spool and sleeve (ball checks if applicable), drive, pin, bearing race (2), retaining ring, and needle thrust bearing. (Bearing races, retaining ring, and needle thrust bearing, not shown on drawing (left). Centering spring shown compressed.)

5 With drive held stationary and centering spring compressed, carefully push these assembled parts out of housing.

20 Series Steering Control Units Disassembly

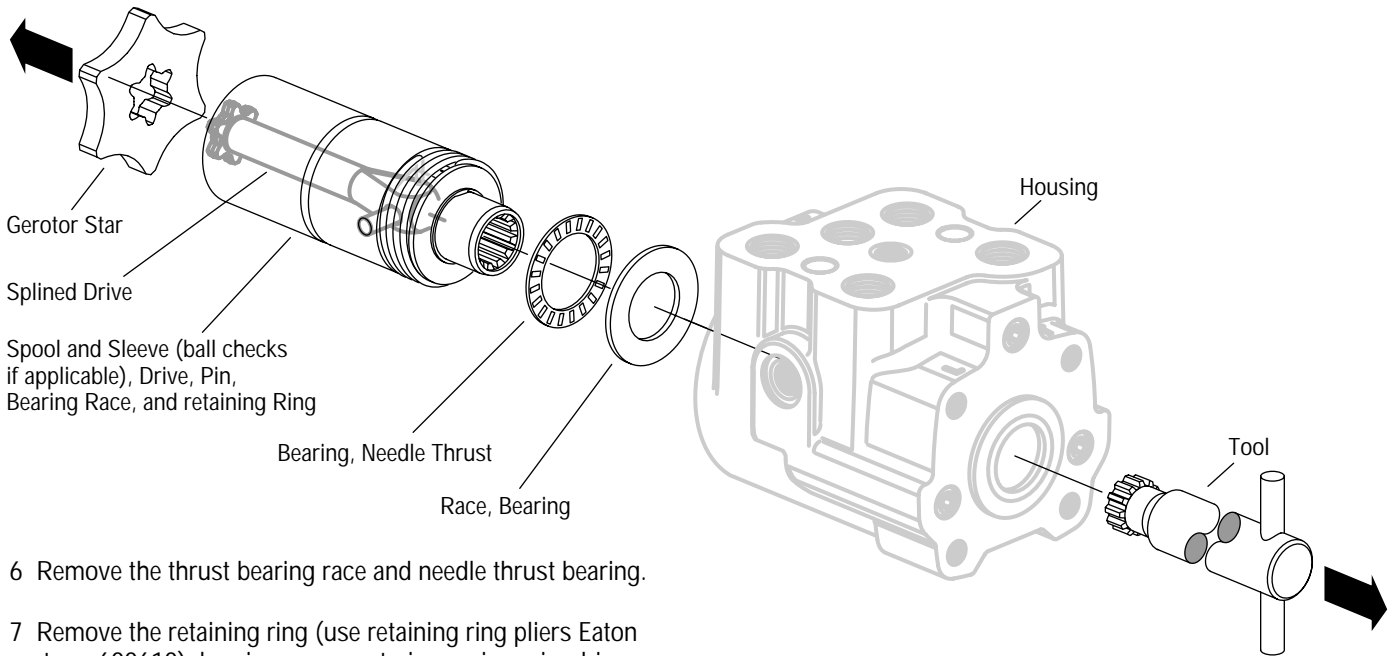

6 Remove the thrust bearing race and needle thrust bearing.

7 Remove the retaining ring (use retaining ring pliers Eaton part no. 600610), bearing race, centering spring, pin, drive, spool, sleeve, and ball checks if applicable.

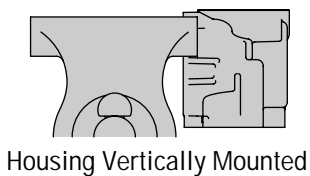
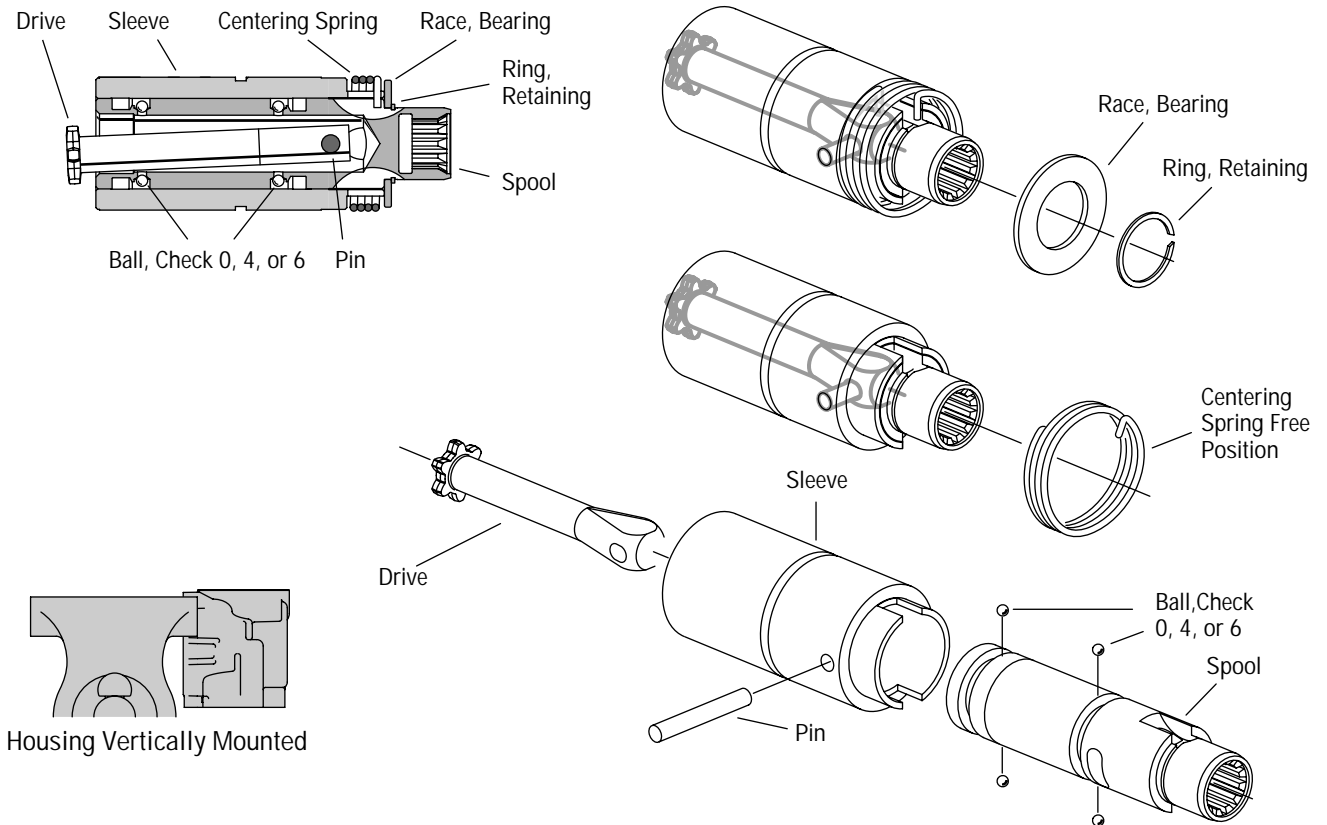

20 Series Steering Control Units

Disassembly

Optional Anti-Cavitation Valves

Disassembly

8 Insert two soda straws, one in each of two threaded holes, as a safety measure for removal of two small ball check valves and roll pins (correct threaded holes identified in illustration right). Remove housing from vise, tilt the housing and bring the port face upward. Continue turning the housing until the roll pins and ball checks slide through the straws from the meter (Gerotor) end of the housing.

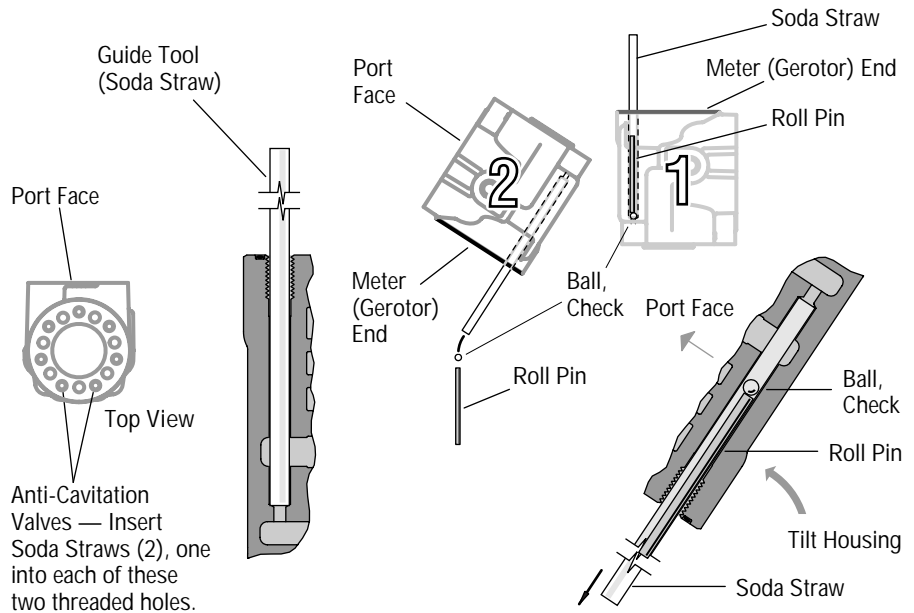

9 Remove the shaft seal. These three parts may or may not still be in the housing. These parts include o-ring, seal ring, and backup washer.

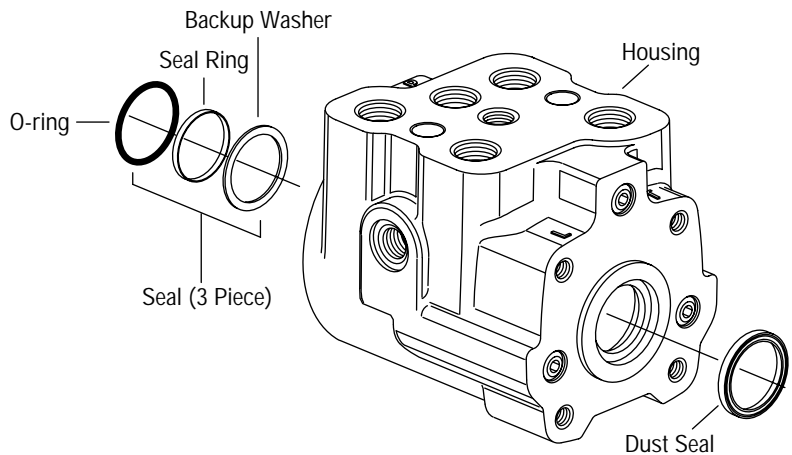

10 Using a small blade screwdriver, carefully pry the dust seal from the housing.

Important: Do not damage the dust seal seat.

Reassembly

Check all mating surfaces. Replace any parts that have scratches or burrs to lessen the chance of leakage. Wash all metal parts in clean solvent. Blow them dry with pressurized air. Do not wipe parts dry with paper towels or cloth as lint in a hydraulic system will cause damage.

Note: Always use new seals when reassembling hydraulic steering control units. Refer to parts list 6-326 for seal kit numbers, replacement parts, and ordering information.

Important: During reassembly lubricate the new seals with a petroleum jelly such as Vaseline®. Also lubricate machined surfaces with clean hydraulic fluid.

11 Lubricate and install the dust seal (see drawing (right) for correct seal orientation).

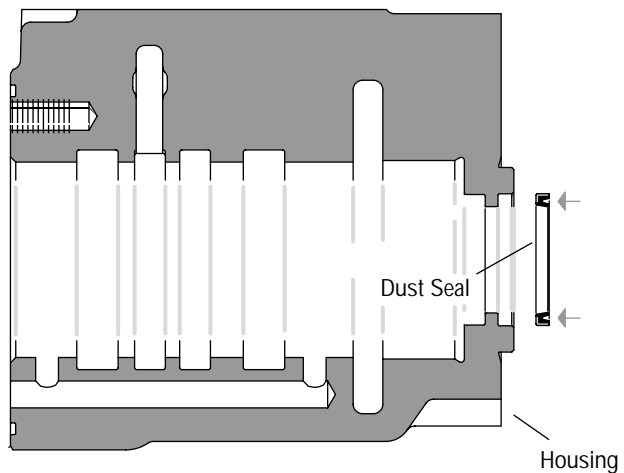

20 Series Steering Control Units

Reassembly

Optional Anti-Cavitation Valves

12 Installing the anti-cavitation ball checks seems simple enough. However, a word of caution: use a soda straw as a guide tool. Drop the straw into the hole to the bottom of bore, then drop ball through straw. Pull straw and use the same procedure in second ball seat. Check each bore with small light to make sure each ball is in the correct place. Add roll pin in each bore.

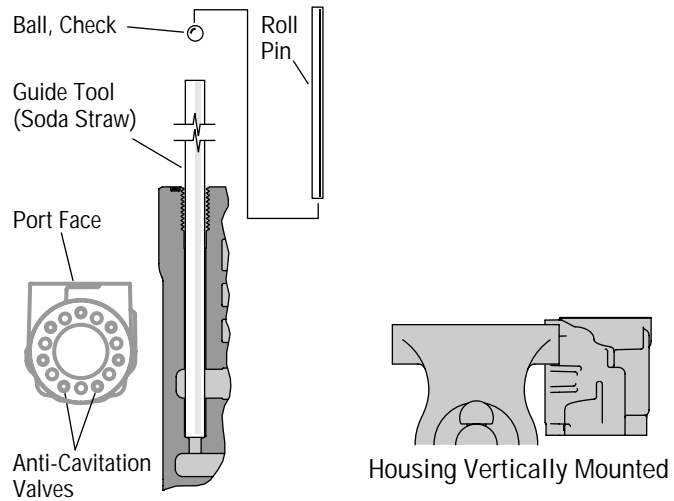

13 Apply a light coating of clean hydraulic fluid to the spool and slide it into the sleeve along with the ball checks if applicable.

14 Install the drive and pin.

15 Install the centering spring. Position one end of spring in slotted end of spool and sleeve, and compress the spring radially (CCW) to engage free end of spring.

16 Install the bearing race and retaining ring (use retaining ring pliers Eaton part no. 600610) onto spool.

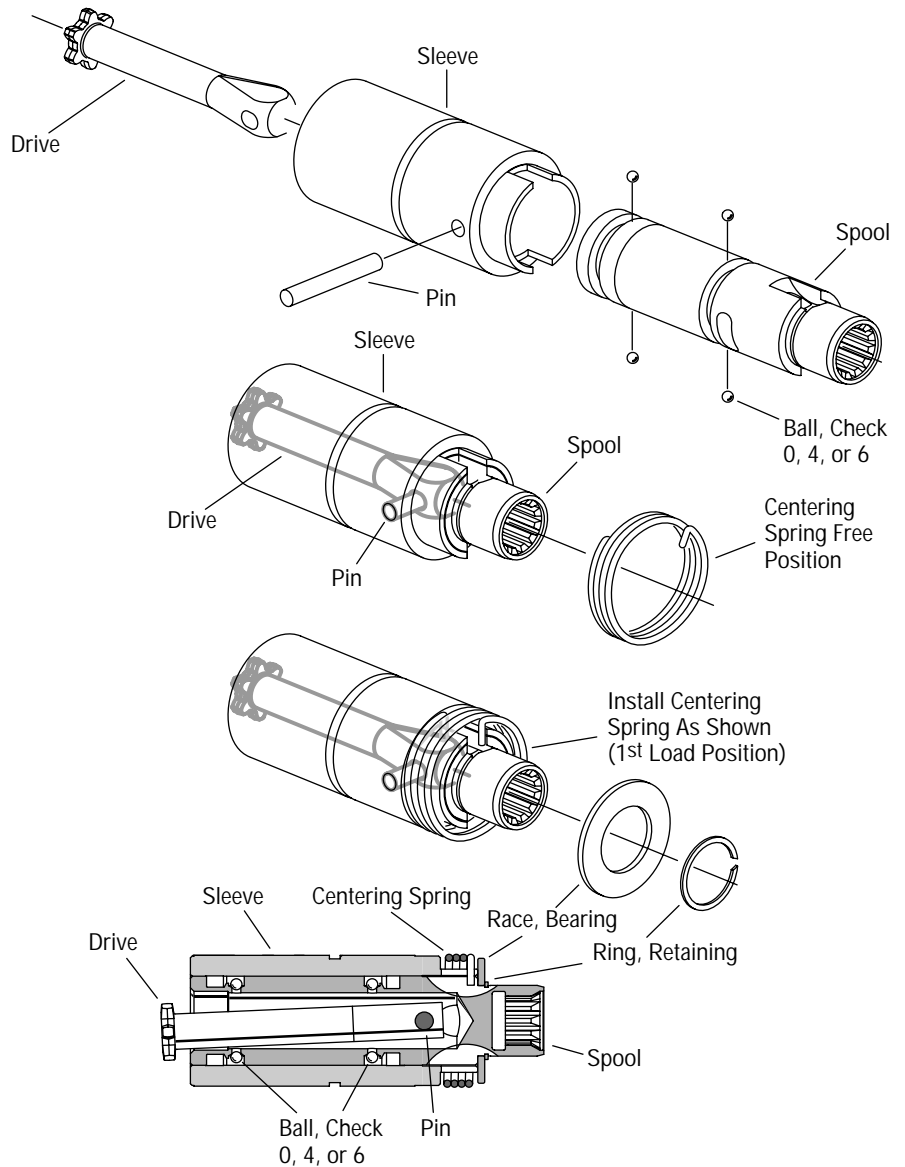

20 Series Steering Control Units

Reassembly

17 Apply a light coating of petroleum jelly to the inside diameter of the previously mounted dust seal in the housing.

18 Apply a light coating of petroleum jelly to the needle thrust bearing, second bearing race, and three part shaft seal. Position each part onto the spool as shown in enlarged section drawing below. The needle thrust bearing goes between the two bearing races and must be centered around retaining ring.

19 Apply a light coating of clean hydraulic fluid to the spool and sleeve assembly and slide it into the housing (see steps 20-25).

Important: Do not damage the dust or shaft seals.

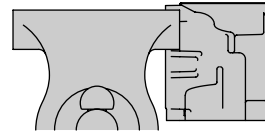

Housing Vertically Mounted

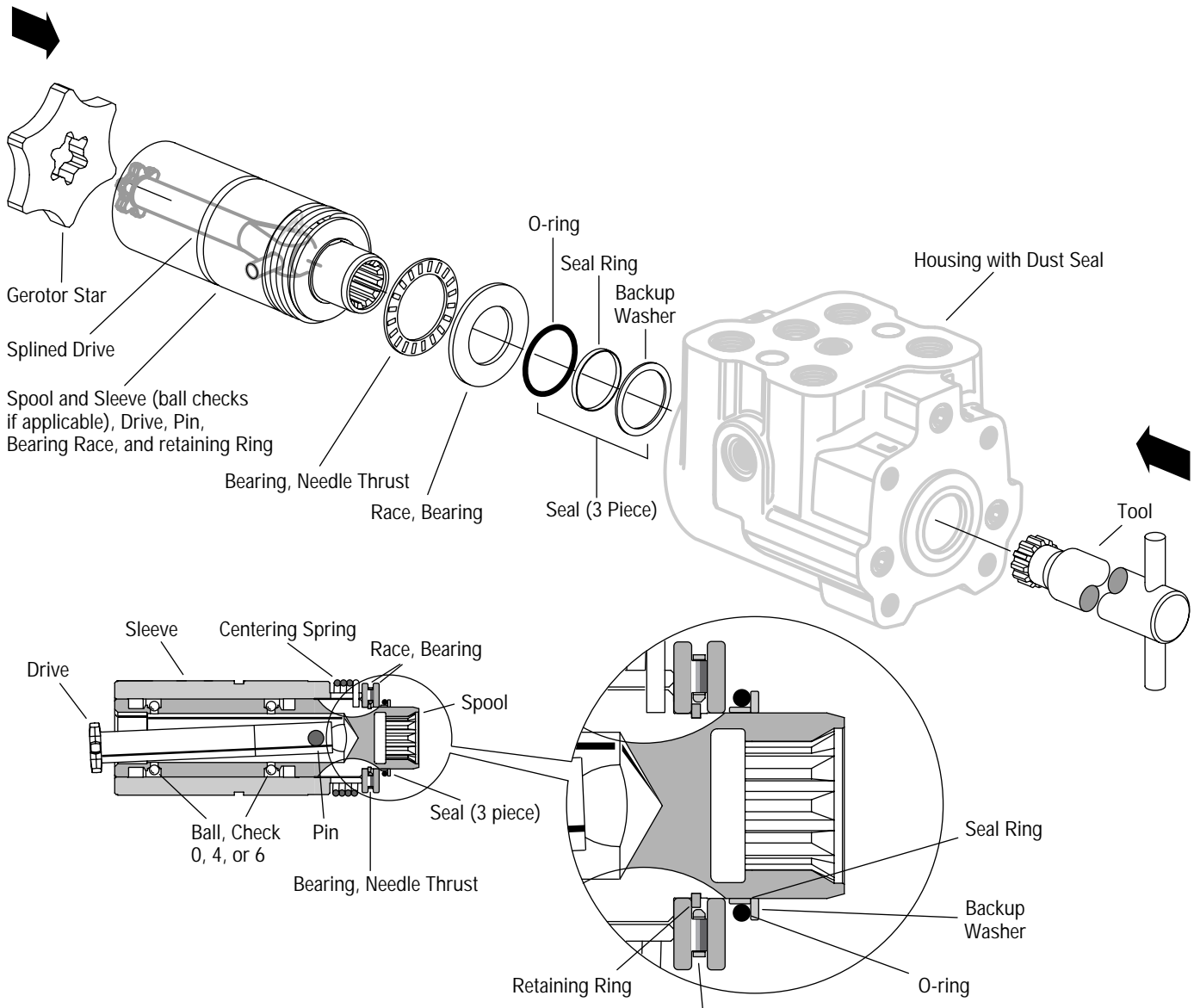

Note: Needle Thrust Bearing MUST Be Centered Around Retaining Ring. Use Petroleum Jelly to Hold Parts in Place.

20 Series Steering Control Units

Reassembly

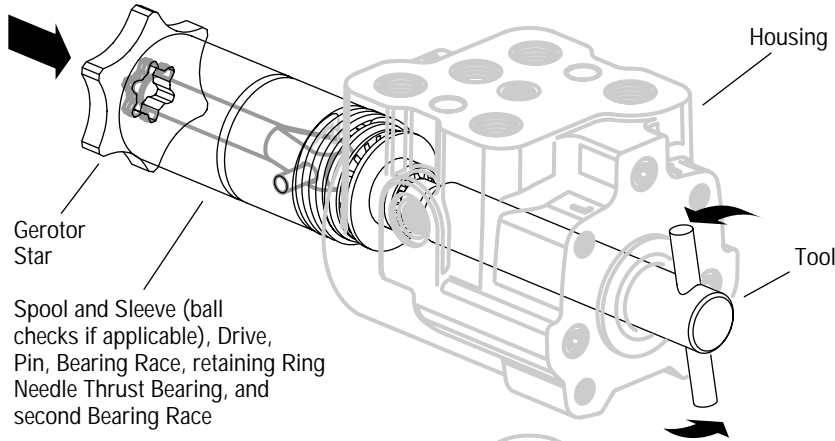

20 Protect gerotor star and hand with shop towel — hold gerotor star and splined end of drive to keep it from turning.

21 Insert tool through housing; engage with splined end of spool assembled inside of sleeve along with ball checks (if applicable), centering spring, drive, pin, bearing race, retaining ring, needle thrust bearing, second bearing race, shaft seals and backup washer. Twist tool to compress spring coils radially CW or CCW.

Note: If by some chance this unit is in the horizontal position keep pin nearly horizontal. If tension on this pin is released before these parts are fully engaged and the pin is not horizontal, the pin can drop and lockup can occur like a deadbolt.

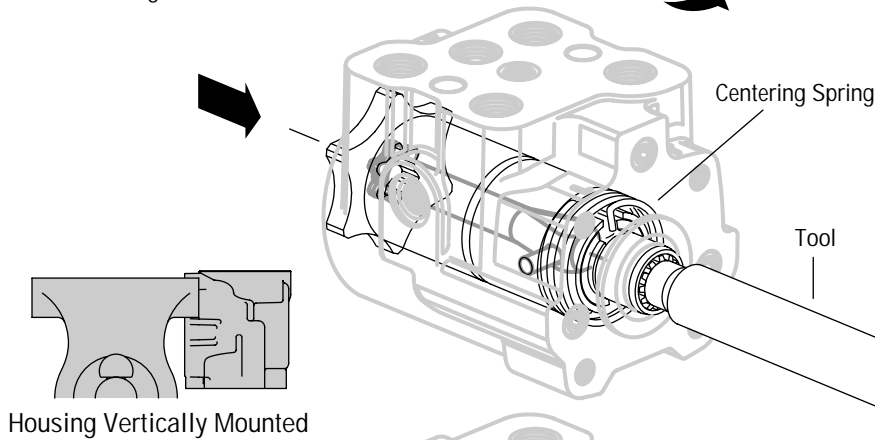

22 Keep centering spring compressed, and carefully insert these assembled parts into housing. DO NOT FORCE. (Bearing races, retaining ring, needle thrust bearing, shaft seals and backup washer not shown on drawing at left. Centering spring shown compressed.)

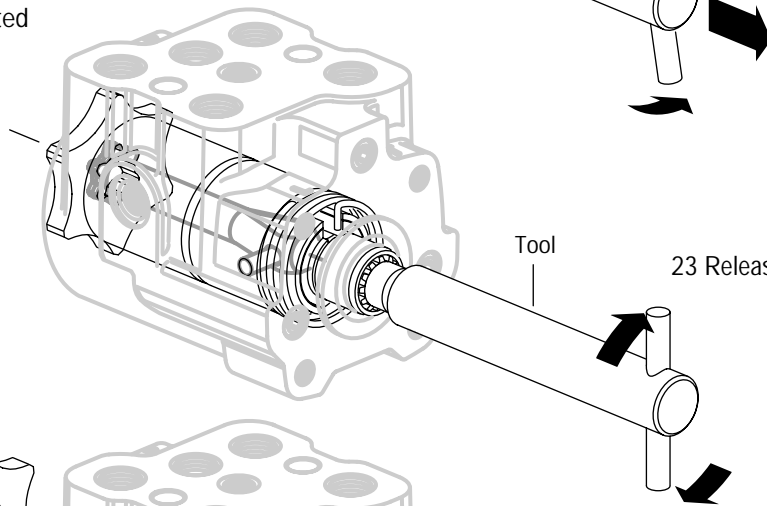

23 Release centering spring tension.

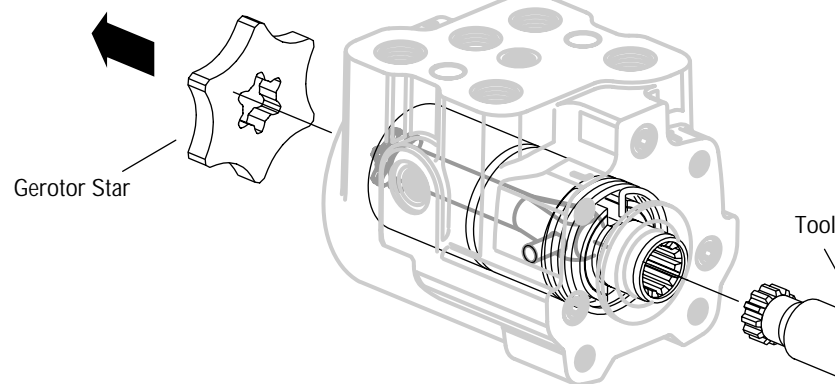

24 Remove gerotor star.

25 Remove tool.

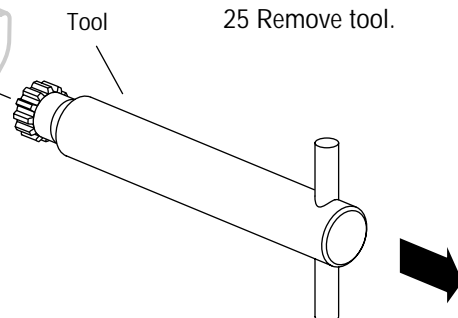

20 Series Steering Control Units Reassembly

25 Lubricate and install a new o-ring seal in the groove in the housing.

26 Install the wear plate o-ring groove up and align the holes in the wear plate with threaded holes in the housing.

27 Lubricate and install a new o-ring seal in the groove in the wear plate.

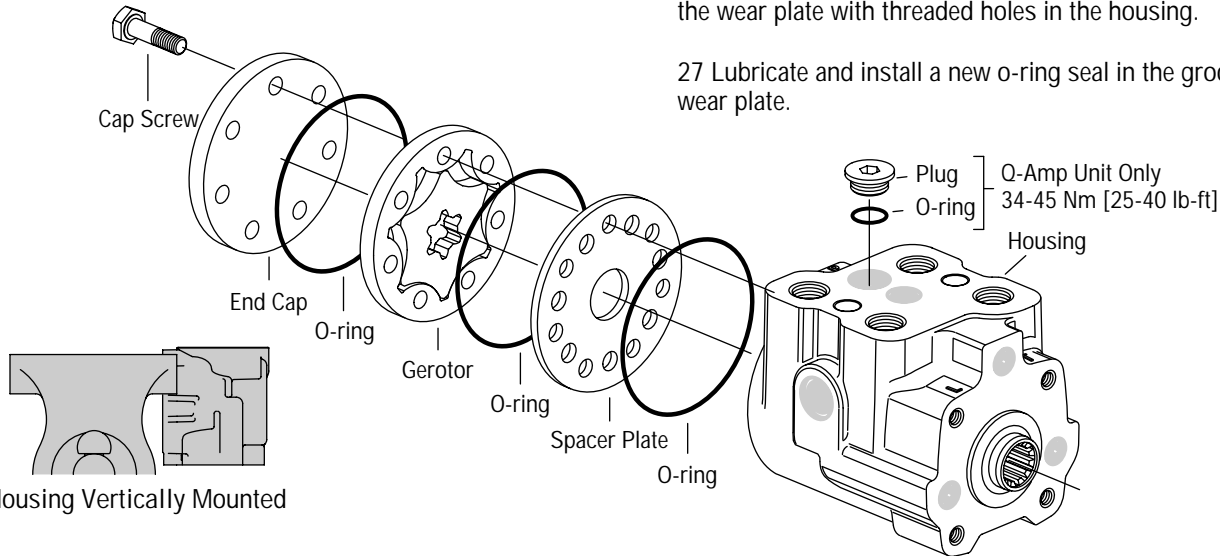

28 Install the gerotor and align the screw holes.

29 Lubricate and install a new o-ring seal in the groove in the gerotor ring.

30 Install the end cap and seven cap screws. Pretighten the cap screws, in a crisscross pattern, to 17 Nm [150 lb-in]. Finally, in a crisscross pattern, tighten cap screws to 33,9 Nm [300 lb-in].

How to Order Replacement Parts

Each Order Must Include the Following:

1. Product Number
2. Date Code
3. Part Name
4. Part Number
5. Quantity of Parts

For More Detailed Information Contact Eaton Corp. Hydraulics Division 15151 Highway 5 Eden Prairie, MN 55344.

- Specifications and performance data, Catalog No. 11-303
- Replacement part numbers and kit information — Parts Information No. 6-326

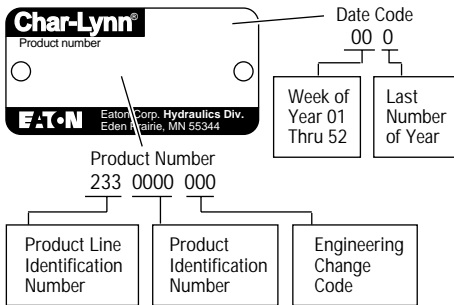

Eaton Corporation
Hydraulics Division
15151 Hwy. 5
Eden Prairie, MN 55344
Telephone 612/937-9800
Fax 612/937-7130

Eaton Ltd.
Hydraulics Division
Glenrothes, Fife
Scotland, KY7 4NW
Telephone 01-592-771-771
Fax 01-592-773-184

Eaton GmbH
Hydraulics Products
Am Schimmersfeld 7
40880 Ratingen, Germany
Telephone 02102-406-830
Fax 02102-406-800



Quality System Certified
Products in this catalog are manufactured
in an ISO-9001-certified site.