

Char-Lynn®
Hydraulic Motor

No. 7-132
October, 1997

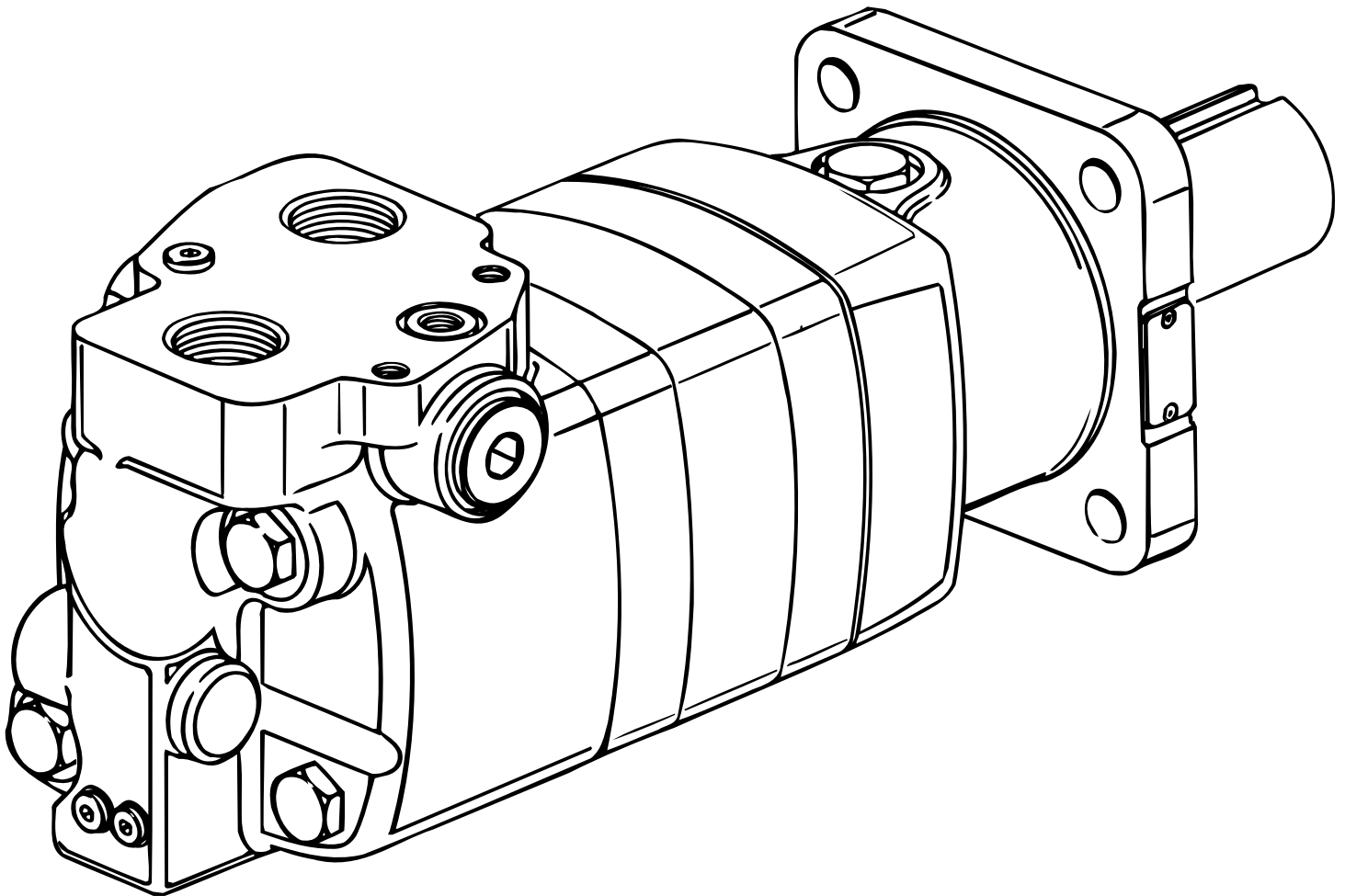

Repair Information



10 000 Series
Geroler® Motor—Two Speed

001

Parts Drawing

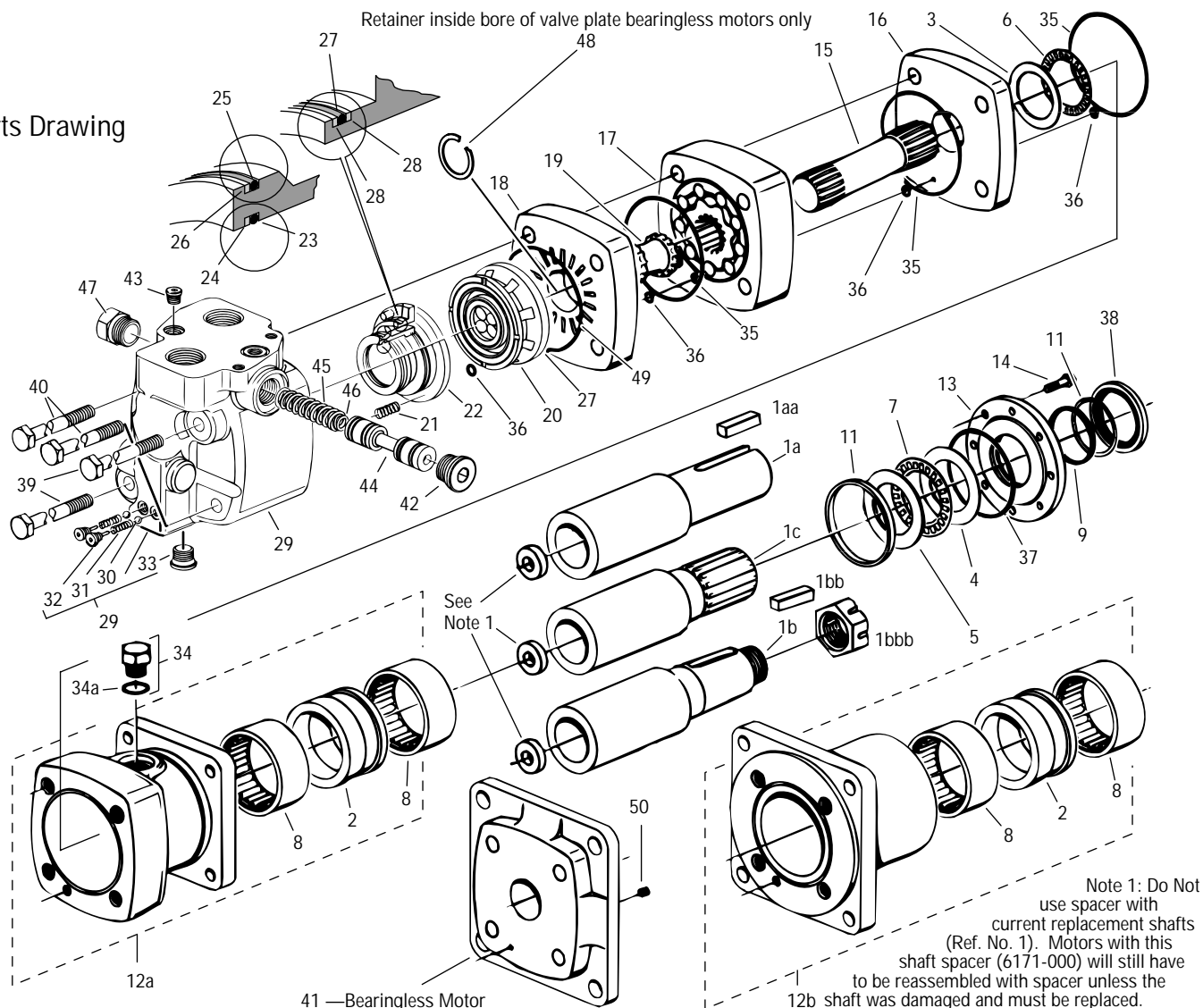

41 —Bearingless Motor

Ref. No.	Description
1a	Shaft S/A (2-1/4 in. Str. w/o Thread)
1aa	Key (Str. Shaft)
1b	Shaft S/A (2-1/4 in. Tapered)
1bb	Key (Tapered Shaft)
1bbb	Nut (Tapered Shaft)
1c	Shaft S/A (2-1/8 in. 16T Involute Spline)
2	Spacer, Bearing
3	Thrust Washer, Rear
4	Whasher, Thrust
5	Whasher, Thrust
6	Thrust Bearing, Rear
7	Thrust Bearing, Front
8	Bearing, Radial
9	Seal, Shaft
10	Washer, Backup
11	Spacer, Front Bearing
12a	Housing, Bearing (Std. Mtr. Mtg. Flange)
12b	Housing, Bearing (Whl. Mtr. Mtg. Flange)
13	Retainer, Front
14	Screw, Cap
15	Drive

Ref. No.	Description
16	Plate, Wear
17	Geroler
18	Plate, Valve
19	Drive, Valve
20	Valve
21	Spring
22	Balance Ring/Pin Assembly
23	O-ring
24	Ring, Back-up
25	O-ring
26	Ring, Back-up
27	O-ring
28	Ring, Back-up
29	Valve Housing
30	Ball
31	Spring
32	Plug/O-ring S/A
32a	O-ring (Ref. No. 32)
33	Plug/O-ring S/A
33a	O-ring (Ref. No. 33)
34	Plug/O-ring S/A

Ref. No.	Description
34a	O-ring (Ref. No. 34)
35	Seal
36	Seal
37	O-ring
38	Seal, Dust
39	Bolt (replaces and interchanges with studs)
40	Bolt (replaces and interchanges with studs)
41	Flange, Mounting /Wear Plate
42	Plug/O-ring S/A
42a	O-ring (Ref. No. 42)
43	Plug/O-ring S/A
43a	O-ring (Ref. No. 43)
44	Spool, Control
45	Spring, Compression
46	Spring, Compression
47	Plug/O-ring S/A
47a	O-ring (Ref. No. 47)
48	Ring, Retaining
49	O-ring
50	Plug, Pipe

10 000 Series Geroler Motors—Two Speed

Tools Required:

- Torque Wrench, 165 Nm [120 lb-ft] * capacity
- 15/16, 1, and 1-1/4 inch sockets
- 5/32, 3/16, 5/16, and 5/8 inch hex keys
- 300 mm to 450 mm [12 to 16 inch] breaker bar
- Small blade screwdriver, 150 to 200 mm [6 to 8 inch] long
- Plastic or rubber hammer

Special Tools:

- Small internal bearing puller, sliding hammer type
- Output shaft sleeve

* Inch equivalents given in [brackets].

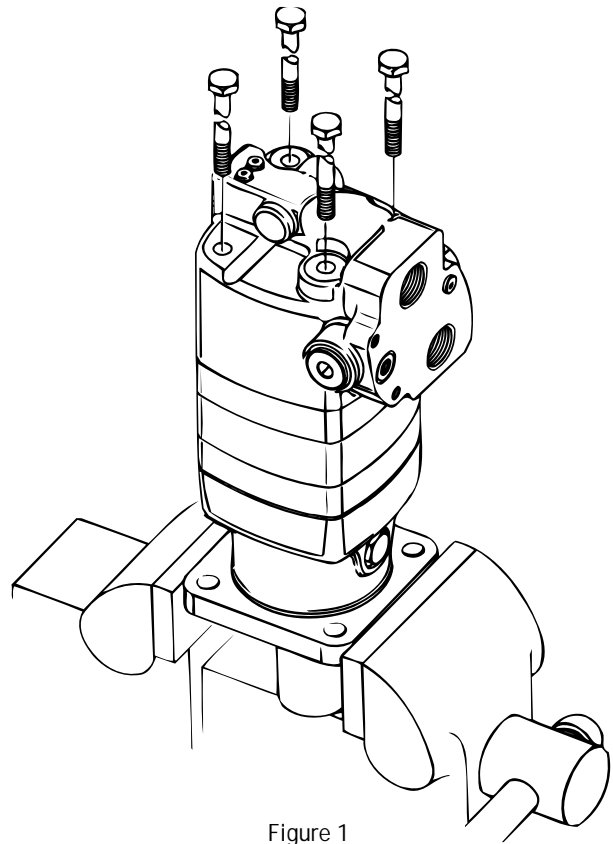

Figure 1

Disassembly

Cleanliness is extremely important when repairing hydraulic motors. Work in a clean area. Before disconnecting the oil lines thoroughly clean the port area of the motor. After the oil lines have been disconnected, plug the motor's ports to prevent dirt from entering. Clean the exterior of the motor with a wire brush. Check the keyway and chamfered area of the output shaft and remove any nicks, burrs, or sharp edges that could damage the shaft seals during reassembly. Drain the oil from the motor before beginning disassembly.

Note: On the standard and wheel motors the output shaft seal and dust seal can be changed without completely disassembling the motor. Steps 23 through 41 describe shaft and dust seal replacement. If complete disassembly is planned, both the shaft seal kit and motor seal kit will be needed. Refer to parts list 6-131 for seal kit part numbers.

1 Place the motor in a vise with the output shaft down. Clamp on the motor's mounting flange as shown in Figure 1. Protect the mounting flange with soft vise jaws, wood, or hard rubber. Use just enough clamping force to hold the motor securely during repairs. Excessive force will distort the motor housing.

Note: Even though the motor is not shown in a vise in all the drawings, it is recommended that the motor be kept clamped in a vise during repairs.

2 Remove the four hex head bolts from the motor.

10 000 Series Geroler Motors—Two Speed

Disassembly

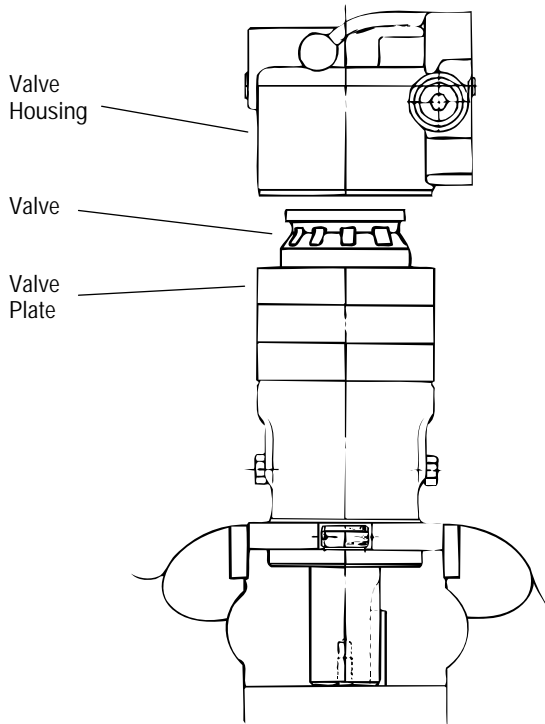

Figure 2

3 Carefully lift the valve housing straight up. The balance ring should lift away with the valve housing. The valve will remain on the valve plate.

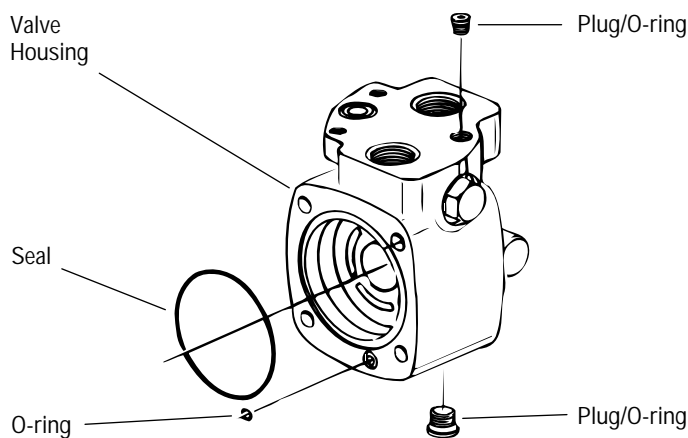

Figure 3

4 Set the valve housing on a clean work bench. Be sure to protect its machined surfaces. Remove the 108 mm [4.25 in.] seal and 9,5 mm [.375 in.] o-ring.

5 Remove the plug and o-ring from the port face. Remove the case drain plug and o-ring from the bottom of the valve housing (see Figure 3).

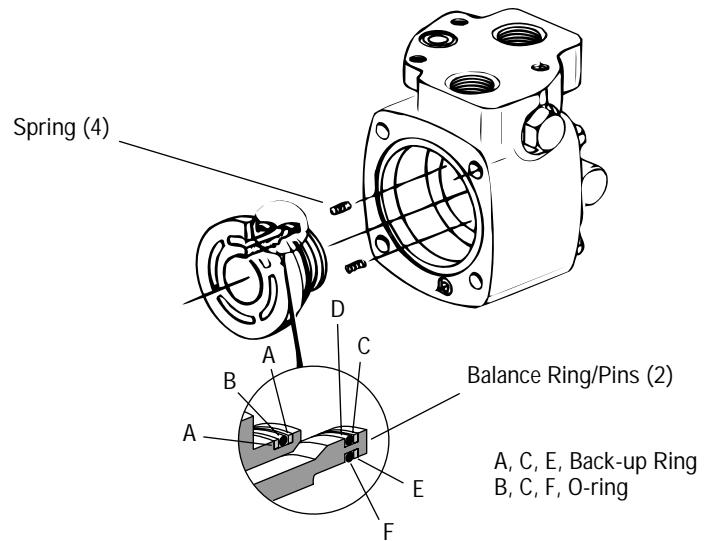

Figure 4

6 Remove the balance ring and four balance ring springs. The balance ring fits into the valve housing tightly. A sliding hammer bearing puller may be needed to loosen it.

7 Remove the o-rings and back-up rings from the balance ring.

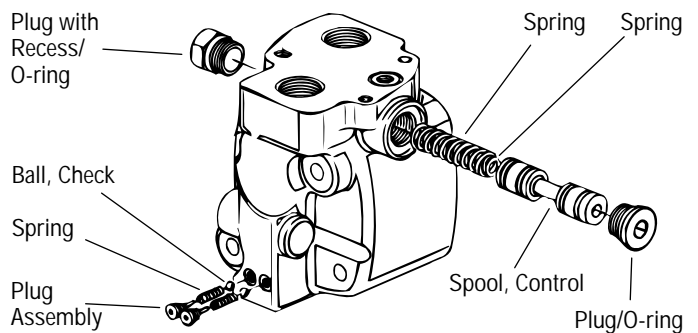

Figure 5

Note: Compressed springs under plugs, see step 8.

8 Carefully remove the two control spool plugs and o-rings.

9 Remove the control spool and springs.

10 Remove the two check ball plugs and o-rings. Remove the two check balls and springs.

10 000 Series Geroler Motors—Two Speed

Disassembly

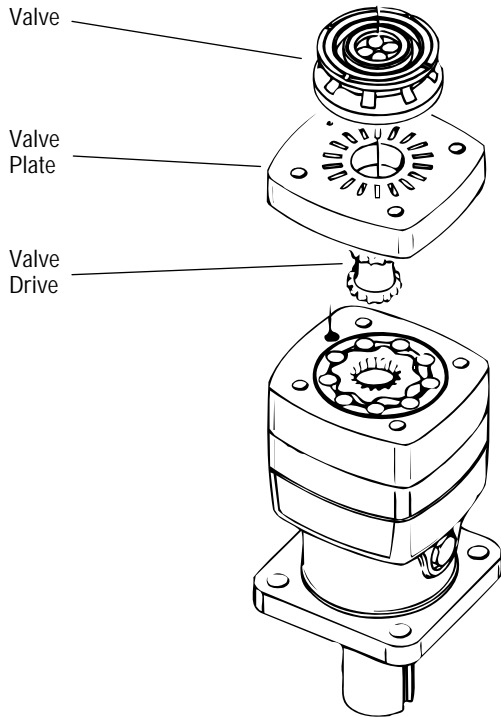

Figure 6

- 11 Remove the valve.
- 12 Remove the valve plate.
- 13 Remove the valve drive.

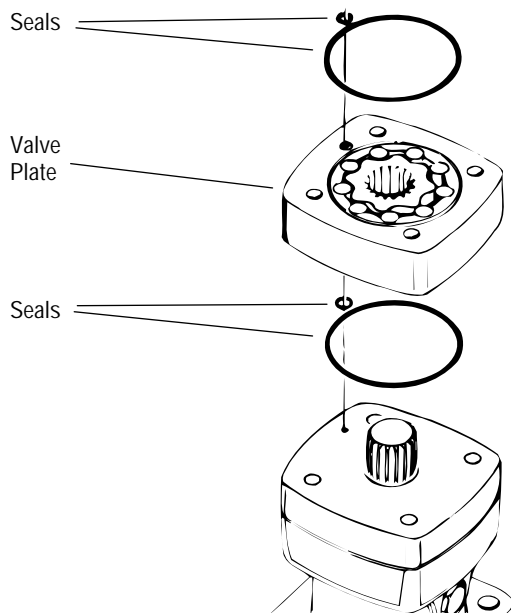

Figure 7

- 14 Remove the Geroler. Be sure to keep the Geroler star and rollers within the outer ring if they are loose.

- 15 Remove the 108 mm [4.25 in.] seal and 9,5 mm [.375 in.] o-ring from each side of the Geroler.

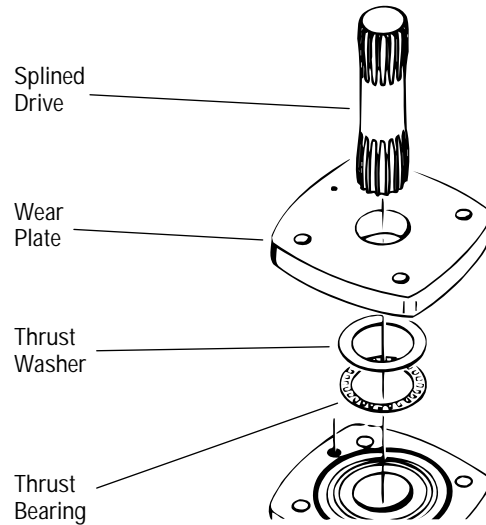

Figure 8

- 16 Remove the splined drive.

- 17 Remove the wear plate.

- 18 Remove the rear thrust bearing and rear thrust washer. These parts will either be on the wear plate or shaft bearings.

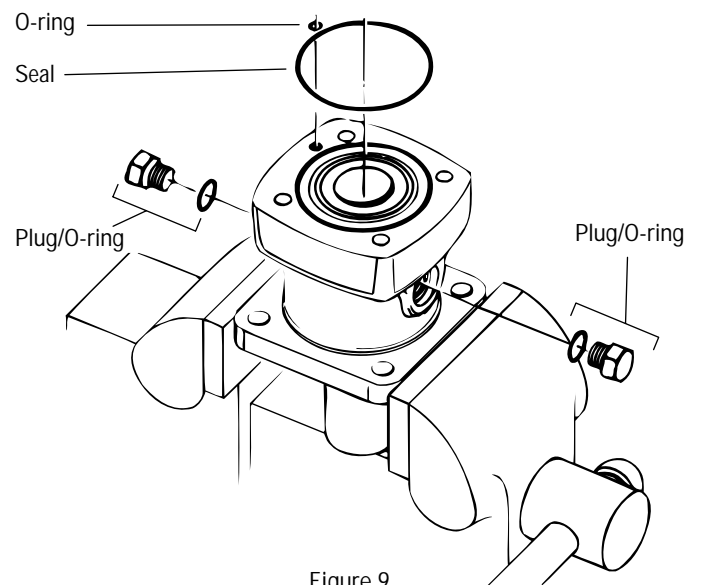

Figure 9

10 000 Series Geroler Motors—Two Speed

Disassembly

19 Remove the 108 mm [4.25 in.] seal and 9,5 mm [.375 in.] o-ring from the bearing housing.

20 Remove the two case drain plugs and o-rings from the bearing housing.

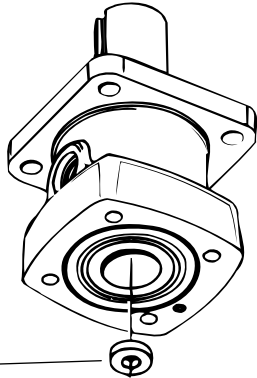

Figure 10

21 Remove the bearing housing from the vise and turn it over so the output shaft is on top.

22 The drive spacer may fall out of the output shaft (see Figure 10). Watch for it! This spacer must be reinstalled when the motor is reassembled.

Note: Some motors do not use a drive spacer.

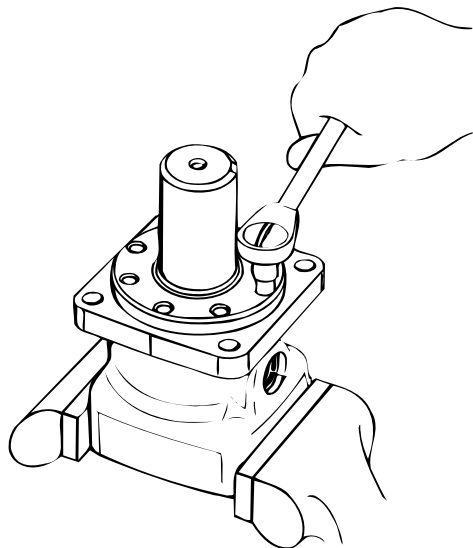

Figure 11

23 Clamp the bearing housing in a vise so the output shaft is on top (see Figure 11). Protect the bearing housing with soft vise jaws, wood, or hard rubber. Use just enough clamping force to hold the bearing housing securely while the retainer is removed.

24 Remove the eight cap screws that hold the retainer to the bearing housing.

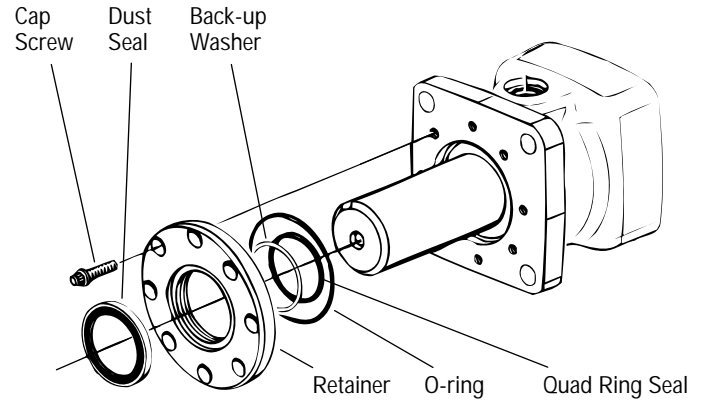

Figure 12

25 Carefully pry the retainer loose with a small blade screwdriver. Do not damage the mating surfaces of the retainer or bearing housing.

26 Remove the 89 mm [3.5 in.] o-ring from the retainer.

27 Use a small blade screwdriver to pry the quad ring seal and back-up washer from the retainer. Be careful not to damage the seal seat.

28 Turn the retainer over and pry out the dust seal with a small blade screwdriver. Be careful not to damage the seal seat (see Figure 12).

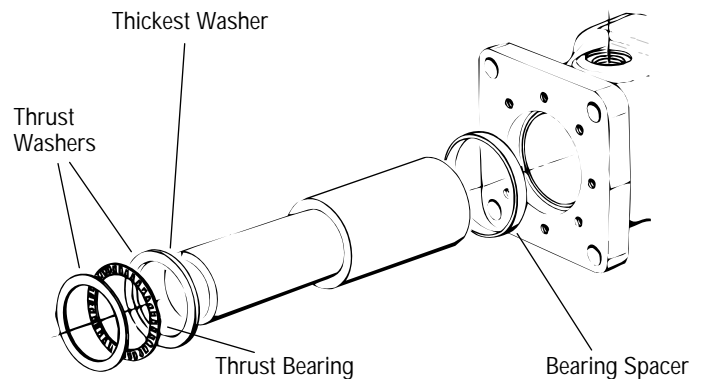

Figure 13

29 Remove the output shaft.

30 Remove the thrust bearing and two thrust washers from the output shaft.

31 Remove the bearing spacer.

Note: The shaft bearings are pressed into the bearing housing and should not be removed. If the housing or bearings are damaged the complete assembly must be replaced.

10 000 Series Geroler Motors—Two Speed

Reassembly

Check all mating surfaces and replace any parts with scratches or burrs that could cause leakage. Wash all metal parts in clean solvent and blow them dry with compressed air. Do not wipe parts dry with paper towels or cloth as lint in a hydraulic system will cause damage. Check the keyway and chamfered area of the output shaft and remove any nicks, burrs, or sharp edges that could damage the shaft seals during reassembly.

Note: Always use new seals when reassembling hydraulic motors. Refer to parts list 6-131 for seal kit part numbers, replacement parts, and ordering information.

Important: During reassembly lubricate the new seals with a petroleum jelly such as Vaseline®. Also lubricate all machined surfaces and bearings with clean hydraulic fluid.

32 Re-clamp the bearing housing in a vise with the mounting flange up (see Figure 11). Remember, use just enough clamping force to hold the bearing housing securely while the output shaft and retainer are reinstalled.

33 Install the bearing spacer.

34 Lubricate the output shaft with clean hydraulic fluid and insert it into the bearing housing. Rotate it as it is inserted.

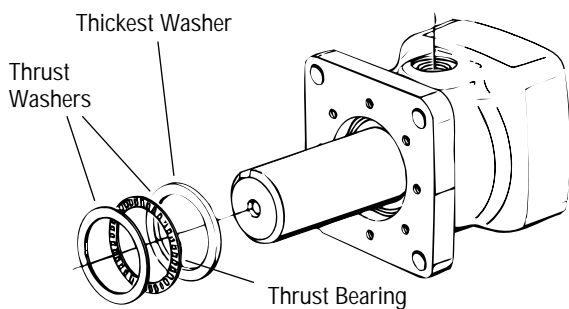

Figure 14

35 Install the thrust bearing and thrust washers. Install the thick thrust washer first, then the thrust bearing, then the thin thrust washer.

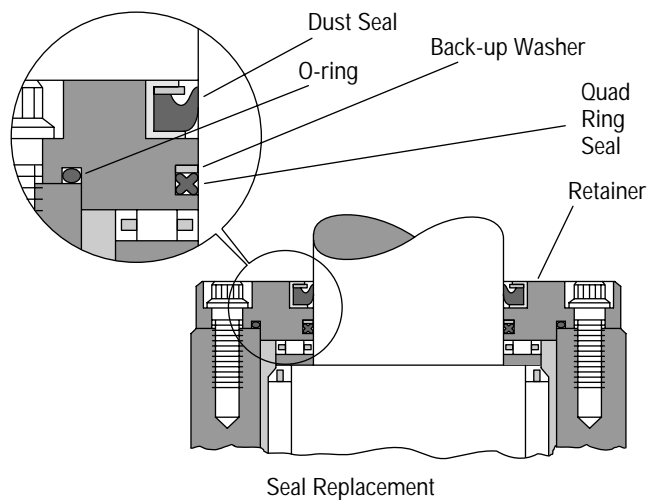

Figure 15

36 Press the dust seal into the retainer. The metal side of the dust seal must face the retainer (see Figure 15). If a press is not available carefully tap the dust seal into the retainer with a plastic or rubber hammer.

37 Install the quad ring seal and back-up washer as shown in Figure 15.

38 Apply petroleum jelly to the 89 mm [3.50 in.] O-ring and install it in the groove in the retainer.

39 Lubricate the inner edge of the dust seal and quad ring seal with petroleum jelly.

40 Slide the retainer over the output shaft onto the bearing housing. **Important:** Do not damage the seals. Use an output shaft sleeve to protect the seals if available.

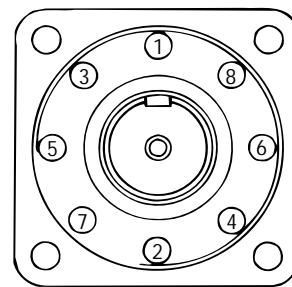

Torquing Sequence

Figure 16

41 Install the eight cap screws and tighten them to 34 Nm [300 lb-in]. Follow the screw torque sequence in Figure 16.

10 000 Series Geroler Motors—Two Speed Reassembly

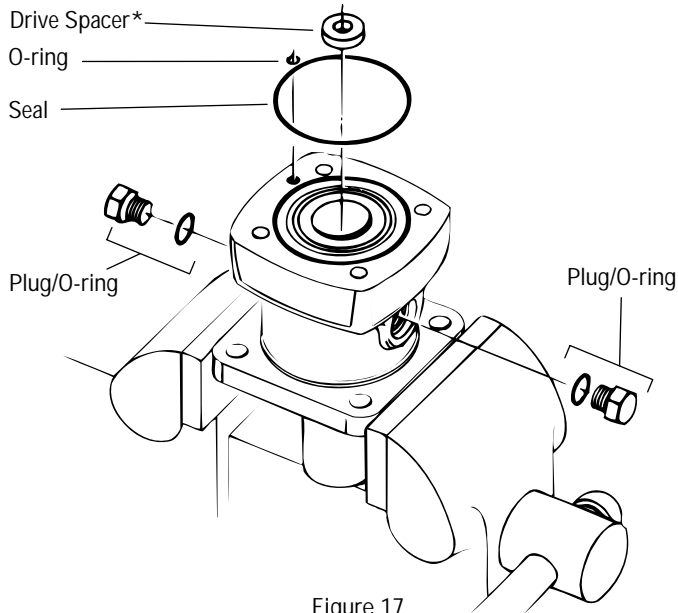

Figure 17

42 Reposition the bearing housing in the vise so the output shaft is in the down position.

43 Install the two case drain plugs in the bearing housing drain holes. Use new o-rings and tighten the plugs to 81-122 Nm [60-90 lb-ft].

44 Pour a small amount of clean hydraulic fluid into the bearing housing and output shaft.

45 Reinstall the drive spacer* if it was dislodged during disassembly. Use a long thin rod to guide the drive spacer into the output shaft.

*Note: Do not use spacer with current motors or replacement shafts. Motors with this shaft spacer will still have to be reassembled with this spacer unless the shaft was damaged and must be replaced.

46 Apply petroleum jelly to the 108 mm [4.25 in.] seal and 9,5 mm [.375 in.] o-ring. Install each in the appropriate groove in the bearing housing (see Figure 17).

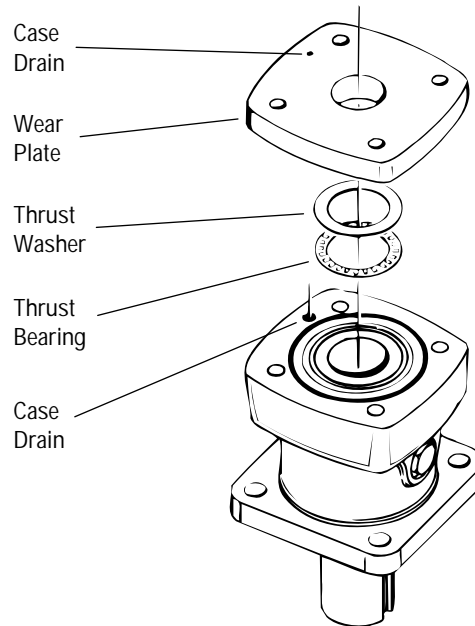

Figure 18

47 Put the rear thrust washer and rear thrust bearing into the recess in the wear plate. The rear thrust washer goes in first. Petroleum jelly may be used to hold these parts in place while the wear plate is being installed.

48 Install the wear plate so the rear thrust washer is against the shaft bearings. Be sure to align the case drain holes.

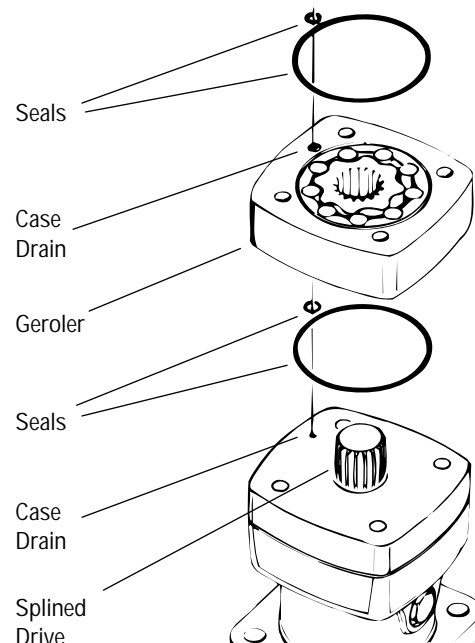

Figure 19

10 000 Series Geroler Motors—Two Speed Reassembly

49 Install the splined drive.

Note: On smaller displacement motors the splined ends of the drive are different lengths. If this is the case the longer spines go into the bearing housing.

50 Determine which side of the Geroler goes against the wear plate. Install the 108 mm [4.25 in.] seal and 9,5 mm [.375 in.] o-ring in the appropriate grooves in that side of the Geroler. Apply petroleum jelly to the seal and o-ring before installation.

51 Install the Geroler on the wear plate. Be sure to align the case drain holes.

52 Apply petroleum jelly to the 108 mm [4.25 in.] seal and 9,5 mm [.375 in.] o-ring. Install each in the appropriate groove in the top side of the Geroler.

53 Install the valve drive.

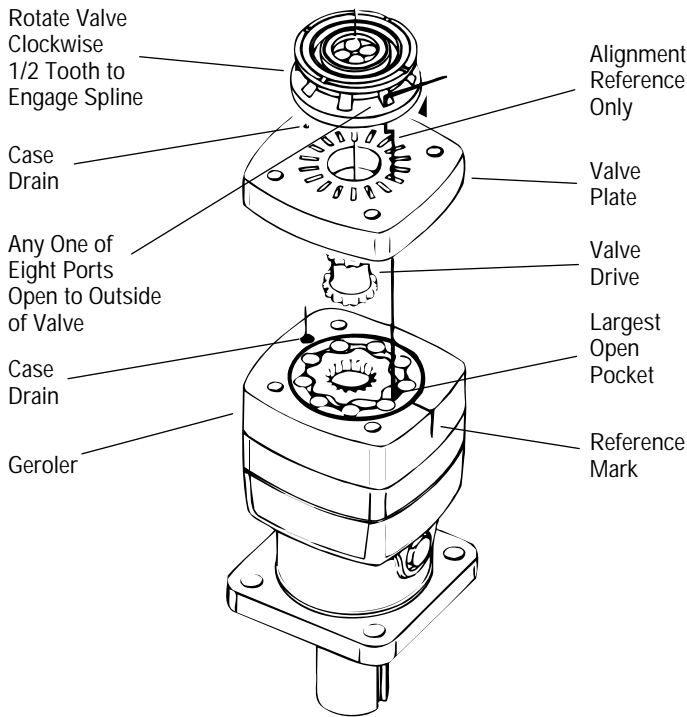

Figure 20

Motor Timing Timing a hydraulic motor involves three steps. The direction the output shaft rotates is determined by timing.

Timing Step #1 Locate the largest open pocket in the Geroler and mark its position.

54 Install the valve plate on the Geroler. Be sure to align the case drain holes.

Timing Step #2 Locate the open slot in the valve plate that is in line with the largest open pocket in the Geroler.

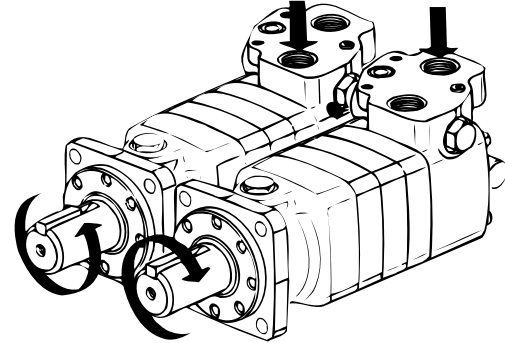

Standard Timing

Figure 21

Timing Step #3 Align any one of the side openings in the valve with the open slot in the valve plate that is over the largest open pocket in the Geroler. Engage the valve with the valve drive by rotating it clockwise until the spine teeth mesh (1/2 spline tooth). This will provide standard rotation when pressurized (see Figure 21).

To reverse rotation engage the valve with the valve drive by rotating it counter clockwise until the spline teeth mesh (1/2 spine tooth).

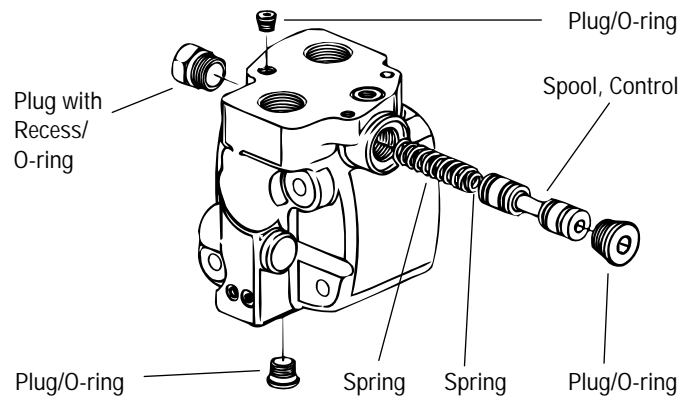

Figure 22

55 Install the control spool and springs.

56 Install the control spool plugs with new o-rings. The springs will need to be compressed to install the second plug.

57 Tighten the control spool plugs to 81 -122 Nm [60-90 lb-ft].

58 Install the plug in the port face. Use a new o-ring and tighten the plug to 27-46 Nm [20-34 lb-ft] (see Figure 22).

10 000 Series Geroler Motors—Two Speed

Reassembly

59 Install the case drain plug in the bottom of the valve housing. Use a new o-ring and tighten the plug to 81-122 Nm [60-90 lb-ft] (see Figure 22).

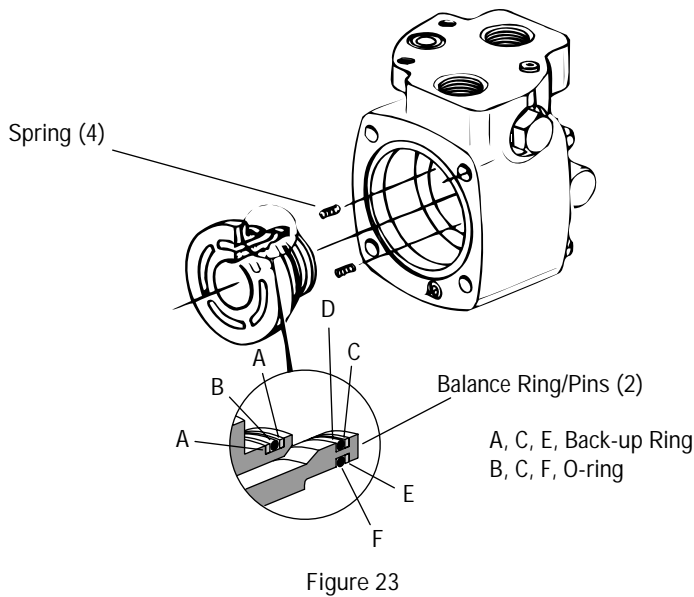

60 Install the o-rings and back-up rings on the balance ring. Install the o-rings first then the back-up rings.

61 The largest o-ring has two back-up rings, one on each side. The two smaller o-rings each have one back-up ring. The two smaller back-up rings are installed closest to the small end of the balance ring.

62 Put the four balance ring springs into their holes in the valve housing.

63 To aid the installation of the balance ring lubricate its o-rings and back-up rings with petroleum jelly. Align the balance ring index pins with the index holes in the valve housing. Push the balance ring into the valve housing until it just touches the springs.

Important: Do not push the balance ring all the way down into the valve housing.

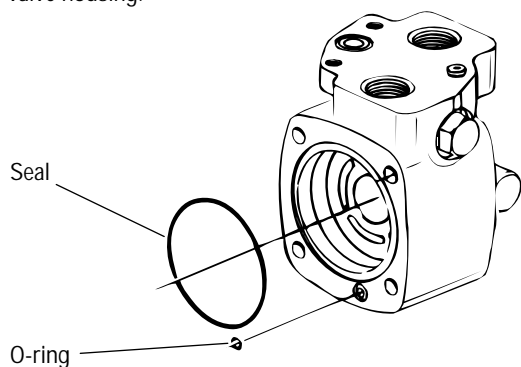

64 Apply petroleum jelly to the 108mm [4.25 in.] seal and 9.5 mm [.375 in.] o-ring. Install each in the appropriate groove in the valve housing.

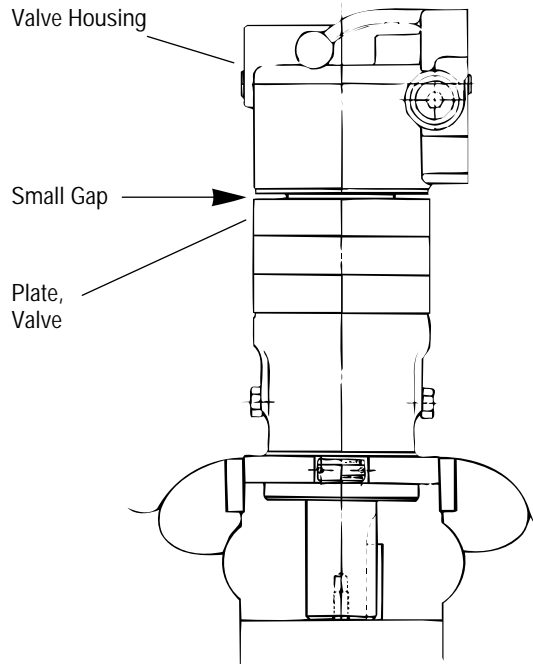

65 Carefully position the valve housing on the valve plate. Be sure to align the case drain holes. There should be a small gap between the valve housing and valve plate. This gap will be closed when the hex head bolts are tightened.

66 Install the four hex head bolts and tighten them to 129-149 Nm [95-110 lb-ft]. Follow the torque sequence in Figure 26.

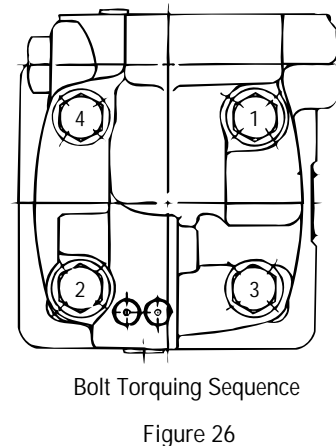

67 Install the two check balls and springs.

10 000 Series Geroler Motors—Two Speed

Reassembly

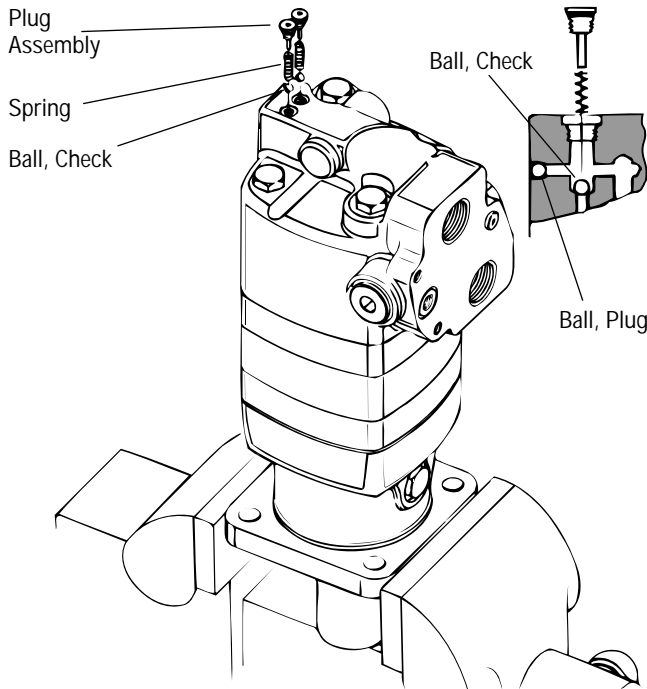

Figure 27

Important: The motor shaft must be vertical when the check balls are installed. This will insure that they seat properly (see Figure 27).

68 Install the two check ball plugs with new o-rings and tighten them to 6.8-12 Nm [5-10 lb-ft].

Wheel Motor

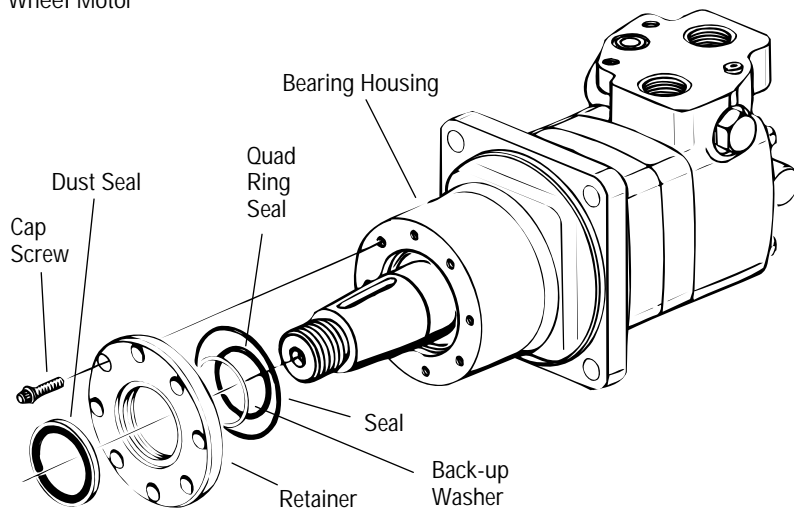

Figure 28

A different bearing housing is used on wheel motors (see Figure 28). Other than this the parts are the same and the same disassembly/reassembly procedures apply.

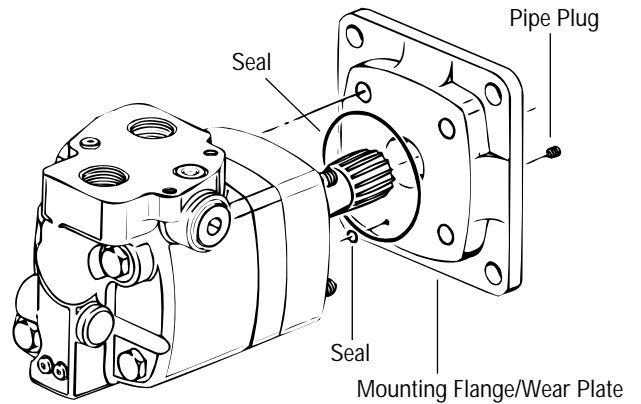

Figure 29

Bearingless Motor

Bearingless motors are the same as standard motors without the shaft/bearing assembly, and thrust bearings. The mounting flange replaces the bearing housing and wear plate (see Figure 29).

Disc Valve Hydraulic Motor

10 000 Series Geroler Motors—Two Speed

For Additional Literature Contact Eaton Corp. Hydraulics Division 15151 Highway 5 Eden Prairie, MN 55344.

- Specifications and performance Data, Catalog No. 11-878
- Replacement Part Numbers and Kit Information: 10 000 Series Motors —Two Speed Parts Information No. 6-131.

How to Order Replacement Parts

Each Order Must Include the Following:

- | | |
|-------------------|----------------------|
| 1. Product Number | 4. Part Number |
| 2. Date Code | 5. Quantity of Parts |
| 3. Part Name | |

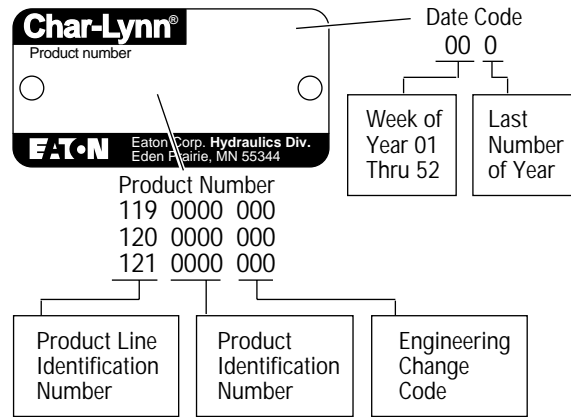

Mounting	Shaft	Ports	Displ. cm ³ /r [in ³ /r] Product Number				
			345 [21.0]	480 [29.3]	665 [40.6]	940 [57.4]	
Standard	2-1/4 inch Straight	1-5/16 O-ring	119-2013	-2014	-2015	-2016	
		1-1/4 Split Flange	119-2001	-2002	-2003	-2004	
	2-1/4 Inch Tapered	1-5/16 O-ring	119-2017	-2018	-2019	-2020	
		1-1/4 Split Flange	119-2005	-2006	-2007	-2008	
	2-1/8 Inch 16 T Splined	1-5/16 O-ring	119-2021	-2022	-2023	-2024	
		1-1/4 Split Flange	119-2009	-2010	-2011	-2012	
	Wheel Motor	2-1/4 inch Straight	1-1/4 Split Flange	120-2005	-2006	-2007	-2008
			1-5/16 O-ring	120-2013	-2014	-2015	-2016
2-1/4 Inch Tapered		1-1/4 Split Flange	120-2001	-2002	-2003	-2004	
		1-5/16 O-ring	120-2013	-2014	-2015	-2016	
2-1/8 Inch 16 T Splined	1-1/4 Split Flange	120-2009	-2010	-2011	-2012		
	1-5/16 O-ring	121-2005	-2006	-2007	-2008		
Bearingless		1-1/4 Split Flange	121-2001	-2002	-2003	-2004	

Eaton Corporation
Hydraulics Division
15151 Hwy. 5
Eden Prairie, MN 55344
Telephone 612/937-9800
Fax 612/937-7130

Eaton Ltd.
Hydraulics Division
Glenrothes, Fife
Scotland, KY7 4NW
Telephone 01-592-771-771
Fax 01-592-773-184

Eaton GmbH
Hydraulics Products
Am Schimmersfeld 7
40880 Ratingen, Germany
Telephone 02102-406-830
Fax 02102-406-800



Quality System Certified
Products in this catalog are manufactured
in an ISO-9001-certified site.