

Installation Information

No. 4-427
October, 1999



Heavy Duty Series Eaton® Pump Controls 990821-000 and 990822-000 Swashplate Feedback Sensor Kit

Eaton Corporation
Hydraulics Division
15151 Hwy. 5
Eden Prairie, MN 55344
Telephone 612/937-7254
Fax 612/937-7130

Eaton Ltd.
Hydraulics Division
Glenrothes, Fife
Scotland, KY7 4NW
Telephone +44(0)1592-771-771
Fax +44(0)1592-773-184

Copyright Eaton Corporation, 1999
All Rights Reserved
Printed in USA

990821-000 – Feedback Sensor Kit (3-pin weatherpack shroud connector)

Part No.	Qty.	Description
113334-001	1	Feedback Sensor, Non Contact
95890-150	2	Socket Head Cap Screw 8-32 UNC
92897-008	2	Washer
8761-116	1	O-Ring
101673-025	1	10-24 Socket Button Head Cap Screw
113795-000	1	9/64" Hex Key

990822-000 – Feedback Sensor Kit (3-pin weatherpack tower connector)

Part No.	Qty.	Description
113334-002	1	Feedback Sensor, Non Contact
95890-150	2	Socket Head Cap Screw 8-32 UNC
92897-008	2	Washer
8761-116	1	O-Ring
113795-000	1	9/64" Hex Key

Equipment Required

1. Eaton Potentiometer Kit P/N 990821-000 or Kit P/N 990822-000
2. DC Power Supply capable of providing a constant, steady voltage anywhere between 5 and 15 Vdc. One 12V vehicle battery or a 9-volt battery will work if a power supply is not available.
3. Digital Multimeter capable of reading voltage to millivolt precision.
4. Two short jumper cables with banana jack terminations. (see Figure 1-1)
5. Short 3-wire cable; Delphi/Packard termination on one end, banana jack terminations on opposite end. (See Figure 1-2)
6. 9/64" and 1/4" Hex head wrenches.



CAUTION Make sure the battery is disconnected and the engine or motor providing power to pump is not running. Make sure the parking brake is engaged and other peripheral equipment is disengaged.

Step 1 – Using a 1/4 hex wrench remove the screw holding the clip to the Feedback Sensor connector as shown.



Step 2 – Using a 9/64 hex wrench remove the two screws holding the Feedback Sensor as shown.



Step 3 – Carefully remove the existing Feedback Sensor and gasket.

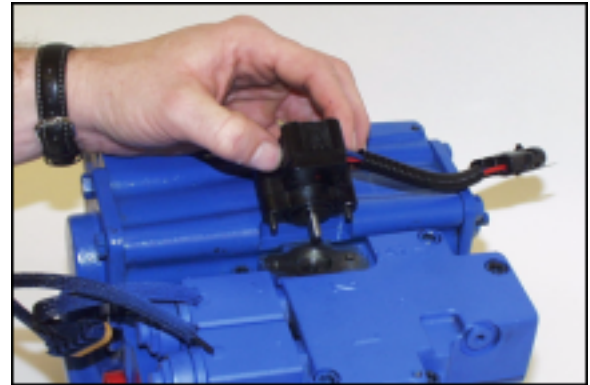

Step 4 – Install O-ring into groove on bottom of new feedback sensor.



Step 5

Install the new Feedback Sensor into place with the two cap screws and flat washers as shown. At this point only hand tighten the cap screws.



Step 7 – Set the Feedback Sensor Neutral

- a) Assuming the pump is destroyed and in neutral, connect the equipment as shown in Figure 1-2, below.

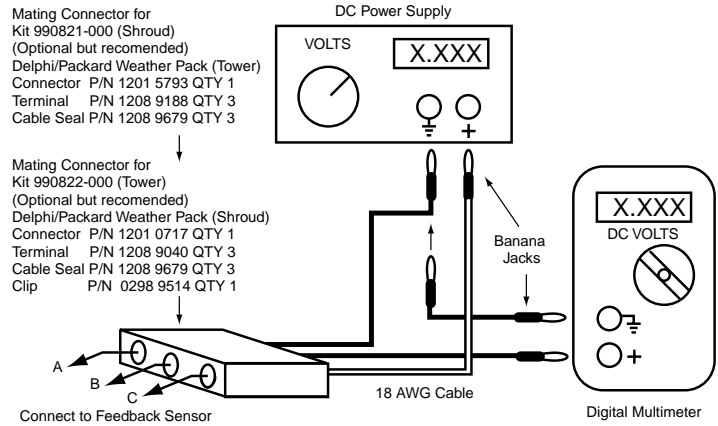

Figure 1-2

Step 6 – Set and Check the Supply Voltage

- a) Turn the power supply and multimeter on, and allow a brief warm-up period.
- b) Connect the equipment as shown in Figure 1-1, below.

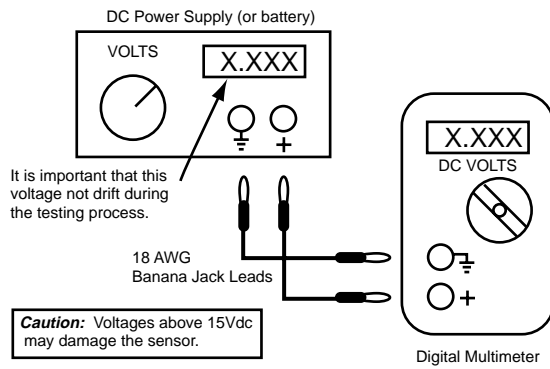

Figure 1-1

- b) Rotate the sensor housing counterclockwise until the multimeter indicates the sensor's output is exactly half the voltage recorded in step 6d ± X where:

$$X = \frac{\text{Voltage in step 6d}}{480}$$

- c) Torque the sensor screws to 26.2 ± 2.6 in-lb. (not ft-lb!) Due to the sensitivity of the sensor, the process of securing it may cause the sensor's output voltage to vary from the desired value.



Note: Precision on "X" in steps 7b & 7d is 3 digits after the decimal point.

- c) Set the multimeter to display DC Volts.
- d) Record the power supply output to the nearest millivolt.
- e) Do not make any change to the supply voltage from this point on.



- d) After the sensor is secured, verify that the sensor's output voltage displayed on the multimeter is still half the voltage recorded in step 6d ± X where:

$$X = \frac{\text{Voltage in step 6d}}{480}$$

This tolerance ensures that the sensor is centered to ± 0.1 degrees about the swashplate's neutral. IT IS VERY IMPORTANT THAT THE SENSOR OUTPUT BE WITHIN TOLERANCE!

- e) If the sensor output is out of tolerance, loosen the screws and repeat steps 7b through e.

Step 8 – Reattach the screw holding the clip and connector to the pump. The pump is now ready to return to operation.